

Input Capture with ST62 Auto-reload Timer

J.NICOLAI

INTRODUCTION

This note presents how to use the Auto-reload timer (ARTimer) of the ST62 to measure durations or frequencies of an input signal.

Auto-reload timer description

This timer is an 8 bit timer/counter with prescaler. It includes auto-reload PWM, capture and compare capability with one input and one output pins. It can be controlled by the following registers (8 bit):

- Mode Control Register (MC)
- Status registers (SC0, SC1)
- Load register (LR)
- Incremental counter register (TC)
- Compare register (CP)
- Reload/Capture register (RC)

It can also wake-up the MCU from wait mode and exit from stop mode if an external event is present on the input pin. The prescaler ratio can be programmed to choose the timer input frequency F_{IN} (see Table 1).

Figure 1. Auto-reload Timer Block Diagram

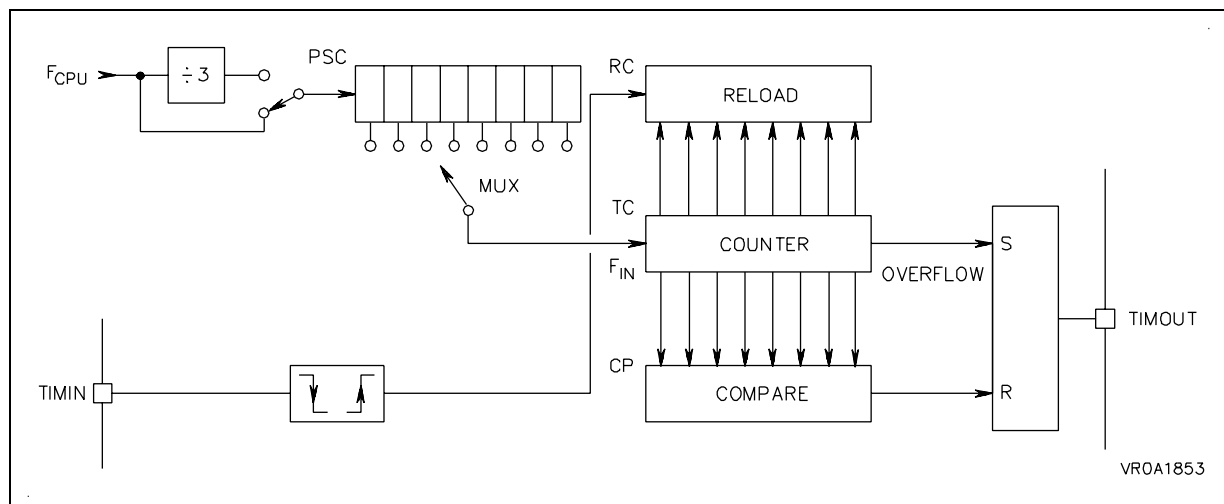

Capture Mode With Reset

This can be used to measure time durations or frequencies. This mode is used to measure the time elapsed between two edges of an external signal: two rising edges, two falling edges, or one rising and one falling if the configuration of the timer is modified after the first edge detected.

The minimum duration of one signal to measure depends on the CPU clock and on the required precision. With a 8MHz Quartz crystal, a signal of 8µs duration can be measured with a resolution of 1/64.

Example:

Let's measure the time elapsed between two rising edges on TIMIN:

The prescaler ratio must be programmed according to the expected duration to measure. In this example it is programmed to: prescaler ratio = 4, clock source = CPU clock. (in case the duration expected can be longer than the 255 count span of the TC count register, the overflow interrupt can be used to increment a RAM variable, used as the most significant part of the result).

In the program example, waiting for the edge on TIMIN is made by a software loop (jrr 2, SC0, wt_edge), but it is also possible to use the external event interrupt to read the result immediately after the edge without loading the rest of the program. It is also possible to read the result directly from RC without waiting or using the interrupt, if the duration is required at an asynchronous time, not just after the edge.

Table 1. Prescaler Programming Ratio

Bit 0 Reg. SC1	PS2	PS1	PS0	PRESCALER Ratio
0	0	0	0	1
0	0	0	1	2
0	0	1	0	4
0	0	1	1	8
0	1	0	0	16
0	1	0	1	32
0	1	1	0	64
0	1	1	1	128
1	0	0	0	3
1	0	0	1	6
1	0	1	0	12
1	0	1	1	24
1	1	0	0	48
1	1	0	1	96
1	1	1	0	192
1	1	1	1	384

Input Capture with ARTimer

THE SOFTWARE INCLUDED IN THIS NOTE IS FOR GUIDANCE ONLY. SGS-THOMSON SHALL NOT BE HELD LIABLE FOR ANY DIRECT, INDIRECT OR CONSEQUENTIAL DAMAGES WITH RESPECT TO ANY CLAIMS ARISING FROM USE OF THE SOFTWARE.

Information furnished is believed to be accurate and reliable. However, SGS-THOMSON Microelectronics assumes no responsibility for the consequences of use of such information nor for any infringement of patents or other rights of third parties which may result from its use. No license is granted by implication or otherwise under any patent or patent rights of SGS-THOMSON Microelectronics. Specifications mentioned in this publication are subject to change without notice. This publication supersedes and replaces all information previously supplied.

SGS-THOMSON Microelectronics products are not authorized for use as critical components in life support devices or systems without the express written approval of SGS-THOMSON Microelectronics.

© 1994 SGS-THOMSON Microelectronics - All rights reserved.

Purchase of I²C Components by SGS-THOMSON Microelectronics conveys a license under the Philips I²C Patent. Rights to use these components in an I²C system is granted provided that the system conforms to the I²C Standard Specification as defined by Philips.

SGS-THOMSON Microelectronics Group of Companies

Australia - Brazil - France - Germany - Hong Kong - Italy - Japan - Korea - Malaysia - Malta - Morocco - The Netherlands
Singapore - Spain - Sweden - Switzerland - Taiwan - Thailand - United Kingdom - U.S.A.



LittleDiode supplies new, hard to find or obsolete electronic components and semiconductors all over the world.

With over two million different components listed you are sure to find the part you need.

Feel free to visit us today at our online store:

LittleDiode.com

Looking forward to providing you with the best possible service.