

CROSSTALK BEHAVIOUR OF ITA25 IN RS232 TRANSMISSION

A Bremond

I - INTRODUCTION

Crosstalk is a digital interference phenomenon between data lines. The signal transmission by one data line produces parasitic voltages on nearby channels. These disturbances are due mainly to capacitive coupling or electro magnetic interference. This phenomenon occurs particularly when a great number of lines are located in a small area, notably in the case of multilane protection circuits having a high density.

The decrease of available area and the increase in the number of lines managed by a board forces the use of a single chip configuration to realize the protection function.

The goal of this paper is to quantify the parasitic effect of SGS-THOMSON monolithic protection products.

II - TEST DIAGRAM

To analyse the crosstalk behavior we will take as an example the most commonly-used interface : RS232.

Figure 1 : Test circuits

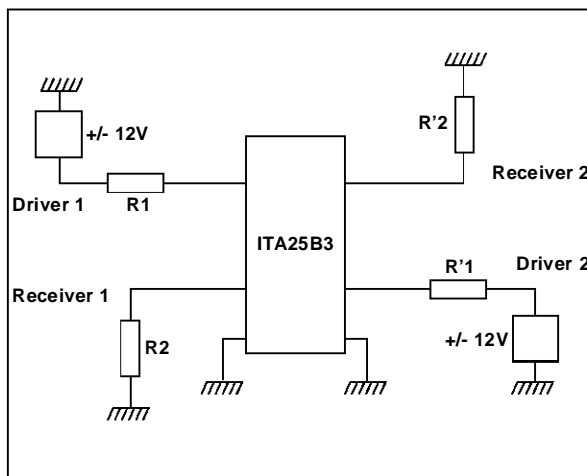

Figure 1 shows the test circuits used to do the crosstalk measurements.

The equivalent circuits of the drivers and receivers have been determined from the RS232C standard. So the following tests are done with :

$$R1 + R'1 = 500 \text{ Ohms and } R2 + R'2 = 3 \text{ k Ohms}$$

III - THEORETICAL ANALYSIS

Figure 2 : Equivalent diagram

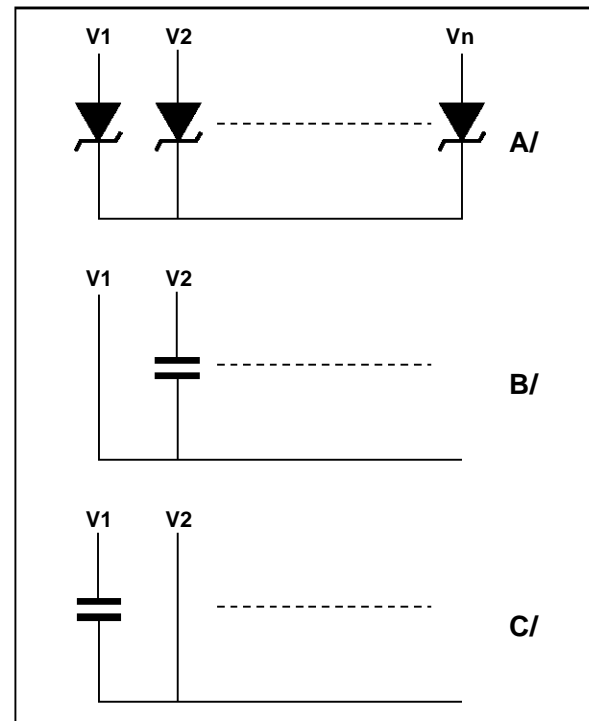

Figure 2 A/ shows the internal circuit diagram of the 8 way protection device ITA25. We see that the cathodes of all channels are common. If we consider the two adjacent lines V1 and V2, we note that when V1 is more positive than V2, both channels are connected through the off state capacitance of one of the diodes (see fig.2 B/).

We have the same phenomenon when V2 is more positive than V1 (see fig.2 C/).

APPLICATION NOTE

So the equivalent circuit of both driver and receiver lines is given by fig.3. This diagram shows the worse case, because the input resistance of the receiver 2 has not been taken into account and zero line capacitance has been assumed.

The simulation results using this equivalent circuit are given in figure 4.

The capacitance C is equal to 200 pF for a bias voltage of 12 V.

Figure 3 : Equivalent circuit of both driver and receiver adjacent lines

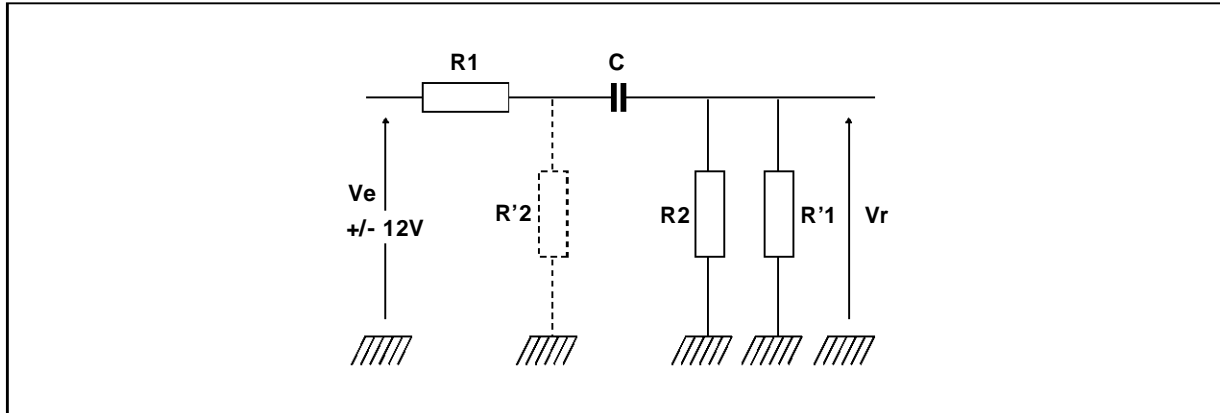
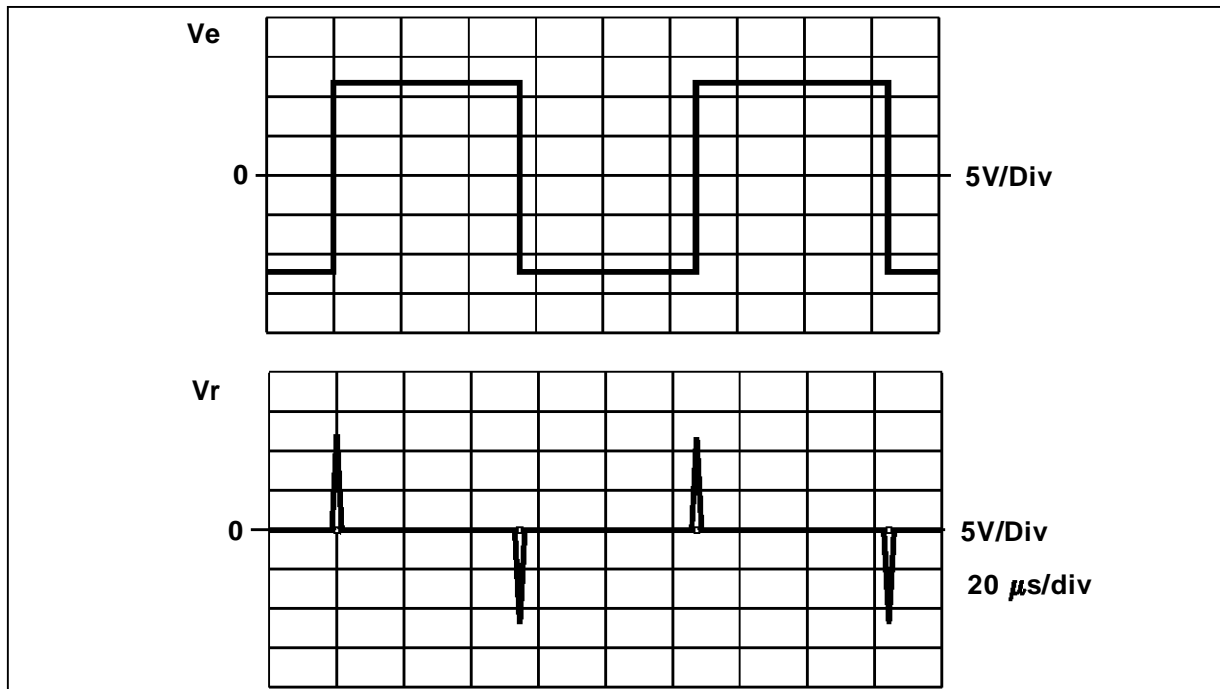

Figure 4 : Crosstalk simulation behavior



This simulation gives the following parameters :

- V_R peak : $\pm 11.7 V$
- Time constant : $0.2 \mu s$

Despite their large amplitude, these peaks would not cause any problems. Their short duration means that they would be filtered out by the RS232 input sampling operation.

IV - MEASUREMENTS

Figure 5 : Measurement circuits

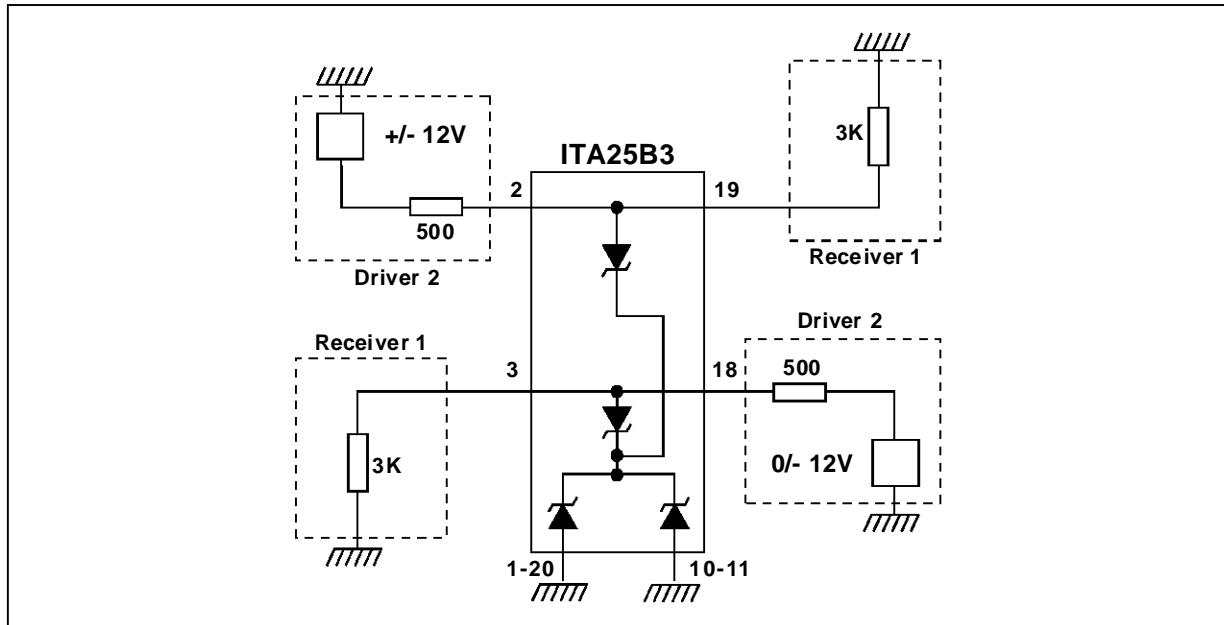

The measurements have been done in the figure 5 configuration. Three cases have been taken into account :

- DRIVER 2 output at -12 V (see fig.6)
- DRIVER 2 output at 0 V (see fig.7)
- DRIVER 2 output at +12 V (see fig.8)

Figure 6 : V_e/V_r with DRIVER 2 voltage = -12 V

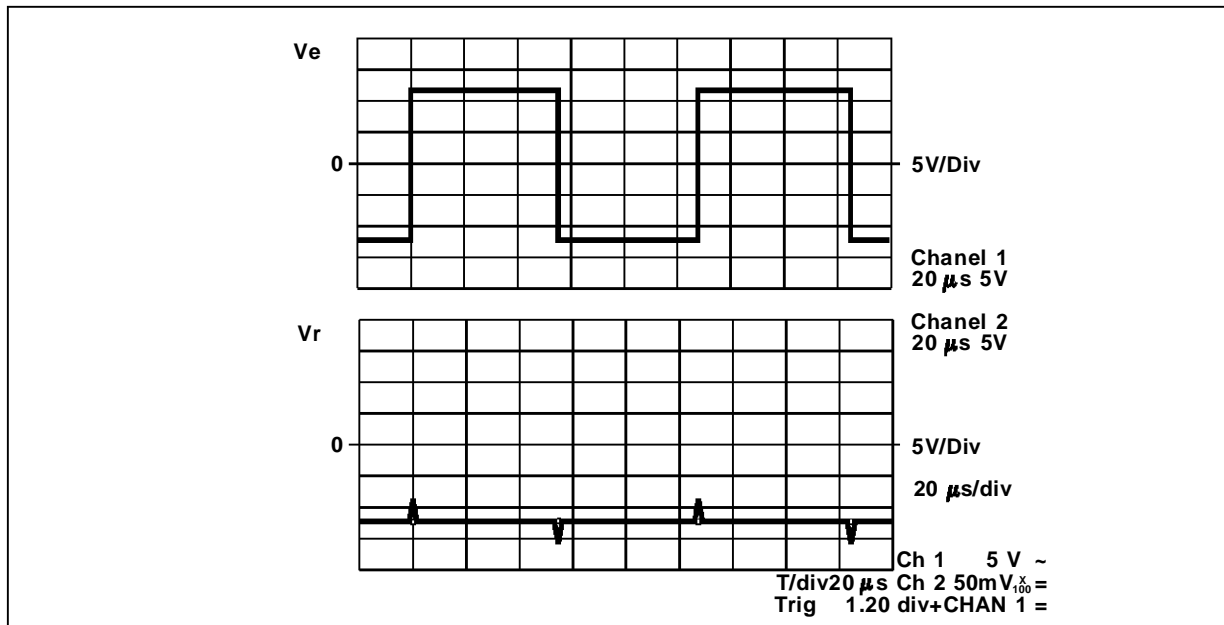

Figure 7 : V_e/V_R with DRIVER 2 voltage = 0 V

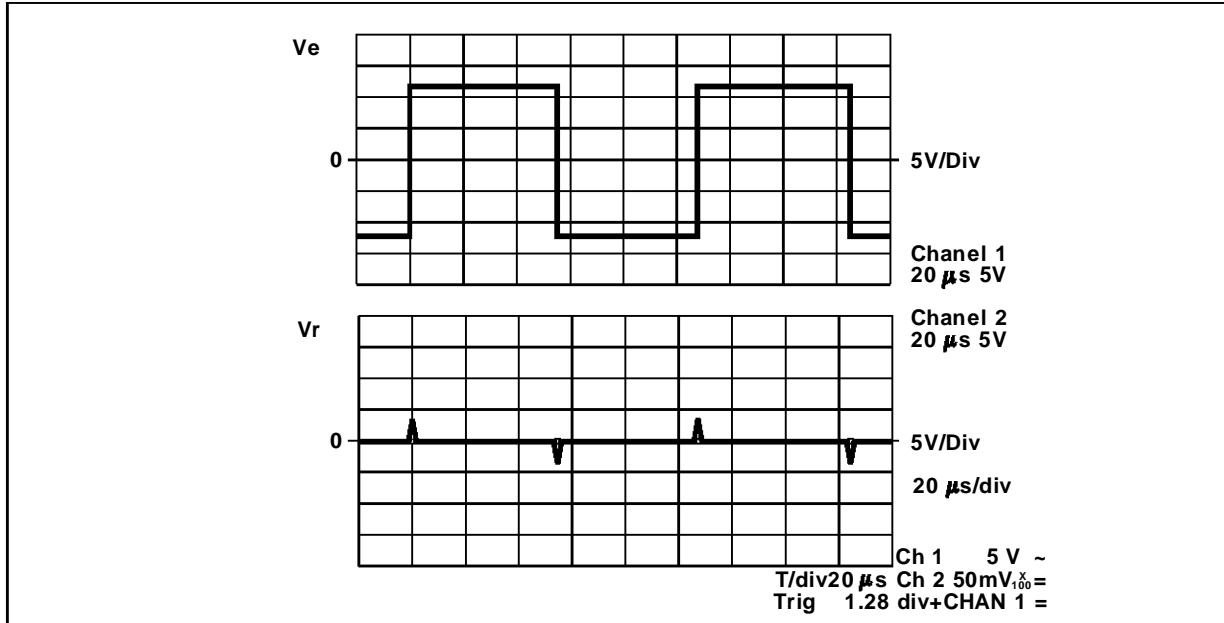
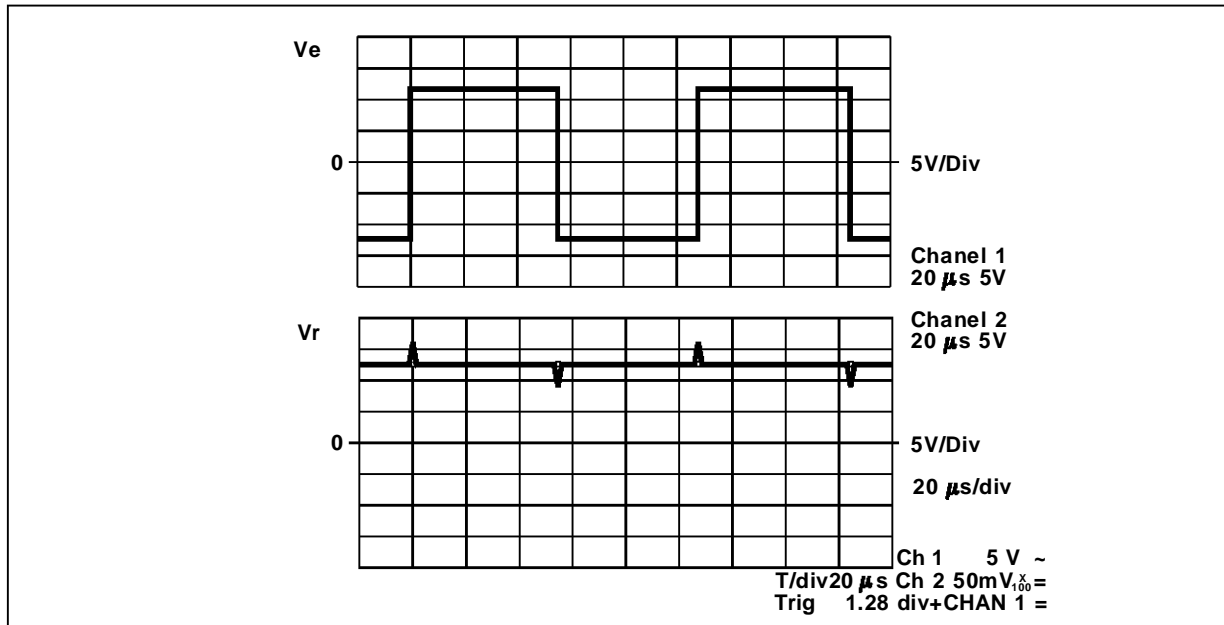

Figure 8 : V_e/V_R with DRIVER 2 voltage = 12 V



The waveforms of figs. 6, 7 and 8 show parasitic overvoltages lower than in the simulation. This is largely due to the presence of line capacitance and a finite input impedance. The duration of the

spikes is similar, so again they would be removed by the RS232 input sampling.

The expanded view of figure 7 given by figure 9 quantifies the duration of the phenomenon.

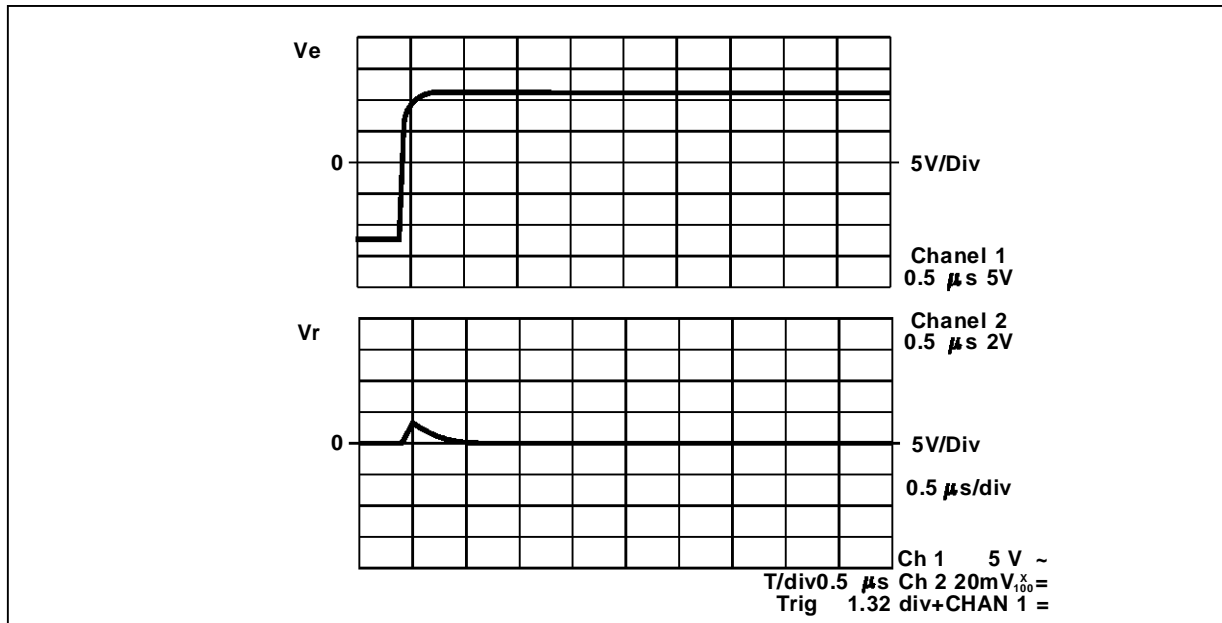
Figure 9 : Expanded view of V_e/VR with DRIVER 2 output = 0 V

V - DISTURBANCE EFFECTS - CONCLUSION

The measurements described in chapter IV show parasitic overvoltages of ± 3 V for a duration of about 0.4 μ s. These will not result in any corruption of data because of input sampling by the RS232 interface.

Information furnished is believed to be accurate and reliable. However, SGS-THOMSON Microelectronics assumes no responsibility for the consequences of use of such information nor for any infringement of patents or other rights of third parties which may result from its use. No license is granted by implication or otherwise under any patent or patent rights of SGS-THOMSON Microelectronics. Specifications mentioned in this publication are subject to change without notice. This publication supersedes and replaces all information previously supplied.

SGS-THOMSON Microelectronics products are not authorized for use as critical components in life support devices or systems without express written approval of SGS-THOMSON Microelectronics.

© 1995 SGS-THOMSON Microelectronics - Printed in Italy - All rights reserved.

SGS-THOMSON Microelectronics GROUP OF COMPANIES

Australia - Brazil - France - Germany - Hong Kong - Italy - Japan - Korea - Malaysia - Malta - Morocco -
The Netherlands - Singapore - Spain - Sweden - Switzerland - Taiwan - Thailand - United Kingdom - U.S.A.



LittleDiode supplies new, hard to find or obsolete electronic components and semiconductors all over the world.

With over two million different components listed you are sure to find the part you need.

Feel free to visit us today at our online store:

LittleDiode.com

Looking forward to providing you with the best possible service.