

AN5858K

Color-TV AV-Switch IC

■ Overview

The AN5858K is an AV switch IC. It switches five inputs (V, SY, SC, R, and L), and two outputs (TV and monitor). It has the most S-input-pins in the industry and can support many kind of high grade multi-function TV.

■ Features

- Supporting TVs with a BS tuner
- 4 channels of S-input
- Audio muting circuit built-in
- Oscillation preventing circuit built-in
- Black and white, or color switching function built-in

■ Applications

- TV

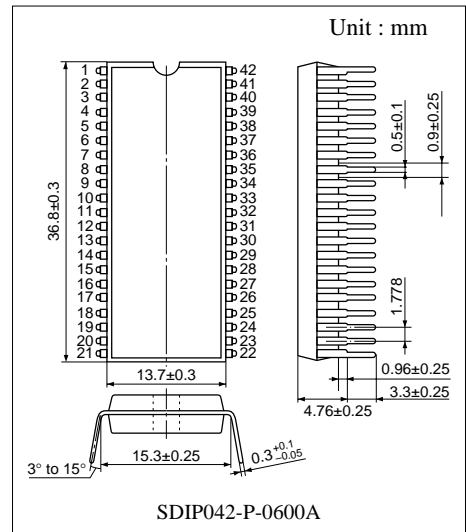

■ Block Diagram

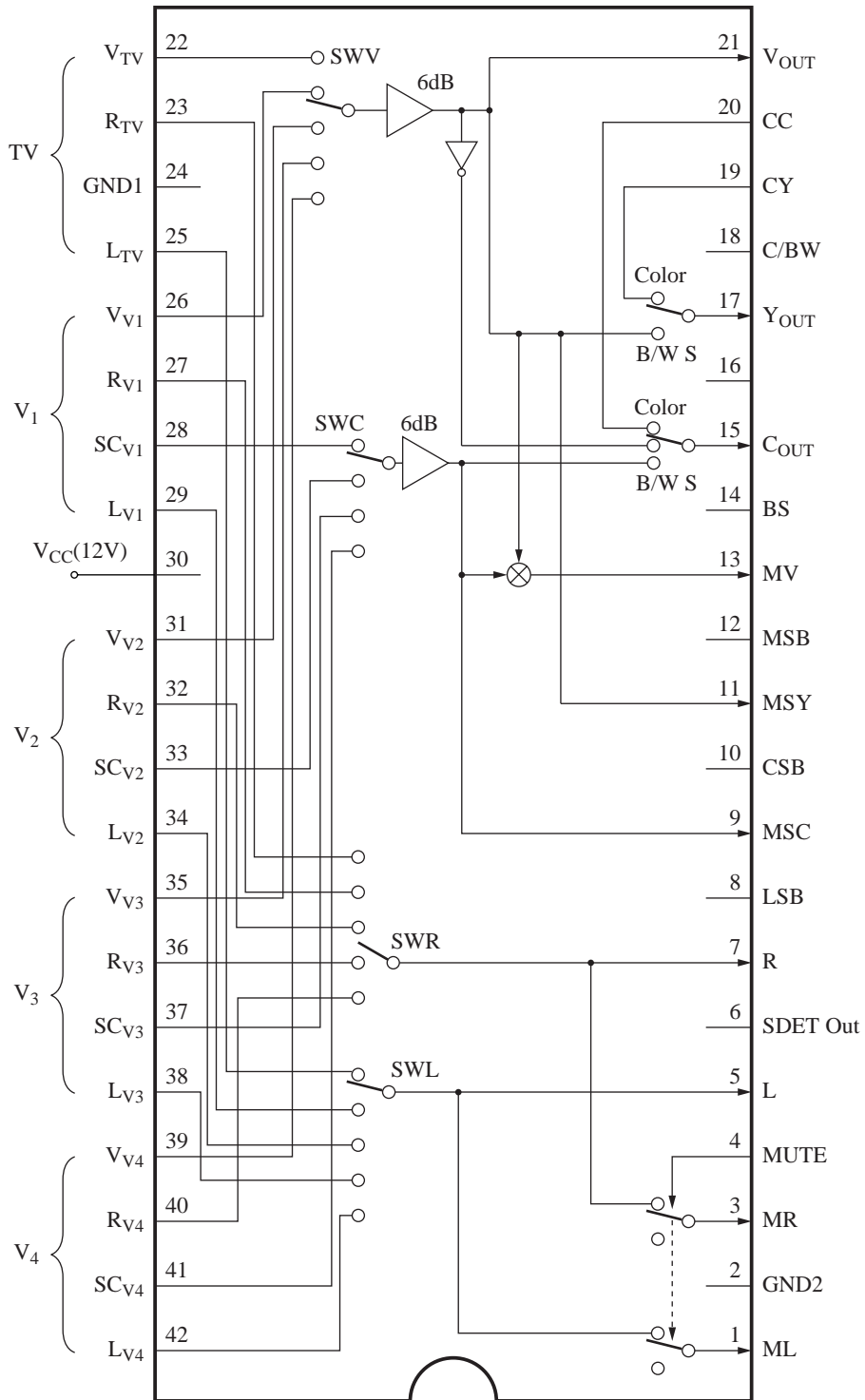

■ Pin Descriptions

Pin No.	Pin Name	Pin No.	Pin Name
1	L signal output (monitor)	22	TV video signal input
2	GND2	23	TV R signal input
3	R signal output (monitor)	24	GND1
4	Mute signal input	25	TV L signal input
5	L signal output	26	V ₁ brightness/video signal input
6	S mode discrimination output	27	V ₁ R signal input
7	R signal output	28	V ₁ chroma signal input
8	Mode change-over (LSB)	29	V ₁ L signal input
9	Chroma signal output (monitor)	30	Power supply
10	Mode change-over (CSB)	31	V ₂ brightness/video signal input
11	Brightness signal output (monitor)	32	V ₂ R signal input
12	Mode change-over (MSB)	33	V ₂ chroma signal input
13	Video signal output (monitor)	34	V ₂ L signal input
14	Forced BS/V ₁ defeat change-over	35	V ₃ brightness/video signal input
15	Chroma signal output	36	V ₃ R signal input
16	Defeat pulse generation	37	V ₃ chroma signal input
17	Brightness signal output	38	V ₃ L signal input
18	Color/black and white change-over	39	V ₄ brightness/video signal input
19	Comb filter brightness signal input	40	V ₄ R signal input
20	Comb filter chroma signal input	41	V ₄ chroma signal input
21	Video signal output	42	V ₄ L signal input

■ Absolute Maximum Ratings

Parameter	Symbol	Rating	Unit
Supply voltage	V_{CC}	13.5	V
Supply current	I_{CC}	60	mA
Power dissipation *2	P_D	810	mW
Operating ambient temperature *1	T_{opr}	-20 to +70	°C
Storage temperature *1	T_{stg}	-55 to +150	°C
Mode change-over terminal voltage	$V_{8,10,12}$	-0.3 to +5.5	V
Video signal input terminal voltage	$V_{22,26,31,35,39}$	-0.3 to $V_{30}+0.3$	V
Chroma signal input terminal voltage	$V_{28,33,37,41}$	-0.3 to $V_{30}+0.3$	V
R signal input terminal current	$I_{23,27,32,36,40}$	-15 to +15	mA
L signal input terminal current	$I_{25,29,34,38,42}$	-15 to +15	mA
Mute signal input terminal voltage	V_4	-0.3 to +5.5	V
Forced BS/ V_1 defeat change-over terminal voltage	V_{14}	-0.3 to $V_{30}+0.3$	V
Color/black and white change-over terminal voltage	V_{18}	-0.3 to $V_{30}+0.3$	V
S mode discrimination output change-over terminal voltage	V_6	0 to $V_{30}+0.3$	V
Comb filter brightness signal input terminal voltage	V_{19}	-0.3 to $V_{30}+0.3$	V
Comb filter chroma signal input terminal voltage	V_{20}	-0.3 to $V_{30}+0.3$	V

Note) Do not apply current or voltage from the outside to any pin not listed above.

In the circuit current, (+) means the current flowing into IC and(-) means the current flowing out of IC.

*1 : $T_a = 25\text{ °C}$ except power dissipation, operating ambient temperature and storage temperature.

*2 : Power dissipation of the package at $T_a = 70\text{ °C}$.

■ Recommended Operating Range

Parameter	Symbol	Range	Unit
Operating supply voltage range	V_{CC}	10.8 to 13.2	V

■ Electrical Characteristics at $T_a = 25\text{ }^\circ\text{C} \pm 2\text{ }^\circ\text{C}$

Parameter	Symbol	Conditions	Min	Typ	Max	Unit
Supply current	I_{30}	Pin30	25	34	43	mA
Video signal input terminal voltage	V_{IV}	Pin22, 26, 31, 35	2.5	3.0	3.5	V
Chroma signal input terminal voltage	V_{IC}	Pin28, 33, 37, 41	6.7	7.2	7.7	V
Audio signal input terminal voltage (R)	V_{IR}	Pin23, 27, 32, 36	6	6.5	7	V
Audio signal input terminal voltage (L)	V_{IL}	Pin25, 29, 34, 38	6	6.5	7	V
Comb filter luminance signal input terminal voltage	V_{I19}	Pin19	8.1	8.6	9.1	V
Comb filter chroma signal input terminal voltage	V_{I20}	Pin20	5.9	6.4	6.9	V
Video signal output terminal voltage	V_{O21}	Pin21	7.2	7.7	8.2	V
Video signal output terminal voltage (monitor)	V_{O13}	Pin13	6.5	7.0	7.5	V
Luminance signal output terminal voltage	V_{O17}	Pin17	7.2	7.7	8.2	V
Luminance signal output terminal voltage (monitor)	V_{O11}	Pin11	7.2	7.7	8.2	V
Chroma signal output terminal voltage	V_{O15}	Pin15	5.1	5.6	6.1	V
Chroma signal output terminal voltage (monitor)	V_{O9}	Pin9	7.1	7.6	8.1	V
Mode change-over terminal threshold voltage	V_{MOD}	Pin8, 10, 12	0.5	1.0	1.5	V
Mute terminal threshold voltage	V_{MUT}	Pin4	0.5	0.85	1.2	V
Forced BS threshold voltage	V_{BS}	Pin14	2.7	3.3	3.8	V
V_1 defeat threshold voltage	V_{DEF}	Pin14	0.6	0.9	1.2	V
Color/black and white change-over terminal voltage	$V_{C/W}$	Pin18	0.6	1.6	2.6	V
S-mode discrimination threshold voltage	V_S	Pin28, 33, 37, 41	4.5	5.3	6	V
S-mode discrimination output voltage	V_{SO}	Pin6	0	0.2	0.5	V
Video signal output offset voltage	ΔV_{21}	Pin21	0	5	100	mV
Video signal output offset voltage (monitor)	ΔV_{13}	Pin13	0	5	100	mV
Luminance signal output offset voltage	ΔV_{17}	Pin17	0	5	100	mV
Luminance signal output offset voltage (monitor)	ΔV_{11}	Pin11	0	5	100	mV
Chroma signal output offset voltage	ΔV_{15}	Pin15	0	5	100	mV
Chroma signal output offset voltage (monitor)	ΔV_9	Pin9	0	5	100	mV

■ Electrical Characteristics at $T_a = 25\text{ °C} \pm 2\text{ °C}$ (continued)

Parameter	Symbol	Conditions	Min	Typ	Max	Unit
Audio signal output offset voltage	ΔV_A	Pin5, 7	0	5	100	mV
Audio signal output offset voltage (monitor)	ΔV_{MA}	Pin1, 3	0	5	100	mV
Video signal voltage gain	G_V	Pin21	5	6	7	dB
Video signal voltage gain (monitor)	G_{MV}	Pin13	4.6	5.7	6.8	dB
Luminance signal voltage gain (\bar{S})	G_Y	Pin17	-1	0	1	dB
Luminance signal voltage gain (S)	G_{YS}	Pin11, 17	5	6	7	dB
Chroma signal voltage gain (\bar{S})	G_C	Pin15	-1	0	1	dB
Chroma signal voltage gain (S)	G_{CS}	Pin9, 15	4.4	5.8	7.2	dB
Audio signal voltage gain	G_A	Pin5, 7	-1	0	1	dB
Audio signal voltage gain (monitor)	G_{MA}	Pin1, 3	-1	0	1	dB
Total harmonics distortion rate (video)	THD _V	Pin11, 13, 17, 21	—	0.07	1.0	%
Crosstalk (audio)	CT _A	Pin1, 3, 5, 7	—	-100	-80	dB
Crosstalk (luminance)	CT _Y	Pin11, 13, 17, 21	—	-64	-50	dB
Crosstalk (chroma)	CT _C	Pin9, 15	—	-60	-46	dB
Defeat pulse charge current	I_{O16}	Pin16	-0.13	-0.1	-0.07	mA
Defeat pulse discharge current	I_{I16}	Pin16	0.6	0.9	1.2	mA
Defeat pulse threshold voltage	V_{TH16}	Lowest voltage at which defeat pulse does not emerge	2.1	2.6	3.1	V
Video signal frequency characteristics	f_{CV}	Pin21, -3 dB	10	13	—	MHz
Video signal frequency characteristics (monitor)	f_{CMV}	Pin13, -3 dB	8	11	—	MHz
Luminance signal frequency characteristics	f_{CY}	Pin17, -3 dB	10	13	—	MHz
Luminance signal frequency characteristics (monitor)	f_{CMY}	Pin11, -3 dB	10	13	—	MHz
Audio signal frequency characteristics	f_{CA}	Pin1, 3, 5, 7, -3 dB	1	—	—	MHz
Audio signal input terminal voltage (R ₄ , L ₄)	V_{IA4}	Pin40, 42	6.5	7.0	7.5	V
Video signal input terminal voltage (V ₄)	V_{IV4}	Pin39	3.2	3.7	4.2	V

■ Electrical Characteristics at $T_a = 25\text{ °C} \pm 2\text{ °C}$ (continued)

• Design reference data

Note) The characteristic values below are theoretical values for designing and not guaranteed.

Parameter	Symbol	Conditions	Min	Typ	Max	Unit
Video output noise voltage	V_{NV}	Pin21 bandwidth 10 MHz	0	0.5	1.0	mV_{rms}
Video output noise voltage (monitor)	V_{NMV}	Pin13 bandwidth 10 MHz	0	0.5	1.0	mV_{rms}
Luminance output noise voltage	V_{NY}	Pin17 bandwidth 10 MHz	0	0.5	1.0	mV_{rms}
Luminance output noise voltage (monitor)	V_{NMY}	Pin11 bandwidth 10 MHz	0	0.5	1.0	mV_{rms}
Chroma output noise voltage	V_{NC}	Pin15 bandwidth 10 MHz	0	0.5	1.0	mV_{rms}
Chroma output noise voltage (monitor)	V_{NMC}	Pin9 bandwidth 10 MHz	0	0.5	1.0	mV_{rms}
Audio output noise voltage	V_{NA}	Pin5, 7 bandwidth 15 kHz	0	5	50	μV_{rms}
Audio output noise voltage (monitor)	V_{NMA}	Pin1, 3 bandwidth 15 kHz	0	5	50	μV_{rms}
Input impedance 1	R_{IA}	Pin23, 25, 27, 29, 32, 34, 36, 38, 40, 42	55	75	95	$\text{k}\Omega$
Input impedance 2	R_{IY}	Pin19, 22, 26, 31, 35, 39	16	21	26	$\text{k}\Omega$
Input impedance 3	R_{IC}	Pin20, 28, 33, 37, 41	16	21	26	$\text{k}\Omega$
Output impedance 1	R_{OA}	Pin1, 3, 5, 7	30	60	90	Ω
Output impedance 2	R_{OV}	Pin21	22	45	68	Ω
Output impedance 3	R_{OY}	Pin11, 13, 15, 17	30	60	90	Ω
Output impedance 4	R_{OC}	Pin9	80	160	240	Ω
Total harmonics distortion rate (Audio)	THD_A	Pin1, 3, 5, 7	—	0.005	0.01	%
Video signal input dynamic range	D_{IY}	f = 10 kHz, distortion rate 1 % Pin22, 26, 31, 35, 39	2.2	2.6	—	V
Chroma signal input dynamic range	D_{IC}	f = 10 kHz, distortion rate 1 % Pin28, 33, 37, 41	1.1	1.3	—	V
Audio signal input dynamic range (R)	D_{IR}	f = 1 kHz, distortion rate 1 % Pin23, 27, 32, 36	7.2	8.0	—	V
Audio signal input dynamic range (L)	D_{IL}	f = 1 kHz, distortion rate 1 % Pin25, 29, 34, 38	7.2	8.0	—	V
Comb filter Y input dynamic range	D_{I19}	f = 10 kHz, distortion rate 1 % Pin19	6.0	—	—	V
Comb filter C input dynamic range	D_{I20}	f = 10 kHz, distortion rate 1 % Pin20	6.0	—	—	V

■ Basic Circuit

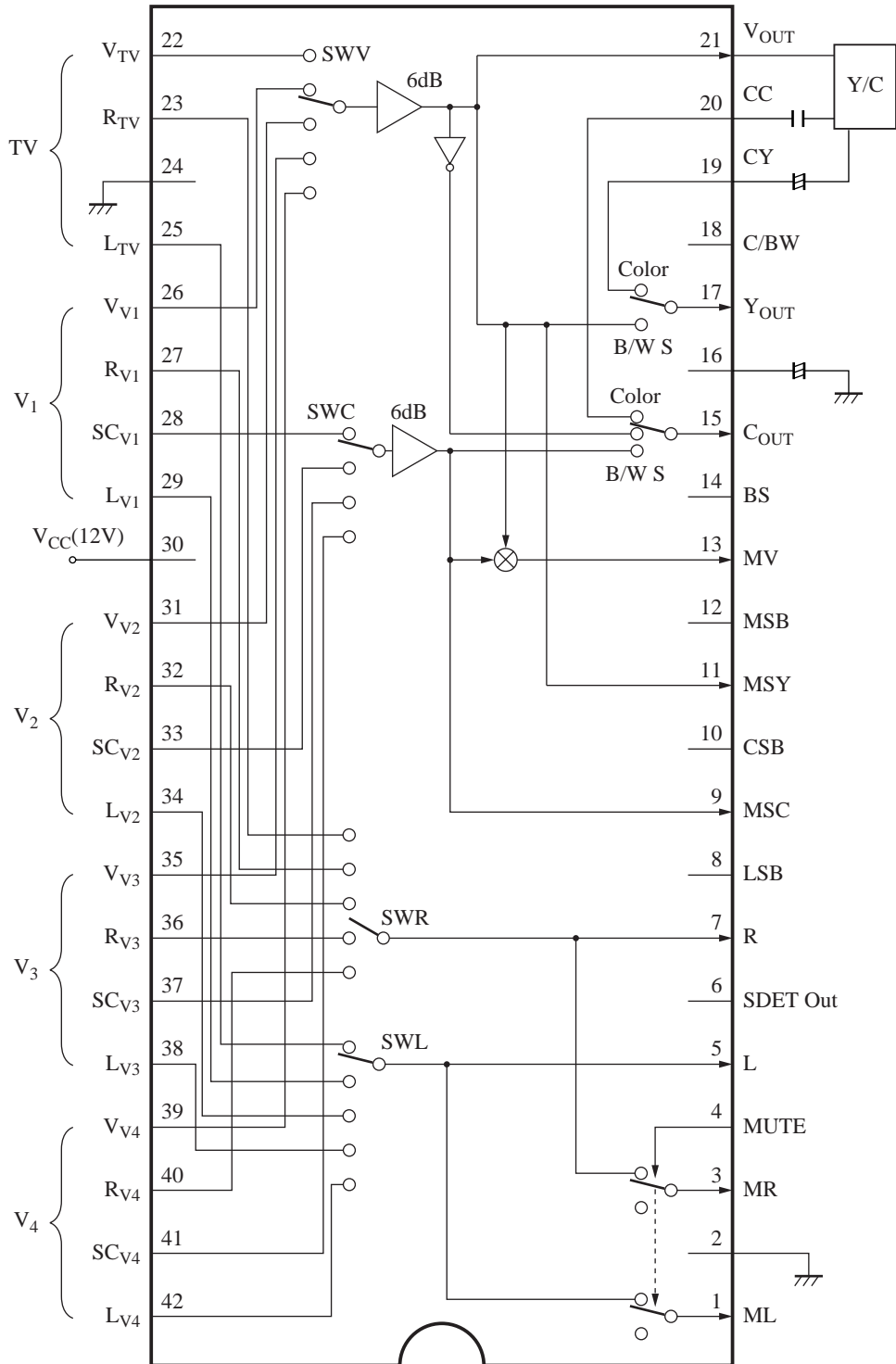



LittleDiode supplies new, hard to find or obsolete electronic components and semiconductors all over the world.

With over two million different components listed you are sure to find the part you need.

Feel free to visit us today at our online store:

LittleDiode.com

Looking forward to providing you with the best possible service.