

AN5826NK

TV Multiplex Sound System Demodulator Circuit

Outline

The AN5826NK is an integrated circuit designed for TV multiplex sound system demodulator circuit.

Features

- Including multiplex sound signal processing circuit on a single chip, for easier compact set design
- Sub signal demodulator circuits free from signal adjustment
- Lead filter not required

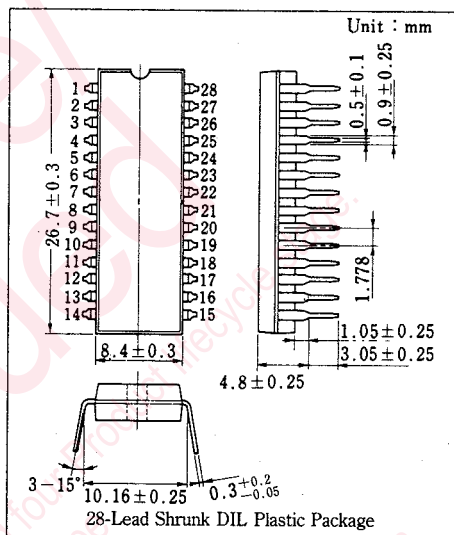

Block Diagram

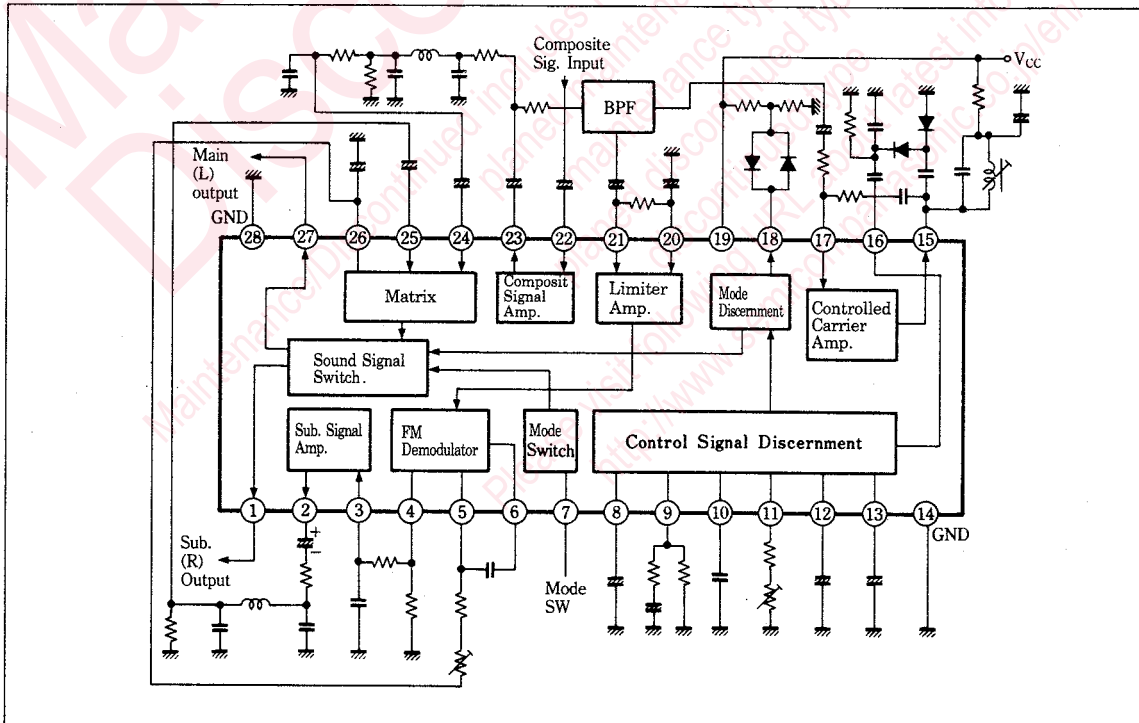

■ Pin

| Pin No. | Pin Name | Pin No. | Pin Name |
|---------|--|---------|------------------------------|
| 1 | Sub(R)Sound Signal Output | 15 | Controlled Sub Signal Output |
| 2 | Sub Signal Output | 16 | Controlled Signal Input |
| 3 | Sub Signal Input | 17 | Controlled Sub Signal Output |
| 4 | Sub Signal Discriminator Output | 18 | Mode Display Output |
| 5 | Mono Multi Oscillator | 19 | V _{cc} |
| 6 | Mono Multi Oscillator | 20 | Filter |
| 7 | Mode Switch Input | 21 | Sub Signal Input |
| 8 | Filter | 22 | Composite Signal Output |
| 9 | Sound Multiplex Discernment Filter | 23 | Composite Signal Output |
| 10 | Filter | 24 | Main Sound Signal Input |
| 11 | 952.5Hz Oscillator | 25 | Sub Sound Signal Input |
| 12 | $\frac{982.5\text{Hz}}{922.5\text{Hz}}$ Discernment Filter | 26 | Bias Filter |
| 13 | Filter | 27 | Main(L)Sound Signal Output |
| 14 | GND | 28 | GND |

■ Absolute Maximum Ratings(Ta=25°C)

| Item | Symbol | Rating | Unit |
|-------------------|-------------------------------|------------------|---------------|
| Supply Voltage | V _{CC} | +14.4 | V |
| Circuit Current | I | 76 | mA |
| Power Dissipation | P _D | 1 100 | mW |
| Temperature | Operating Ambient Temperature | T _{opr} | -20 ~ +70 °C |
| | Storage Temperature | T _{stg} | -55 ~ +150 °C |

■ Electrical Characteristics(Ta=25°C)

| Item | Symbol | Test Circuit | Condition | min. | typ. | max. | Unit | |
|---|------------------------------------|------------------|--|----------------------|-------|-------|-------------------|----|
| Total Circuit Current | Mono | I _{CC1} | 1 | V _{CC} =12V | 30 | 42 | 55 | mA |
| | Multi | I _{CC2} | 1 | V _{CC} =12V | 36 | 48 | 62 | mA |
| Composite Signal Voltage Gain. | G _V | 1 | Pin②input 200mV _{p-p} 1kHz, Pin③output | 2.4 | 3.7 | 4.9 | dB | |
| Total Harmonic Distortion | THD _(typ) | 1 | Pin②input 200mV _{p-p} 1kHz, Pin③output | | 0.45 | 0.6 | % | |
| Total Harmonic Distortion | THD _(max) | 1 | Pin②input 3V _{p-p} 1kHz, Pin③output | | 0.85 | 1.0 | % | |
| Sub Signal Detect Max. Output Voltage | V _{sub(max)} | 1 | Pin②input 100%, Mod.400Hz | 880 | 1 150 | 1 500 | mV _{rms} | |
| VCO Oscillation Frequency | f _{osc} | 1 | V _{CC} =12V, GND with Pin①1kΩ, Monaural mode is set when standard sample is 952Hz | 857 | 952 | 1 047 | Hz | |
| fosc Change with Supply Voltage | Δf _{osc} /V _{CC} | 1 | V _{CC} =12V±20%, for V _{CC} =12V | -3 | 0 | +3 | Hz/V | |
| fosc Change with ambient Temperature | Δf _{osc} /Ta | 1 | Ta=-20~+70°C, for Ta=+25°C | -10 | 0 | +10 | Hz | |
| Capture Range(Stereo side) | CR _(ST) | 1 | Pin④0.5V _{rms} frequency variable | | 67 | 170 | Hz | |
| Capture Range(Dual side) | CR _(MU) | 1 | Pin④0.5V _{rms} frequency variable | -170 | -70 | | Hz | |
| Main(L)Output DC Offset Level | V _{O(offset-L)} | 1 | V _{CC} =12V, Input invalid signal, Output level difference for each mode | | 50 | 120 | mV | |
| Sub(R)Output DC Offset Level | V _{O(offset-R)} | 1 | V _{CC} =12V, Input invalid signal, Output level difference for each mode | | 50 | 120 | mV | |
| Main/Sub Output High Frequency Distortion | THD _(L,R) | 1 | V _{CC} =12V, Pin②input 100mV _{rms} , 1kHz | | 0.2 | 0.45 | % | |
| Main(L)Output Stereo Separation | Sep _(Main) | 1 | Pin ④, ⑤ 1kHz, Opposite phase | 40 | 50 | | dB | |
| Sub(R)Output Stereo Separation | Sep _(Sub) | 1 | Pin ④, ⑤ 1kHz, Same-phase | 40 | 50 | | dB | |
| Main(L) Output Dual Crosstalk | CT _(R-L) | 1 | Pin ④, ⑤ 1kHz | 50 | 60 | | dB | |
| Sub(R)Output Crosstalk | CT _(L-R) | 1 | Pin ④, ⑤ 1kHz | 50 | 60 | | dB | |
| Output Noise Voltage | V _{no} | 1 | V _{CC} =12V, Monaural mode | | 0.17 | 0.3 | mV _{rms} | |

Test Circuit 1

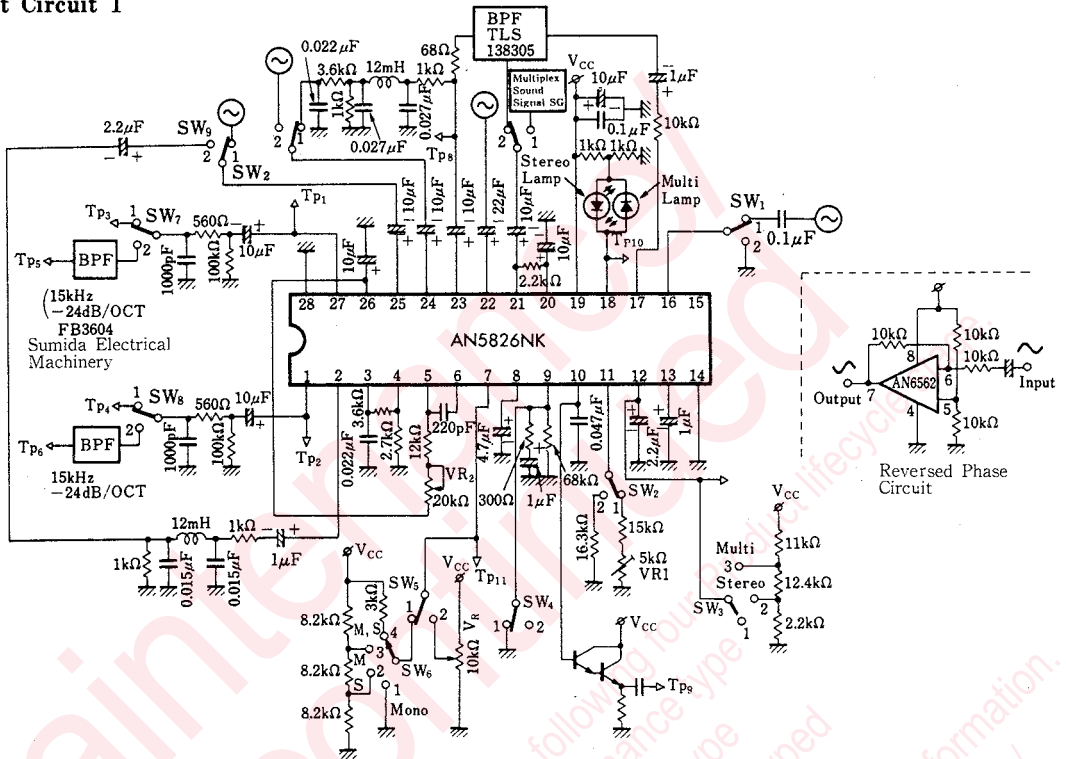

Application Circuit

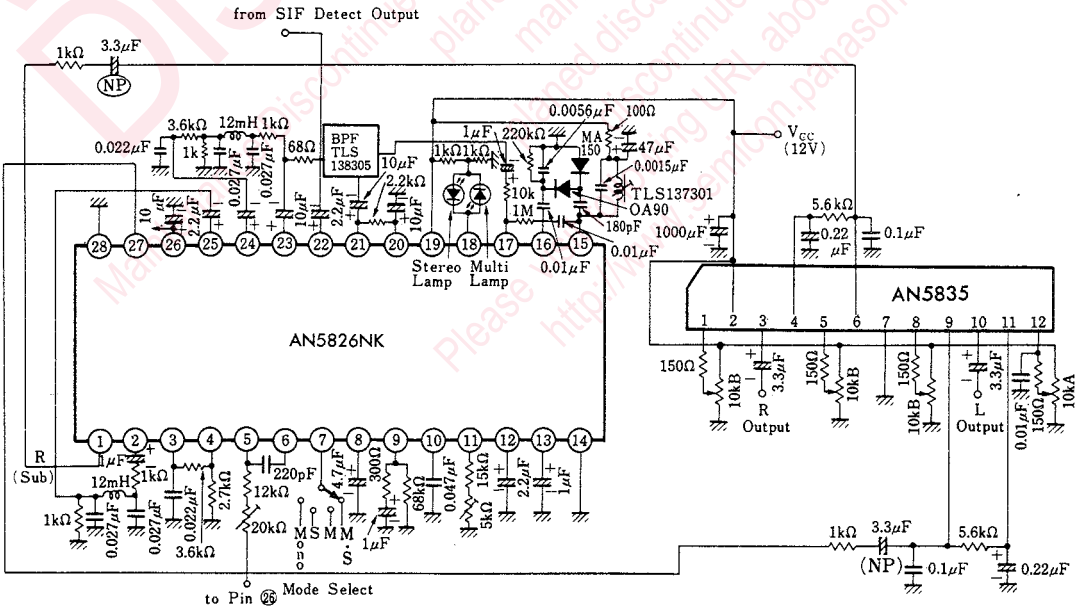

Request for your special attention and precautions in using the technical information and semiconductors described in this book

- (1) If any of the products or technical information described in this book is to be exported or provided to non-residents, the laws and regulations of the exporting country, especially, those with regard to security export control, must be observed.
- (2) The technical information described in this book is intended only to show the main characteristics and application circuit examples of the products. No license is granted in and to any intellectual property right or other right owned by Panasonic Corporation or any other company. Therefore, no responsibility is assumed by our company as to the infringement upon any such right owned by any other company which may arise as a result of the use of technical information described in this book.
- (3) The products described in this book are intended to be used for standard applications or general electronic equipment (such as office equipment, communications equipment, measuring instruments and household appliances).
Consult our sales staff in advance for information on the following applications:
 - Special applications (such as for airplanes, aerospace, automobiles, traffic control equipment, combustion equipment, life support systems and safety devices) in which exceptional quality and reliability are required, or if the failure or malfunction of the products may directly jeopardize life or harm the human body.
 - Any applications other than the standard applications intended.
- (4) The products and product specifications described in this book are subject to change without notice for modification and/or improvement. At the final stage of your design, purchasing, or use of the products, therefore, ask for the most up-to-date Product Standards in advance to make sure that the latest specifications satisfy your requirements.
- (5) When designing your equipment, comply with the range of absolute maximum rating and the guaranteed operating conditions (operating power supply voltage and operating environment etc.). Especially, please be careful not to exceed the range of absolute maximum rating on the transient state, such as power-on, power-off and mode-switching. Otherwise, we will not be liable for any defect which may arise later in your equipment.
 - Even when the products are used within the guaranteed values, take into the consideration of incidence of break down and failure mode, possible to occur to semiconductor products. Measures on the systems such as redundant design, arresting the spread of fire or preventing glitch are recommended in order to prevent physical injury, fire, social damages, for example, by using the products.
- (6) Comply with the instructions for use in order to prevent breakdown and characteristics change due to external factors (ESD, EOS, thermal stress and mechanical stress) at the time of handling, mounting or at customer's process. When using products for which damp-proof packing is required, satisfy the conditions, such as shelf life and the elapsed time since first opening the packages.
- (7) This book may be not reprinted or reproduced whether wholly or partially, without the prior written permission of our company.



LittleDiode supplies new, hard to find or obsolete electronic components and semiconductors all over the world.

With over two million different components listed you are sure to find the part you need.

Feel free to visit us today at our online store:

LittleDiode.com

Looking forward to providing you with the best possible service.