

PROTECTION SCHEMATICS FOR TELEPHONE SETS

C. Politano

INTRODUCTION

The type of telephone set that is being protected must first be identified.

A telephone set connected to a public network must be able to withstand surges described in standards such as CCITTK17, VDE0433, I3121, etc.

A telephone set connected to a private network is subjected to much less severe surge conditions.

In each case, SGS-THOMSON offers a suitable protection solution based on crowbar devices which can provide a very high surge current capability (from 30 Amp. to 100 Amp., 10/1000µs pulse width).

Table 1 below shows the complete product range available for telephone set protection.

Table 1 : Telephone set protection product range

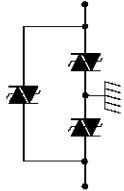
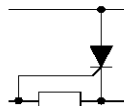
TRISIL			3 TERMINAL TRISIL		GATE TRIGGERED SUPPRESSOR (current limitation)	
						
AXIAL	SOD	DIL8	SO8	DIL8	SO8	DIL8
50A TPAxx 100A TPBxx	50A SMTPAxx 100A SMTPBxx	100A @10/1000µS LS5018B LS5060B LS5120B	THBT15011 THBT20011 THBT27011	THBT15012 THBT20012 THBT27012	30A @ 10/1000µS TPP25011	30A @ 10/1000µS TPP25012 100A@10/1000µS L3100B1

1. CHOICE OF THE PROTECTION DEVICE:

To choose the right protection device, the user will have to determine the following characteristics :

- 1) Surge current capability
- 2) Functional parameters

1.1. Surge current capability

There are two kinds of disturbances which have to be evaluated in order to define correctly the surge current capability of the protection device :

I.1.1. Protection against short duration disturbances :

These are transient overvoltages, which are specified in telecom standards such as CCITT k17, VDE04-33, I3121. The typical voltage waveforms are the 10/700µs and the 1.2/ 50µs types.

The user has to take care that the protection standard specifies voltage pulse waveforms, which have to be converted into pulse current waveforms. Thus he will obtain the peak surge current value I_{pp} which has to be withstood by the protection device.

(See application note 2.2 : Voltage to current waveform conversion).

APPLICATION NOTE

I.1.2. Protection against long duration disturbances.

In this case, the standards can be very different from one country to another, and the duration of the superimposed mains on telephone lines can reach more than 10 minutes with a current of around 8A. Obviously, it is not possible to withstand such surges with a plastic component. An economical and reliable solution is to use a PTC (positive temperature coefficient thermistor). These PTC devices with 10 Ω resistance (at 25°C) can reach a few k during the surge. The switching time depends on the surge current and the PTC. Nevertheless, most PTCs tested with an alternating surge current of 8 A react in 10 to 100 ms. Such a device could therefore be combined with a TPA Trisil which is able to withstand 8 A for 150 ms without any problem (see data sheet). In case of higher current the TPB versions should be used.

In conclusion, Trisil + PTC thermistor is the best performance / cost compromise for the subscriber telephone set protection.

1.2. Functional parameters :

To select the right CROWBAR protection, three main parameters have to be defined according to the application (see fig.1) :

- The minimum breakdown voltage : V_{BR}
- The maximum breakover voltage : V_{BO}
- The minimum holding current : I_H

Figure 1 : Crowbar protection electrical parameters

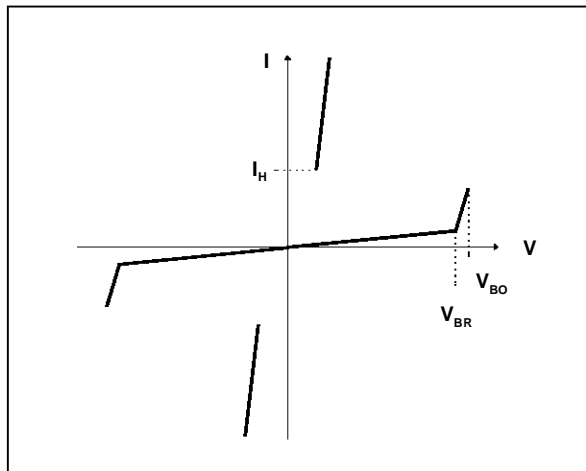

I.2.1. The breakdown voltage : V_{BR}

The V_{BR} has to be greater than the maximum v

voltage value which will be supplied in the line.

This condition will guarantee that the protection is not activated in the normal operating mode (no overvoltage).

I.2.2. The breakover voltage : V_{BO}

The breakover voltage (V_{BO}) has to be lower than the max-ratings of the component to be protected. This level is reached just before the protection device switches to the ON-STATE. The duration of the residual transient linked to the break-over voltage is very short : it does not exceed 1 μ s.

I.2.3. The holding current : I_H

When a crowbar device is used for protection, it is absolutely necessary to ensure that the holding current is higher than the maximum current available in the Telecom line. If this criterion is not obeyed, the Trisil triggers but does not return correctly to its blocked state after the disturbance.

Since the Trisil voltage in the conduction state is low, the condition can be expressed by the inequality $I_H > (V_L/R)$. See fig.2.

Figure 2 : Equipment protection by Trisil

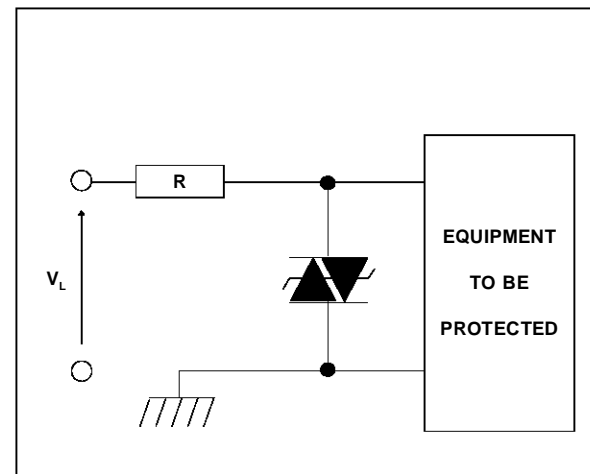

This is shown in figure 3 where the current does not drop below the holding current. The Trisil cannot return to the blocked state and thus remains as a quasi short-circuit, preventing operation of the equipment to be protected.

In the case of figure 4, the current drops below the value of the holding current and the internal mechanism of the Trisil enables it to return to the blocked state after the current surge.

Figure 3 : Wrong choice of the Trisil

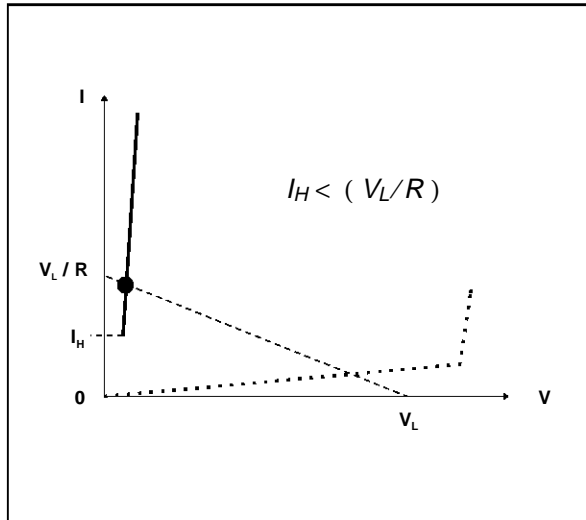
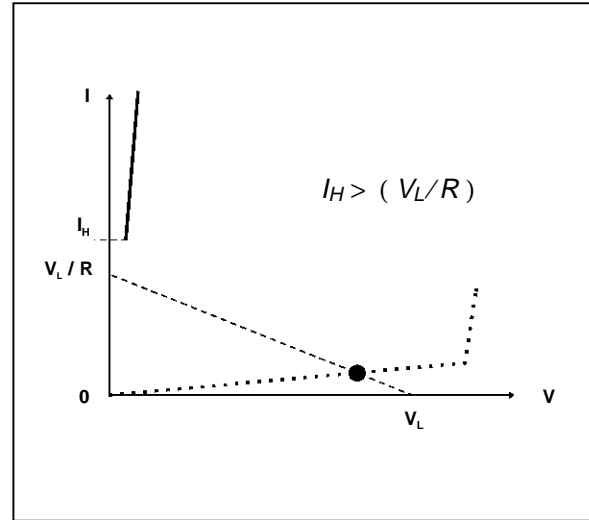

Figure 4 : Right choice of the Trisil



2. APPLICATION DIAGRAMMS :

Fig. 5 to 8 show typical protection solutions used for telephone sets and other terminals.

Figure 5 : Ring and speech circuit protection

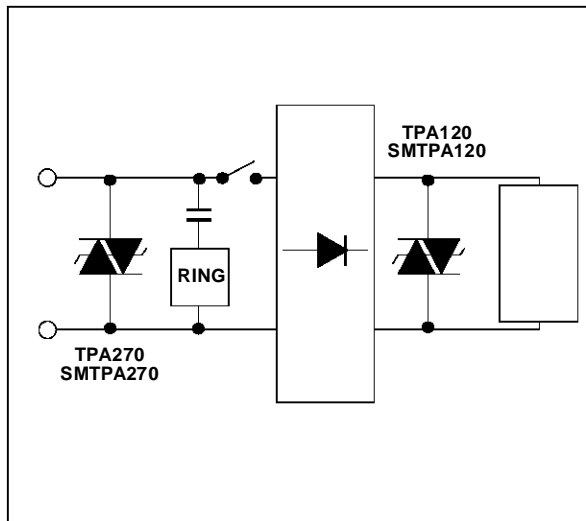
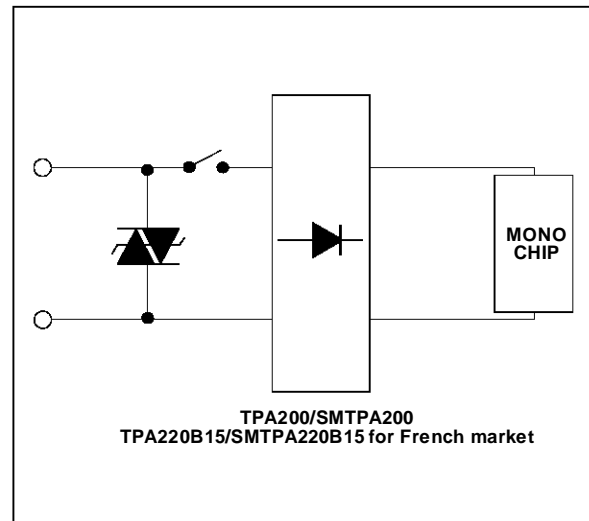

Figure 6 : Monochip circuit protection



APPLICATION NOTE

Figure 7a : Overvoltage protection and current limitation ($I_{PP} = 100\text{ A } 10/1000\ \mu\text{s}$)

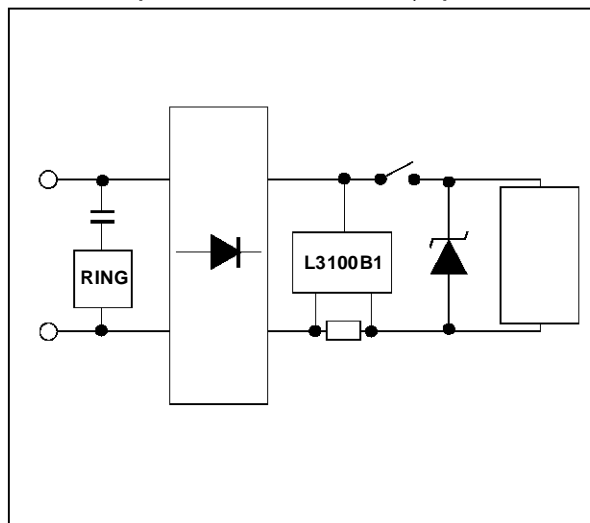

Figure 7b : Overvoltage protection and current limitation ($I_{PP} = 30\text{ A } 10/1000\text{ ms}$)

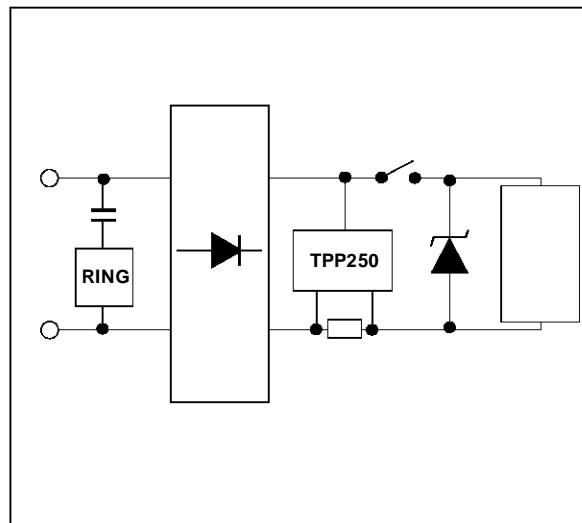

Figure 8a : Electronic hook switch protection

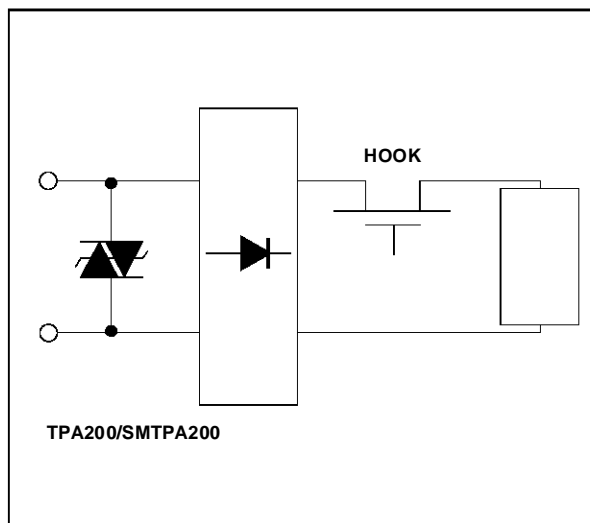

Figure 8b : Electronic hook switch protection

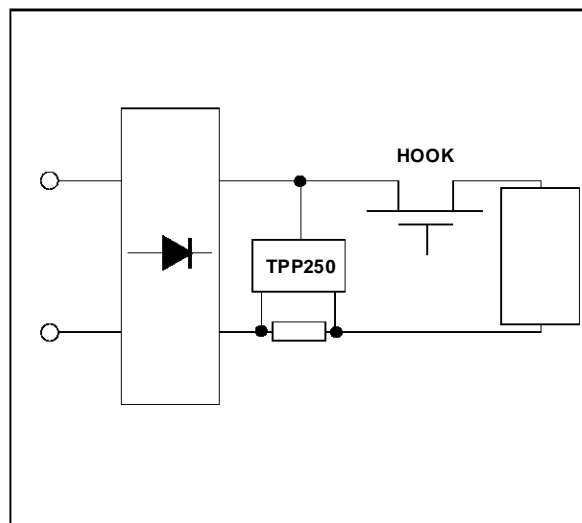
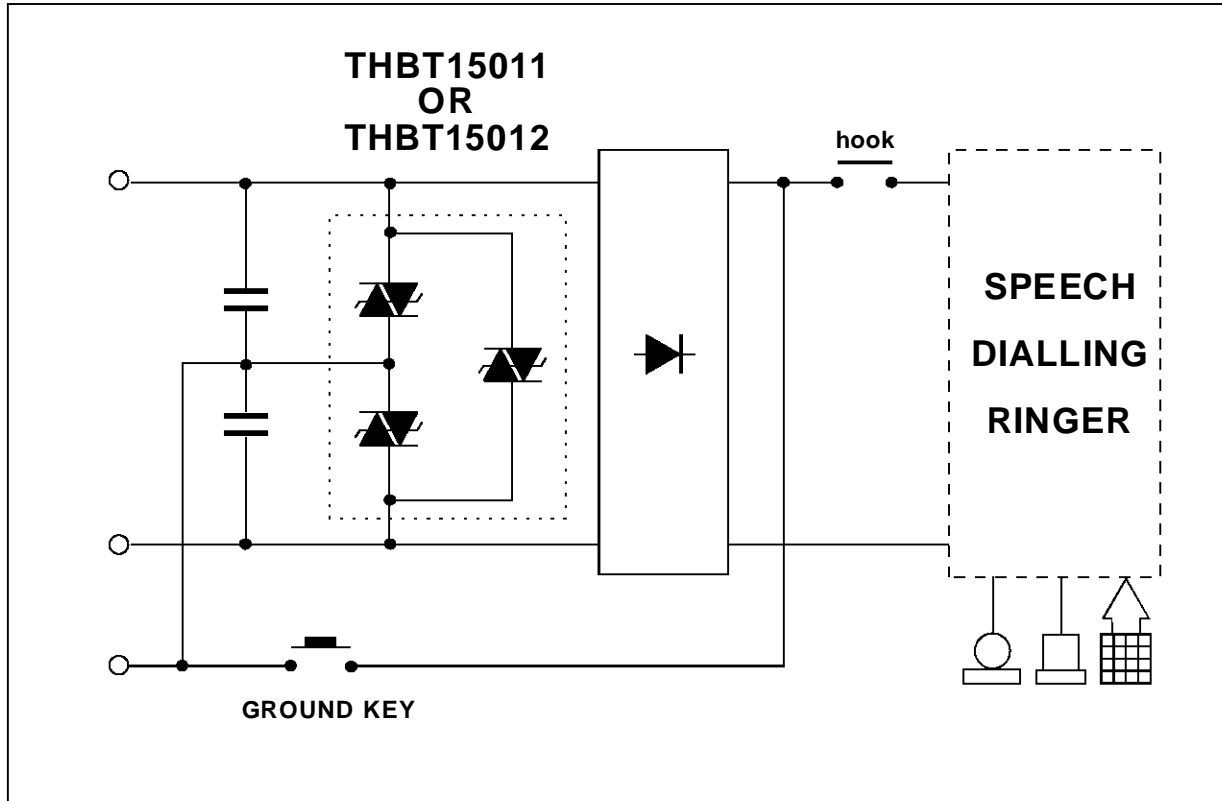

Figure 9 : German version with ground key



3. CONCLUSION

Whether the telephone set is connected to a public or private network, SGS-THOMSON offers a range of protection devices to cover all relevant standards.

Information furnished is believed to be accurate and reliable. However, SGS-THOMSON Microelectronics assumes no responsibility for the consequences of use of such information nor for any infringement of patents or other rights of third parties which may result from its use. No license is granted by implication or otherwise under any patent or patent rights of SGS-THOMSON Microelectronics. Specifications mentioned in this publication are subject to change without notice. This publication supersedes and replaces all information previously supplied.

SGS-THOMSON Microelectronics products are not authorized for use as critical components in life support devices or systems without express written approval of SGS-THOMSON Microelectronics.

© 1995 SGS-THOMSON Microelectronics - Printed in Italy - All rights reserved.

SGS-THOMSON Microelectronics GROUP OF COMPANIES

Australia - Brazil - France - Germany - Hong Kong - Italy - Japan - Korea - Malaysia - Malta - Morocco -
The Netherlands - Singapore - Spain - Sweden - Switzerland - Taiwan - Thailand - United Kingdom - U.S.A.



LittleDiode supplies new, hard to find or obsolete electronic components and semiconductors all over the world.

With over two million different components listed you are sure to find the part you need.

Feel free to visit us today at our online store:

LittleDiode.com

Looking forward to providing you with the best possible service.