

AN5636K

SECAM/PAL signal conversion IC

■ Overview

The AN5636K is an IC which converts the SECAM signal into the quasi-PAL signal. This IC can add the SECAM signal processing function while rationalizing the external parts in a joint use with the PAL/NTSC signal processing IC: AN5606K.

■ Features

- Rationalizing IHDL in common use with PAL IHDL
- Lowering 6H line crawling by the quasi-PAL modulation
- For both auto and manual modes of signal processing

■ Applications

- TV (applicable to three systems: PAL/NTSC/SECAM)

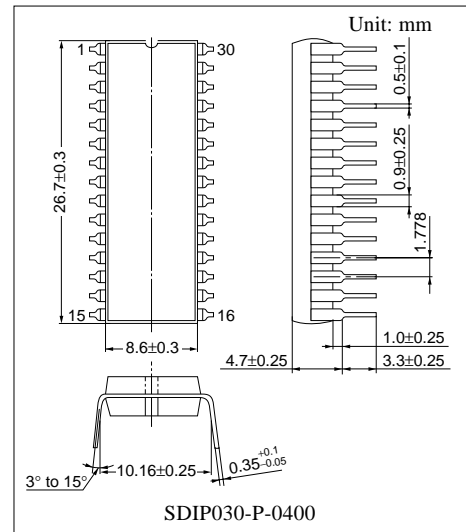

■ Block Diagram

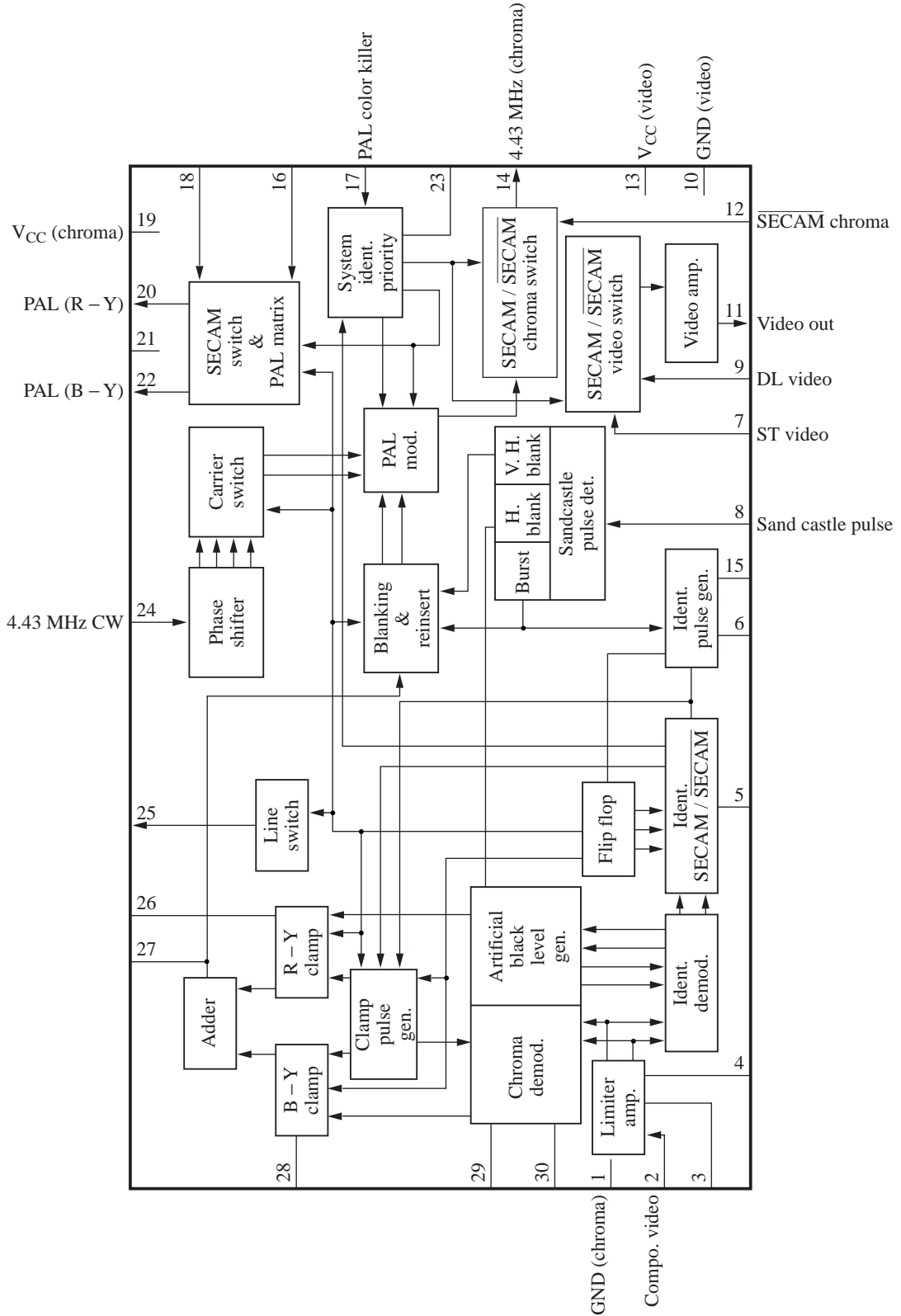

■ Pin Descriptions

Pin No.	Description	Pin No.	Description
1	GND (chroma-system)	17	PAL color killer voltage input
2	SECAM chroma input	18	Delay signal input
3	Limiter feedback	19	V _{CC} (chroma system)
4	Limiter feedback	20	R–Y signal output
5	System discrimination holding capacitor	21	Reference bias power supply
6	Identification pulse fall setting	22	B–Y signal output
7	Not SECAM video signal input	23	System identification voltage output combined with system forcing switch
8	Sand castle pulse input		
9	SECAM video signal input	24	4.43 MHz CW input
10	GND (video system)	25	Line switch output
11	Video signal output	26	R–Y clamp capacitance
12	Not SECAM chroma signal input	27	De-emphasis circuit
13	V _{CC} (video system)	28	B–Y clamp capacitance
14	PAL chroma signal output	29	Discriminator
15	Identification pulse rise setting	30	Discriminator
16	Direct signal input		

■ Absolute Maximum Ratings

Parameter	Symbol	Rating	Unit
Supply voltage	V _{CC}	6.0	V
Supply current	I _{CC}	100	mA
Power dissipation *2	P _D	600	mW
Operating ambient temperature *1	T _{opr}	–20 to +70	°C
Storage temperature *1	T _{stg}	–55 to +150	°C

Note) *1 : Except for the operating ambient temperature and storage temperature, all ratings are for T_a = 25°C.

*2 : T_a = 70°C, Independent IC without a heat sink

■ Recommended Operating Range

Parameter	Symbol	Range	Unit
Supply voltage	V_{CC}	4.5 to 5.5	V
Pin voltage	V_{2-1}	0 to V_{19-1}	V
Pin voltage	V_{3-1}	0 to V_{19-1}	V
Pin voltage	V_{4-1}	0 to V_{19-1}	V
Pin voltage	V_{5-1}	0 to V_{19-1}	V
Pin voltage	V_{6-1}	0 to V_{19-1}	V
Pin voltage	V_{7-1}	0 to V_{19-1}	V
Pin voltage	V_{8-1}	0 to V_{19-1}	V
Pin voltage	V_{9-1}	0 to V_{19-1}	V
Pin voltage	V_{11-1}	0 to 4.5	V
Pin voltage	V_{12-1}	0 to V_{19-1}	V
Pin voltage	V_{14-1}	0 to 4.0	V
Pin voltage	V_{15-1}	0 to V_{19-1}	V
Pin voltage	V_{16-1}	0 to V_{19-1}	V
Pin voltage	V_{17-1}	0 to V_{19-1}	V
Pin voltage	V_{18-1}	0 to V_{19-1}	V
Pin voltage	V_{20-1}	0 to V_{19-1}	V
Pin voltage	V_{22-1}	0 to V_{19-1}	V
Pin voltage	V_{23-1}	0 to V_{19-1}	V
Pin voltage	V_{24-1}	0 to V_{19-1}	V
Pin voltage	V_{25-1}	0 to V_{19-1}	V
Pin voltage	V_{26-1}	0 to V_{19-1}	V
Pin voltage	V_{27-1}	0 to 4.0	V
Pin voltage	V_{28-1}	0 to V_{19-1}	V
Pin voltage	V_{29-1}	0 to V_{19-1}	V
Pin voltage	V_{30-1}	0 to V_{19-1}	V
Pin voltage	$ V_{7-9} $	0 to 3	V
Pin voltage	$ V_{16-18} $	0 to 4.5	V
Pin current	I_5	-1 to +1	mA
Pin current	I_6	0 to +2	mA
Pin current	I_{11}	-10 to 0	mA
Pin current	I_{14}	-4 to 0	mA
Pin current	I_{15}	0 to +2	mA
Pin current	I_{20}	-2 to 0	mA
Pin current	I_{22}	-2 to 0	mA

■ Electrical Characteristics at $T_a = 25^\circ\text{C}$

Parameter	Symbol	Conditions	Min	Typ	Max	Unit
1. DC						
Circuit current	I_{CC1}	Pin 13: 5.0 V, pin 13: 5.0 V	40	58	76	mA
2. AC						
Chroma block						
SECAM input signal limiting range	$V_{30(\text{lim})}$	Pin 30 output, when pin 2 input is 4.328 MHz CW of 20 mV[p-p] to 400 mV[p-p]	-1	0	+1	dB
Limiter amplifier gain	$G_{V30(\text{lim})}$	Pin 30 output, when pin 2 input is 4.328 MHz CW of 2 mV[p-p]	18	28	38	dB
SECAM demodulation output signal (B-Y)	$E_{27(B-Y)}$	Peak to peak voltage of D_B at pin 27 for SECAM color bar chroma of 200 mV[p-p] input to pin 2	159	227	295	mV[p-p]
SECAM demodulation output signal (R-Y)	$E_{27(R-Y)}$	Peak to peak voltage of D_R at pin 27 for SECAM color bar chroma of 200 mV[p-p] input to pin 2	225	321	417	mV[p-p]
SECAM demodulation output ratio (R-Y/ B-Y)	$E_{27(R-Y/B-Y)}$	Peak to peak voltage of D_R vs. D_B at pin 27 for SECAM color bar chroma of 200 mV[p-p] input to pin 2	0.99	1.41	1.84	—
SECAM modulation gain	G_{S27-14}	Peak to peak voltage of D_R at pin 27 vs. D_R red at pin 14 for SECAM color bar chroma of 200 mV[p-p] input to pin 2	0.5	1.0	1.5	Times
SECAM modulation output ratio (R-Y/ burst)	$V_{14(R-Y/\text{burst})}$	At pin 14, D_R red vs. D_R burst for SECAM color bar chroma of 200 mV[p-p] input to pin 2	2.34	3.35	4.36	—
SECAM modulation output ratio (R-Y/ B-Y)	$V_{14(R-Y/B-Y)}$	At pin 14, D_R red vs. D_R blue for SECAM color bar chroma of 200 mV[p-p] input to pin 2	0.99	1.41	1.84	—
PAL chroma amp gain	G_{P12-14}	Pin 14 chroma output for PAL chroma 330 mV[p-p] input to pin 12	0.7	1.0	1.3	Times
Video block						
Frequency characteristics (SECAM)	$F_{11\text{SECAM}}$	Pin 11 cutoff frequency for CW 0.3 V[p-p] input to pin 9	10	—	—	MHz
Frequency characteristics (PAL)	$F_{11\text{PAL}}$	Pin 11 cutoff frequency for CW 0.3 V[p-p] input to pin 7	10	—	—	MHz
Gain (SECAM)	$G_{11\text{SECAM}}$	10 kHz CW output gain at pin 11 for 10 kHz CW 0.3 V[p-p] input to pin 9	4	7	10	dB
Gain (PAL)	$G_{11\text{PAL}}$	10 kHz CW output gain at pin 11 for 10 kHz CW 0.3 V[p-p] input to pin 7	4	7	10	dB

■ Electrical Characteristics at $T_a = 25^\circ\text{C}$ (continued)

Parameter	Symbol	Conditions	Min	Typ	Max	Unit
2. AC (continued)						
SECAM switch PAL matrix block						
SECAM switching gain (ST, B–Y)	G_{S16-22}	PAL chroma output at pin 22 for PAL chroma 660 mV[p-p] at pin 16	0.7	1	1.3	Times
SECAM switching gain (ST, R–Y)	G_{S16-20}	PAL chroma output at pin 20 for PAL chroma 660 mV[p-p] at pin 16	0.7	1	1.3	Times
SECAM switching gain (DL, B–Y)	G_{S18-22}	PAL chroma output at pin 22 for PAL chroma 660 mV[p-p] at pin 18	0.7	1	1.3	Times
SECAM switching gain (DL, R–Y)	G_{S18-20}	PAL chroma output at pin 20 for PAL chroma 660 mV[p-p] at pin 18	0.7	1	1.3	Times
PAL matrix gain (ST, +)	G_{P16-22}	PAL chroma output at pin 22 for PAL chroma 660 mV[p-p] at pin 16	0.35	0.5	0.65	Times
PAL matrix gain (DL, +)	G_{P18-22}	PAL chroma output at pin 22 for PAL chroma 660 mV[p-p] at pin 18	0.35	0.5	0.65	Times
PAL matrix gain (ST, –)	G_{P16-20}	PAL chroma output at pin 20 for PAL chroma 660 mV[p-p] at pin 16	0.35	0.5	0.65	Times
PAL matrix gain (DL, –)	G_{P18-20}	PAL chroma output at pin 20 for PAL chroma 660 mV[p-p] at pin 18	0.35	0.5	0.65	Times
Discrimination block						
SECAM killer tolerance	E_K	Killer on level, when SECAM color bar chroma 200 mV[p-p] at pin 2 is referred as 0 dB	–48	–42	–36	dB
Killer detection voltage SECAM color	$V_{23\text{SECAM}}$	Pin 23 voltage for SECAM color bar chroma of –34 dB at pin 2	0	0.25	0.5	V
Killer detection voltage SECAM off	$V_{23\text{OFF}}$	Pin 23 voltage for SECAM color bar chroma of –50 dB at pin 2	0.7	3.0	5.0	V
Ident. detection voltage PAL	$V_{23\text{PAL}}$	Pin 23 voltage for PAL color bar chroma burst of 150 mV[p-p] at pin 2	0.7	3.0	5.0	V
System switch block						
System discrimination output voltage ($\overline{\text{SECAM}}$)	$V_{23\text{SOUT}}$	System discrimination output at pin 23 for PAL color bar chroma burst of 150 mV[p-p] at pin 2	0.7	3.0	5.0	V
System discrimination output voltage (SECAM)	$V_{23\text{SOUT}}$	System discrimination output at pin 23 for SECAM color bar chroma of 0 dB at pin 2	0	0.25	0.5	V

■ Electrical Characteristics at $T_a = 25^\circ\text{C}$ (continued)

• Design reference data

Note) The characteristics listed below are theoretical values based on the IC design and are not guaranteed.

Parameter	Symbol	Conditions	Min	Typ	Max	Unit
1. AC						
Chroma block						
PAL chroma input signal voltage	$V_{12(\text{PAL})}$	Pin 12: PAL chroma input signal	—	330	660	mV[p-p]
SECAM demodulation linearity	$LE_{27(\text{R-Y})}$	Pin 2: 4.406 MHz ± 0.28 MHz Output linearity at pin 27	80	90	100	%
SECAM modulation linearity	$LV_{14(\text{R-Y})}$	Pin 2: 4.406 MHz ± 0.28 MHz Output linearity at pin 14	80	90	100	%
SECAM modulation output phase difference	$\Delta\Psi_{14}$	At pin 14, D_B vs. D_R output phase difference for SECAM color bar chroma of 200 mV[p-p] input to pin 2	80	90	100	$^\circ$
SECAM modulation output signal (B-Y)	$V_{14(\text{B-Y})}$	D_B blue at pin 14 for SECAM color bar chroma of 200 mV[p-p] input to pin 2	136	227	318	mV[p-p]
SECAM modulation output signal (R-Y)	$V_{14(\text{R-Y})}$	D_R red at pin 14 for SECAM color bar chroma of 200 mV[p-p] input to pin 2	192	321	450	mV[p-p]
SECAM modulation output signal (burst)	$V_{14(\text{Burst})}$	D_R burst at pin 14 for SECAM color bar chroma of 200 mV[p-p] input to pin 2	57	96	135	mV[p-p]
Video block						
Video input signal voltage (SECAM)	$V_{9\text{SECAM}}$	Pin 9: SECAM video input	—	0.3	0.6	V[p-p]
Video input signal voltage (PAL)	$V_{9\text{PAL}}$	Pin 7: PAL video input	—	0.3	0.6	V[p-p]
SECAM switch PAL matrix block						
Direct input signal voltage	V_{16}	Pin 16: chroma input	—	660	1 320	mV[p-p]
Delay input signal voltage	V_{18}	Pin 18: chroma input	—	660	1 320	mV[p-p]
SECAM amplification degree ratio (ST/DL, B-Y)	$D_{S\text{B-Y}}$	PAL chroma input to pin 16 or pin 18 PAL chroma output ratio at pin 22	0.8	1.0	1.2	—
SECAM amplification degree ratio (ST/DL, R-Y)	$D_{S\text{R-Y}}$	PAL chroma input to pin 16 or pin 18 PAL chroma output ratio at pin 22	0.8	1.0	1.2	—
PAL amplification degree ratio (ST, B-Y/R-Y)	DP_{ST}	Pin 16: PAL chroma input Ratio of PAL chroma output at pin 22 to at pin 20	0.8	1.0	1.2	—
PAL amplification degree ratio (DL, B-Y/R-Y)	DP_{DL}	Pin 18: PAL chroma input Ratio of PAL chroma output at pin 22 to at pin 20	0.8	1.0	1.2	—
SECAM switch output phase difference (B-Y)	$\Delta\Psi_{\text{B-Y}}$	Pin 22 output phase difference, when PAL chroma is inputted to pin 16, pin 18	-10	0	+10	$^\circ$
SECAM switch output phase difference (R-Y)	$\Delta\Psi_{\text{R-Y}}$	Pin 20 output phase difference, when PAL chroma is inputted to pin 16, pin 18	170	180	190	$^\circ$
Carrier block						
4.43 MHz input signal voltage	$V_{24\text{IN}}$	Pin 24 4.43 MHz CW input	—	0.3	0.5	V[p-p]

■ Electrical Characteristics at $T_a = 25^\circ\text{C}$ (continued)

• Design reference data

Note) The characteristics listed below are theoretical values based on the IC design and are not guaranteed.

Parameter	Symbol	Conditions	Min	Typ	Max	Unit
1. AC (continued)						
System switch block						
PAL color killer input threshold voltage (color)	$V_{17\text{Color}}$	Input voltage at pin 17	0.5	3.0	5.0	V
PAL color killer input threshold voltage (killer)	$V_{17\text{Color}}$	Input voltage at pin 17	0	0.25	0.5	V
System-forcing switch input threshold voltage (SECAM)	$V_{23\text{SIN}}$	Input voltage at pin 23	0.5	3.0	5.0	V
System-forcing switch input threshold voltage (SECAM)	$V_{23\text{SIN}}$	Input voltage at pin 23	0	0.25	0.5	V
Pulse input block						
BGP detection voltage	V_{THBGP}	Pin 8: sand castle pulse	3.25	3.5	3.75	V
H pulse detection voltage	V_{THHP}	Pin 8: sand castle pulse input	1.8	2.2	2.6	V
BLK pulse detection voltage	V_{THBLKP}	Pin 8: sand castle pulse input	0.7	0.95	1.2	V
Burst phase width adjusting block						
Front edge threshold level	V_{TH6}	Threshold level at pin 6	1.0	1.25	1.5	V
Rear edge threshold level	V_{TH15}	Threshold level at pin 15	1.0	1.25	1.5	V
Flip-flop block						
De-emphasis switch output (B-Y)	$V_{25\text{B-Y}}$	Output voltage at pin 25	0	0.25	0.5	V
De-emphasis switch output (R-Y)	$V_{25\text{R-Y}}$	Output voltage at pin 25	0.5	3.0	5.0	V

■ Application Circuit Example

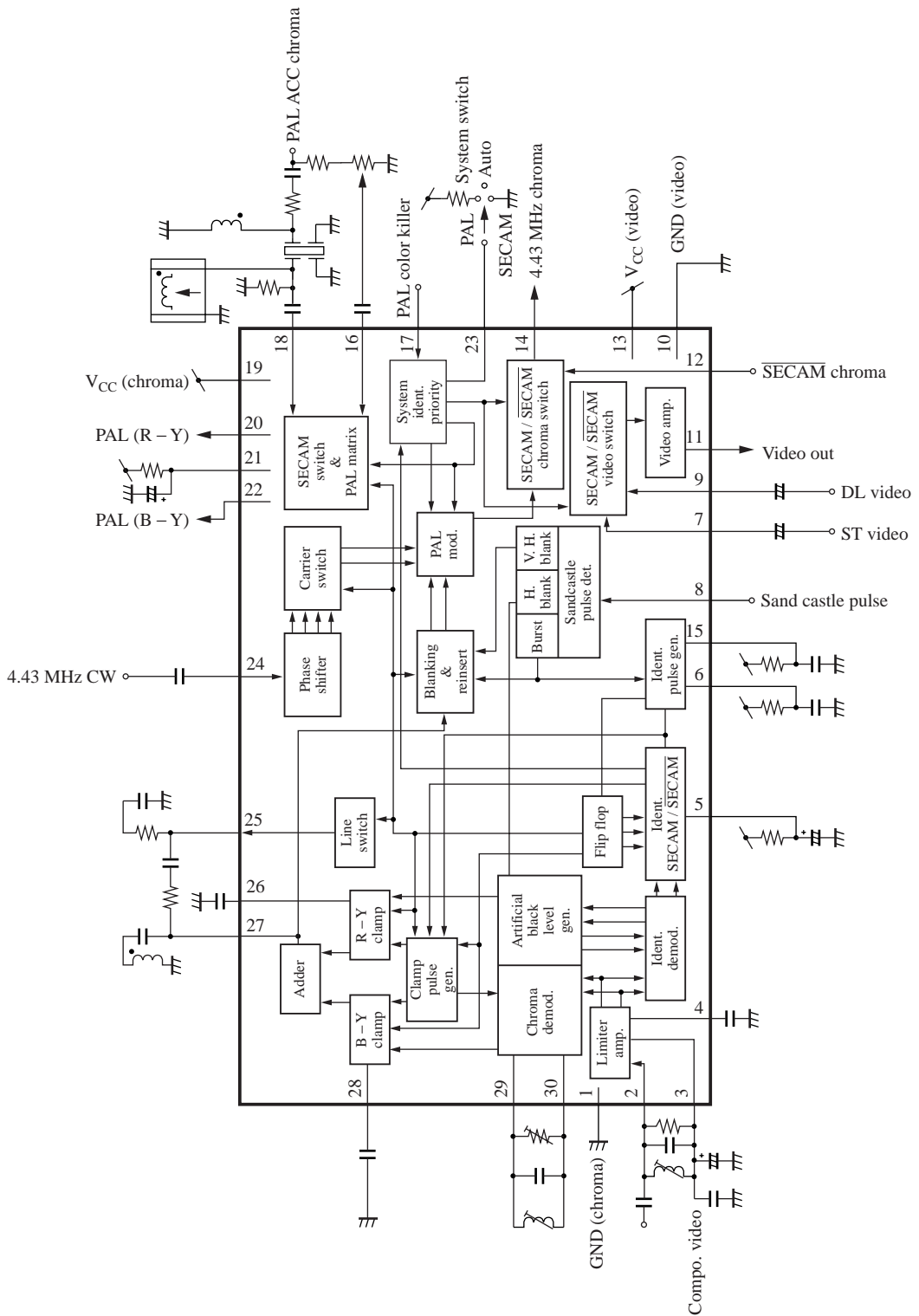



LittleDiode supplies new, hard to find or obsolete electronic components and semiconductors all over the world.

With over two million different components listed you are sure to find the part you need.

Feel free to visit us today at our online store:

LittleDiode.com

Looking forward to providing you with the best possible service.