

## CHOICE OF PROTECTION IN AUTOMOTIVE APPLICATIONS(CLASSICAL TOPOLOGY)

A. Bremond

### 1. INTRODUCTION

This paper describes a protection schematic based on discrete components, together with a general method of choosing the components to

suppress the surge effects on automotive modules.

**Figure 1** : General Protection Topology

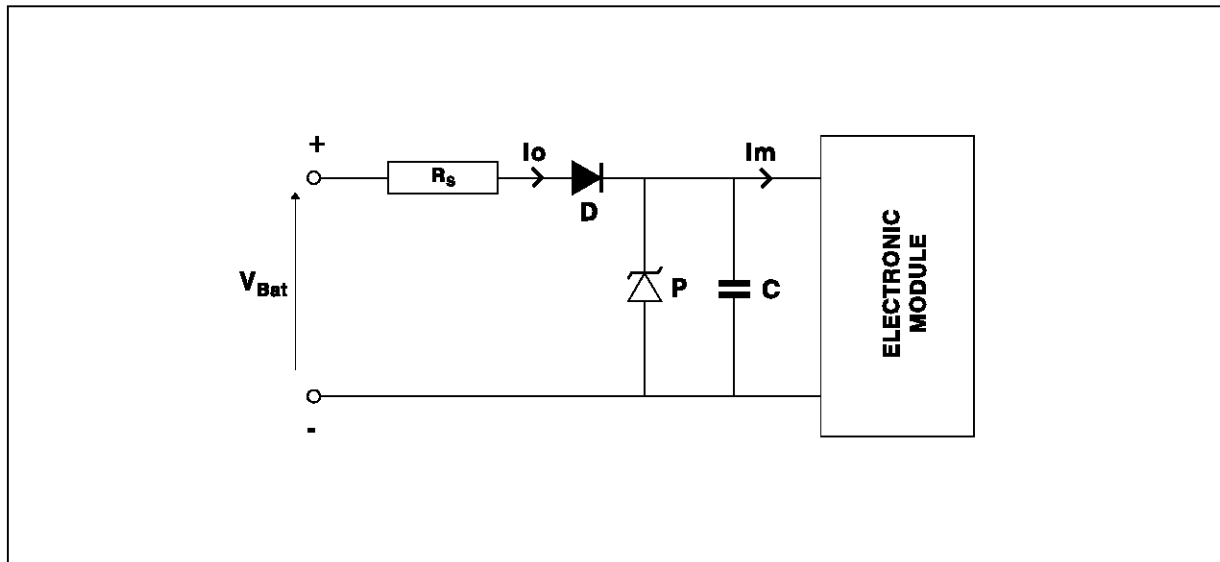

### 2. GENERAL PROTECTION SCHEMATIC :

#### 2.a Positive impulsive overvoltages :

This type of overvoltage is clamped by the protection component  $P$  at maximum voltage  $V_{CL}$ . Resistance  $R_s$  limits the dissipated energy in the protection component without compromising the clamping function.

#### 2.b Negative impulsive overvoltages :

There are two ways to limit these :

- Without diode  $D$  : the protection component operates as a rectifier diode and clamps the voltage at the unit terminals to approximately 1 V.

- With diode  $D$  : the diode is reverse-biased and therefore protects the unit.

One important thing to take into account is the peak reverse voltage limit of  $D$ .  $V_{RRM} = 400V$  seems a good compromise (see curve N° 6 of the ISO/TC22 standard).

#### 2.c Positive continuous overvoltages :

During this phase, the protection component must be in the stand-by phase (very low current passing through the component).

#### 2.d Negative continuous overvoltages :

This protection is achieved by diode  $D$  which is reverse -biased.

#### 2.e Impulsive voltage drop :

During this phase, the unit is fed by capacitor  $C$  while diode  $D$  prevents  $C$  from discharging into the battery circuit.

## APPLICATION NOTE

### 3. THE CHOICE OF COMPONENTS :

#### 3.a Diode (D)

The following parameters will constitute the selection criteria :

- The average current used by the electronic module.
- The maximum repetitive peak reverse voltage  $V_{RRM}$
- The maximum ambient temperature  $T_{amb}$ .

The following inequality must apply in all cases :

$$T_{amb} + R_{th} P < T_j \text{ max}$$

where

$$P = V_{TO} I_F (AV) + r_d I_F^2 (R_{MS})$$

$R_{th}$  = thermal resistance (Junction - ambient) for the device and mounting in use.

#### 3.b Resistance ( $R_S$ )

Its presence allows a "size" (and thus cost) reduction of the protection component.

Its value is a function of the following elements :

$V_{bat \text{ min}}$  : lowest battery voltage which is specified in the technical note issued by the manufacturer.

$V_{CC \text{ min}}$  : minimum voltage needed for the electronic unit in operation.

$I_{CC \text{ max}}$  : maximum supply current of the electronic module.

The maximum value of  $R_S$  will be :

$$R_S \text{ max} = (V_{bat \text{ min}} - V_{CC \text{ min}}) / I_{CC \text{ max}}$$

#### 3.c Capacitor (C)

Its role is to make sure that the voltage at the terminals of the electronic unit is greater than or equal to  $V_{CC \text{ min}}$  while the starter circuit is active.

Its value depends on :

$V_{bat}$  : voltage across the battery before the disturbance

$V_{CC \text{ min}}$  : see par. 5.b

$T$  : length of the disturbance (130 ms: see application note 4.1, paragraph III.4)

The minimum value of C will be :

$$C_{min} = (130 * 10^{-3} / R_{eq}) / \ln (V_{CC \text{ min}} / V_{bat})$$

with  $R_{eq}$  = equivalent resistance of the electronic unit

$$R_{eq} = V_{CC \text{ min}} / I_{CC \text{ max}}$$

#### 3.d Protection component (P)

- How it works :

**Figure 2** : Transil Behaviour

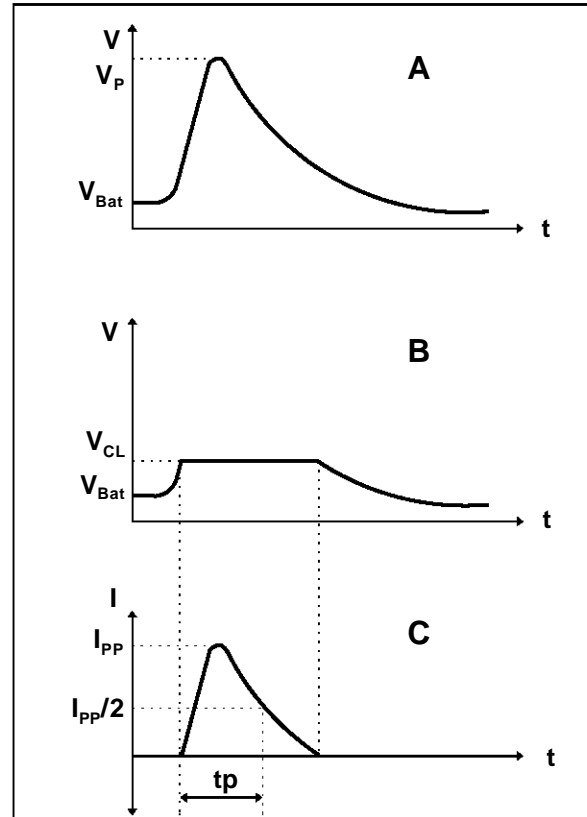

A : Disturbance

B : Voltage across the protection device

C : Current through the protection device

The role of the protection device is to suppress the destructive effects of the surge (Fig.2a), the most aggressive being the load dump impulse.

To achieve this, the TRANSIL clamps the spike at a maximum value  $V_{CL}$  (Fig.2b). A surge current flows through the suppressor during this phase (Fig.2c).

#### 4. THE CHOICE OF THE PROTECTION DEVICE

##### 4.a Parameters to take into account

To choose the TRANSIL we have to know the surge parameters and the application requirements.

- Surge parameters

The surge is defined by the peak value  $I_p$  and the duration  $t_p$  of the current wave flowing through the protection device during the clamping.

As shown in the ISO/TC22 standard the most energetic impulsive disturbance is the load dump surge. Most car manufacturers recommend the SCHAFFNER NSG 506 generator to synthesise this wave. See fig.3.

Figure3 : Equivalent circuit of Schaffner generator

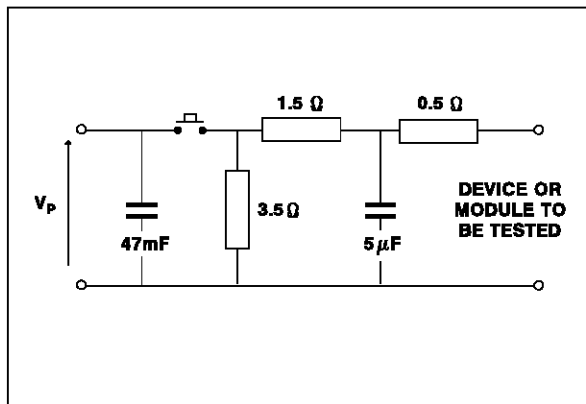

This circuit allows us to determine the parameters of the current wave seen by the TRANSIL.

The peak current  $I_P$  is equal to :

$$I_P = (V_P - V_{CL}) / (R_G + R_S)$$

Where

$$V_P = \text{Peak voltage of the surge (+ 80V)}$$

$$V_{CL} = \text{Clamping voltage of the transil}$$

$R_G$  = Series resistance of the generator (2 Ohms)

$R_S$  = Series resistance of the module to be protected (see chapter 3.b)

For example with  $V_P = 80V$ ,  $V_{CL} = 40 V$  and  $R_S = 0 \text{ Ohm}$ , we have  $I_P = 20A$

Figure 4 : Current pulse duration versus  $V_P$  and  $V_{CL}$

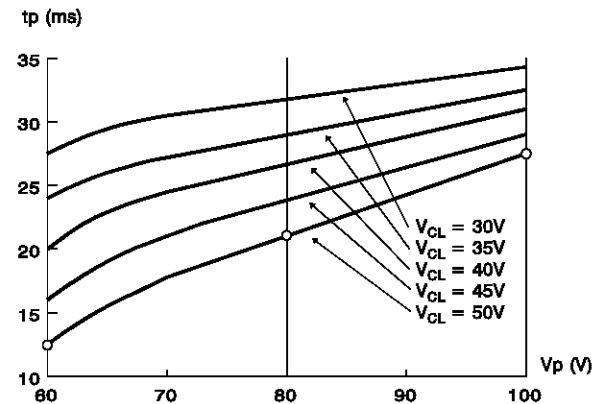

The curves of figure 4 give the duration  $t_p$  of the current wave in the TRANSIL during clamping. This parameter depends on the peak voltage  $V_P$  of the surge and on the clamping voltage  $V_{CL}$  of the protection device. For example with  $V_P = 80V$  and  $V_{CL} = 40V$ ,  $t_p = 27.5 \text{ ms}$ .

- Application requirements

Three values are necessary :

- The maximum operating voltage, which is the greatest battery potential. Often the car's electrical equipment has to withstand two battery voltages (due to starting aids: see ISO/TC22 standard). These parameters define the minimum stand off voltage  $V_{RM}$  of the TRANSIL.

- The minimum destructive voltage, which is the voltage value over which the device will be destroyed. This limit determines the maximum clamping voltage  $V_{CL}$  of the protection device.

- The maximum ambient temperature  $T_{amb}$  that would decrease the power dissipation capability of the TRANSIL.

## APPLICATION NOTE

### 4.b Choice of the protection device

The choice of component is made with the help of the parameters  $t_P$ ,  $P_P$  in the curve  $P_P = f(t_P)$  from the "PROTECTION DEVICES" data book.

**Figure 5** : Peak pulse power versus exponential pulse duration (1.5KE,  $10V < V_{BR} < 250 V$ )

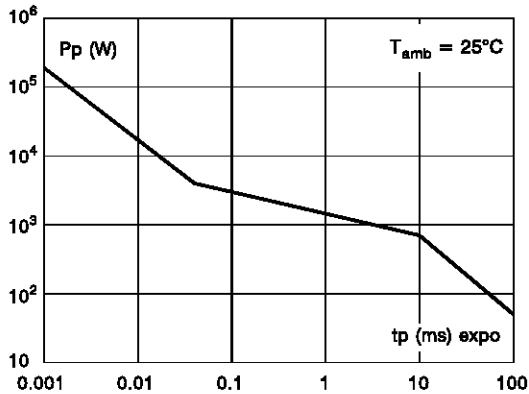

If the operating point defined by  $t_P$  and  $P_P = V_{CL} * I_P$  is on or below the curve, the TRANSIL can operate in the application at 25°C of ambient temperature.

### 4.c The ambient temperature effect :

Component characteristics are given at an ambient temperature of 25°C (die temperature before clamping action). The following chart shows the effect of junction temperature on the power suppression capability.

**Figure 6** : Allowable power dissipation versus junction temperature

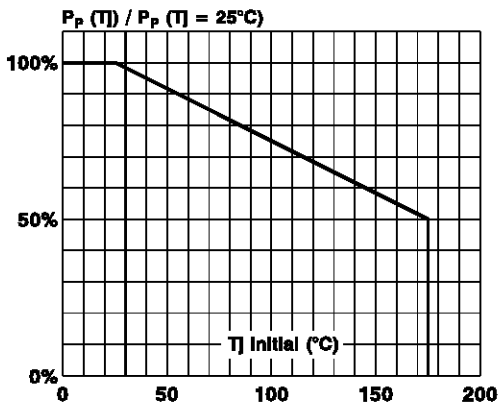

This curve gives the derating to be applied to the peak power capability of the protection device according to junction temperature.

The second temperature effect is the shift of  $V_{BR}$ .

$$V_{BR}(\text{at } T) = V_{BR}(\text{at } 25^\circ\text{C}) * (1 + \alpha_T (T-25))$$

Where  $\alpha_T$  is the temperature coefficient of  $V_{BR}$ .

### 4.d Calculation of clamping voltage $V_{CL}$

The clamping voltage  $V_{CL}$  can be estimated as follows :

$$V_{CL} = V_{BR \text{ max}} + (R_d I_P)$$

Where  $R_d$  is the dynamic resistance of the TRANSIL

**Table 1** - Typical  $R_d$  for wave of  $t_P = 30 \text{ ms}$  at 25°C

	BZW04 P23	P6KE 30P	1.5KE 30P	BZW50 -22	LDP24AS
$R_d$ typ ( $\Omega$ )	1.2	0.75	0.35	0.15	0.12

## 5 - EXAMPLE :

### A / Disturbances

The load dump is the most aggressive

### B / Battery voltage

The electronic unit will have to function with a battery voltage of 11 V.

### C / Ambient temperature

$$T_{amb} = 85^\circ\text{C}$$

### D/ Electrical characteristics of the module

**Table 2** - Module characteristics

PARAMETERS	$V_{CC}$	$I_{CC}$
DESCRIPTION	Supply voltage	Supply current
MIN	8	-
TYP	12	400
MAX	32	600
UNIT	Volts	mA

**E / Analysis**

**E/1** Calculation of  $R_S$  max

$$R_S \text{ max} = (V_{\text{bat}} - V_{\text{CC min}}) / I_{\text{CC max}}$$

$$R_S \text{ max} = (11-8) / 0.6 = 5 \text{ Ohms}$$

**E/2** Diagram

**Figure 7** : Application Diagram

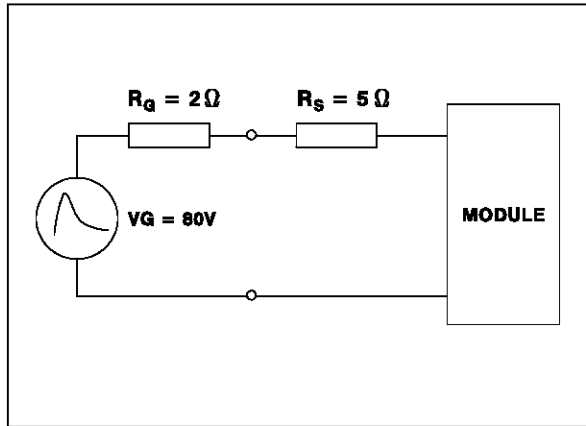

**E/3** Peak current

$$I_{PP} = (V_G - V_{CL}) / (R_G + R_S) = (80 - 32) / 7 = 6.9A$$

**E/4** Peak power

$$P_P = V_{CL} * I_{PP} = 32 * 6.9 = 221 \text{ W}$$

**E/5** Conduction time

$$t_P = 30 \text{ ms}$$

**E/6** Choice of the TRANSIL

**Table 3** - Transil characteristics

TYPE	POWER CAPABILITY ( $t_P = 30 \text{ ms}$ )	
	at 25°C	at 85°C
BZW04	60 W	45 W
P6KE	80 W	64 W
1.5KE	200 W	160 W
BZW50	700 W	525 W
LDP24A	1980 W	1800 W

**E/7** Conclusion

Diode BZW50-22 is an efficient protection device within the 85°C temperature range, and the  $V_{CL}$  max is given as follows :

$$V_{BR} (85^\circ\text{C}) = V_{BR} (25^\circ\text{C}) * (1 + \alpha_T(85-25))$$

$$= 29.8 * (1 + 9.6 * 10^{-4} * 60)$$

$$= 31.5V$$

$$V_{CL} (85^\circ\text{C}) = V_{BR} (85^\circ\text{C}) + R_d I_P$$

$$= 31.5 + (0.15 * 6.9)$$

$$= 32.5 \text{ V}$$

Information furnished is believed to be accurate and reliable. However, SGS-THOMSON Microelectronics assumes no responsibility for the consequences of use of such information nor for any infringement of patents or other rights of third parties which may result from its use. No license is granted by implication or otherwise under any patent or patent rights of SGS-THOMSON Microelectronics. Specifications mentioned in this publication are subject to change without notice. This publication supersedes and replaces all information previously supplied.

SGS-THOMSON Microelectronics products are not authorized for use as critical components in life support devices or systems without express written approval of SGS-THOMSON Microelectronics.

© 1995 SGS-THOMSON Microelectronics - Printed in Italy - All rights reserved.

SGS-THOMSON Microelectronics GROUP OF COMPANIES

Australia - Brazil - France - Germany - Hong Kong - Italy - Japan - Korea - Malaysia - Malta - Morocco  
The Netherlands - Singapore - Spain - Sweden - Switzerland - Taiwan - Thailand - United Kingdom - U.S.A.



LittleDiode supplies new, hard to find or obsolete electronic components and semiconductors all over the world.

With over two million different components listed you are sure to find the part you need.

Feel free to visit us today at our online store:

[LittleDiode.com](http://LittleDiode.com)

Looking forward to providing you with the best possible service.