

AN5395FBP

Contour correction IC for HDTV

■ Overview

The AN5395FBP is a contour correction IC which enables correction band changeover for base band HDTV, MUSE, progressive NTSC TV.

■ Features

- Contour correction for HDTV
- Contour correction for progressive TV

■ Applications

- HDTV

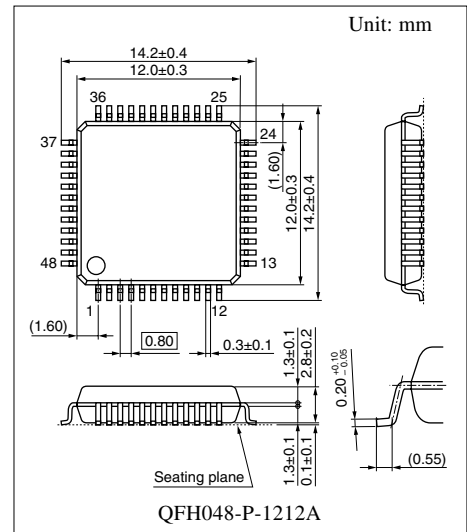

Note) The package of this product will be changed to lead-free type (QFH048-P-1212C). See the new package dimensions section later of this datasheet.

■ Pin Descriptions

Pin No.	Description	Pin No.	Description
1	P_R input	25	Sharpness mute control
2	VM pre-amp. gain control	26	Sharpness control
3	VM pre-amp. input	27	Y output
4	VM pre-amp. output	28	Contour block gain control
5	Child picture Y_S input	29	Contour block bias
6	Y_S input	30	Secondary differentiating input
7	VM limiter amp. input	31	Detail gain control
8	VM limiter amp. gain control	32	Primary differentiating output after correction
9	VM limiter amp. output	33	Detail coring control
10	Child picture amp. output	34	Detail coring bias
11	Child picture amp. gain control	35	Differentiating signal bias 1
12	Child picture amp. input	36	Contour block and detail separation level control
13	P_R output		
14	N.C.	37	Differentiating signal bias 2
15	P_B output	38	Detail limiter output
16	DSC large signal gain control	39	Y delay line changeover switch 1
17	Primary differentiating input before correction	40	Y delay line changeover switch 2
18	N.C.	41	N.C.
19	V_{CC}	42	GND
20	DSC detection output	43	Clamp pulse input
21	DSC small signal gain control	44	N.C.
22	DSC input	45	Y input
23	DSC bias	46	C delay line changeover switch 1
24	Primary differentiating output before correction	47	P_B input
		48	C delay line changeover switch 2

■ Absolute Maximum Ratings

Parameter	Symbol	Rating	Unit
Supply voltage	V_{CC}	10.0	V
Supply current	I_{CC}	100	mA
Power dissipation *2	P_D	650	mW
Operating ambient temperature *1	T_{opr}	-20 to +70	°C
Storage temperature *1	T_{stg}	-55 to +150	°C

Note) *1: Except for the operating ambient temperature and storage temperature, all ratings are for $T_a = 25^\circ\text{C}$.

*2: The power dissipation shown is the value for $T_a = 70^\circ\text{C}$.

■ Recommended Operating Range

Parameter	Symbol	Range	Unit
Supply voltage	V_{CC}	8.1 to 9.9	V

■ Electrical Characteristics at $T_a = 25^\circ\text{C}$

Parameter	Symbol	Conditions	Min	Typ	Max	Unit
Circuit current	I_{CC}		50	70	90	mA
Circuit voltage	V_1		4.50	5.63	6.76	V
Circuit voltage	V_2		4.40	5.86	7.33	V
Circuit voltage	V_3		2.04	2.55	3.06	V
Circuit voltage	V_4		4.64	5.80	6.96	V
Circuit voltage	V_7		2.04	2.55	3.06	V
Circuit voltage	V_9		4.60	5.75	6.90	V
Circuit voltage	V_{10}		4.64	5.80	6.96	V
Circuit voltage	V_{11}		4.40	5.86	7.33	V
Circuit voltage	V_{12}		2.04	2.55	3.06	V
Circuit voltage	V_{13}		3.74	4.67	5.60	V
Circuit voltage	V_{15}		3.74	4.67	5.60	V
Circuit voltage	V_{16}		3.80	4.75	5.70	V
Circuit voltage	V_{17}		4.50	5.63	6.76	V
Circuit voltage	V_{21}		3.40	4.25	5.10	V
Circuit voltage	V_{22}		2.12	2.65	3.18	V
Circuit voltage	V_{24}		3.70	4.62	5.54	V
Circuit voltage	V_{27}		3.44	4.30	5.16	V
Circuit voltage	V_{29}		2.93	3.66	4.39	V
Circuit voltage	V_{30}		1.96	2.45	2.94	V
Circuit voltage	V_{31}		2.71	3.61	4.51	V
Circuit voltage	V_{32}		2.12	2.65	3.18	V
Circuit voltage	V_{33}		4.27	5.34	6.41	V
Circuit voltage	V_{34}		4.55	5.69	6.83	V
Circuit voltage	V_{35}		2.65	3.31	3.97	V
Circuit voltage	V_{36}		2.40	3.00	3.60	V
Circuit voltage	V_{37}		2.65	3.31	3.97	V
Circuit voltage	V_{38}		6.25	7.81	9.37	V
Circuit voltage	V_{39}		1.80	2.90	4.00	V
Circuit voltage	V_{40}		1.80	2.90	4.00	V
Circuit voltage	V_{45}		4.50	5.63	6.76	V

■ Electrical Characteristics at $T_a = 25^\circ\text{C}$ (continued)

Parameter	Symbol	Conditions	Min	Typ	Max	Unit
Circuit voltage	V_{46}		1.80	2.90	4.00	V
Circuit voltage	V_{47}		4.50	5.63	6.76	V
Circuit voltage	V_{48}		1.80	2.90	4.00	V
Circuit current	I_{23}		-1.50	0.00	1.50	μA
Circuit current	I_{43}		-1.50	0.00	1.50	μA
C-D.L block						
P_B output dynamic range	V_{DR15}	$V_{IN47} = 5.18 \text{ V to } 6.08 \text{ V}$	0.9	1.2	1.5	V[p-p]
P_R output dynamic range	V_{DR13}	$V_{IN1} = 5.18 \text{ V to } 6.08 \text{ V}$	0.9	1.2	1.5	V[p-p]
Delay time changeover switch C1 threshold level	V_{TH46}		0.9	1.5	2.1	V
Delay time changeover switch C2 threshold level	V_{TH48}		0.9	1.5	2.1	V
P_B signal output gain (HD)	$G_{A(PB,1)}$	$V_{A(PB,1)} / 0.1 \text{ V[p-p]}$	1.81	2.92	3.91	dB
P_B signal output gain (MUSE)	$G_{B(PB,1)}$	$V_{B(PB,1)} / 0.1 \text{ V[p-p]}$	1.81	2.92	3.91	dB
P_B signal output gain (NTSC1)	$G_{C(PB,1)}$	$V_{C(PB,1)} / 0.1 \text{ V[p-p]}$	1.81	2.92	3.91	dB
P_B signal output gain (NTSC2)	$G_{D(PB,1)}$	$V_{D(PB,1)} / 0.1 \text{ V[p-p]}$	1.81	2.92	3.91	dB
P_B signal output gain difference (MUSE/HD)	$G_{B/A(PB)}$	$V_{B(PB,1)} / V_{A(PB,1)}$	-1	0	1	dB
P_B signal output gain difference (NTSC1/HD)	$G_{C/A(PB)}$	$V_{C(PB,1)} / V_{A(PB,1)}$	-1	0	1	dB
P_B signal output gain difference (NTSC2/HD)	$G_{D/A(PB)}$	$V_{D(PB,1)} / V_{A(PB,1)}$	-1	0	1	dB
P_R signal output gain (HD)	$G_{A(PR,1)}$	$V_{A(PR,1)} / 0.1 \text{ V[p-p]}$	1.81	2.92	3.91	dB
P_R signal output gain (MUSE)	$G_{B(PR,1)}$	$V_{B(PR,1)} / 0.1 \text{ V[p-p]}$	1.81	2.92	3.91	dB
P_R signal output gain (NTSC1)	$G_{C(PR,1)}$	$V_{C(PR,1)} / 0.1 \text{ V[p-p]}$	1.81	2.92	3.91	dB
P_R signal output gain (NTSC2)	$G_{D(PR,1)}$	$V_{D(PR,1)} / 0.1 \text{ V[p-p]}$	1.81	2.92	3.91	dB
P_R signal output gain difference (MUSE/HD)	$G_{B/A(PR)}$	$V_{B(PR,1)} / V_{A(PR,1)}$	-1	0	1	dB
P_R signal output gain difference (NTSC1/HD)	$G_{C/A(PR)}$	$V_{C(PR,1)} / V_{A(PR,1)}$	-1	0	1	dB
P_R signal output gain difference (NTSC2/HD)	$G_{D/A(PR)}$	$V_{D(PR,1)} / V_{A(PR,1)}$	-1	0	1	dB
P_B, P_R signal output gain difference (HD)	$\Delta G_{A(C)}$	$V_{A(PB,1)} / V_{A(PR,1)}$	-1	0	1	dB
P_B, P_R signal output gain difference (MUSE)	$\Delta G_{B(C)}$	$V_{B(PB,1)} / V_{B(PR,1)}$	-1	0	1	dB
P_B, P_R signal output gain difference (NTSC1)	$\Delta G_{C(C)}$	$V_{C(PB,1)} / V_{C(PR,1)}$	-1	0	1	dB
P_B, P_R signal output gain difference (NTSC2)	$\Delta G_{D(C)}$	$V_{D(PB,1)} / V_{D(PR,1)}$	-1	0	1	dB
P_B signal frequency characteristics (HD)	$G_{A(PB,F)}$	$V_{A(PB,20)} / V_{A(PB,1)}$	-6	-3	0	dB
P_B signal frequency characteristics (MUSE)	$G_{B(PB,F)}$	$V_{B(PB,20)} / V_{B(PB,1)}$	-6	-3	0	dB
P_B signal frequency characteristics (NTSC1)	$G_{C(PB,F)}$	$V_{C(PB,16)} / V_{C(PB,1)}$	-6	-3	0	dB

■ Electrical Characteristics at $T_a = 25^\circ\text{C}$ (continued)

Parameter	Symbol	Conditions	Min	Typ	Max	Unit
C-D.L block (continued)						
P_B signal frequency characteristics (NTSC2)	$G_{D(PB,F)}$	$V_{D(PB,16)} / V_{D(PB,1)}$	-6	-3	0	dB
P_R signal frequency characteristics (HD)	$G_{A(PR,F)}$	$V_{A(PR,20)} / V_{A(PR,1)}$	-6	-3	0	dB
P_R signal frequency characteristics (MUSE)	$G_{B(PR,F)}$	$V_{B(PR,20)} / V_{B(PR,1)}$	-6	-3	0	dB
P_R signal frequency characteristics (NTSC1)	$G_{C(PR,F)}$	$V_{C(PR,16)} / V_{C(PR,1)}$	-6	-3	0	dB
P_R signal frequency characteristics (NTSC2)	$G_{D(PR,F)}$	$V_{D(PR,16)} / V_{D(PR,1)}$	-6	-3	0	dB
Y-D.L block						
Y output dynamic range	V_{DR27}	$V_{IN45} = 5.23 \text{ V to } 6.43 \text{ V}$	1.2	1.6	2.0	V[p-p]
Clamp pulse input threshold level	V_{TH43}		0.9	1.5	2.1	V
Delay time changeover switch Y1 threshold level	V_{TH39}		0.9	1.5	2.1	V
Delay time changeover switch Y2 threshold level	V_{TH40}		0.9	1.5	2.1	V
Y signal output gain (HD)	$G_{A(Y,1)}$	$V_{A(Y,1)} / 0.1 \text{ V[p-p]}$	1.81	2.92	3.91	dB
Y signal output gain (MUSE)	$G_{B(Y,1)}$	$V_{B(Y,1)} / 0.1 \text{ V[p-p]}$	1.81	2.92	3.91	dB
Y signal output gain (NTSC1)	$G_{C(Y,1)}$	$V_{C(Y,1)} / 0.1 \text{ V[p-p]}$	1.81	2.92	3.91	dB
Y signal output gain (NTSC2)	$G_{D(Y,1)}$	$V_{D(Y,1)} / 0.1 \text{ V[p-p]}$	1.81	2.92	3.91	dB
Y signal output gain difference (MUSE/HD)	$G_{B/A(Y)}$	$V_{B(Y,1)} / V_{A(Y,1)}$	-1	0	1	dB
Y signal output gain difference (NTSC1/HD)	$G_{C/A(Y)}$	$V_{C(Y,1)} / V_{A(Y,1)}$	-1	0	1	dB
Y signal output gain difference (NTSC2/HD)	$G_{D/A(Y)}$	$V_{D(Y,1)} / V_{A(Y,1)}$	-1	0	1	dB
Y_1 signal output gain (HD)	$G_{A(Y1,1)}$	$V_{A(Y1,1)} / 0.1 \text{ V[p-p]}$	12	15	18	dB
Y_1 signal output gain (MUSE)	$G_{B(Y1,1)}$	$V_{B(Y1,1)} / 0.1 \text{ V[p-p]}$	12	15	18	dB
Y_1 signal output gain(NTSC1)	$G_{C(Y1,1)}$	$V_{C(Y1,1)} / 0.1 \text{ V[p-p]}$	12	15	18	dB
Y_1 signal output gain (NTSC2)	$G_{D(Y1,1)}$	$V_{D(Y1,1)} / 0.1 \text{ V[p-p]}$	12	15	18	dB
Y_1 signal output gain difference (MUSE/HD)	$G_{B/A(Y1)}$	$V_{B(Y1,1)} / V_{A(Y1,1)}$	-1	0	1	dB
Y_1 signal output gain difference (NTSC1/HD)	$G_{C/A(Y1)}$	$V_{C(Y1,1)} / V_{A(Y1,1)}$	-1	0	1	dB
Y_1 signal output gain difference (NTSC2/HD)	$G_{D/A(Y1)}$	$V_{D(Y1,1)} / V_{A(Y1,1)}$	-1	0	1	dB
Y signal frequency characteristics (HD)	$G_{A(Y,F)}$	$V_{A(Y,30)} / V_{A(Y,1)}$	-4	-1	2	dB
Y signal frequency characteristics (MUSE)	$G_{B(Y,F)}$	$V_{B(Y,20)} / V_{B(Y,1)}$	-4	-1	2	dB
Y signal frequency characteristics (NTSC1)	$G_{C(Y,F)}$	$V_{C(Y,16)} / V_{C(Y,1)}$	-4	-1	2	dB
Y signal frequency characteristics (NTSC2)	$G_{D(Y,F)}$	$V_{D(Y,16)} / V_{D(Y,1)}$	-4	-1	2	dB

■ Electrical Characteristics at $T_a = 25^\circ\text{C}$ (continued)

Parameter	Symbol	Conditions	Min	Typ	Max	Unit
Sharpness block						
Sharpness mute switch threshold level	V_{TH25}		1.10	2.65	4.20	V
Contour part max. gain	V_{Rmax}		1.40	1.75	2.10	V[p-p]
Contour part sharpness typ. gain	$V_{R.SHtyp}$		640	800	960	mV[p-p]
Contour part sharpness min. gain	$V_{R.SHmin}$		0	15	30	mV[p-p]
Contour part sharpness gain ratio	$G_{R.SHtyp/max}$	$V_{R.SHtyp}/V_{Rmax}$	-8	-6	-4	dB
Detail part max. gain	V_{Smax}		390	520	650	mV[p-p]
Detail part sharpness typ. gain	$V_{S.SHtyp}$		195	260	325	mV[p-p]
Detail part sharpness min. gain	$V_{S.SHmin}$		0	5	10	mV[p-p]
Detail part sharpness gain ratio	$G_{S.SHtyp/max}$	$V_{S.SHtyp}/V_{Smax}$	-9	-6	-3	dB
Detail part sharpness mute max. gain (on)	$V_{S.SH(M.ON)}$		0	5	10	mV[p-p]
Detail part sharpness mute gain ratio (on/off)	$G_{S.SH(M.ON/OFF)}$	$V_{S.SH(M.ON)}/V_{Smax}$	-60	-50	-40	dB
Contour part						
Coring characteristics (on)	$V_{R.CO(ON)}$		210	280	350	mV[p-p]
Coring characteristics (off)	$V_{R.CO(OFF)}$		0	30	60	mV[p-p]
Correction primary differentiating signal gain (8 MHz)	$V_{R.CO(8M)}$		0.64	0.8	0.96	V[p-p]
Correction primary differentiating signal gain (4 MHz)	$V_{R.CO(4M)}$		1.16	1.45	1.74	V[p-p]
Correction primary differentiating signal gain ratio	$G_{R.CO(8M/4M)}$	$V_{R.CO(8M)}/V_{R.CO(4M)}$	-7	-5	-3	dB
Contour gain switch (LO)	$V_{R.SW(LO)}$		0.88	1.1	1.32	V[p-p]
Contour gain switch gain ratio	$G_{R.SW(L/H)}$	$V_{R.SW(LO)}/V_{Rmax}$	-5	-3	-1	dB
Detail part						
Typ. gain 1	V_{SG1typ}		210	280	350	mV[p-p]
Typ. gain 2	V_{SG2typ}		210	280	350	mV[p-p]
Gain ratio 1	$G_{SG1typ/max}$	V_{SG1typ}/V_{Smax}	-7	-5	-3	dB
Gain ratio 2	$G_{SG2typ/max}$	V_{SG2typ}/V_{Smax}	-7	-5	-3	dB
Detail part coring typ. gain	$V_{S.COtyp}$		225	315	445	mV[p-p]
Detail part coring min. gain	$V_{S.COmin}$		0	75	150	mV[p-p]
Detail part coring gain ratio	$G_{S.COtyp/max}$	$V_{S.COtyp}/V_{Smax}$	-8	-5	-2	dB
Detail part limiter max. gain	$V_{S.Lmax}$		460	580	700	mV[p-p]
Detail part limiter typ. gain	$V_{S.Ltyp}$		320	400	480	mV[p-p]
Detail part limiter gain ratio	$G_{S.Ltyp/max}$	$V_{S.Ltyp}/V_{S.Lmax}$	-5.5	-3.5	-1.5	dB

■ Electrical Characteristics at $T_a = 25^\circ\text{C}$ (continued)

Parameter	Symbol	Conditions	Min	Typ	Max	Unit
DSC block						
DSC detection characteristics (−35 dB)	$V_{\text{DSC}(-35)}$		2.7	3.4	4.1	V
DSC detection characteristics (−20 dB)	$V_{\text{DSC}(-20)}$		7	8.7	9	V
DSC detection characteristics (−15 dB)	$V_{\text{DSC}(-15)}$		6.9	8.6	9	V
DSC detection characteristics (−5 dB)	$V_{\text{DSC}(-5)}$		0.26	0.33	0.40	V
DSC coring characteristics	$V_{\text{D.CO}(-5)}$		6.9	8.6	9	V
DSC limiter characteristics	$V_{\text{D.LIM}(-20)}$		2.7	3.4	4.1	V
Child picture amp. block						
Child picture amp. max. gain	G_{CAmax}		10	12	14	dB
Child picture amp. typ. gain	G_{CAtyp}		3.5	5.5	7.5	dB
Child picture amp. gain ratio	$G_{\text{CAtyp}/\text{max}}$	$V_{\text{CAtyp}}/V_{\text{CAmax}}$	−8.5	−6.5	−4.5	dB
Child picture amp. frequency characteristics 1	$G_{\text{CA}(20\text{M})}$	$V_{\text{CA}(20\text{M})}/0.1\text{ V[p-p]}$	9.5	11.5	13.5	dB
Child picture amp. frequency characteristics 2	$G_{\text{CA}(1\text{M})}$	$V_{\text{CA}(1\text{M})}/0.1\text{ V[p-p]}$	9.5	11.5	13.5	dB
Child picture amp. frequency characteristics 3	$G_{\text{CA}(F)}$	$V_{\text{CA}(20\text{M})}/V_{\text{CA}(1\text{M})}$	−1	0	1	dB
VM pre-amp. block						
VM pre-amp. max. gain	G_{VMPmax}		10	12	14	dB
VM pre-amp. typ. gain	G_{VMPtyp}		3.5	5.5	7.5	dB
VM pre-amp. gain ratio	$G_{\text{VMPtyp}/\text{max}}$	$V_{\text{VMPtyp}}/V_{\text{VMPmax}}$	−8.5	−6.5	−4.5	dB
VM pre-amp. frequency characteristics 1	$G_{\text{VMP}(20\text{M})}$	$V_{\text{VMP}(20\text{M})}/0.1\text{ V[p-p]}$	9.5	11.5	13.5	dB
VM pre-amp. frequency characteristics 2	$G_{\text{VMP}(1\text{M})}$	$V_{\text{VMP}(1\text{M})}/0.1\text{ V[p-p]}$	9.5	11.5	13.5	dB
VM pre-amp. frequency characteristics 3	$G_{\text{VMP}(F)}$	$V_{\text{VMP}(20\text{M})}/V_{\text{VMP}(1\text{M})}$	−1	0	1	dB
VM limiter amp. block						
CY_S switch threshold level	V_{TH5}		0.45	0.75	1.05	V
Y_S switch threshold level	V_{TH6}		0.45	0.75	1.05	V
Output DC step (CY_S)	$\Delta V_{\text{VML}(\text{CY}_S)}$		−50	0	50	mV
Output DC step (Y_S)	$\Delta V_{\text{VML}(\text{Y}_S)}$		−50	0	50	mV
VM limiter amp. max. gain	G_{VMLmax}	$V_{\text{VMLmax}}/0.1\text{ V[p-p]}$	13.5	15.5	17.5	dB
VM limiter amp. typ. gain	G_{VMLtyp}	$V_{\text{VMLtyp}}/0.1\text{ V[p-p]}$	10.5	12.5	14.5	dB
VM limiter amp. gain ratio	$G_{\text{VMLtyp}/\text{max}}$	$V_{\text{VMLtyp}}/V_{\text{VMLmax}}$	−4.5	−2.5	−0.5	dB
VM limiter amp. frequency characteristics 1	$G_{\text{VML}(20\text{M})}$	$V_{\text{VML}(20\text{M})}/0.1\text{ V[p-p]}$	12.5	14.5	16.5	dB
VM limiter amp. frequency characteristics 2	$G_{\text{VML}(1\text{M})}$	$V_{\text{VML}(1\text{M})}/0.1\text{ V[p-p]}$	14.5	16.5	18.5	dB

■ Electrical Characteristics at $T_a = 25^\circ\text{C}$ (continued)

Parameter	Symbol	Conditions	Min	Typ	Max	Unit
VM limiter amp. block (continued)						
VM limiter amp. frequency characteristics 3	$G_{V_{ML}(F)}$	$V_{V_{ML}(20M)} / V_{V_{ML}(1M)}$	-4	-2	0	dB
VM limiter amp. limiter characteristics 1	$G_{V_{ML}(LIMmax)}$	$V_{V_{ML}(LIM.max)} / 0.2 \text{ V[p-p]}$	14	16	18	dB
VM limiter amp. limiter characteristics 2	$G_{V_{ML}(LIMtyp)}$	$V_{V_{ML}(LIM.typ)} / 0.2 \text{ V[p-p]}$	6	8	10	dB
VM limiter amp. limiter characteristics 3	$G_{V_{ML}(LIM)}$	$V_{V_{ML}(LIM.typ)} / V_{V_{ML}(LIM.max)}$	-10	-8	-6	dB
Y_S operation characteristics	$G_{V_{ML}(YS)}$	$V_{V_{ML}(YS)} / V_{V_{ML}(max)}$	-36	-30	-24	dB
CY_S operation characteristics	$G_{V_{ML}(CYS)}$	$V_{V_{ML}(CYS)} / V_{V_{ML}(max)}$	-36	-30	-24	dB

• Design reference data

Note) The characteristics listed below are theoretical values based on the IC design and are not guaranteed.

Parameter	Symbol	Conditions	Min	Typ	Max	Unit
C-D.L block						
P_B signal delay time (HD)	$t_{A(PB)}$	At DL = HD	40	50	60	ns
P_B signal delay time (MUSE)	$t_{B(PB)}$	At DL = MUSE	52	65	78	ns
P_B signal delay time (NTSC1)	$t_{C(PB)}$	At DL = NTSC1	60	75	90	ns
P_B signal delay time (NTSC2)	$t_{D(PB)}$	At DL = NTSC2	72	90	108	ns
P_B signal delay time variation amount (MUSE to HD)	$t_{1(PB)}$	$t_{B(PB)} - t_{A(PB)}$	12	16	20	ns
P_B signal delay time variation amount (NTSC1 to HD)	$t_{2(PB)}$	$t_{C(PB)} - t_{A(PB)}$	20	26	32	ns
P_R signal delay time (HD)	$t_{A(PR)}$	At DL = HD	40	50	60	ns
P_R signal delay time (MUSE)	$t_{B(PR)}$	At DL = MUSE	52	65	78	ns
P_R signal delay time (NTSC1)	$t_{C(PR)}$	At DL = NTSC1	60	75	90	ns
P_R signal delay time (NTSC2)	$t_{D(PR)}$	At DL = NTSC2	72	90	108	ns
P_R signal delay time variation amount (MUSE to HD)	$t_{1(PR)}$	$t_{B(PR)} - t_{A(PR)}$	12	16	20	ns
P_R signal delay time variation amount (NTSC1 to HD)	$t_{2(PR)}$	$t_{C(PR)} - t_{A(PR)}$	20	26	32	ns
P_B, P_R delay time difference (HD)	$\Delta t_{A(C)}$	$t_{A(PB)} - t_{A(PR)}$	-6	0	6	ns
P_B, P_R delay time difference (MUSE)	$\Delta t_{B(C)}$	$t_{B(PB)} - t_{B(PR)}$	-6	0	6	ns
P_B, P_R delay time difference (NTSC1)	$\Delta t_{C(C)}$	$t_{C(PB)} - t_{C(PR)}$	-6	0	6	ns
P_B, P_R delay time difference (NTSC2)	$\Delta t_{D(C)}$	$t_{D(PB)} - t_{D(PR)}$	-6	0	6	ns

■ Electrical Characteristics at $T_a = 25^\circ\text{C}$ (continued)

• Design reference data

Note) The characteristics listed below are theoretical values based on the IC design and not guaranteed.

Parameter	Symbol	Conditions	Min	Typ	Max	Unit
Y-D.L block						
Y signal delay time (HD)	$t_{A(Y)}$	At DL = HD	40	50	60	ns
Y signal delay time (MUSE)	$t_{B(Y)}$	At DL = MUSE	52	65	78	ns
Y signal delay time (NTSC1)	$t_{C(Y)}$	At DL = NTSC1	60	75	90	ns
Y signal delay time (NTSC2)	$t_{D(Y)}$	At DL = NTSC2	72	90	108	ns
Y signal delay time variation amount (MUSE to HD)	$t_{1(Y)}$	$t_{B(Y)} - t_{A(Y)}$	12	16	20	ns
Y signal delay time variation amount (NTSC1 to HD)	$t_{2(Y)}$	$t_{C(Y)} - t_{A(Y)}$	20	26	32	ns
Y_1 signal delay time (HD)	$t_{A(Y1)}$	At DL = HD	32	40	48	ns
Y_1 signal delay time (MUSE)	$t_{B(Y1)}$	At DL = MUSE	40	50	60	ns
Y_1 signal delay time (NTSC1)	$t_{C(Y1)}$	At DL = NTSC1	44	55	66	ns
Y_1 signal delay time (NTSC2)	$t_{D(Y1)}$	At DL = NTSC2	48	60	72	ns
Y_1 signal delay time variation amount (MUSE to HD)	$t_{1(Y1)}$	$t_{B(Y1)} - t_{A(Y1)}$	4	8	12	ns
Y_1 signal delay time variation amount (NTSC1 to HD)	$t_{2(Y1)}$	$t_{C(Y1)} - t_{A(Y1)}$	10	14	18	ns

■ Terminal Equivalent Circuits

Pin No.	Equivalent circuit	Description
1		<p>Pin 1: P_R input signal pin: Pin 47: P_B input signal pin:</p> <ul style="list-style-type: none"> Clamps input signal with clamp pulse of pin 43 Drive with low impedance. Recommended application method: Don't apply DC voltage directly to pin.
2		<p>VM pre-amp. input pin:</p> <ul style="list-style-type: none"> Control voltage: typ. 3V <ul style="list-style-type: none"> Recommended application range: 0 V to V_{CC}

■ Terminal Equivalent Circuits (continued)

Pin No.	Equivalent circuit	Description
3		<p>VM pre-amp. input pin:</p> <ul style="list-style-type: none"> • Drive with low impedance. • Recommended application method: Don't apply DC voltage directly to pin.
4		<p>VM pre-amp. output pin:</p> <ul style="list-style-type: none"> • Recommended application range: -3.2 mA to +3.2 mA
5 6		<p>Pin5: Child picture Y_S input pin: Pin6: Y_S input pin:</p> <ul style="list-style-type: none"> • Control pin for on/off of VM limiter amp. High: Off Low: On ($V_{TH} = 0.75 V$) • Recommended application range: 0 V to V_{CC}
7		<p>VM limiter amp. input pin:</p> <ul style="list-style-type: none"> • Drive with low impedance. • Recommended application method: Don't apply DC voltage directly to pin.

■ Terminal Equivalent Circuits (continued)

Pin No.	Equivalent circuit	Description
8		<p>VM limiter amp. gain control pin:</p> <ul style="list-style-type: none"> Control voltage: typ. 2.5 V <ul style="list-style-type: none"> Recommended application range: 0 V to V_{CC}
9		<p>VM limiter amp. output pin:</p> <ul style="list-style-type: none"> Recommended application range: -3.2 mA to +3.2 mA
10		<p>Child picture amp. output pin:</p> <ul style="list-style-type: none"> Recommended application range: -3.2 mA to +3.2 mA
11		<p>Child picture amp. gain control pin:</p> <ul style="list-style-type: none"> Control voltage: typ. 3 V <ul style="list-style-type: none"> Recommended use range: 0 V to V_{CC}

■ Terminal Equivalent Circuits (continued)

Pin No.	Equivalent circuit	Description
12		<p>Child picture amp. input pin:</p> <ul style="list-style-type: none"> • Drive with low impedance. • Recommended application method: Don't apply DC voltage directly to pin.
13		<p>Pin 13: P_R output signal pin: Pin 15: P_B output signal pin:</p> <ul style="list-style-type: none"> • Recommended application range: -1.6 mA to +1.6 mA
14	<p style="text-align: center;">—</p>	<p>N.C. pin:</p> <ul style="list-style-type: none"> • Keep grounded
15	<p style="text-align: center;">Refer to pin 13</p>	<p style="text-align: center;">Refer to pin 13</p>
16		<p>DSC large signal gain control pin:</p> <ul style="list-style-type: none"> • Controls gain of large signal coring amp. on DSC detection. • Control voltage: typ. 3 V <ul style="list-style-type: none"> • Recommended application range: 0 V to V_{CC}
17		<p>Primary differentiating input pin before correction:</p> <ul style="list-style-type: none"> • Y1 primary differentiating signal outputted from pin 24 is inputted with capacitor coupling. • Drive with low impedance. • Recommended application method: Don't apply DC voltage directly to pin.

■ Terminal Equivalent Circuits (continued)

Pin No.	Equivalent circuit	Description
18	—	N.C. pin: • Keep grounded
19		Power supply pin: • Apply 9 V when use
20		DSC detection output pin: • Controls voltage of DSC. • Left diagram shows recommended external circuit. • Recommended application range: -1.6 mA to +1.6 mA
21		DSC small signal gain control pin: • Controls gain of small signal limiter amp. on DSC detection. • Control voltage: typ. 3 V • Recommended application range: 0 V to V_{CC}
22		DSC input pin: • Y signal is inputted for DSC detection. • Left diagram shows recommended external circuit. • Recommended application method: Not apply DC voltage directly to pin.

■ Terminal Equivalent Circuits (continued)

Pin No.	Equivalent circuit	Description
23		<p>DSC bias pin:</p> <ul style="list-style-type: none"> • No use. Keep it connected to V_{CC} • Recommended application range: 0 V to V_{CC}
24		<p>Primary differentiating input pin before correction:</p> <ul style="list-style-type: none"> • Output Y1 primary differentiating signal which is made by Y signal inputted from pin 45. • Recommended application range: -1.6 mA to +1.6 mA
25 26		<p>Pin 25: Sharpness mute control pin: Pin 26: Sharpness gain control pin:</p> <ul style="list-style-type: none"> • Controls contour correction amount of pin 27 Y output signal by pin 26 voltage. $V_{26typ} = 3\text{ V}$ <p>Correction amount</p> <p>V_{26}</p> <ul style="list-style-type: none"> • On/off pin of contour correction signal by high/low of pin 25. • High: Off Low: On ($V_{TH} = 2.65\text{ V}$) • Recommended application range: 0 V to V_{CC}
27		<p>Y output pin:</p> <ul style="list-style-type: none"> • Outputs Y signal in which contour correction signal has been added on Y signal inputted from pin 45. • Recommended application range: -3.2 mA to +3.2 mA

■ Terminal Equivalent Circuits (continued)

Pin No.	Equivalent circuit	Description
<p>28 29</p>		<p>Pin 28: Contour part gain control pin: Pin 29: Contour part bias pin:</p> <ul style="list-style-type: none"> • Contour part amp. gain can be switched in 2 steps by high/low of pin 28 voltage. • High: Contour part gain high Low: Contour part gain low ($V_{TH} = 1.5\text{ V}$) • Smooths pin 29 signal by an external capacitor. • Recommended application range (pin 28): 0 V to V_{CC} • Recommended application method (pin 29): Don't apply DC voltage directly to pin.
<p>30</p>		<p>Secondary differentiating input pin:</p> <ul style="list-style-type: none"> • With an external circuit, differentiate the primary differential signal that has been done contour correction and which is outputted from pin 32, then input it to pin 30. • Recommended application method: Don't apply DC voltage directly to pin.
<p>31</p>		<p>Detail part gain control pin:</p> <ul style="list-style-type: none"> • Controls gain of small signal detail part amp. by pin 31 voltage. $V_{31typ} = 3\text{ V}$ <div style="text-align: center;"> <p>Detail part gain</p> <p>V_{31}</p> </div> <ul style="list-style-type: none"> • Recommended application range: 0 V to V_{CC}
<p>32</p>		<p>Primary differentiating output after correction pin:</p> <ul style="list-style-type: none"> • Outputs a primary differentiated signal as a signal for contour part edge switching. • Recommended application range: -1.6 mA to +1.6 mA

■ Terminal Equivalent Circuits (continued)

Pin No.	Equivalent circuit	Description
33 34		<p>Pin 33: Detail part coring control pin: Pin 34: Detail part coring bias pin:</p> <ul style="list-style-type: none"> Controls gain of detail part coring amp. by pin 33 voltage. $V_{33typ} = 3\text{ V}$ <ul style="list-style-type: none"> Smooths pin 34 signal with an external capacitor. Recommended application range (pin 33): 0 V to V_{CC} Recommended application method (pin 34): Don't apply DC voltage directly to pin.
35		<p>Differentiating signal bias 1 pin:</p> <ul style="list-style-type: none"> Makes a necessary bias by smoothing with an external capacitor to run a contour correction for the primary differentiating signal inputted from pin 17. Recommended application method: Don't apply DC voltage directly to pin.
36		<p>Contour part and detail part separation level control pin:</p> <ul style="list-style-type: none"> Controls separation level of contour part (large signal) and detail part (small signal) by pin 36 voltage $V_{36typ} = 3\text{ V}$ <ul style="list-style-type: none"> Recommended application range: 0 V to V_{CC}

■ Terminal Equivalent Circuits (continued)

Pin No.	Equivalent circuit	Description
37		<p>Differentiating signal bias 2 pin:</p> <ul style="list-style-type: none"> Necessary bias is made by an smoothing external capacitor in order to correct contour of primary differentiating signal inputted from Pin17 Recommended application method: Don't apply DC voltage directly to pin.
38		<p>Detail part limiter output pin:</p> <ul style="list-style-type: none"> Outputs detail part limiter signal Recommended application range: -1.6 mA to +1.6 mA
39 40		<p>Pin 39: Y delay line changeover switch-1 pin: Pin 40: Y delay line changeover switch-2 pin: Pin 46: C delay line changeover switch-1 pin: Pin 48: C delay line changeover switch-2 pin:</p> <ul style="list-style-type: none"> Correction amount of Y, C delay line are switched by high/low of each pin voltage. ($V_{TH} = 1.5 V$) Pin 39, pin 46 High: Off, low: +10 ns Pin 40, pin 48 High: Off, low: +20 ns Recommended application range: 0 V to V_{CC}
41	—	<p>N.C. pin:</p> <ul style="list-style-type: none"> Keep grounded
42	—	<p>GND pin:</p>

■ Terminal Equivalent Circuits (continued)

Pin No.	Equivalent circuit	Description
43		<p>Clamp pulse input pin:</p> <ul style="list-style-type: none"> • Clamps inputted signal from each pin of pin 45, pin 47, pin 1 ($V_{TH} = 1.5\text{ V}$) • High: Clamp on • Low: Clamp off • Recommended pulse width (clamp on period) NTSC: 2.5 μs HD: 1.0 μs • Recommended application range: 0 V to V_{CC}
44	—	<p>N.C. pin:</p> <ul style="list-style-type: none"> • Keep grounded
45		<p>Y input signal pin:</p> <ul style="list-style-type: none"> • Clamps input signal with Pin43 clamp pulse • Drive with low impedance • Recommended application method: Don't apply DC voltage directly to pin.
46	Refer to pin 39	Refer to pin 39
47	Refer to pin 1	Refer to pin 1
48	Refer to pin 39	Refer to pin 39

Request for your special attention and precautions in using the technical information and semiconductors described in this material

- (1) An export permit needs to be obtained from the competent authorities of the Japanese Government if any of the products or technologies described in this material and controlled under the "Foreign Exchange and Foreign Trade Law" is to be exported or taken out of Japan.
- (2) The technical information described in this material is limited to showing representative characteristics and applied circuit examples of the products. It does not constitute the warranting of industrial property, the granting of relative rights, or the granting of any license.
- (3) The products described in this material are intended to be used for standard applications or general electronic equipment (such as office equipment, communications equipment, measuring instruments and household appliances).
Consult our sales staff in advance for information on the following applications:
 - Special applications (such as for airplanes, aerospace, automobiles, traffic control equipment, combustion equipment, life support systems and safety devices) in which exceptional quality and reliability are required, or if the failure or malfunction of the products may directly jeopardize life or harm the human body.
 - Any applications other than the standard applications intended.
- (4) The products and product specifications described in this material are subject to change without notice for reasons of modification and/or improvement. At the final stage of your design, purchasing, or use of the products, therefore, ask for the most up-to-date Product Standards in advance to make sure that the latest specifications satisfy your requirements.
- (5) When designing your equipment, comply with the guaranteed values, in particular those of maximum rating, the range of operating power supply voltage and heat radiation characteristics. Otherwise, we will not be liable for any defect which may arise later in your equipment.
Even when the products are used within the guaranteed values, redundant design is recommended, so that such equipment may not violate relevant laws or regulations because of the function of our products.
- (6) When using products for which dry packing is required, observe the conditions (including shelf life and after-unpacking standby time) agreed upon when specification sheets are individually exchanged.
- (7) No part of this material may be reprinted or reproduced by any means without written permission from our company.

Please read the following notes before using the datasheets

- A. These materials are intended as a reference to assist customers with the selection of Panasonic semiconductor products best suited to their applications.
Due to modification or other reasons, any information contained in this material, such as available product types, technical data, and so on, is subject to change without notice.
Customers are advised to contact our semiconductor sales office and obtain the latest information before starting precise technical research and/or purchasing activities.
- B. Panasonic is endeavoring to continually improve the quality and reliability of these materials but there is always the possibility that further rectifications will be required in the future. Therefore, Panasonic will not assume any liability for any damages arising from any errors etc. that may appear in this material.
- C. These materials are solely intended for a customer's individual use.
Therefore, without the prior written approval of Panasonic, any other use such as reproducing, selling, or distributing this material to a third party, via the Internet or in any other way, is prohibited.



LittleDiode supplies new, hard to find or obsolete electronic components and semiconductors all over the world.

With over two million different components listed you are sure to find the part you need.

Feel free to visit us today at our online store:

LittleDiode.com

Looking forward to providing you with the best possible service.