

# AN5295NK

## 3-ch. sound signal processing single chip IC for TV (with I<sup>2</sup>C bus)

### ■ Overview

The AN5295NK is a television-use 3-ch. sound signal processing IC which incorporates volume, tone control (L/R/C 3-ch.), and surround sound, sound AGC, lower sound enforce (L/R 2-ch.) functions. All of the functions (including changeover switch) including external I/O port can be controlled by I<sup>2</sup>C bus.

### ■ Features

- 3-ch. of volumes can be controlled independently (max. attenuation is 75 dB or more)
- Center output can be switched, either center input or inside L+R signal (for HDTV)
- Lower sound enforce effect (frequency and gain) can be adjusted with external parts
- With L+R output

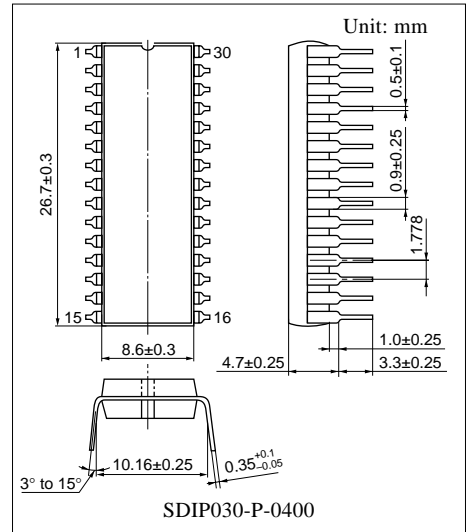

### ■ Applications

- Television

### ■ Block Diagram

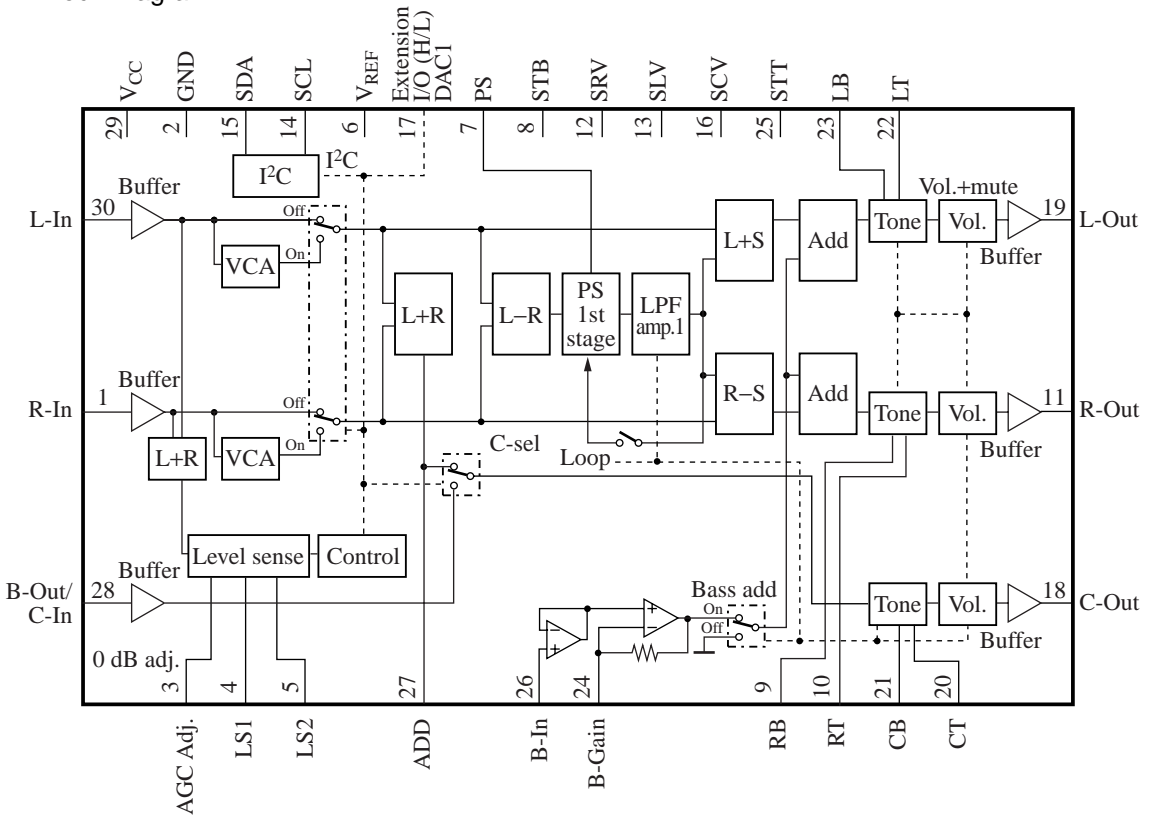

### ■ Pin Descriptions

Pin No.	Description	Pin No.	Description
1	R-ch. input pin	16	C-ch. volume DAC output pin
2	Ground pin	17	Extension DAC pin 1
3	AGC 0 dB adjustment pin	18	C-ch. output pin
4	AGC level sensor-1 pin	19	L-ch. output pin
5	AGC level sensor-2 pin	20	C-ch. treble $f_C$ setting pin
6	1/2 $V_{CC}$ pin	21	C-ch. bass $f_C$ setting pin
7	Phase shift pin	22	L-ch. treble $f_C$ setting pin
8	L/R/C-ch. bass DAC output pin	23	L-ch. bass $f_C$ setting pin
9	R-ch. bass $f_C$ setting pin	24	Bass mix. gain adjustment pin
10	R-ch. treble $f_C$ setting pin	25	L/R/C-ch. treble DAC output pin
11	R-ch. output pin	26	Bass detection LPF ope.-amp. input pin
12	R-ch. volume DAC output pin	27	L+R add after AGC output pin
13	L-ch. volume DAC output pin	28	C-ch. input pin
14	I <sup>2</sup> C communication clock pin	29	Power supply pin (12 V)
15	I <sup>2</sup> C communication data pin	30	L-ch. input pin

### ■ Absolute Maximum Ratings

Parameter	Symbol	Rating	Unit
Supply voltage	$V_{CC}$	13.5	V
Supply current	$I_{CC}$	80	mA
Power dissipation *2	$P_D$	1 143	mW
Operating ambient temperature *1	$T_{opr}$	-20 to +75	°C
Storage temperature *1	$T_{stg}$	-55 to +150	°C

Note) \*1: Except for the operating ambient temperature and storage temperature, all ratings are for  $T_a = 25^\circ\text{C}$ .

\*2:  $T_a = 70^\circ\text{C}$ .

### ■ Recommended Operating Range

Parameter	Symbol	Range	Unit
Supply voltage	$V_{CC}$	10.8 to 13.2	V

### ■ Electrical Characteristics at $T_a = 25^\circ\text{C}$

Parameter	Symbol	Conditions	Min	Typ	Max	Unit
<b>Tone control</b>						
Volume max. level *	$V_{VO(max)}$	$V_{IN} = 1\text{ V[rms]}, f = 1\text{ kHz}$	-2.3	-0.3	1.7	dB
Volume typ. level *	$V_{VO(typ)}$	$V_{IN} = 1\text{ V[rms]}, f = 1\text{ kHz}$	-16.2	-13.2	-10.2	dB
Volume min. level *	$V_{VO(min)}$	$V_{IN} = 1\text{ V[rms]}, f = 1\text{ kHz}$	—	—	-75	dB
Bass: boost level	$V_{BB}$	$V_{IN} = 400\text{ mV[rms]}, f = 50\text{ Hz}$	9.2	11.2	13.2	dB
Bass: cut level	$V_{BC}$	$V_{IN} = 400\text{ mV[rms]}, f = 50\text{ Hz}$	-11.7	-9.7	-7.7	dB
Treble: boost level	$V_{TB}$	$V_{IN} = 400\text{ mV[rms]}, f = 20\text{ kHz}$	9.7	11.7	13.7	dB
Treble: cut level	$V_{TC}$	$V_{IN} = 400\text{ mV[rms]}, f = 20\text{ kHz}$	-12.1	-10.1	-8.1	dB
<b>AGC</b>						
Input/output level 1 *	$V_{AGC1}$	$V_{IN} = 1\text{ mV[rms]}, f = 1\text{ kHz}$	0.7	1.7	2.7	mV[rms]
Input/output level 2 *	$V_{AGC2}$	$V_{IN} = 50\text{ mV[rms]}, f = 1\text{ kHz}$	70	110	150	mV[rms]
Input/output level 3 *	$V_{AGC3}$	$V_{IN} = 1\text{ V[rms]}, f = 1\text{ kHz}$	275	345	415	mV[rms]
Circuit current *	$I_{CC}$	$V_{IN} = 0\text{ mV}$	25	45	65	mA
Total harmonics distortion *	THD	$V_{IN} = 1\text{ V[rms]}, f = 1\text{ kHz}$	—	0.1	0.5	%
Max. input voltage *	$V_{IN(max)}$	THD = 1%	2.8	—	—	V[rms]
Mute level *	$V_{MUTE}$	$V_{IN} = 1\text{ V[rms]}, f = 1\text{ kHz}$	—	—	-80	dB
Noise level at volume max. *	$V_{NO(max)}$	$V_{IN} = 0\text{ mV}, R_g = 0\ \Omega$	—	115	200	$\mu\text{V[rms]}$
Noise level at volume min. *	$V_{NO(min)}$	$V_{IN} = 0\text{ mV}, R_g = 0\ \Omega$	—	45	100	$\mu\text{V[rms]}$
Surround level (max.) *	$V_{SU(max)}$	$V_{IN} = 100\text{ mV[rms]}, f = 1\text{ kHz}$	12.4	14.4	16.4	dB
Surround level (min.) *	$V_{SU(min)}$	$V_{IN} = 100\text{ mV[rms]}, f = 1\text{ kHz}$	2.9	4.9	6.9	dB
Surround level at loop on *	$V_{LPSUL}$	$V_{IN} = 100\text{ mV[rms]}, f = 1\text{ kHz}$	4.9	6.9	8.9	dB
Level at bass add on *	$V_{BAONL}$	$V_{IN} = 400\text{ mV[rms]}, f = 50\text{ Hz}$	3.95	5.95	7.95	dB
Cross talk *	CT	$V_{IN} = 1\text{ V[rms]}, f = 1\text{ kHz}$	—	-70	-68.5	dB
Channel balance *	CB	$V_{IN} = 1\text{ V[rms]}, f = 1\text{ kHz}$	-1.5	0	1.5	dB
L-R volume tracking (1/4) *	$V_{TR}$	$V_{IN} = 1\text{ V[rms]}, f = 1\text{ kHz}$	-2.0	0	2.0	dB
<b>I<sup>2</sup>C interface</b>						
Sink current at ACK	$I_{ACK}$	Maximum value of pin 15 sink current at ACK	2.0	10	—	mA
SCL, SDA signal high-level input	$V_{IHI}$		3.5	—	5.0	V
SCL, SDA signal low-level input	$V_{ILO}$		0	—	0.9	V
Max. allowable input frequency	$f_{Imax}$		—	—	100	kbit/s

Note) \* : Uses DIN audio filter.

■ Electrical Characteristics at  $T_a = 25^\circ\text{C}$  (continued)

• Design reference data

Note) The characteristics listed below are theoretical values based on the IC design and are not guaranteed.

Parameter	Symbol	Conditions	Min	Typ	Max	Unit
<b>I<sup>2</sup>C interface</b>						
Bus free before start	$t_{\text{BUS}}$		4.0	—	—	$\mu\text{s}$
Start condition setup time	$t_{\text{SU, STA}}$		4.0	—	—	$\mu\text{s}$
Start condition hold time	$t_{\text{HD, STA}}$		4.0	—	—	$\mu\text{s}$
Low period SCL, SDA	$t_{\text{LO}}$		4.0	—	—	$\mu\text{s}$
High period SCL	$t_{\text{HI}}$		4.0	—	—	$\mu\text{s}$
Rise time SCL, SDA	$t_r$		—	—	1.0	$\mu\text{s}$
Fall time SCL, SDA	$t_f$		—	—	0.35	$\mu\text{s}$
Data setup time (write)	$t_{\text{SU, DAT}}$		0.25	—	—	$\mu\text{s}$
Data hold time (write)	$t_{\text{HD, DAT}}$		0	—	—	$\mu\text{s}$
Acknowledge setup time	$t_{\text{SU, ACK}}$		—	—	3.5	$\mu\text{s}$
Acknowledge hold time	$t_{\text{HD, ACK}}$		0	—	—	$\mu\text{s}$
Stop condition setup time	$t_{\text{SU, STO}}$		4.0	—	—	$\mu\text{s}$
<b>DAC</b>						
6-bit DAC DNLE	$L_6$	$1 \text{ LSB} = (\text{data (max.)} - \text{data (00)})/63$	0.1	1.0	1.9	LSB/step

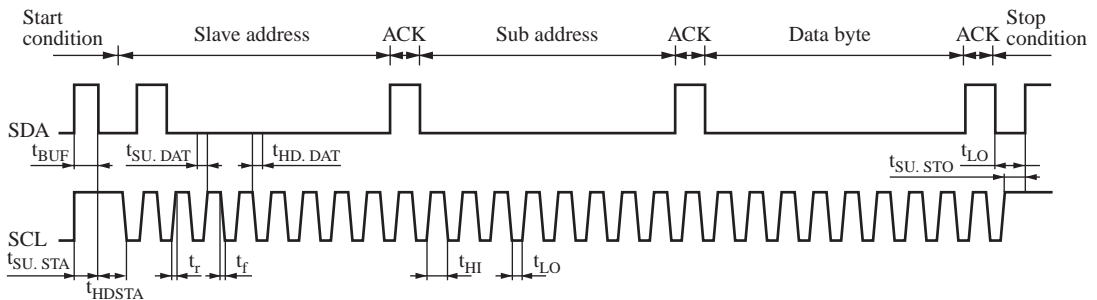

■ Terminal Equivalent Circuits

Pin No.	Equivalent circuit	Description	Voltage (V)
1		R-In: R-ch. Input pin	6
2	—	GND: GND pin	0

■ Terminal Equivalent Circuits (continued)

Pin No.	Equivalent circuit	Description	Voltage (V)
3		AGC Adj.: AGC on/off changeover AGC off at 1.2 V or less.	—
4		LS1: AGC level sensor 1	7
5		LS2: AGC level sensor 1, 2	0.5 to 1.5
6		$V_{REF}$ : Reference voltage to be stabilized	6
7		PS: Phase shift pin	6
8		STB: L/R/C-ch. bass DAC output pin	3±1

### ■ Terminal Equivalent Circuits (continued)

Pin No.	Equivalent circuit	Description	Voltage (V)
9		RB: R-ch. bass $f_C$ setting pin	6
10		RT: R-ch. treble $f_C$ setting pin	6
11		R-Out: R-ch. output pin	6
12		SRV: R-ch. volume DAC output pin	$3 \pm 1$
13		SLV: L-ch. volume DAC output pin	$3 \pm 1$
14		SCL: I <sup>2</sup> C bus clock input pin	$V_{CC}$

■ Terminal Equivalent Circuits (continued)

Pin No.	Equivalent circuit	Description	Voltage (V)
15		SDA: I <sup>2</sup> C bus data input pin	V <sub>CC</sub>
16		SCV: C-ch. volume DAC output pin	3±1
17		DAC1: Extension DAC output pin	0 or 5
18		C-Out: C-ch. output pin	6
19		L-Out: L-ch. output pin	6
20		CT: C-ch. treble f <sub>C</sub> setting pin	6

### ■ Terminal Equivalent Circuits (continued)

Pin No.	Equivalent circuit	Description	Voltage (V)
21		CB: C-ch. bass $f_C$ setting pin	6
22		LT: L-ch. treble $f_C$ setting pin	6
23		LB: L-ch. bass $f_C$ setting pin	6
24		B-Gain: Bass mix. gain adjustment pin	6
25		STT: L/R/C-ch. treble DAC output pin	$3 \pm 1$
26		B-In: Bass detection LPF ope.-amp. input pin	6

■ Terminal Equivalent Circuits (continued)

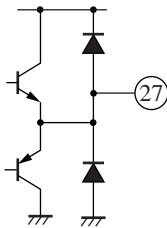
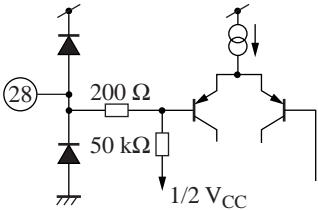
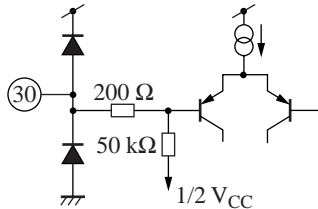
Pin No.	Equivalent circuit	Description	Voltage (V)
27		ADD: L+R (after AGC) output pin	6
28		C-In: C-ch. input pin	6
29	—	V <sub>CC</sub> : Power supply pin	12
30		L-In: L-ch. input pin	6

■ Technical Information

• I<sup>2</sup>C bus

1. DAC

- 1) Built-in 5 DAC controls and 8 switches
- 2) Incorporating auto-increment functions
  - (1) Sub address 0\* : Auto-increment mode  
(Data are inputted by the change of sub-address according to the transfer when data are sequentially transferred.)
  - (2) Sub address 8\* : Data renewal mode  
(Data are inputted with the same sub-address when data are sequentially transferred.)

3) I<sup>2</sup>C bus protocol

- (1) Slave address: 10000000 (80H)
- (2) Format (normal)

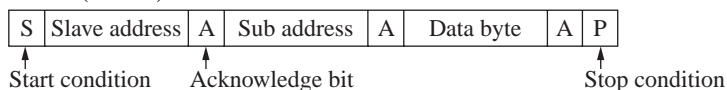

- (3) Auto-increment mode/data renewal mode

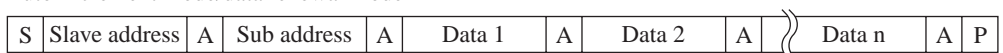

- 4) Typical data should be inputted at power on because initial state of DAC is not guaranteed.

■ Technical Information (continued)

• I<sup>2</sup>C bus (continued)

2. I<sup>2</sup>C bus transfer sequence

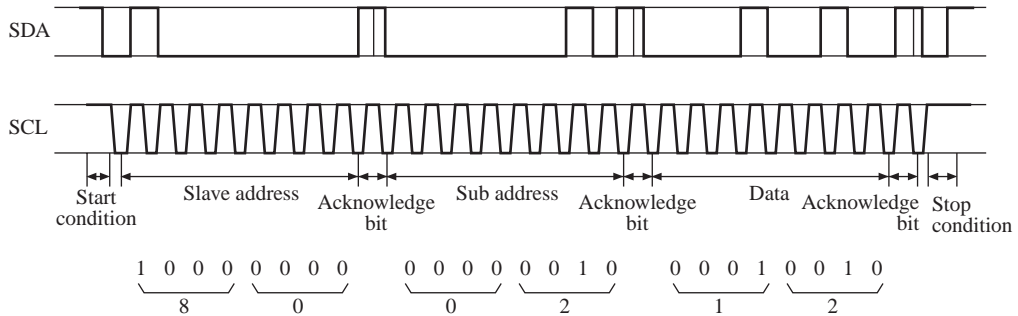

Transfer message example

Two type of transfer messages of SCL and SDA are sent by synchronous serial transfer. SCL is a clock of constant frequency and SDA indicates address data to control receiving side and is sent in parallel by synchronizing with SCL. Data are transferred in principle with 8-bit 3 octet (byte) and acknowledge bit exists every one octet. Frame organization are described as follows:

- 1) Start condition      When SDA becomes low from high at SCA = high, receiver is on a data receiving mode.
- 2) Stop condition      When SDA becomes high from low at SCA = high, receiver stops receiving data.
- 3) Slave address      Address determined by device. Receiving is stopped when address of another device is sent.
- 4) Sub address      Address determined by function
- 5) Data      Data to control
- 6) Acknowledge bit      To let the master acknowledge that data has been received for each octet in such manner that the master sends a high signal and the receiver sends back a low signal as shown by above transfer sequence.

SDA is not changed when SCL is high except start and stop conditions.

3. Sub address byte and data byte format

Sub address	Data byte							
	D7	D6	D5	D4	D3	D2	D1	D0
00	← L-ch. vol. →						Mute on/off	AGC on/off
01	← R-ch. vol. →						C-ch. mute on/off	Surround on/off
02	← C-ch. vol. →						Bass mix. on/off	C-In select
03	← L/R/C treble →				← L/R/C bass →			
04	0	0	0	0	0	0	0	0
05	← Surround effect →				Surround loop on/off	0	0	DAC1 L/H

■ Technical Information (continued)

• I<sup>2</sup>C bus (continued)

3. Sub address byte and data byte format (continued)

- |  |   |
|--|---|
| <p>1) L-ch. Vol., R-ch. Vol., C-ch. Vol.<br/>Min. at data = 00<br/>Max. at data = 3F</p> <p>2) L/R/C treble, L/R/C bass<br/>Min. at data = 0<br/>Max. at data = F</p> <p>3) Surround effect<br/>Min. at data = 0<br/>Max. at data = F</p> <p>4) Switches (except C-ch. mute SW)<br/>Off at data = 0<br/>On at data = 1</p> | <p>5) DAC1<br/>Low (0 V) at data = 0<br/>High (5 V) at data = 1</p> <p>6) C-In select<br/>L+R in at data = 0<br/>C-In at data = 1</p> <p>7) C-ch. mute<br/>Off at data = 0<br/>On at data = 1</p> |
|--|---|

■ Application Circuit Example

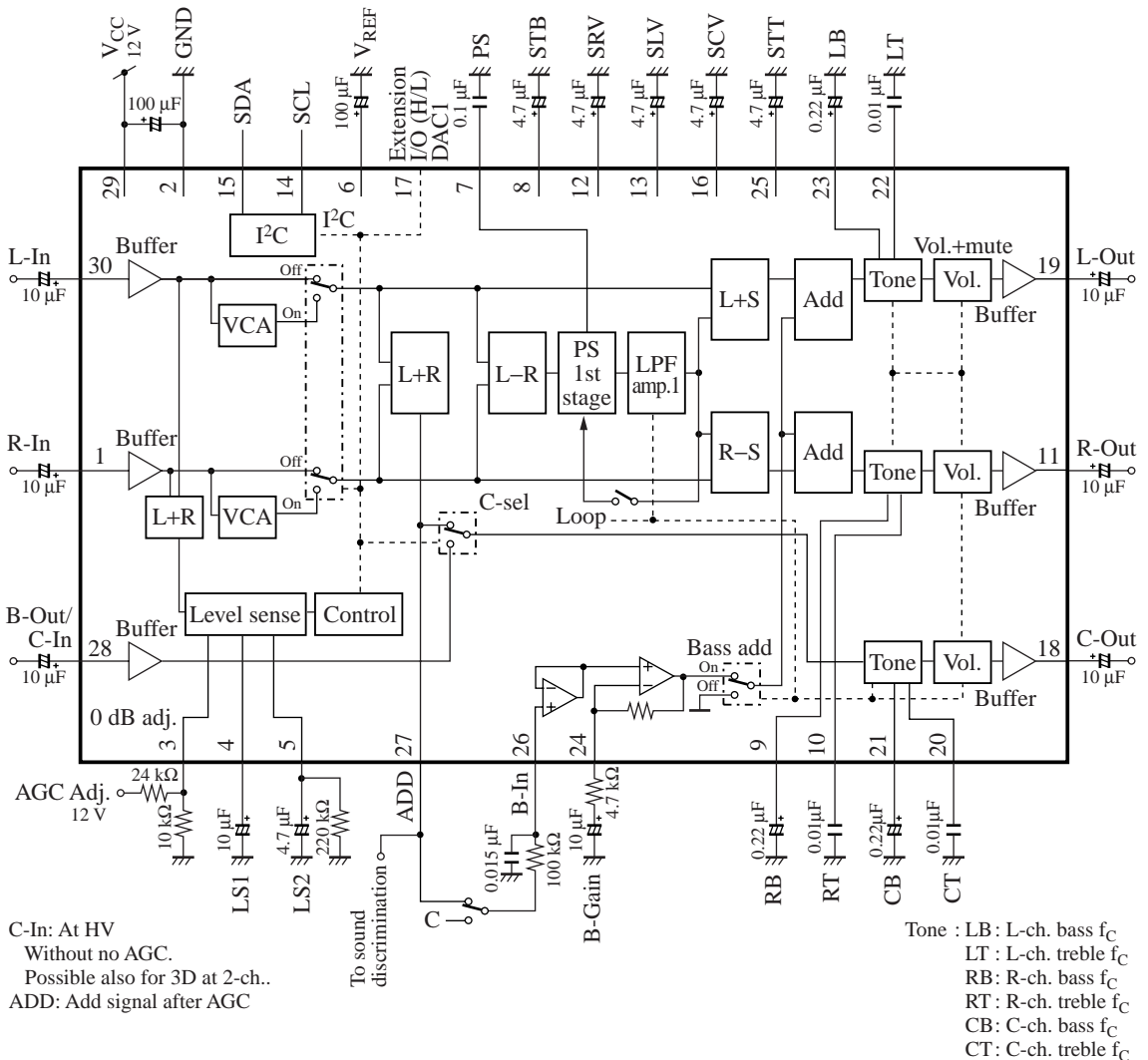



LittleDiode supplies new, hard to find or obsolete electronic components and semiconductors all over the world.

With over two million different components listed you are sure to find the part you need.

Feel free to visit us today at our online store:

[LittleDiode.com](http://LittleDiode.com)

Looking forward to providing you with the best possible service.