

**EFFECTIVE FILTERING OF TDE1707**

by Ugo Morriconi

The TDE1707 is an industrial I.P.S. (intelligent power switch). Dedicated to proximity detectors, it can deliver up to 0.5 A to a "configurable" load (load to battery or load to ground configuration); see block diagram fig.1.

On the application circuit (fig. 2) of the TDE1707 Data-Sheet, the use of filter capacitors is recommended on both :-

- The power supply (+Vs pin 7).
- The +5 V regulated voltage (Vreg pin 6).

# To understand the function of the Vreg capacitor, it is necessary to consider that the Vreg pin makes available a regulated voltage that can be used to supply external circuits (typically proximity detectors); but the TDE1707 itself, always uses the Vreg to supply most of its internal circuits (see fig.1). Internally to the TDE1707, Vreg supplies all the functional blocks, except the output power transistor (and the Driver-Led, when the Led is connected as in "load to GND. configuration").

# In the real application, the TDE1707 and associated circuitry, can be significantly far away from the power supply and the long connection wires will act as a serial inductance.

At power on, or at the turn-on of the power transistor, or in coincidence to load variations, this inductance will react to the current variations with wide voltage variations.

In proximity sensor applications, for space reasons, the size of the filtering capacitors has to be reduced as much as possible.

The voltage oscillation can induce two kind of problems in the circuit:-

- 1)Overvoltage on the +Vs pin, connected to the +24V bus, that can exceed the TDE1707 rated limit.
- 2)Disturbances inside the circuit (TDE1707), because the noise immunity level is exceeded with disruption of the input/output function.

Filtering the overvoltage on the +Vs is possible

**Figure 1:** Block Diagram

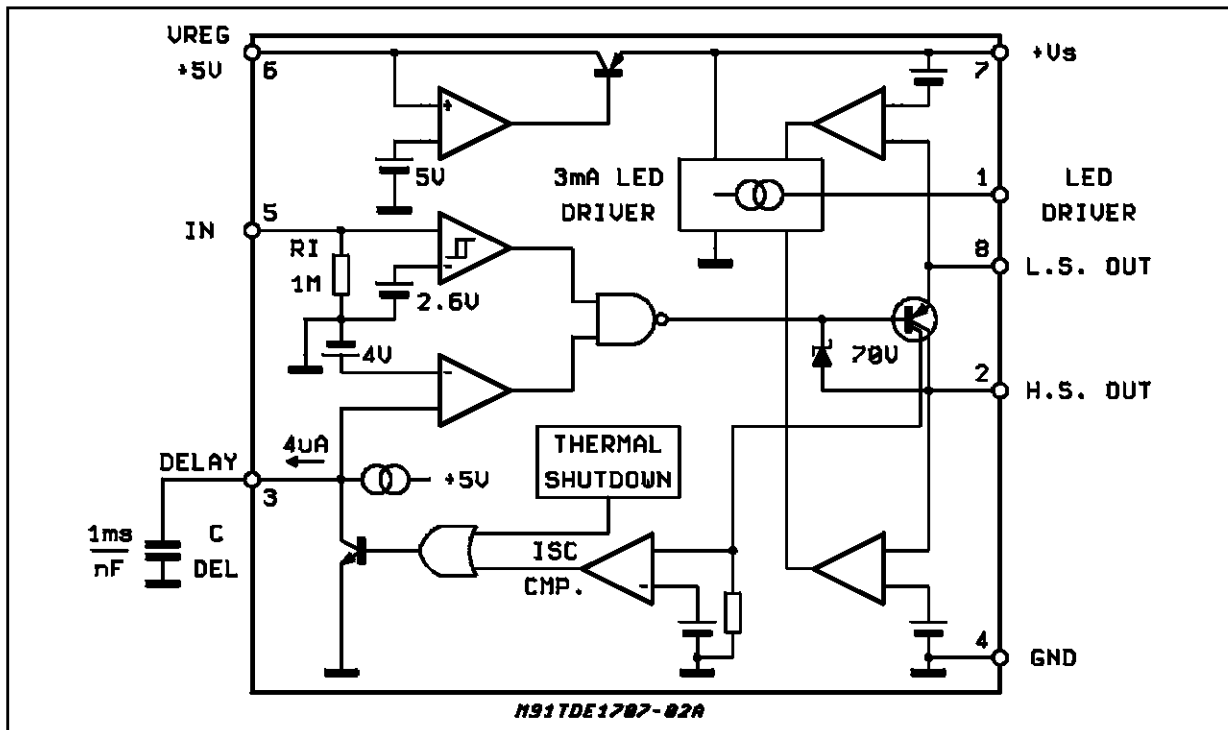

## APPLICATION NOTE

Figure 2: Application Circuit

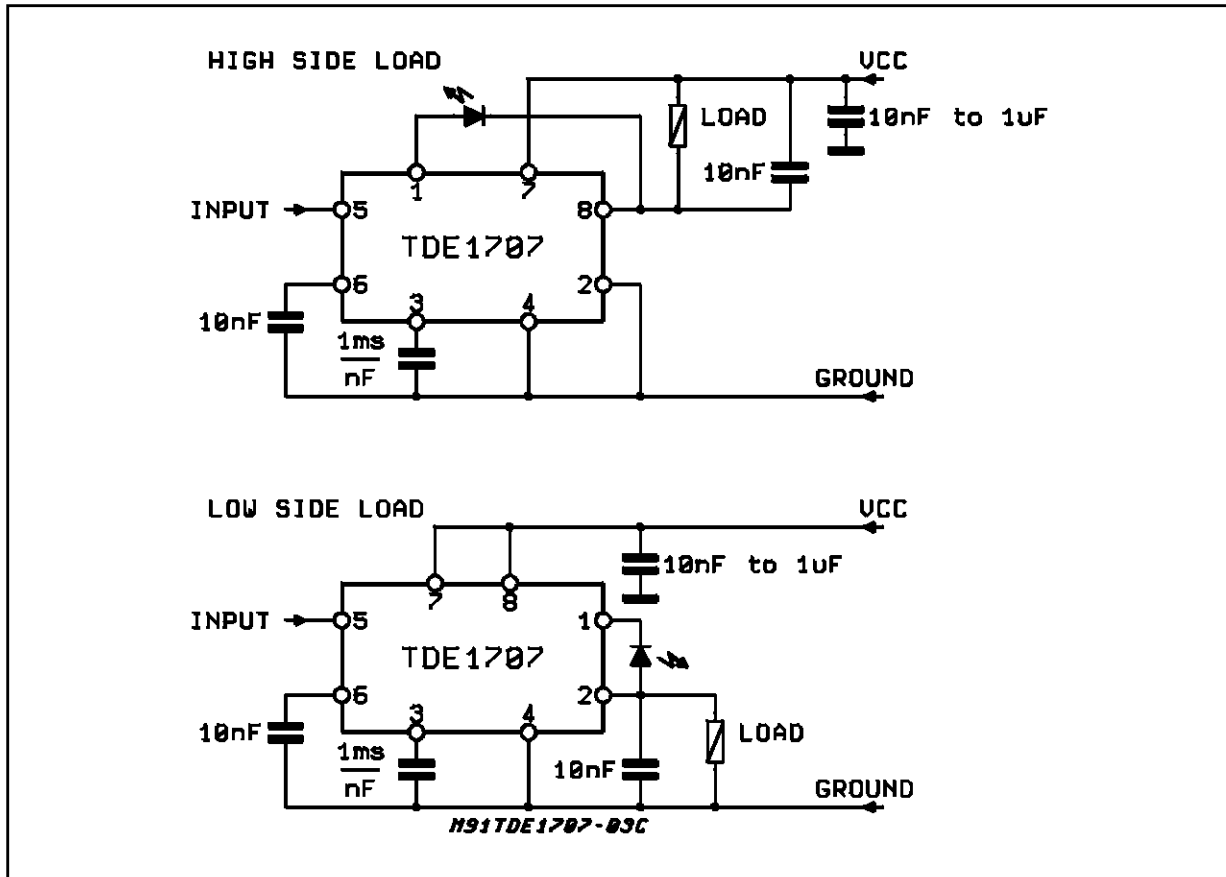

only by an external capacitance between +Vs (pin7) and Ground (pin4) to limit voltage spikes at the device's rated values.

Immunity problems in the circuit are essentially related to the +5 V Vreg filtering, because the noise on this voltage can induce errors in the low-voltage circuits.

The best solution, to avoid immunity problems, is to put the filter capacitor between Vreg and Ground even if the Vreg does not supply any external circuits. Compared to the +Vs capacitor filtering effect, that also improves the immunity, the Vreg capacitor offers two advantages:

- 1) The capacitive value can be significantly lower, for the same filtering effect, because the Vreg filter does not have to sustain the load current variations.
- 2) The nominal voltage of the capacitor is lower (6 V instead of 25-50), so that the physical size of the capacitor is also smaller.

The higher effectiveness of filtering Vreg instead of +Vs is always evident. On average, in a typical application, a capacitor put on Vreg can, with the same filtering effectiveness of a capacitor on +Vs, be 20 times smaller in value.

Nonetheless, a capacitor on +Vs, although not of

high value, is recommended. Its value shall be adapted in accordance to the equivalent inductance of the supply connections and of the value of the load.

For instance, the values used in the test circuit (fig. 3) :

- 325  $\mu$ H are too high to be found in practice.
- 4.7nF on +Vs are barely sufficient with 325  $\mu$ H (with 325 $\mu$ H, 10nF would be preferable).
- 4.7nF on Vreg are sufficient in most of the practical cases.
- Using the test circuit shown in fig. 3, with the input trigger of the TDE1707 in pulsed mode, the effect of the capacitor on Vreg (pin 6) can be noted in diagrams Fig. 4a and Fig. 4b:
  - Fig. 4a shows the voltage, on +Vs (Ch1) and Vreg (Ch2), at turn-on and turn-off edges, without the filter capacitor on pin 6.
  - Fig. 4b shows the same signals but with 4.7 nF capacitor connected between Vreg (pin 6) and Ground.

The improvement of the immunity level and the low values of the capacitors makes the suggested filtering solution the best for proximity detector application.

Figure 3: Test Circuit

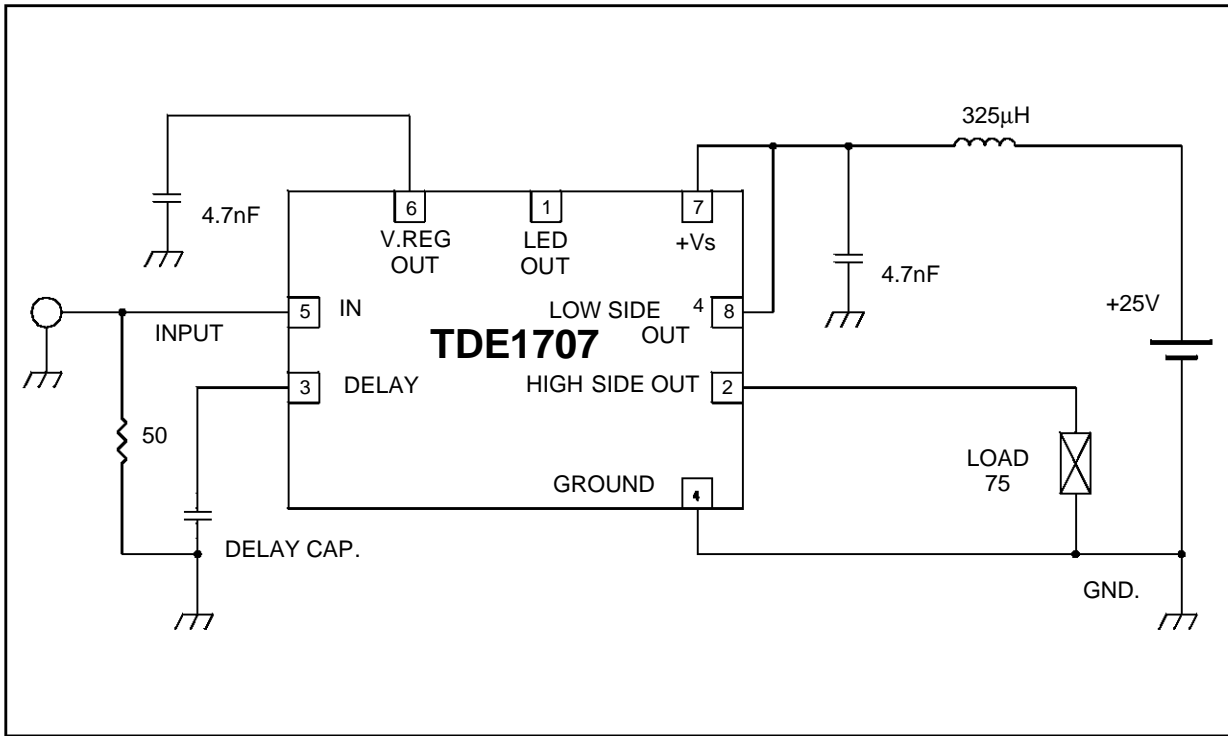
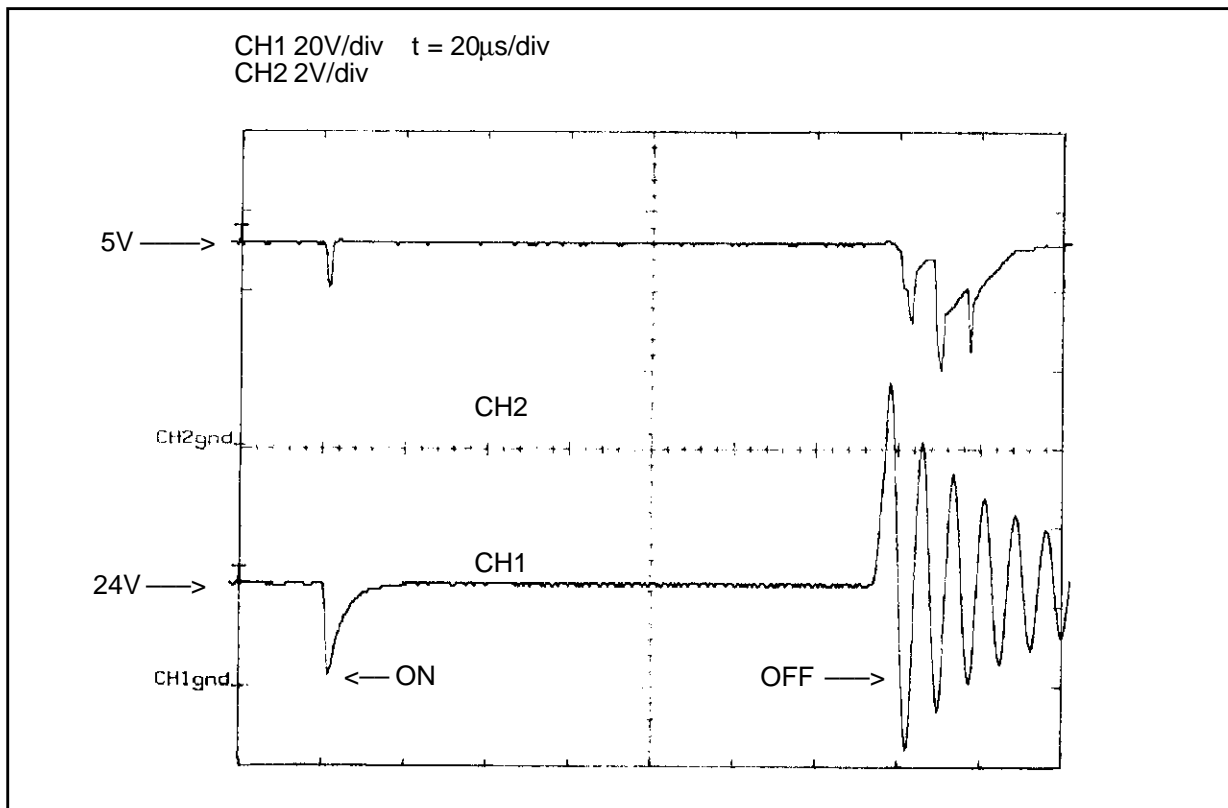
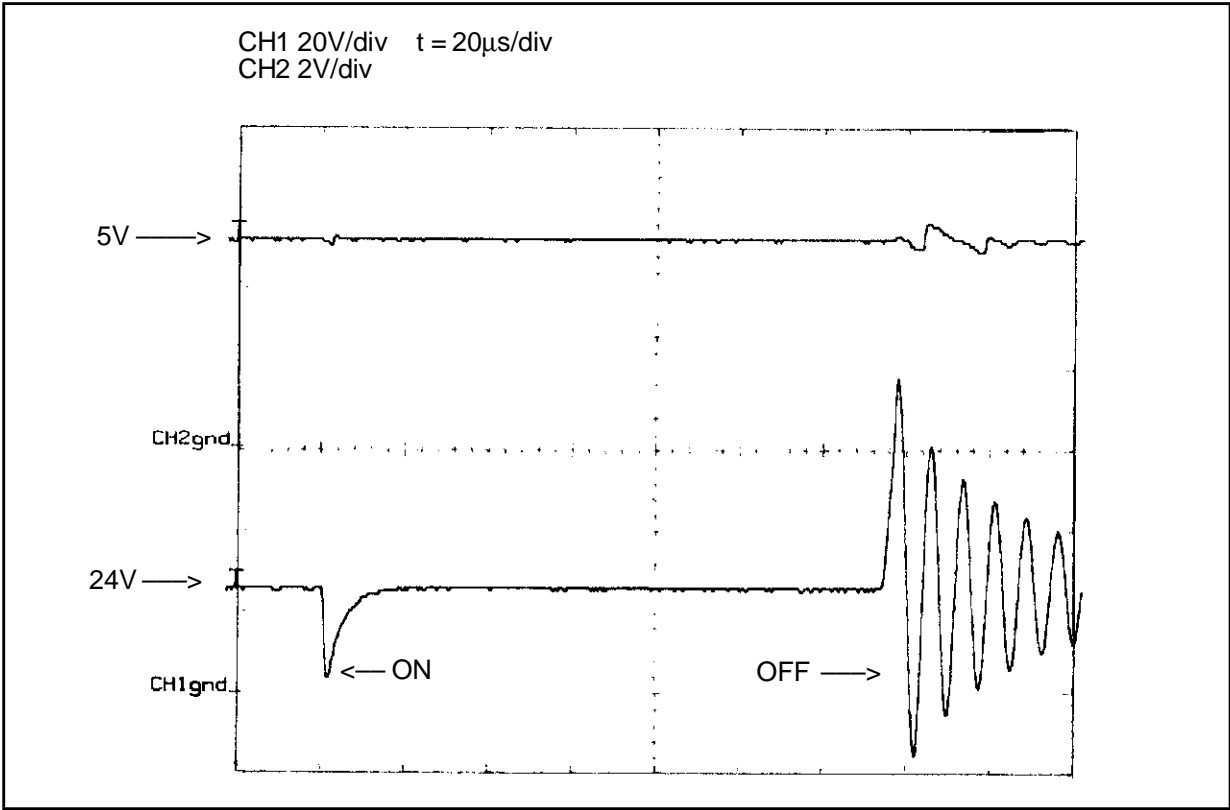

Figure 4a.



APPLICATION NOTE

Figure 4b.



Information furnished is believed to be accurate and reliable. However, SGS-THOMSON Microelectronics assumes no responsibility for the consequences of use of such information nor for any infringement of patents or other rights of third parties which may result from its use. No license is granted by implication or otherwise under any patent or patent rights of SGS-THOMSON Microelectronics. Specifications mentioned in this publication are subject to change without notice. This publication supersedes and replaces all information previously supplied. SGS-THOMSON Microelectronics products are not authorized for use as critical components in life support devices or systems without express written approval of SGS-THOMSON Microelectronics.

© 1995 SGS-THOMSON Microelectronics - All Rights Reserved

SGS-THOMSON Microelectronics GROUP OF COMPANIES

Australia - Brazil - France - Germany - Hong Kong - Italy - Japan - Korea - Malaysia - Malta - Morocco - The Netherlands - Singapore - Spain - Sweden - Switzerland - Taiwan - Thailand - United Kingdom - U.S.A.



LittleDiode supplies new, hard to find or obsolete electronic components and semiconductors all over the world.

With over two million different components listed you are sure to find the part you need.

Feel free to visit us today at our online store:

[LittleDiode.com](http://LittleDiode.com)

Looking forward to providing you with the best possible service.