

MK5025
NRZ TO NRZI CONVERSION

The SGS-Thomson MK5025 link level controller is a versatile device providing complete link level data communication control conforming to the 1984 version of CCITT X.25. The MK5025 also supports X.32 and X.75 as well as single channel LAPD for ISDN with its UI frames and extended addressing capabilities. The MK5025 also features a transparent mode of operation for implementation of customized protocols using HDLC framing.

27 and 29 - 31 (TCLK, DTR/RTS, RCLK, and TD, DSR/CTS, RD respectively). The transmit data (TD) is NRZ encoded and the receive data (RD) is NRZ decoded. To interface to other line code formats some conversion is necessary. The following figure shows one method for doing NRZ to NRZI conversion so that the MK5025 may be able to transmit and receive NRZI encoded data. It should be noted that the receive clock would typically be extracted from the received NRZI data, using a phase locked loop approach.

The MK5025 serial interface consists of pins 25 -

Figure 1: NRZ to NRZI Conversion

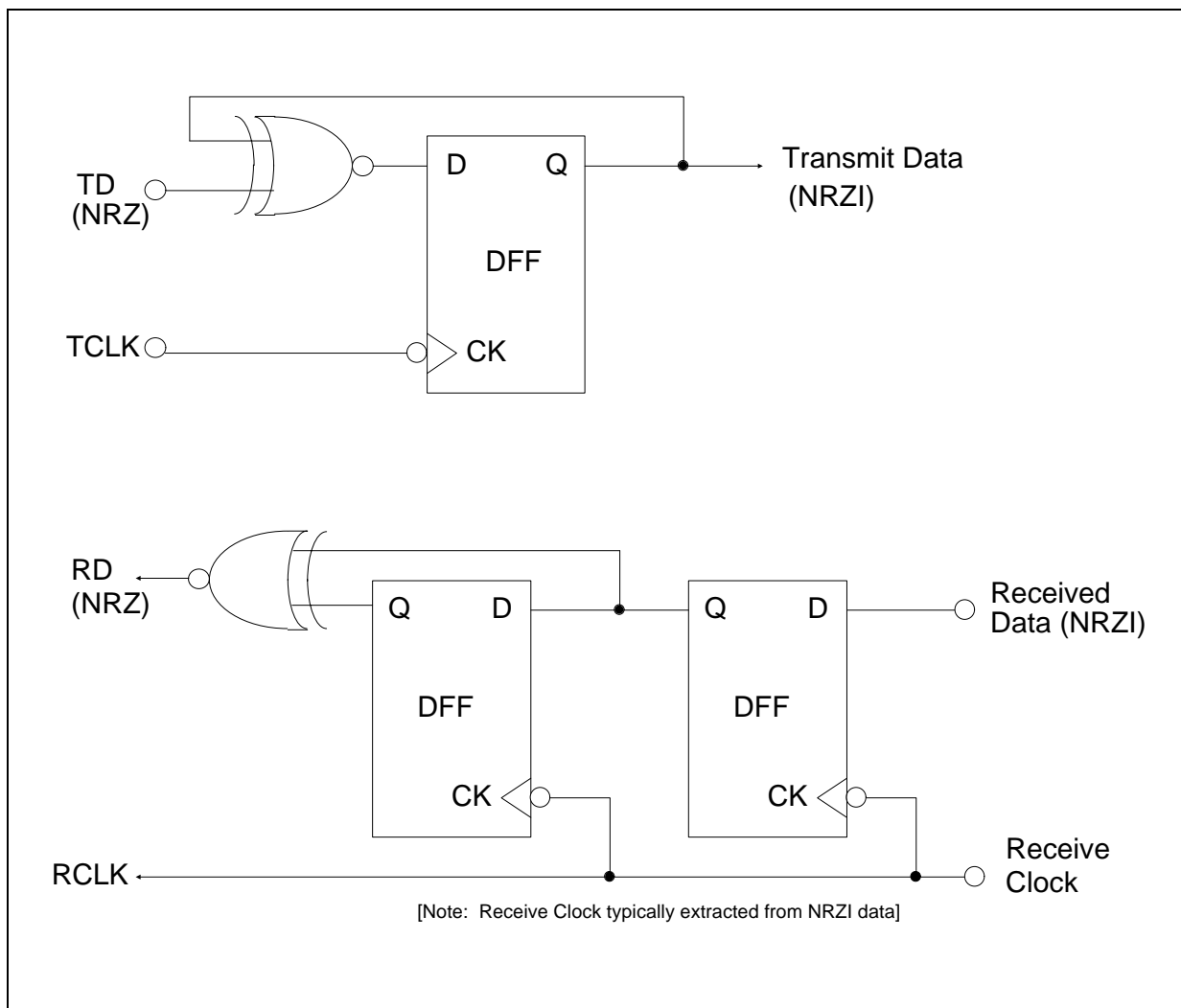

APPLICATION NOTE

Information furnished is believed to be accurate and reliable. However, SGS-THOMSON Microelectronics assumes no responsibility for the consequences of use of such information nor for any infringement of patents or other rights of third parties which may result from its use. No license is granted by implication or otherwise under any patent or patent rights of SGS-THOMSON Microelectronics. Specifications mentioned in this publication are subject to change without notice. This publication supersedes and replaces all information previously supplied. SGS-THOMSON Microelectronics products are not authorized for use as critical components in life support devices or systems without express written approval of SGS-THOMSON Microelectronics.

© 1995 SGS-THOMSON Microelectronics - All Rights Reserved

SGS-THOMSON Microelectronics GROUP OF COMPANIES

Australia - Brazil - France - Germany - Hong Kong - Italy - Japan - Korea - Malaysia - Malta - Morocco - The Netherlands - Singapore - Spain - Sweden - Switzerland - Taiwan - Thailand - United Kingdom - U.S.A.



LittleDiode supplies new, hard to find or obsolete electronic components and semiconductors all over the world.

With over two million different components listed you are sure to find the part you need.

Feel free to visit us today at our online store:

LittleDiode.com

Looking forward to providing you with the best possible service.