



Digital Audio Amplifier Gain Control using Logarithmic XICOR Digitally Controlled Potentiometers (XDCCPs)

by Applications Staff

Often the power amplifier stage of a communications device is located some distance from the control panel. The typical solution is to mount the volume control on the front panel and run a pair of shielded cables back to the power amplifier stage. A better solution is to use the Xicor X9314 logarithmic taper digitally controlled potentiometer. This completely eliminates the need for shielded cables since the digital pot can be located on the printed circuit board near the low level input stages of the power amplifier. The up/down volume switches can be located yards away as these are merely low speed TTL signals.

Circuit Description

Figure 1 shows the X9314 with the low voltage LM386 power amplifier. This circuit will produce 250mW of audio power with only a 5V DC source. Figure 2 is a similar circuit that uses the higher power LM380 and is capable of delivering over 1W of audio if a 12V DC source is available. Either circuit will provide plenty of sound for intercom, communications, or monitoring applications. The 1W circuit would be preferred when higher ambient noise is present, such as in an automobile.

A 74HC132 quad Schmitt nand gate (U2) plus a few discretes are all that are required to interface to U1, the X9314W 10KΩ XDCCP. When either pushbutton switch, S1 or S2, is depressed, U2A output will be HIGH. This immediately brings U2B output LOW which enables the XDCCP. After a short delay determined by R3 and C3, the astable multivibrator (U2C) will begin generating increment pulses. The frequency of the oscillation (and consequently the speed at which the volume can be controlled) is determined by C1 and R1. The values

shown will advance the X9314 through all 32 wiper taps in about 5 seconds. R1 can be changed from 5KΩ to 1MΩ to suit your preference. When the pushbutton switches are released, R2 and C2 delay the release of the X9314 chip select in order to ensure that the last increment pulse is written.

The X9314W needs little else to apply it to most audio circuits, but C9 has been included here to remove any DC component that may be present on the input signal. Also, lowpass filter R7 and C8 removes residual high frequency noise from the digital pots' internal charge pumps.

The LM380 and LM386 power amplifiers have fixed gains of 34dB and 26dB respectively. The gain of the LM386 can be increased to 46dB (X200) by connecting a 10uF capacitor from pins 1 to 8. The positive pole of the capacitor should be connected to pin 1. The output snubber network (R6 and C5) is required for stability and should be located close to the output pin of the power amplifier. These amplifiers have fairly high gain and wide bandwidths, so be careful with PCB trace lengths. All connections to these amplifiers should be as short and direct as possible.

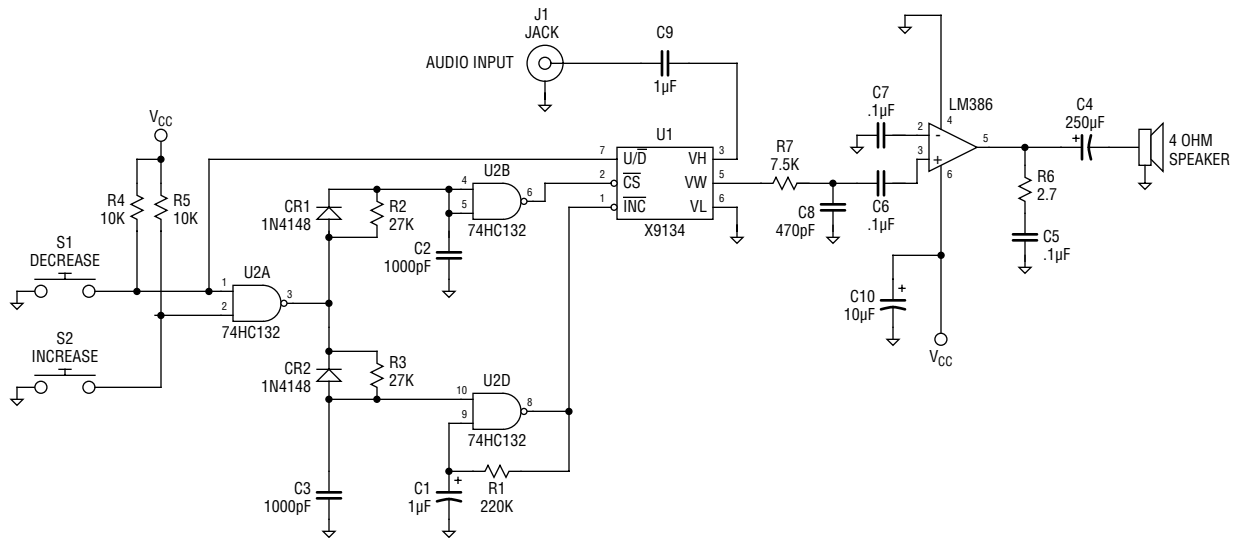

Figure 1: Low Voltage Audio Amplifier

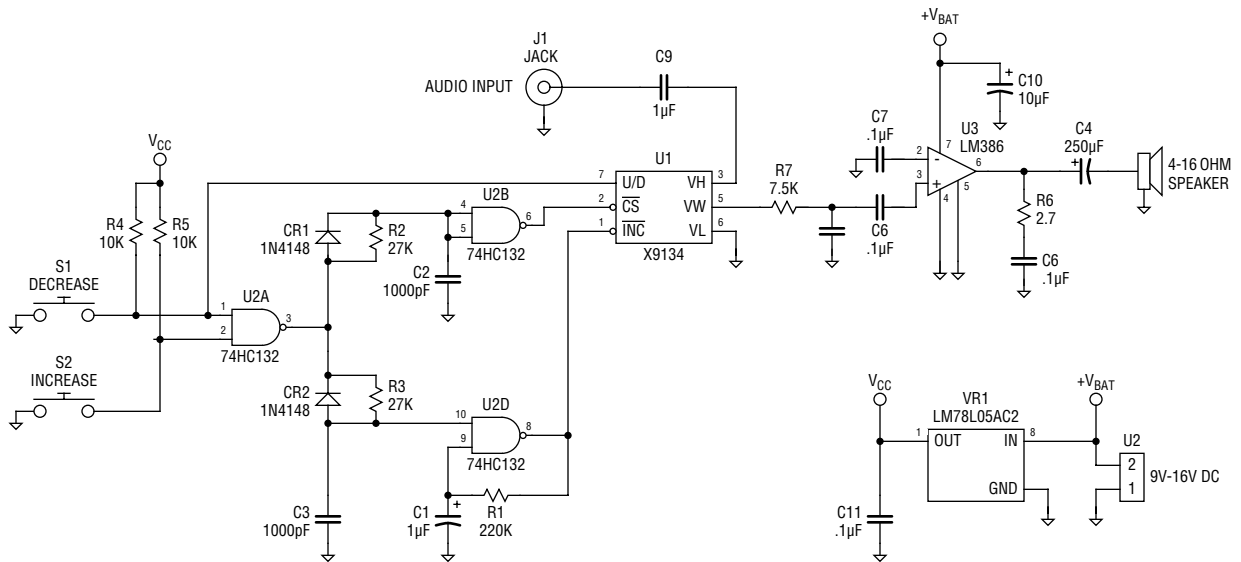

Figure 2: 1 Watt Audio Amplifier



LittleDiode supplies new, hard to find or obsolete electronic components and semiconductors all over the world.

With over two million different components listed you are sure to find the part you need.

Feel free to visit us today at our online store:

LittleDiode.com

Looking forward to providing you with the best possible service.