

**SMART POWER TECHNOLOGIES FOR  
POWERTRAIN & BODY ELECTRONICS**

by R. Ferrari

*Smart power ICs are becoming increasing by common in automotive powertrain and body electronics. This note provides a general introduction to the subject.*

As is well known, electronics is slowly but progressively invading every part of the automotive environment (figure 1); entering first in the car radio, it has extended progressively and is now present in all of the subsystems of an automobile. For those people who prefer a "historical" approach, the evolution of auto electronics has been divided into three main sections, each subdivided into various phases, correlated with the state of the art in general electronics at that time. Today, at the beginning of the 90's we are in the SMART POWER phase, and it is precisely that which we intend to discuss briefly here (see fig. 2).

We will look at, first of all, some definitions: smart power or intelligent power indicates those families of integrated circuits which include both logic control circuits and components capable of delivering a significant amount of power to a generic load. In numbers, a circuit can be considered smart power if it is able to deliver more than 0.5A to the load, or of withstanding more than 50V, or able to supply a power of at least 1W to the load.

Over the years SGS-THOMSON has developed various technologies that allow the realization of smart power circuits (figure 3). The simplest way to classify these technologies is to refer to the process type, which can be purely bipolar or mixed, that is, including on a single piece of silicon both MOS structures (of control and power) and bipolar structures. Another method (figure 4) is to examine the way in which the current flows through the power section; horizontal, with the current entering and leaving through the upper surface, or vertical, where the current enters through the upper surface and leaves through the lower surface; for this lower connection instead of wire the tie bar of the package is used.

The choice of one technology rather than another depends on various elements (figure 5) but simplifying as far as possible the criteria, we can say that vertical technologies can guarantee, for a given area, lower resistances but they have the limitation of being able to include just one power device per circuit (or more than one, but always with the collectors or drains short-circuited); while

**Figure 1:** Electronics in present and future automobiles.

| SAFETY & CONVENIENCE   | BODY CONTROL           | POWER TRAIN        | DRIVER INFORMATION    |
|------------------------|------------------------|--------------------|-----------------------|
| Rear Window Defogger   | Cruise Control         | Ignition           | Digital Gauges        |
| Climate Control        | Intermittent Wipar     | Spark Timing       | Digital Clock         |
| Keyless Entry          | Antitheft Devices      | Voltage Regulator  | Multitons Alarms      |
| Automatic Door Lock    | Electr. Suspension     | Alternator         | Engine Diagn. Results |
| Light Drimmer          | Electr. Steering       | Idle Speed control | Service Reminders     |
| Traction Control       | Multiplex Wiring       | Turbo Control      | Miles to Empty        |
| Antiskid Braking       | Module to Module       | Emission System    | Shift Indicator       |
| Window Control         | Communications         | Transmiss. Control | Head-up Display       |
| Memory Seat            | Load Sensit. Braking   | Diagnostics        | CRT Display           |
| Heasted Windshield     | Hard/Soft Ride Control |                    | Audio Annunciator     |
| Voice Controlled Trunk |                        |                    |                       |
| Airbag Restraints      |                        |                    |                       |

**APPLICATION NOTE**

**Figure 2.**

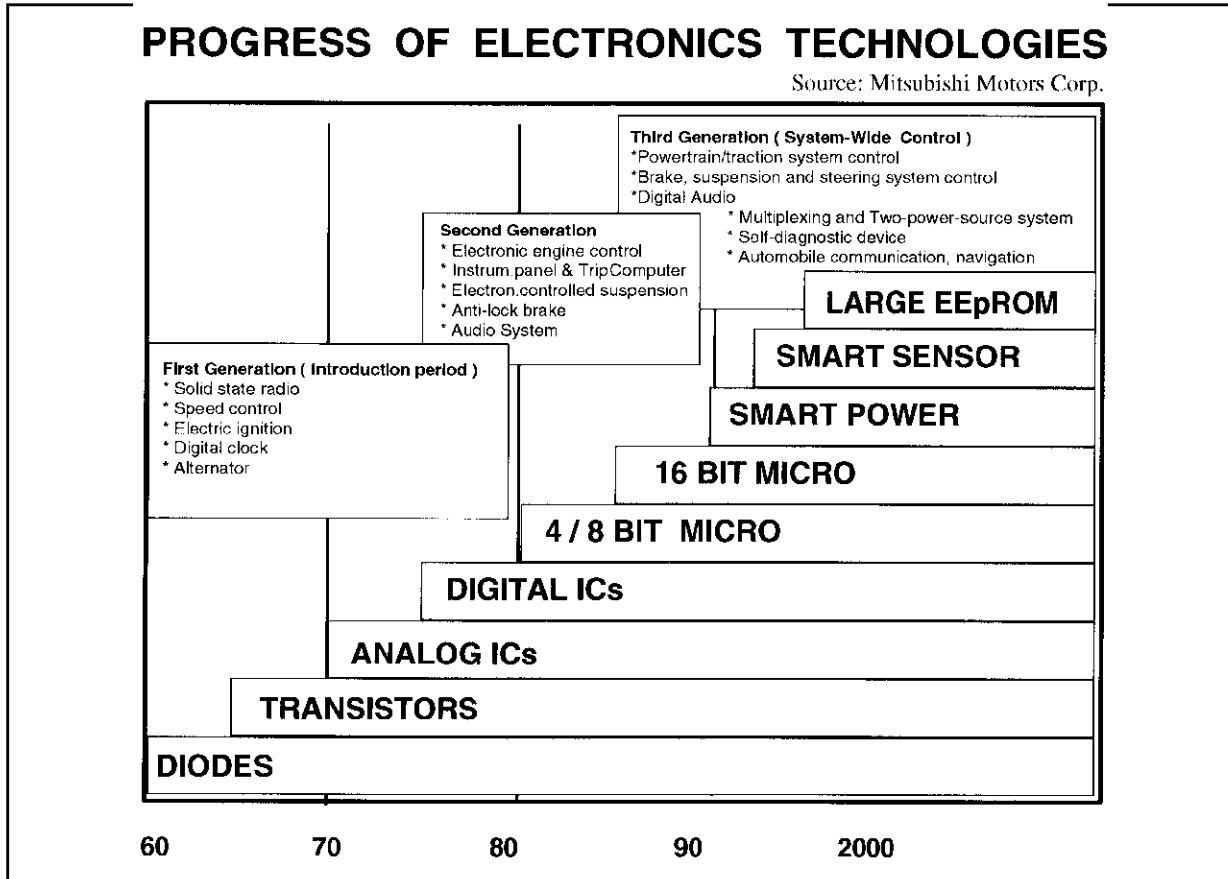

**Figure 3:** Smart Power Technologies Matrix.

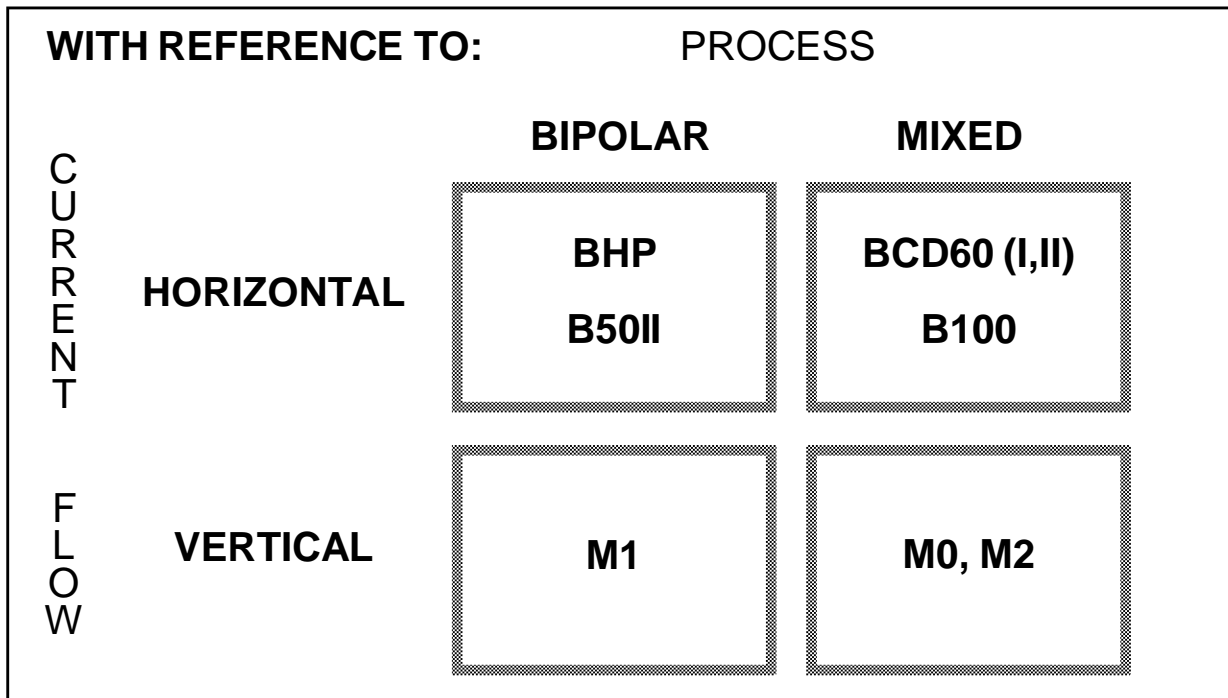
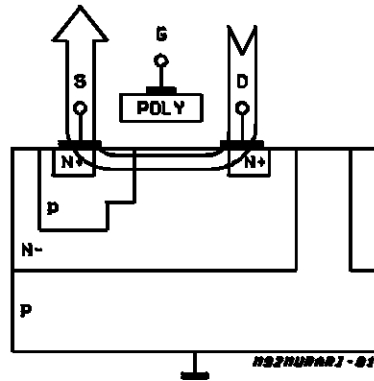
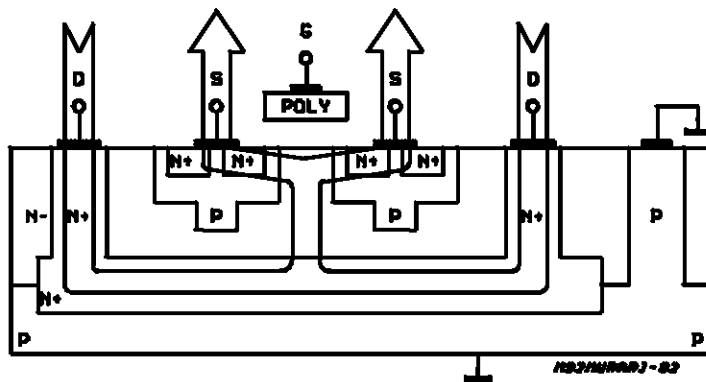

Figure 4: Integrated DMOS structures.



1 OR MORE HV LD MOS DEVICES WITH COMMON SOURCE



MANY POWER VDMOS DEVICES ANY CONFIGURATION

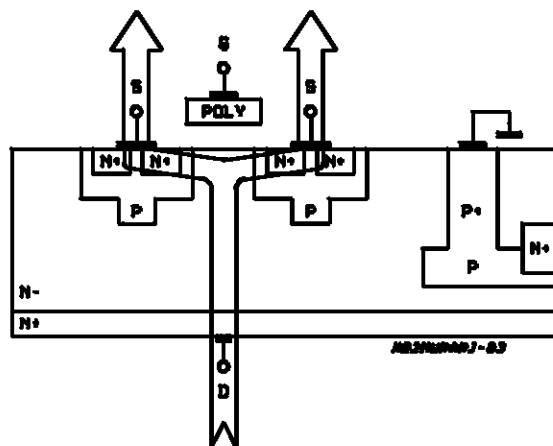

1 OR MORE HC VDMOS DEVICES WITH COMMON DRAIN

## APPLICATION NOTE

Figure 5: Smart Power Technology Matrix selection criteria.

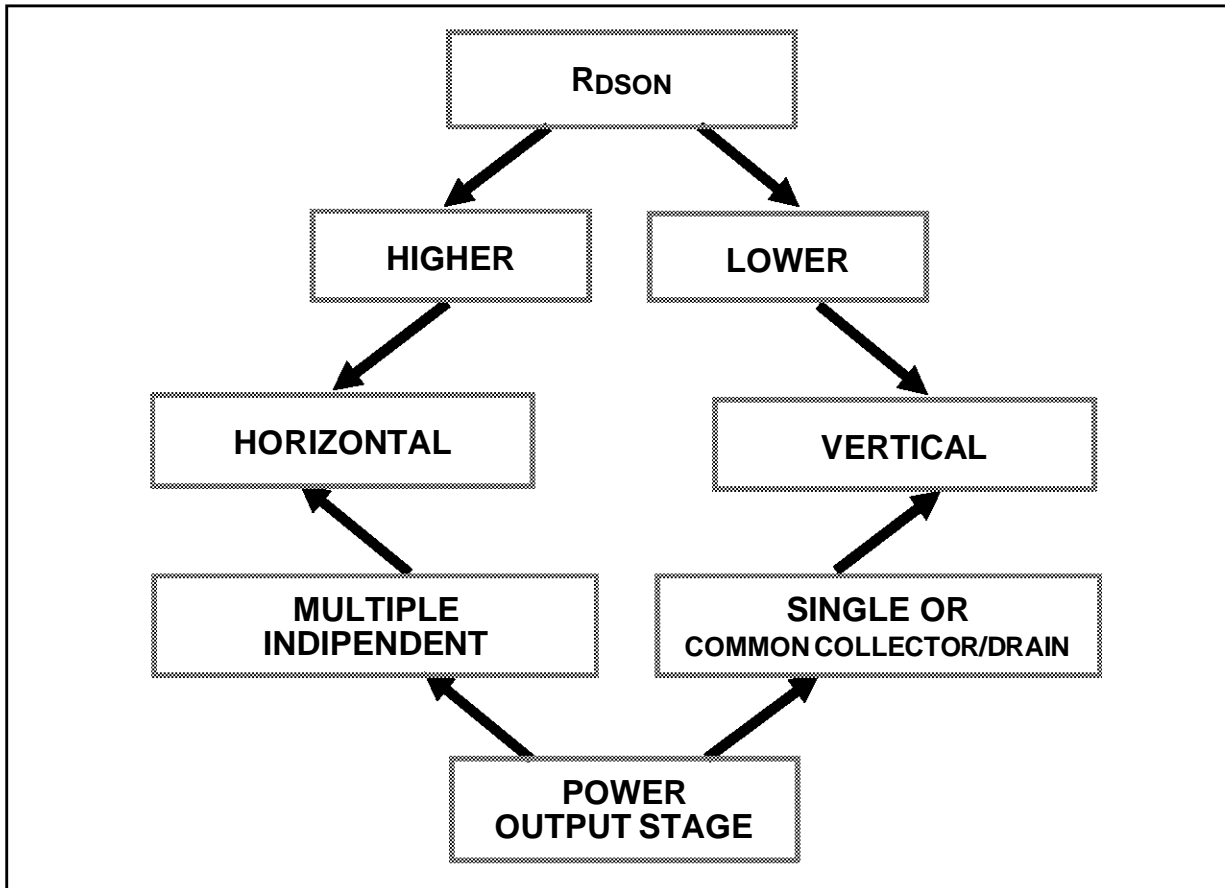
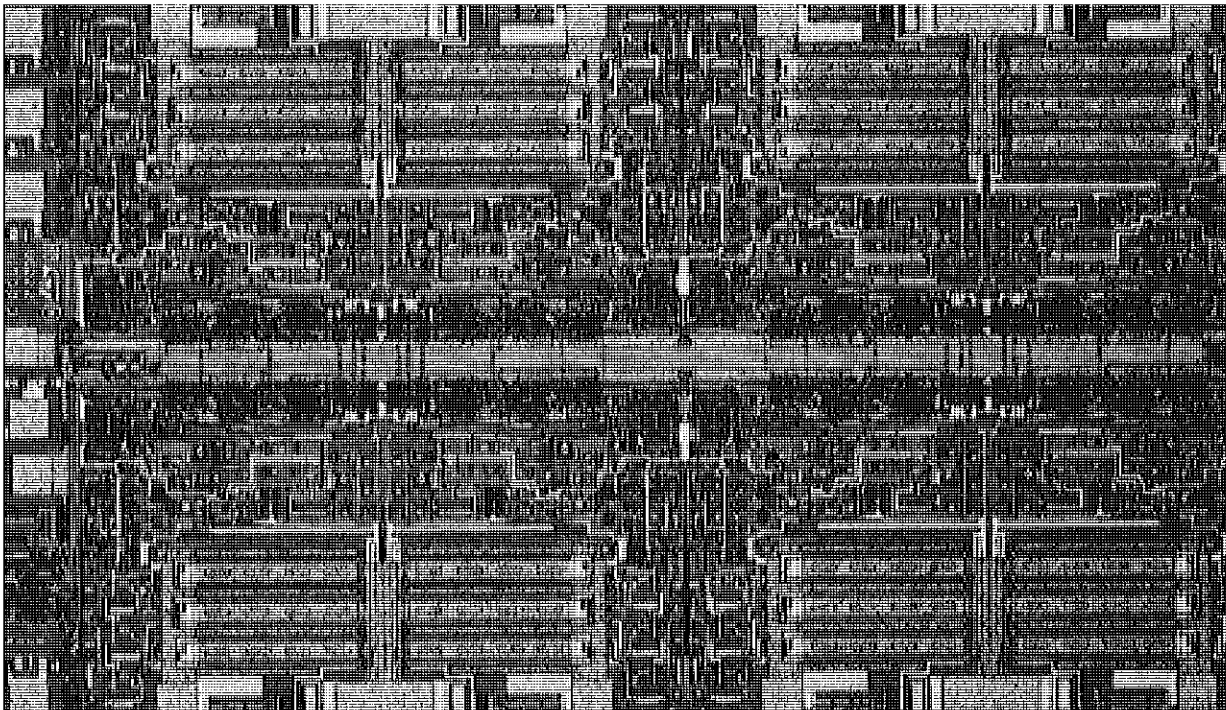

Figure 6: Multiple independent Power Structures realized with Horizontal Technology.



**Figure 7:** Bonding wire features.

| WIRE      | DIAMETER<br>(micron) | RESISTANCE<br>(mOhm/mm) | D.C. CAPABILITY<br>(Ampere)<br>in plastic<br>package |
|-----------|----------------------|-------------------------|--|
| GOLD      | 25                   | 45                      | 1.25   |
| GOLD      | 51                   | 11                      | 2.50   |
| ALUMINIUM | 178                  | 1                       | 15   |
| ALUMINIUM | 254                  | 0.5                     | 28   |
| ALUMINIUM | 381                  | 0.2                     | 43   |

horizontal technologies make it possible to have power structures that are completely independent (figure 6). It is therefore evident that a vertical technology will give excellent results in the design of a light switch, while a horizontal technology will be equally well suited to the design of a multiple actuator.

It is important at this point to underline that a smart power circuit does not consist of just silicon technology, but relies heavily on package technology. In fact it is well known that a signal device is bonded using gold wires with a diameter of 25 microns; however, gold wire can be used effectively up to diameters of 50 microns, which allows reliable operation with currents up to 2A, provided that the wire is surrounded by resin (the current capacity drops by 50% for wires in free air -- that is, in the case of hermetic packages,

When, however, one has to deal with very high

currents (more than 5A in single-point injection actuators, and more than 10A for windowlift motors) gold wires are no longer usable for obvious cost reasons so it is necessary to turn to aluminum wires (figure 7) with a diameter from 180 microns to 375 microns; clearly in this case it will be necessary to have adequately dimensioned bonding pads on the die, with a significant waste of silicon area.

Optimization is obtained with a mixed bonding technology where signal pads are bonded with thin gold wires and power pads with thick aluminum wires (figure 8). A further optimization is obtained by orienting the pads in the pad-to-bond-post direction. But while we are speaking of power it is also important to speak of packages (figure 9). These packages are part of a long tradition of TO-220 type packages (with 3, 5 and 7 pins) but recently new needs in assembly are bringing important evolutions of the classic tab

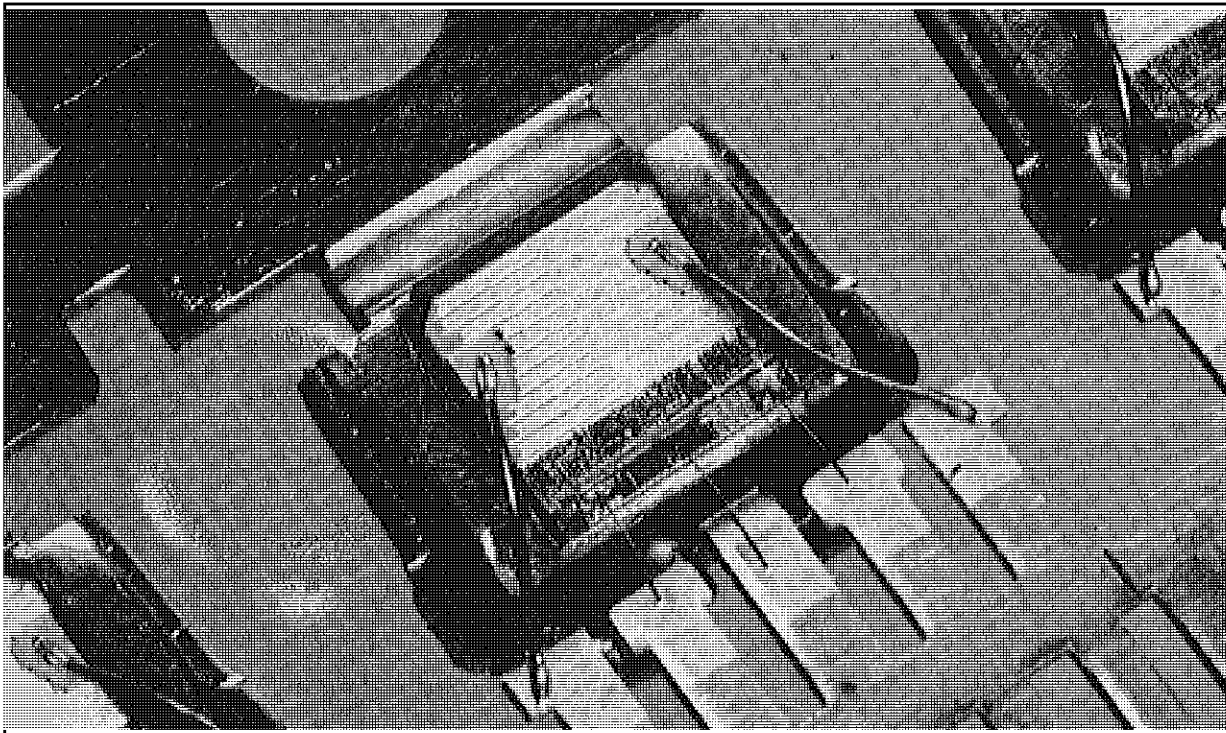
**Figure 8:** Mixed Bonding Technology.

## APPLICATION NOTE

packages. Devices completely encapsulated in completely isolated packages -- called Isowatt -- are already in production; in these devices isolation up to 1000V is obtained with a minimum reduction in the junction-to-case thermal resistance.

On the other hand, the practice of using clips, rather than screws, for mounting packages is becoming always more common, both to save space and to obtain better long-term reliability in thermal conduction. This has led to the TABLESS isolated package which accumulates the previous

two needs, while for surface mounting a non-isolated package with a junction-case thermal resistance less than 3°C/W is in development in our laboratories and will be available in industrial quantities in 1991.

Now that we have examined the means that technology places at our disposition, both in diffusion and in assembly, we can now examine what typical structures smart power processes will allow us to make, and which kind of circuit will normally be driven by each structure (figure 10).

**Figure 9:** Power package Matrix.

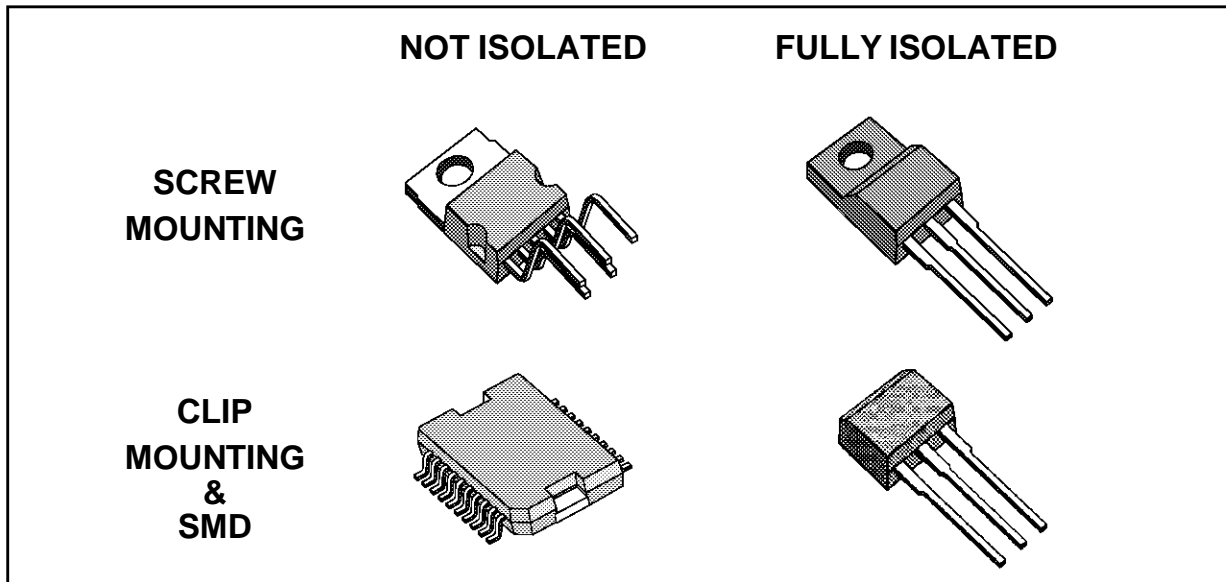

**Figure 10:** Intelligent power actuators basic configuration.

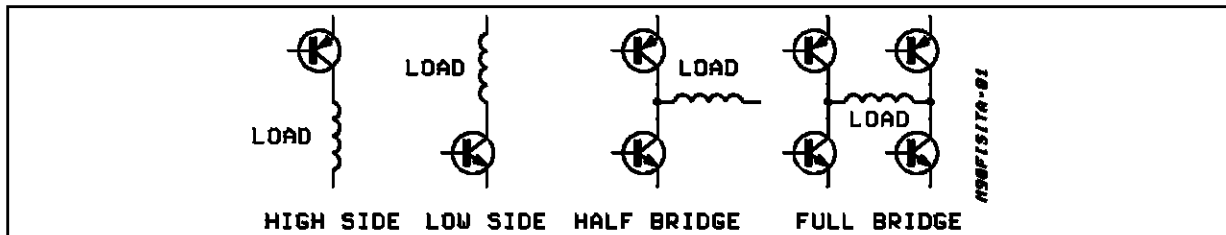

**Figure 11:** Intelligent power actuators basic protection.

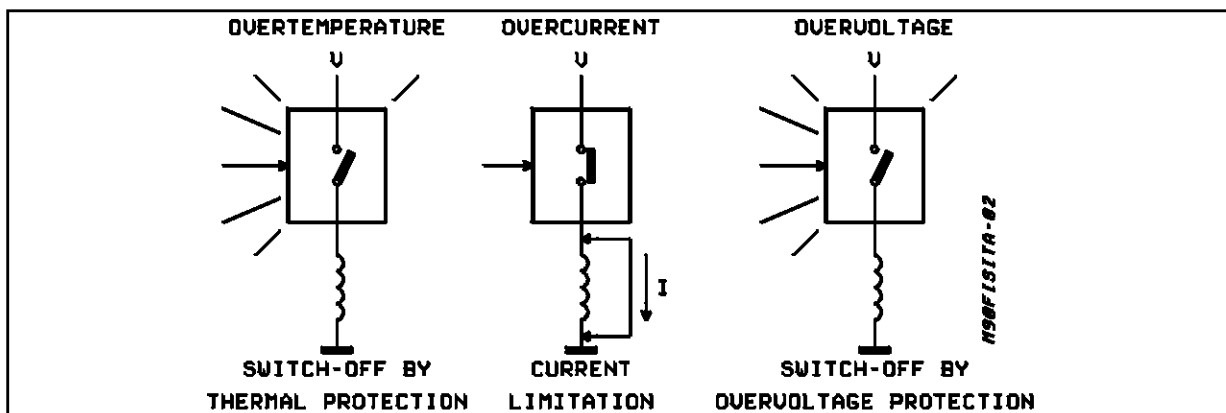

1. The typical, so-called High Side configuration, in which the actuator is located between the supply and the load, is traditionally used in the supply of resistive loads, typically lamps, but is also suitable for mono-directional motors.
2. When the actuator is between the load and the ground of the supply system we have a "low side" configuration, very common for driving inductive loads such as, for example, the solenoids that control the opening of valves (injectors, ABS system, automatic transmission), but also ignition coils.
3. Finally, when we have to drive a motor that rotates in both directions it will be necessary to use a bridge structure; the choice between integrating the whole bridge or just half of it clearly depends on the current involved. Today's technology allows us to realize efficiently a complete bridge to drive a door lock motor, while it is necessary to use two half bridges if the load is a windowlift.

In all of these structures there will always be integrated a certain number of protection circuits, to guarantee survival of the device in the presence of possible failures in the surrounding ambient

(figure 11).

These include, to name a few, the automatic shutdown when the silicon reaches a critical temperature (which can be caused not only by a short circuit in the load or its connections, but also by the degradation of thermal contact between the device and its heatsink). Today, in certain applications such as fuel injection this automatic shutdown tends to be replaced with a warning signal, which informs the control unit when a critical situation has been reached, leaving the unit itself to decide what to do (for example, reduce performance to guarantee functionality).

Another very common structure is output current limiting, even in the case of a load short circuit. Usually the intervention of the limitation circuit is accompanied by a diagnostic signal that is made available for the control system. Finally, in some devices a circuit is included that is able to detect overvoltages in the supply system, disabling the output stage and placing it in the best conditions to support the overvoltage.

Given the above, we will now describe a practical case with the aim of identifying how the design time can be optimized through a suitable interaction between the system designer and the silicon manufacturer.

The circuit shown in figure 12 is a dual low-side actuator designed to drive two independent loads

**Figure 12:** Dual 3A Low-side Actuator.

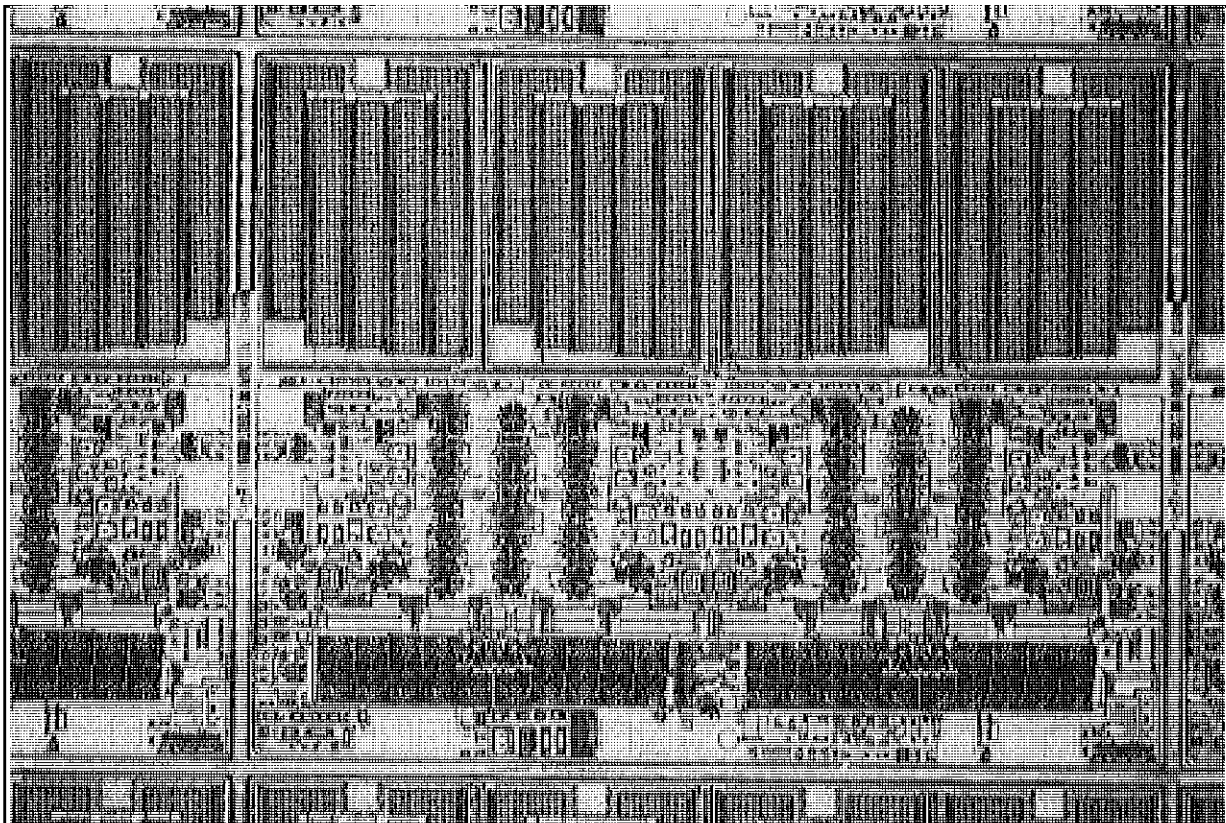

## APPLICATION NOTE

**Figure 13:** Expertise partitioning when designing a smart power actuator.

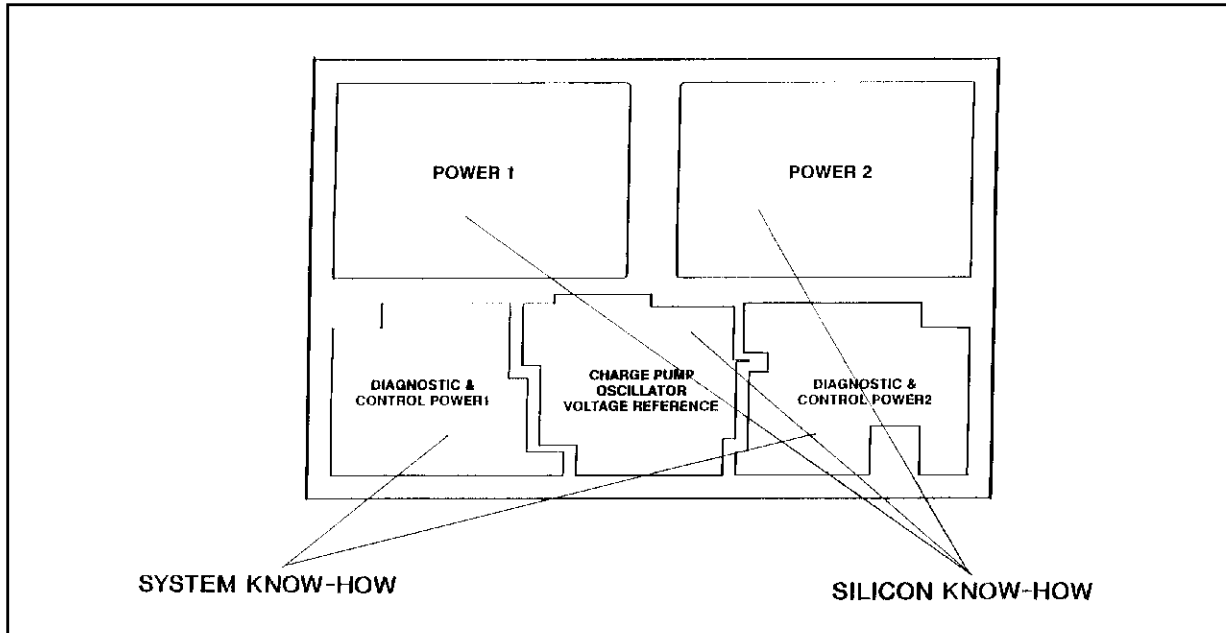

with currents up to 3A each (typically injectors). The technology employed is mixed (bipolar/CMOS/DMOS) with a horizontal current flow (BCD60); if we pass from the photograph to a topographical diagram of the silicon (figure 13) it becomes immediately evident that the chip is divided into a limited number of macroblocks, for each of which it is easy to attribute project leadership. In fact it will be an essential task of the system designers to define the criteria for the driving of the actuator as it is to define the malfunctions for which the activation of a diagnostic signal is necessary. On the other hand it is indisputable that only the silicon designer can optimize the design of the power section and take advantage of structures already available in his library to realize those functions which are necessary and also repeated frequently in different devices.

The system designer, too, can take considerable advantage from the use of cell libraries so the total design time can be reduced to a minimum (7-9 months from the start of the design to working silicon), reducing significantly the gap traditionally existing between a dedicated circuit (full custom) and a semicustom circuit obtained from gate arrays or standard cells.

A brief glance at another two circuits, each representative of a technology described above.

In the first we see a highly-innovative circuit for use in ignition systems. This is the VB020 (figure 14), a circuit realized in mixed vertical technology (M2) able to drive directly the primary of the ignition coil, combining a darlington with a vertical current flow with a driver circuit and TTL/CMOS compatible control circuit (figure 15). In the device are integrated circuits to limit the collector voltage

(fixed at 450V max).

We conclude this series of examples with the L9937 (figure 15), a bridge circuit designed to drive a door lock motor and therefore capable of delivering continuous currents of 6A with starting peaks up to 12A. The device is realized in horizontal bipolar technology and, as appears in the photograph, is almost entirely occupied by four large power transistors that constitute the output stages of the circuit. In this case, too, you can see the mixed bonding (gold for the signal wires, aluminum for power wires) and the pads oriented to optimize silicon area. In the block diagram (figure 16) you can see a chain of diodes which has the function of monitoring the temperature of the chip.

This brief introduction to smart power technologies would not be complete if it did not dedicate a few words to the price that the customer must pay to buy circuits of this type. In fact a typical question that semiconductor companies frequently hear is "How much does a square millimeter of smart power silicon cost?". Since the price of a square millimeter of silicon depends on the total area of the chip I believe that it can be a pleasant surprise to discover that even for fairly sizable chips -- that is, up to 25/6mm<sup>2</sup> -- the price of each mm<sup>2</sup> increases very little (about 25%). The curve of figure 17 gives the trend for areas between 5 and 50mm<sup>2</sup> and, though based on a theoretical calculation, follows closely the present commercial reality. Obviously the graph reflects the current state of the art; if only three years ago the elbow of the of the curve had been moved violently to the left without arriving at saying that the evolution will continue indefinitely with the same speed, it is however reasonable to expect in the next few

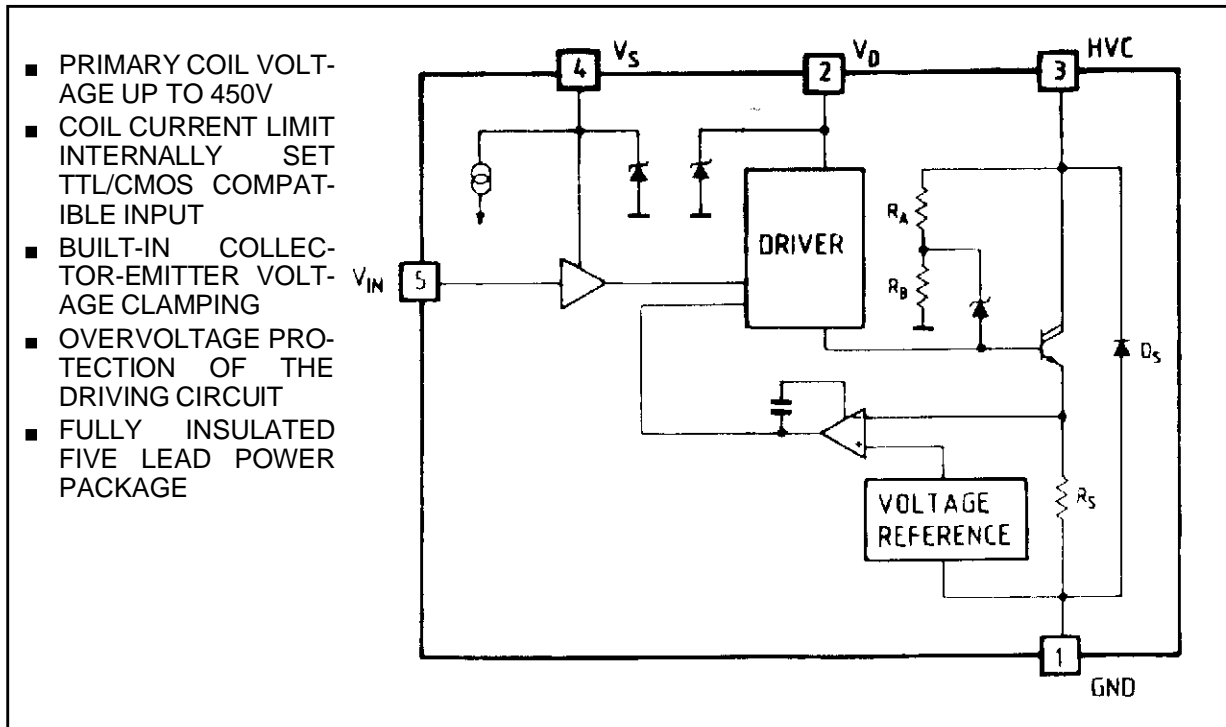
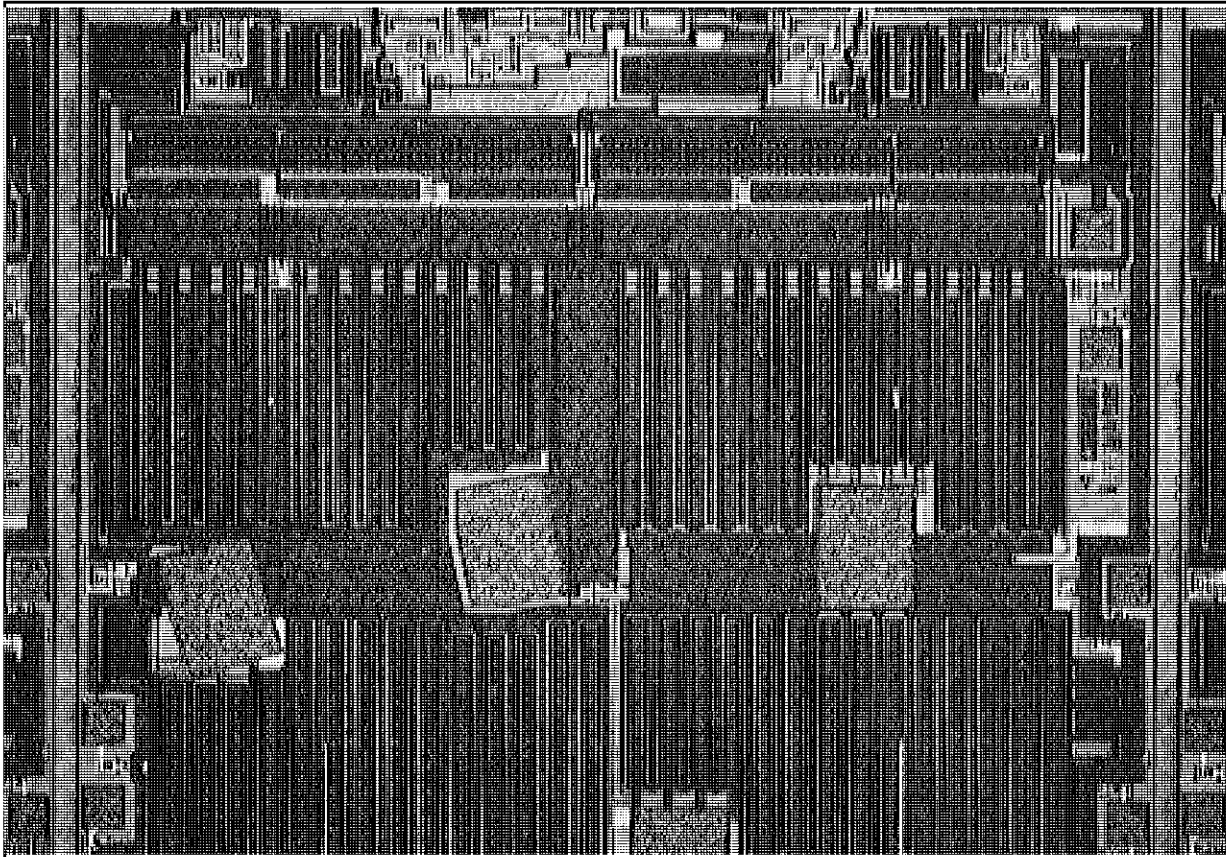
**Figure 14:** Fully integrated high voltage darlington for electronic ignition.**Figure 15:** Die of VB020.

## APPLICATION NOTE

Figure 16: Full bridge motor driver.

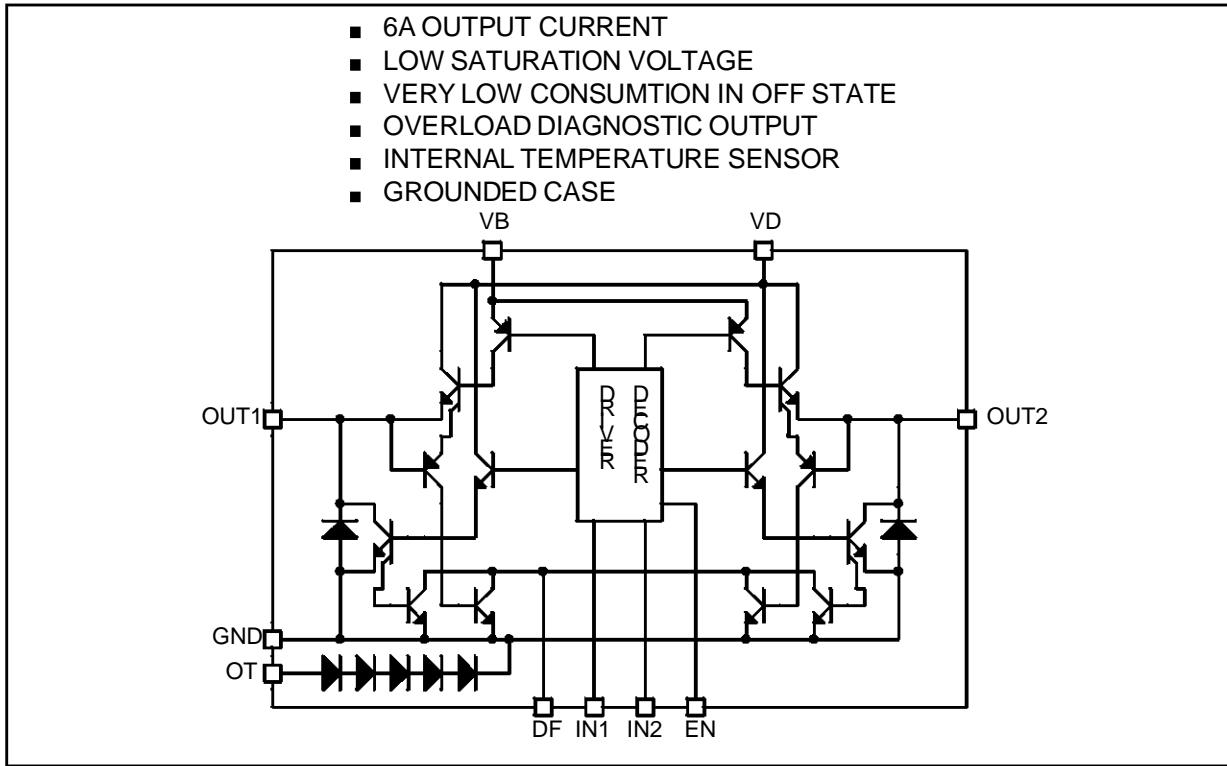

Figure 17: Smart power silicon.

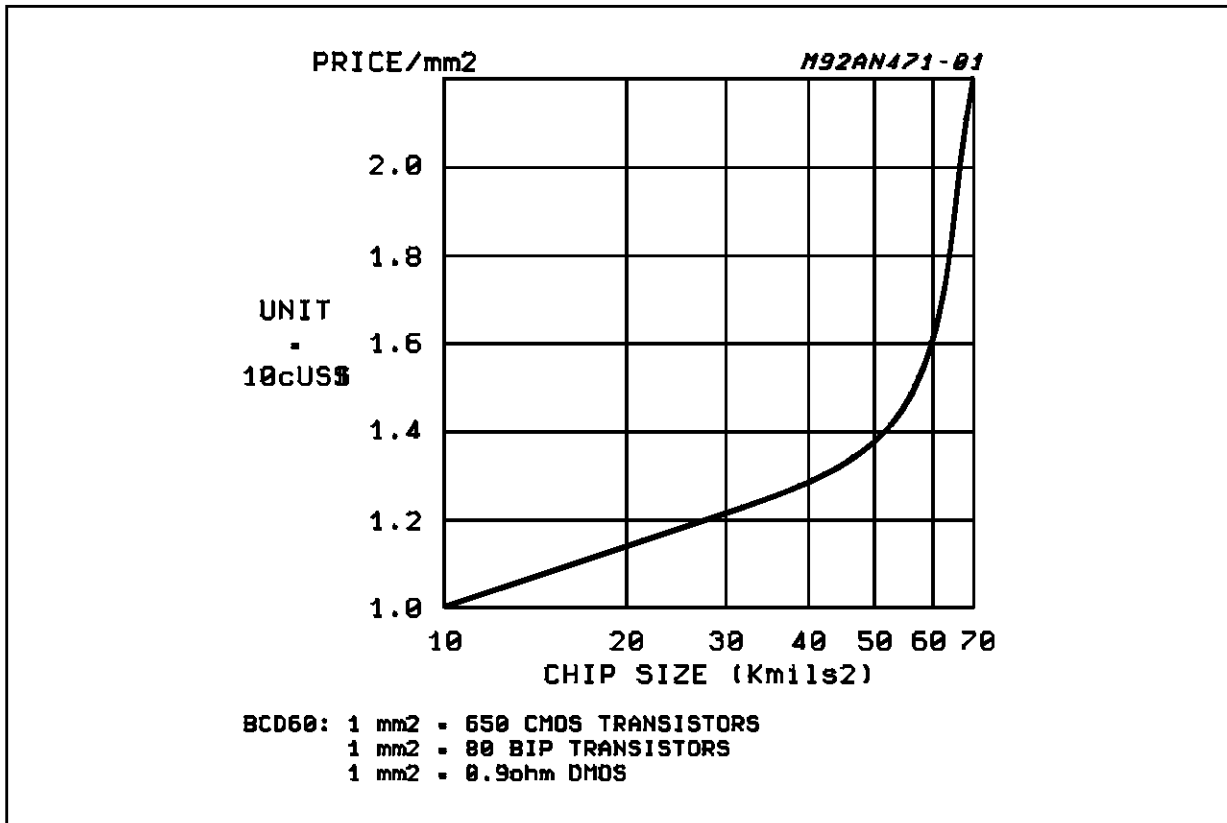
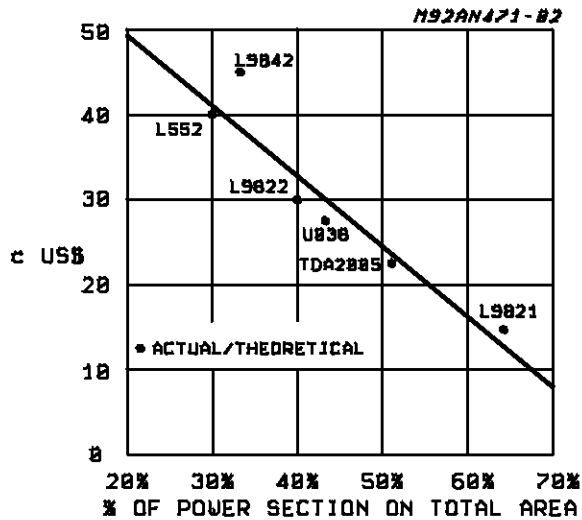

Figure 18: Smart power devices.



years a further extension of the linear zone at least towards the 40mm<sup>2</sup> region. As for the meaning of "1mm<sup>2</sup> of silicon", several possibilities are given at the foot of the table.

There is another way to evaluate the price of a smart power circuit, and this is to estimate the price for each ampere delivered to the load. This method of calculation is less rigorous and can be plotted as a graph assuming as size reference the percentage of silicon dedicated to power compared to the total area of the chip. The line shown in the figure 18 graph indicates that one ampere costs approximately 30 cents but can rise to 45 cents for circuits containing particularly complex control and diagnostic logic, and it can fall to 15 cents for devices consisting essentially of only power stages. It must be underlined that two consumer devices (L552 and TDA2005 -- both audio power amplifiers) for which we can assume stable specifications, mature technologies and ample markets, lie exactly on the curve. This should be indicative of the final trend for automotive devices which are as yet young devices in a young market.

## APPLICATION NOTE

---

Information furnished is believed to be accurate and reliable. However, SGS-THOMSON Microelectronics assumes no responsibility for the consequences of use of such information nor for any infringement of patents or other rights of third parties which may result from its use. No license is granted by implication or otherwise under any patent or patent rights of SGS-THOMSON Microelectronics. Specifications mentioned in this publication are subject to change without notice. This publication supersedes and replaces all information previously supplied. SGS-THOMSON Microelectronics products are not authorized for use as critical components in life support devices or systems without express written approval of SGS-THOMSON Microelectronics.

© 1995 SGS-THOMSON Microelectronics - All Rights Reserved

SGS-THOMSON Microelectronics GROUP OF COMPANIES

Australia - Brazil - France - Germany - Hong Kong - Italy - Japan - Korea - Malaysia - Malta - Morocco - The Netherlands - Singapore - Spain  
- Sweden - Switzerland - Taiwan - Thailand - United Kingdom - U.S.A.



LittleDiode supplies new, hard to find or obsolete electronic components and semiconductors all over the world.

With over two million different components listed you are sure to find the part you need.

Feel free to visit us today at our online store:

[LittleDiode.com](http://LittleDiode.com)

Looking forward to providing you with the best possible service.