

AN463

68HC05K0 Infra-red Remote Control

Tony Breslin,
MCU Applications Group,
Motorola Ltd., East Kilbride, Scotland

The MC68HC05K0 is a low cost, low pin count single chip microcomputer with 504 bytes of user ROM and 32 bytes of RAM. The MC68HC05K0 is a member of the 68HC05K series of devices which are available in 16-pin DIL or SOIC packages. It uses the same CPU as the other devices in the 68HC05 family and has the same instructions and registers. Additionally, the device has a 15-stage multi-function timer and 10 general purpose bi-directional I/O lines. A mask option is available for software programmable pull-downs on all of the I/O pins and four of the pins are capable of generating interrupts.

The device is ideally suited for remote-control keyboard applications because the pull-downs and the interrupt drivers on the port pins allow keyboards to be built without any external components except the keys themselves. There is no need for external pull-up or pull-down resistors, or diodes for wired-OR interrupts, as these features are already designed into the device.

This application makes use of many of the device features to control an infra-red television remote control. The application could be very easily modified to control any device with a similar transmission protocol. It will run on any of the 'K' devices without modification.

Remote Control Specifications

The basic purpose of a television remote control is to transmit a control instruction to the television. The instruction is generated by a keystroke on the remote control keyboard. The detection and decoding of a key press and the transmission encoding is carried out by the remote control micro controller.

When a key on the remote control keypad is pressed, the micro controller must first determine what key is being pressed and generate an individual code for the key. The key code is then converted to a instruction code that is inserted into the transmission command which, using a defined protocol, is transmitted to the television receiver. The command is continually transmitted as long as the key is being held down.

As the remote control is battery powered it needs to use as little power as possible. This is achieved by entering STOP mode when no keys are being pressed and effectively switches off the device. The micro controller comes out of STOP mode upon receipt of an interrupt request that is generated when a key is pressed.

Remote Control Keyboard

The 68HC05K0 has ten general purpose I/O pins. One of these is used for the transmission signal output leaving nine pins for the keyboard control. Of these, four pins on PortA have internal interrupt request hardware. Using these four pins as inputs allows key presses to be detected without any external interrupt hardware. This leaves the five remaining pins for outputs.

Using the internal pull-down facility and the rising edge interrupt request on the four inputs permits interrupts to be generated. **If the five outputs are set to logic '1', so driving an input from logic '0' to logic '1' when a key is pressed, an interrupt request can be generated.** Using this arrangement a five by four keyboard matrix can be used. An extra four keys can be controlled if the Vdd line is used to drive one row of four keys to logic '1'. Therefore the maximum amount of keys controllable becomes twenty four.



| | | | |
|-------------|--------------|-------|------|
| 1 | 2 | 3 | NORM |
| 4 | 5 | 6 | MUTE |
| 7 | 8 | 9 | VOL+ |
| 0 | PC+ | PC- | VOL- |
| TV/ TEXT | MIX | TIME | CON+ |
| STOP | SUB- PAGE | INDEX | CON- |

| | | | | |
|-----|----|----|----|----|
| VDD | 31 | 32 | 34 | 38 |
| | 11 | 12 | 13 | 00 |
| A7 | 71 | 72 | 74 | 78 |
| | 14 | 15 | 16 | 01 |
| A6 | b1 | b2 | b4 | b8 |
| | 17 | 18 | 19 | 06 |
| A5 | d1 | d2 | d4 | d8 |
| | 10 | 2c | 2d | 07 |
| A4 | e1 | e2 | e4 | e8 |
| | 39 | 3b | 3a | 0c |
| B0 | f1 | f2 | f4 | f8 |
| | 3e | 3d | 3c | 0d |
| | A0 | A1 | A2 | A3 |

Figure 1 Keyboard layout with associated scanned and transmitted codes

A depressed key will set one of the input columns to logic '1'. By scanning the columns, and setting each row output to logic '0' and then checking if the inputs all become logic '0', the associated row for the key can be determined. If rotating the logic '0' through the five output pins fails to identify a key column, then the key must be connected to the Vdd line. This process gives an individual code for each key which is a combination of the code from the column inputs and the row outputs. This can then be decoded to an instruction that is inserted into the output signal for transmission.

Figure 1 shows the layout of the keyboard on the left and the scanned and transmitted codes on the right. The keyboard layout incorporates the various television controls plus controls for TELETEXT. On the left hand side the codes returned from scanning the keyboard are shown in the upper right-hand corner of each key and the code sent for transmission for that key instruction are shown in the bottom left-hand corner. The I/O pins for each row and column are also shown for each key.

Transmission Protocol

The transmission protocol in this application is that used by the MC144105 IR Remote Control Transmitter. It uses a binary coded 9-bit data word with the LSB being transmitted first. Each bit of the transmitted signal is in the form of a bi-phase pulse code modulated (PCM) signal, whose bit coding is shown in Figure 2. For a transmitted '0' there is a 512µs pause followed by a 32kHz pulse train for 512µs. For a transmitted '1' there is 32kHz pulse train followed by a 512µs pause. This gives a bit time of 1024µs for all bits. This is shown as Figure 2.

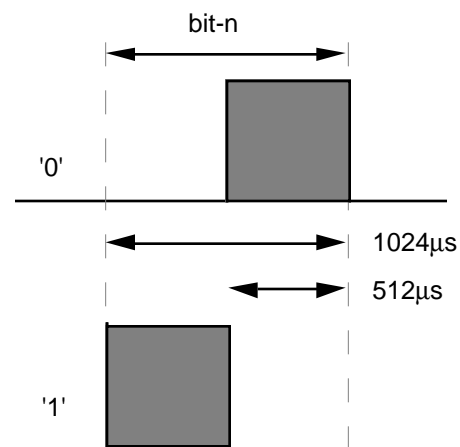

Figure 2 Bit coding of PCM signal

A complete transmission command consists of several messages. Each command begins with a start message of nine 1's followed by the message appropriate to the key pressed. This message is repeatedly transmitted until the key is released. The transmission is terminated after the key is released by an end message of nine 1's.

Every message consists of a pre-bit, a pre-bit pause, a start bit and nine data bits. The pre-bit and the start-bit are always logical '1'. The pre-bit allows for the set up of the automatic gain control in the receiving preamplifier. Figure 3 gives the exact timing relationships for the transmissions.

The command timing in Figure 3 shows that after the start transmission the message is continually re-transmitted at intervals of 131ms (approximately 8Hz) until the key is released. This is shown as time (c). The control timing shows the nine bit instruction 111001110 being transmitted starting with the LSB. The pre-bit pause is equal to two bit periods and is followed by a start-bit of logical '1'. The pulse train is continuous during the transition between transmitting a logic '0' and a logic '1'. The modulating pulse train has a frequency of approximately 32kHz with a mark-to-space ratio of one to three.

The signal for transmission is output through one port pin and is used to drive an IR diode amplifier circuit.

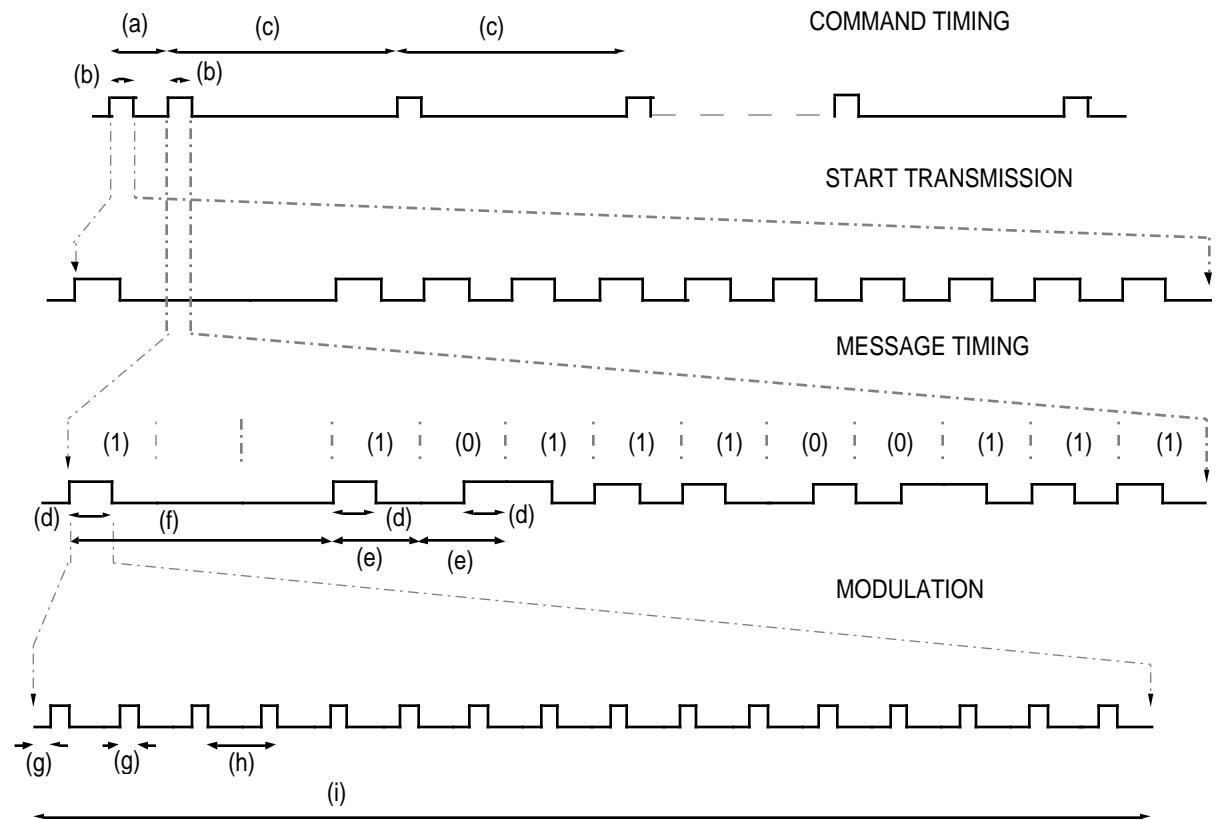

| | | | |
|----------------|---|---|-------------------------|
| Command timing | (a) = 32.8ms (b) = 13.3ms (c) = 131ms | start transmission start command control transmission | 13 * bit time |
| Message timing | (d) = 512μs (e) = 1.024ms (f) = 3.072ms | (half-bit time) (bit time) (pre-pulse time) | 16/f _{carrier} |
| Modulation | (g) = 8μs (h) = 32μs (i) = 512μs | (1/f _{carrier}) (half-bit time) | 16/f _{carrier} |

Figure 3 Circuit timing

Remote Control Operation

Figure 4 is a flow diagram showing the operation of the remote control on power-up or reset. After the initial set-up of the ports as inputs or outputs the remote control goes into STOP mode. It will remain in STOP mode as long as the device is not reset or a key is not pressed. When a key is pressed an interrupt request is generated. A short time delay makes sure that it is a true key press and not noise and also allows time for any switching effects on the inputs to pass prior to checking the inputs.

The keyboard is then read to find which key has been pressed and the code for the key is decoded into an instruction and transmitted to the television. If the key is held down the instruction is re-transmitted until the key is released. This is useful for the instructions which count through the television channels or adjust the volume, colour or brightness controls.

When the key is released a terminating instruction is sent to the receiver to inform it that the next message received is a separate instruction. This is useful in the case of a one time instruction like sending a channel number. In this example the receiver will tune to a channel only once; to tune to another channel the key must be released and a new instruction sequence received.

After terminating the transmission the ports are reset ready for the next key press and the processor returns to the STOP mode.

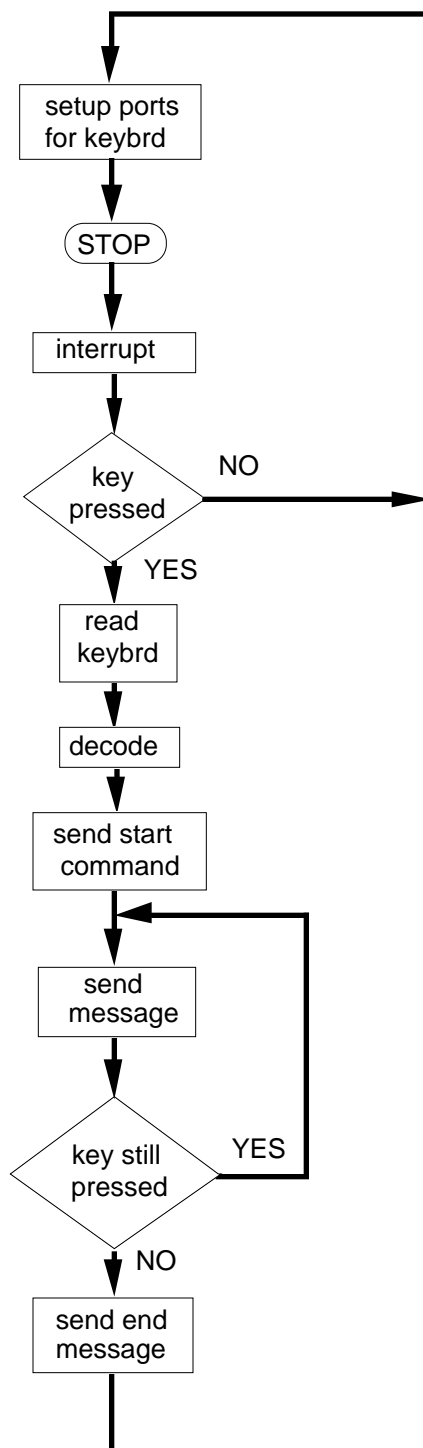

Figure 4 Flow diagram

Hardware

The remote control circuit is shown in Figure 5. The hardware consists of the keyboard, the oscillator and the infra-red amplifier. The oscillator can be a crystal or a ceramic resonator with a frequency of 2MHz. The oscillator frequency is important since the transmission timing is based around a 1MHz internal clock frequency.

The infra-red amplifier uses two transistors and two standard diodes to limit the current through the IR diodes to approximately 1A. There is a need for a large capacitor close to the IR diodes because of the high switching current of the circuit.

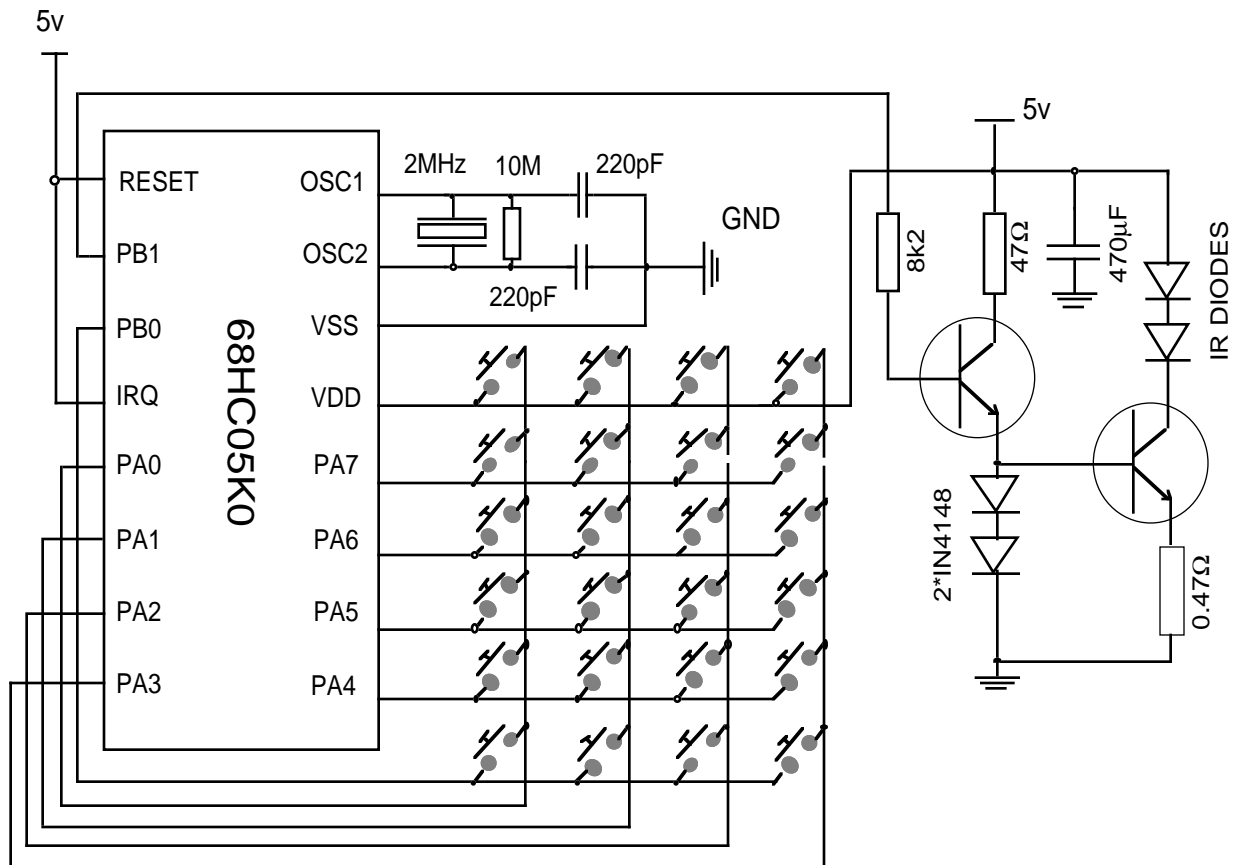

Figure 5 Infra-red remote control

Software

The listing of the remote control assembler code is contained at the end of this application note. The first section of the listing sets up the ports prior to going into STOP mode and waiting for a key to be pressed. PortA bits 0-3 are set up as inputs with the pull-downs enabled. Bits 4-7 are set up as outputs logic '1' as is PortB bit 0. PortB bit 1 is set-up as output logic '0' to switch off the IR amplifier before going into STOP mode.

The next section of code named 'presd' is the routine pointed to by the interrupt vector and is entered when a key is pressed. This routine first calls the keyboard scanning routine to determine which key has been pressed. It then calls the decoding routine to convert the code from the keyboard to a code that will be accepted by the television. The start message is then transmitted and is followed by the instruction message. There is then a check to see if the same key is still being pressed. If it is then the instruction message is re-transmitted until the key is released and the end message is transmitted.

As the transmission protocol requires nine data bits and only one byte instructions are being decoded a flag has to be set for the ninth bit of the transmission routine. For the start and end transmissions this flag is set to 1 to give the nine 1's message. For all instructions the ninth bit is 0 so the flag is cleared.

The decoding routine compares the code from the keyboard scan routine with data array 'keydat'. On a match it takes the corresponding element from the array 'tvdatt' as the instruction code for transmission.

The values of the instruction codes shown in the right-hand side of [Figure 1](#) are specific for the receiver application. Each receiver using the same communications protocol will receive the same nine bit instruction but what the instruction does is

dependent upon the receiver software. In this example the eight bit instruction '14' changes the channel to number four. In another receiver application the receiver may interpret the instruction code '14' as increase volume.

The transmission routine is entered with the instruction for transmission in 'keyst3'. After the pre-bit and the start-bit are transmitted the instruction byte is rotated (LSB first) into the carry flag. A logic '1' is sent for transmission if the flag is set after rotation and a logic '0' is sent for transmission if the flag is cleared. Each bit is transmitted as shown in [Figure 1](#). The routines 'send0' and 'send1' send a pause of 512µs followed by a 32kHz pulse train for 512µs and a 32kHz pulse train for 512µs followed by a 512µs pause respectively. In the situation when a '1' follows a '0' then a pulse train of 1024µs is required. To avoid breaks in this pulse train the 'send0' routine checks the next bit to be transmitted to see if a double length pulse train must be transmitted. The 'send1' routine then has to check that a double length pulse train has not been sent in the previous one and a half bit periods before sending a pulse train.

The routine 'burst' produces the 32kHz pulse train for a duration set by a count in the accumulator. As the instruction time for setting the PortB bit 1 pin high or low is five clock cycles then the minimum processor clock period is derived by dividing the minimum output state time, which is 8µs when the output is high, by the minimum number of clock cycles to change this state. This gives an internal clock period of $8\mu\text{s}/5$ equalling 1.6µs. Adding a three cycle delay will require an internal clock period of $8\mu\text{s}/8 = 1\mu\text{s}$, allowing a 2MHz oscillator to be used.

The code size is approximately 300 bytes, leaving memory space for more features to be added to the controller.

Debug

On applying power to the circuit the RESET vector will initialise the program counter at the beginning of the software. When examining the output at PortB bit 1 with an oscilloscope or logic analyser it should be noted that when trying to capture the

signal by pressing a key the first signal out will be the start message of nine 1's. To capture the instruction the key should be held down and as the instruction will be continually re-transmitted then the capture can be initiated at this point.

Listing

```

0026          *****
0027          * INFRA RED REMOTE CONTROL FOR K0,K1          *
0028          *****
0029          * WRITTEN BY A.BRESLIN    13.1.92          *
0030          *****
0031          * THIS PROGRAM READS AND ENCODES A KEY FROM A 24 KEY KEYBOARD *
0032          * TO A FORM OF BIPHASE PULSE CODE MODULATION (PCM) FOR INFRA *
0033          * RED TRANSMISSION. IT USES THE TRANSMISSION PROTOCOL OF THE *
0034          * MC144105 IR REMOTE CONTROL TRANSMITTER          *
0035          *****
0036
0037
0038 0000      porta    equ    00
0039 0001      portb   equ    01
0040 0004      ddra    equ    04
0041 0005      ddrb   equ    05
0042 0008      tcsr   equ    $08
0043 0010      papd   equ    $10
0044
0045 00e0          org    $e0
0046
0047 00e0      keyst1 rmb    1          ; initial code from keyboard
0048 00e1      keyst2 rmb    1          ; keycode
0049 00e2      keyst3 rmb    1          ; code transmitted
0050 00e3      dflag  rmb    1          ; flag for last and 9th bits
0051
0052
0053          *****
0054          * THE PORTS ARE SET UP USING PORTA 0-3 AS INPUTS MAKING USE *
0055          * OF THE INTERNAL INTERRUPT GENERATION ON THESE I/O LINES.  *
0056          * STOP MODE IS ENTERED UNTIL A KEY IS PRESSED          *
0057          *****
0058
0059 0200          org    $200
0060
0061 0200 9a      start  cli
0062 0201 ad 04   wpres  bsr    setup
0063 0203 9c          rsp
0064 0204 8e          stop
0065 0205 20 fa     bra    wpres
0066
0067 0207 a6 f0     setup  lda    #$f0          ; porta 0-3 inputs
0068 0209 b7 04     sta    ddra          ; 4-7 as outputs
0069 020b b7 00     sta    porta         ; set outputs high
0070 020d b7 10     sta    papd          ; 0-3 pulldown
0071 020f a6 03     lda    #$03          ; portb 0-1 outputs
0072 0211 b7 05     sta    ddrb
0073 0213 a6 01     lda    #$01          ; set portb 0 high
0074 0215 b7 01     sta    portb
0075 0217 81          rts
0076
0077

```

```

0078
0079
0080
0081
0082
0083
0084
0085
0086
0087 0218 ad 34      presd  bsr    keyscn      ; get key pressed
0088 021a b6 e1      lda     keyst2      ; save key to check
0089 021c b7 e0      sta     keyst1      ; if key held down
0090 021e ad 67      bsr    decode      ; decode key pressed
0091 0220 12 e3      bset   1,dflag     ; set ninth bit to 1
0092 0222 a6 ff      lda     #$ff        ; send start data
0093 0224 b7 e2      sta     keyst3      ; to transmission routine
0094 0226 ad 71      bsr    trnmit      ; nine one's
0095 0228 b6 e1      sndagn  lda     keyst2      ; send key press message
0096 022a b7 e2      sta     keyst3      ; byte
0097 022c 13 e3      bclr   1,dflag     ; set ninth bit to 0
0098 022e ad 69      bsr    trnmit
0099 0230 b6 00      lda     porta      ; check if key still pressed
0100 0232 a4 0f      and     #$0f        ; end if no key pressed
0101 0234 26 0f      bne    endtrn
0102 0236 ad 16      bsr    keyscn      ; else check if same
0103 0238 b6 e0      lda     keyst1      ; key pressed
0104 023a b1 e1      cmp    keyst2
0105 023c 26 07      bne    endtrn      ; end if not
0106 023e ae c8      ldx    #$c8        ; delay
0107 0240 5a      tloop  decx
0108 0241 26 fd      bne    tloop      ; transmission
0109 0243 20 e3      bra    sndagn
0110 0245 12 e3      endtrn bset   1,dflag     ; send end message
0111 0247 a6 ff      lda     #$ff        ; of nine ones
0112 0249 b7 e2      sta     keyst3
0113 024b ad 4c      bsr    trnmit
0114 024d 80      rti                ; re-enter stop mode
0115
0116
0117
0118
0119
0120
0121 024e cd 02 fc    keyscn jsr    datwt      ; wait for debounce
0122 0251 b6 00      lda     porta      ; check if key press
0123 0253 b7 e0      sta     keyst1      ; store inputs
0124 0255 a4 0f      and     #$0f        ; mask outputs
0125 0257 27 a7      beq    start      ; stop if no key pressed
0126 0259 ae ef      ldx    #$ef        ; set one row low
0127 025b 9f      nxtrow txa
0128 025c b4 e0      and     keyst1      ; combine with inputs
0129 025e b7 e1      sta     keyst2      ; store key code
0130 0260 bf 00      stx    porta      ; to find row which clears inputs
0131 0262 b6 00      lda     porta      ; check for inputs cleared
0132 0264 a4 0f      and     #$0f        ; mask outputs
0133 0266 27 1c      beq    gotit      ; zero in key-press row clears inputs
0134 0268 58      lslx
0135 0269 5c      incx
0136 026a 24 02      bcc    tryb      ; try portb output if not porta
0137 026c 20 ed      bra    nxtrow      ; try next porta output row
0138
0139 026e b6 e0      tryb  lda     keyst1
0140 0270 b7 e1      sta     keyst2
0141 0272 ae f0      ldx    #$f0
0142 0274 bf 00      stx    porta      ; set all porta outputs high
0143 0276 11 01      bclr   0,portb     ; set portb 0 output low
0144 0278 b6 00      lda     porta      ; check for inputs cleared
0145 027a a4 0f      and     #$0f        ; mask outputs
0146 027c 27 06      beq    gotit      ; zero in key-press row clears inputs
0147 027e b6 e1      lda     keyst2
0148 0280 a4 3f      and     #$3f        ; set individual code since last row
0149 0282 b7 e1      sta     keyst2      ; store code
0150 0284 10 01      gotit bset   0,portb     ; set portb column high again
0151 0286 81      rts
0152

```

```

0153
0154
0155
0156
0157
0158
0159
0160 0287 ae 18          decode   ldx     #$18           ; data array offset to zero
0161 0289 d6 03 02      nxtel   lda     keydat,x        ; look at each element of array
0162 028c b1 e1          cmp     keyst2           ; compare with key read
0163 028e 27 03          beq     match            ; decode if match
0164 0290 5a            decx                       ; else try next element
0165 0291 26 f6          bne     nxtel            ; norm if no match found
0166 0293 d6 03 1a      match   lda     tvdat,x        ; get key code
0167 0296 b7 e1          sta     keyst2           ; store code to transmit
0168 0298 81            rts
0169
0170
0171
0172
0173
0174
0175
0176 0299 10 e3          trnmit  bset    0,dflag       ; initialise for first bit
0177 029b ad 32          bsr     send1            ; send pre-bit
0178 029d cd 02 fc      jsr     datwt            ; pre-bit pause
0179 02a0 cd 02 fc      jsr     datwt            ; equalling four half data periods
0180 02a3 cd 02 fc      jsr     datwt            ;
0181 02a6 cd 02 fc      jsr     datwt            ;
0182 02a9 ad 24          bsr     send1            ; send start bit
0183 02ab ae 08          ldx     #$08             ; transmit 8 data bits
0184 02ad 34 e2          nxtbit  lsr     keyst3       ; get next bit
0185 02af 25 04          bcs     data1            ; send 1 if carry set
0186 02b1 ad 28          bsr     send0            ; send 0 if carry clear
0187 02b3 20 02          bra     bitsnt           ;
0188 02b5 ad 18          data1   bsr     send1            ;
0189 02b7 5a            bitsnt  decx                       ; countdown bits sent
0190 02b8 26 f3          bne     nxtbit           ; send next bit if count not zero
0191 02ba 03 e3 04      brclr  1,dflag,send0     ; if flag set
0192 02bd ad 10          bsr     send1            ; send 1 as ninth bit
0193 02bf 20 02          bra     endend           ;
0194 02c1 ad 18          send00 bsr     send0            ; else send 0
0195 02c3 ae 18          endend  ldx     #$18       ;
0196 02c5 ad 35          loopw   bsr     datwt            ; delay between successive
0197 02c7 ad 33          bsr     datwt            ; transmissions
0198 02c9 ad 31          bsr     datwt            ;
0199 02cb 5a            decx                       ;
0200 02cc 26 f7          bne     loopw           ;
0201 02ce 81            rts
0202
0203
0204
0205
0206
0207
0208
0209 02cf 01 e3 04      send1   brclr  0,dflag,last0 ; check if last bit was zero
0210 02d2 a6 10          lda     #$10             ; burst if last bit was 1
0211 02d4 ad 15          bsr     burst            ; 32kHz pulse for 512us
0212 02d6 ad 24          last0   bsr     datwt            ; wait 512us
0213 02d8 10 e3          bset   0,dflag           ; set flag as 1 sent
0214 02da 81            rts
0215

```

```

0216 *****
0217 * TO TRANSMIT A LOGIC '0' A 512us PAUSE IS FOLLOWED BY A *
0218 * 32kHz PULSE TRAIN FOR 512us. IF A LOGIC '1' FOLLOWS A '0' *
0219 * THE 32kHz IS CONTINUED FOR 1024us TO AVOID A PROCESSING *
0220 * DELAY *
0221 *****
0222
0223 02db ad 1f          send0  bsr      datwt          ; wait 512us
0224 02dd 00 e2 04      bsrset 0,keyst3,next1 ; check if next bit is 1
0225 02e0 a6 10          lda      #$10          ; single burst if 1
0226 02e2 20 02          bra      datset        ; data set
0227 02e4 a6 20          next1  lda      #$20          ; double burst required
0228 02e6 ad 03          datset bsr      burst        ; 32kHz pulse for 512us
0229 02e8 11 e3          bclr   0,dflag        ; clear flag as 0 sent
0230 02ea 81            rts
0231
0232 *****
0233 * THE 32kHz PULSE TRAIN HAS A MARK TO SPACE RATIO OF 1 TO 3 *
0234 *****
0235
0236 02eb 13 01          burst  bclr   1,portb        ; portb 1 low
0237 02ed 21 fe          brn      *
0238 02ef 12 01          bset   1,portb        ; portb 1 high
0239 02f1 21 fe          brn      *
0240 02f3 13 01          bclr   1,portb        ; portb 1 low
0241 02f5 9d            nop
0242 02f6 4a            deca          ; decrement count
0243 02f7 27 02          beq     endbur        ; end of burst ?
0244 02f9 20 f0          bra     burst
0245 02fb 81            endbur rts
0246
0247
0248 02fc a6 52          datwt  lda      #$52          ; count
0249 02fe 4a            loop   deca          ; to provide 512us delay
0250 02ff 26 fd          bne     loop          ; after instruction times
0251 0301 81            rts
0252
0253 0302 31 f1 e1 d1 b1 71 keydat fcb    $31,$f1,$e1,$d1,$b1,$71
0254 0308 32 f2 e2 d2 b2 72          fcb    $32,$f2,$e2,$d2,$b2,$72
0255 030e 34 f4 e4 d4 b4 74          fcb    $34,$f4,$e4,$d4,$b4,$74
0256 0314 38 f8 e8 d8 b8 78          fcb    $38,$f8,$e8,$d8,$b8,$78
0257
0258 031a 11 3e 39 10 17 14 tvdat  fcb    $11,$3e,$39,$10,$17,$14
0259 0320 12 3d 3b 2c 18 15          fcb    $12,$3d,$3b,$2c,$18,$15
0260 0326 13 3c 3a 2d 19 16          fcb    $13,$3c,$3a,$2d,$19,$16
0261 032c 00 0d 0c 07 06 01          fcb    $00,$0d,$0c,$07,$06,$01
0262
0263
0264 0332 80            softin rti
0265
0266 03fa                org     $3fa
0267
0268 03fa 02 18          fdb    presd          ; scan keybrd on int
0269 03fc 03 32          fdb    softin        ; software interrupt
0270 03fe 02 00          fdb    start         ; resett

```

All products are sold on Motorola's Terms & Conditions of Supply. In ordering a product covered by this document the Customer agrees to be bound by those Terms & Conditions and nothing contained in this document constitutes or forms part of a contract (with the exception of the contents of this Notice). A copy of Motorola's Terms & Conditions of Supply is available on request.

Motorola reserves the right to make changes without further notice to any products herein. Motorola makes no warranty, representation or guarantee regarding the suitability of its products for any particular purpose, nor does Motorola assume any liability arising out of the application or use of any product or circuit, and specifically disclaims any and all liability, including without limitation consequential or incidental damages. "Typical" parameters can and do vary in different applications. All operating parameters, including "Typicals", must be validated for each customer application by customer's technical experts. Motorola does not convey any license under its patent rights nor the rights of others. Motorola products are not designed, intended, or authorized for use as components in systems intended for surgical implant into the body, or other applications intended to support or sustain life, or for any other application in which the failure of the Motorola product could create a situation where personal injury or death may occur. Should Buyer purchase or use Motorola products for any such unintended or unauthorized application, Buyer shall indemnify and hold Motorola and its officers, employees, subsidiaries, affiliates, and distributors harmless against all claims, costs, damages, and expenses, and reasonable attorney fees arising out of, directly or indirectly, any claim of personal injury or death associated with such unintended or unauthorized use, even if such claim alleges that Motorola was negligent regarding the design or manufacture of the part. Motorola and  are registered trademarks of Motorola, Inc. Motorola, Inc. is an Equal Opportunity/Affirmative Action Employer.

The Customer should ensure that it has the most up to date version of the document by contacting its local Motorola office. This document supersedes any earlier documentation relating to the products referred to herein. The information contained in this document is current at the date of publication. It may subsequently be updated, revised or withdrawn.

Literature Distribution Centres:

EUROPE: Motorola Ltd., European Literature Centre, 88 Tanners Drive, Blakelands, Milton Keynes, MK14 5BP, England.

ASIA PACIFIC: Motorola Semiconductors (H.K.) Ltd., Silicon Harbour Center, No. 2, Dai King Street, Tai Po Industrial Estate, Tai Po, N.T., Hong Kong.

JAPAN: Nippon Motorola Ltd., 4-32-1, Nishi-Gotanda, Shinagawa-ku, Tokyo 141, Japan.

USA: Motorola Literature Distribution, P.O. Box 20912, Phoenix, Arizona 85036.



MOTOROLA



LittleDiode supplies new, hard to find or obsolete electronic components and semiconductors all over the world.

With over two million different components listed you are sure to find the part you need.

Feel free to visit us today at our online store:

LittleDiode.com

Looking forward to providing you with the best possible service.