Application Note

CDB5509 CAPTURE INTERFACE

By John Lis

INTRODUCTION

The CDB5509 evaluation board requires a simple modification to interface with the CAPTURE board. The CAPTURE board requires an SCLK input signal to collect data. However, the SCLK pin on the CS5509 is a digital input only. For the CDB5509 to interface with the CAPTURE board, an SCLK signal needs to be created.

One possible solution is to derive the SCLK from the XOUT signal. The frequency of the XOUT pin is within the specifications for the SCLK signal and the serial port can accept a continuous clock. The CAPTURE board is designed to ignore extra clock signals on the SCLK line when using a continuous serial clock.

Using XOUT as the SCLK input signal is a simple modification of the evaluation board. It is easy to implement, requiring no extra components. The following steps describe the modifications.

The source of the SCLK signal is the XOUT pin on the CS5509. Install a jumper on the CS5509 from U1-5 to U1-14. (Make sure that adjustments are made for the CAB5509 adapter board. U1-5 translates to U1-6 and U1-14 translates to U1-21 on the bottom of the evaluation board.) The 100 k Ω resistor R25 needs to be removed to reduce the load upon XOUT.

Next the 74HC125 buffer needs to be modified. U3-3 is isolated from the circuit, so there aren't two devices driving the SCLK node. Finally U3-8 is isolated, allowing U3B to be active and able to drive the SCLK output signal to the CAPTURE board. Figure 1 is a schematic for the modified evaluation board.

The following check list summarizes the modifications.

- REMOVE R25
- JUMPER U1-5 to U1-14
- ISOLATE U3-3
- ISOLATE U3-8

MODIFICATIONS TO THE CDB5509 FOR INTERFACING TO CDBCAPTURE

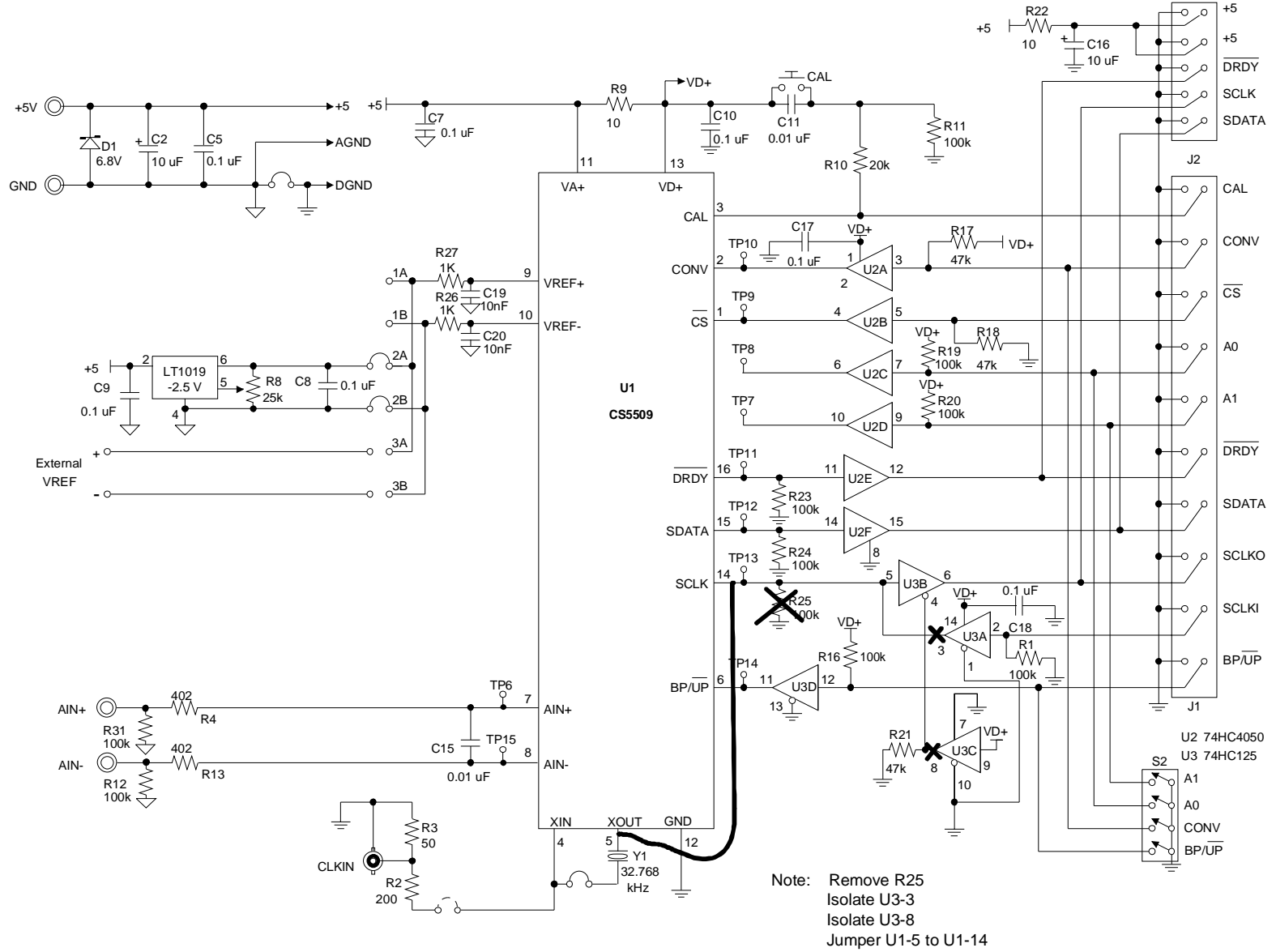

Figure 1. Schematic of CDB5509 Modified for the CAPTURE Interface



• **Notes** •

SMART
Analog™



LittleDiode supplies new, hard to find or obsolete electronic components and semiconductors all over the world.

With over two million different components listed you are sure to find the part you need.

Feel free to visit us today at our online store:

LittleDiode.com

Looking forward to providing you with the best possible service.