

VCR RECORD AND PLAYBACK HEAD AMPLIFIERS

By : J-Y. COUET

<b>SUMMARY</b>		<b>Page</b>
<b>I</b>	<b>INTRODUCTION</b> .....	2
<b>II</b>	<b>GENERAL</b> .....	2
<b>III</b>	<b>VIDEO HEAD AMPLIFIERS : Functional Analysis and Block Diagram</b> .....	3
III.1	OPERATION MODE SELECTION .....	3
III.1.a	Record / playback mode selection .....	3
III.1.b	Long play / short play selection .....	4
III.2	RECORD MODE .....	4
III.2.a	Record amplifier .....	4
III.2.b	Current limitation .....	4
III.3	PLAYBACK MODE .....	6
III.3.a	Head selection .....	6
III.3.b	Low noise preamplifier with DC offset compensator .....	6
III.3.c	Chroma output stage .....	7
III.3.d	Luma output stage with AGC .....	7
III.3.e	Tracking video information (envelope detector) .....	8
III.3.f	SP/LP envelope comparator .....	9
<b>IV</b>	<b>FM AUDIO HEAD AMPLIFIER STV5712 : Functional Analysis</b> .....	10
<b>V</b>	<b>APPLICATION NOTES</b> .....	11
V.1	PLAYBACK MODE .....	11
V.1.a	Matching up video heads characteristics with the amplifier .....	11
V.1.b	Interfacing with the VCR main board .....	12
V.2	RECORD MODE .....	13
V.2.a	Current peaking / RC damping network .....	13
V.2.b	Mixing Y and C input signals .....	14
V.2.c	Current limitation .....	14
V.3	PRINTED BOARD LAYOUT .....	14
V.3.a	Stability in playback mode .....	15
V.3.b	Gain and bandwidth in playback mode .....	16
V.3.c	Minimizing crosstalk in playback mode .....	16
V.3.d	Minimizing crosstalk : particular case of TEA5704 .....	16
V.3.e	Connecting the VCR main board .....	16
V.3.f	Stability in record mode .....	16
V.4	STV5712 ADDITIONAL COMMENTS .....	16
V.5	TYPICAL APPLICATION CIRCUITS .....	17
V.6	APPLICATION WITH A SINGLE 5V SUPPLY LINE .....	20
<b>VI</b>	<b>ANNEXE</b> .....	21

# VCR RECORD AND PLAYBACK HEAD AMPLIFIERS

## I - INTRODUCTION

This application note is intended to describe the basic operation and application of the new head amplifier integrated circuits from SGS-THOMSON, thus providing the user with the basic information required for correct implementation of these devices.

## II - GENERAL

A new complete family of high efficiency record and playback processors suitable for VHS and S-VHS home video cassette recorders has been developed by SGS-THOMSON.

This family includes devices suitable for two, three or four video heads and two HI-FI audio heads applications. The respective part numbers are TEA5702, TEA5703, TEA5704 and STV5712.

Fabricated in a high performance bipolar IC technology, a very low current and voltage noise level is guaranteed. Large bandwidth, high gain and good intermodulation of the record amplifiers is ensured by design.

Furthermore some unique functions such as automatic gain control (AGC), tracking video information (TRIV), and SP/LP envelope detection are featured in these IC's, thus producing a greater cost efficiency.

## III - VIDEO HEAD AMPLIFIERS :

Functional Analysis and Block Diagram Analysis, TEA5702/03/04

(Preliminary remark : As many of the integrated functions are common to every SGS-THOMSON video head amplifier device, the following description will universally be applicable. In the case of specific functions, the part number of the relevant circuit will be given.

The different block diagrams of the circuits are shown in Figures 1, 2 and 3.

For clarity, the functional description has been divided into 3 parts as follows :

- Operation mode selection
- Record mode
- Play back mode

Figure 1 : TEA5702 Block Diagram

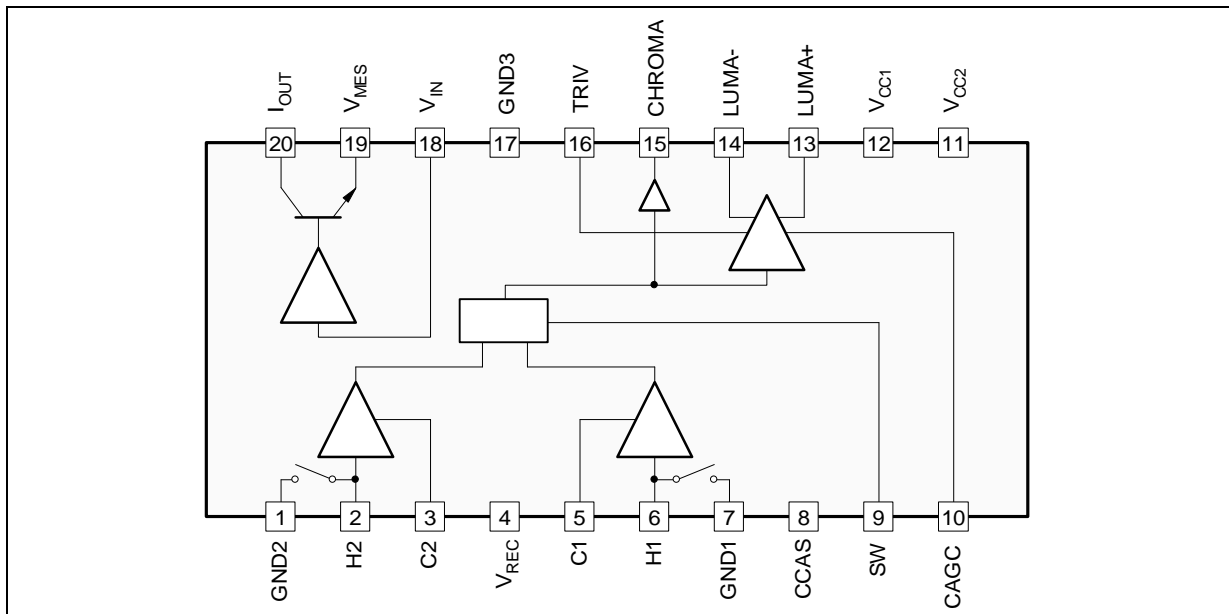

AN445-01 LEPS

Figure 2 : TEA5703 Block Diagram

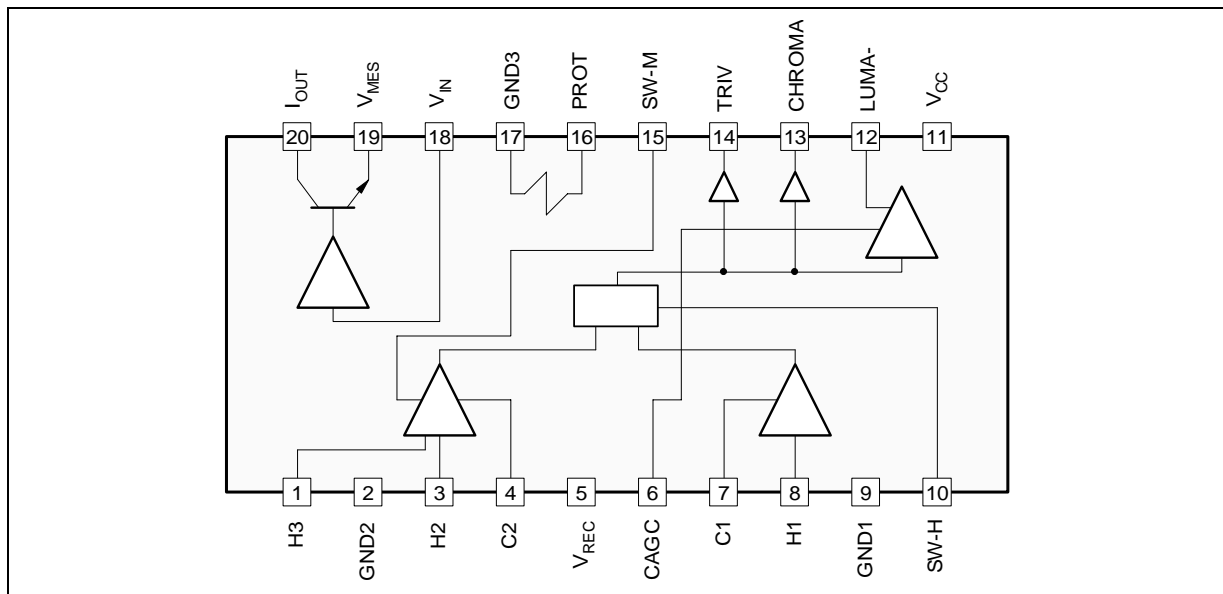

AN445-02.EPS

Figure 3 : TEA5704 Block Diagram

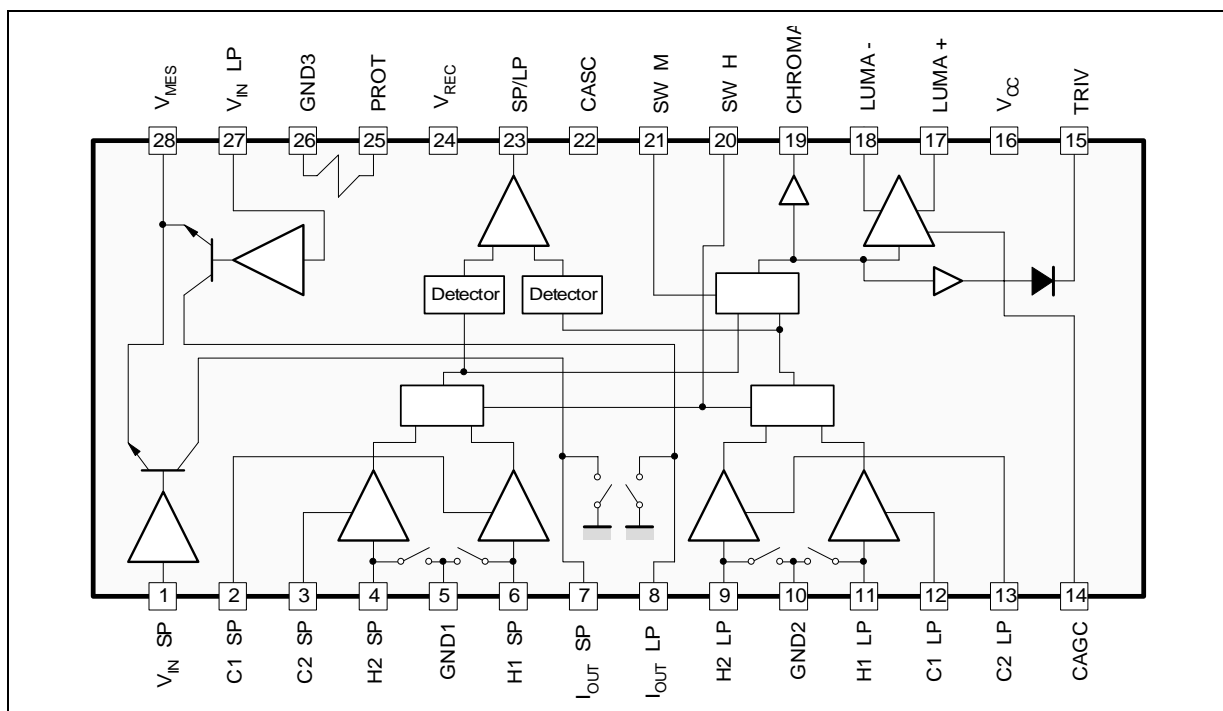

AN445-03.EPS

### III.1 - Operation Mode Selection

#### III.1.a - Record/playback mode selection

By monitoring the voltage supplied at Pin V<sub>REC</sub>, the circuits enters either the record or play back mode :

- i.e. \* V<sub>REC</sub> ≤ V<sub>TH1</sub> (typ 0.3. V) Play back mode
- \* V<sub>REC</sub> ≥ V<sub>TH1</sub> Record mode

In a typical application, V<sub>REC</sub> is 0V in the play back

mode and 5 to 12V in the record mode.

When record mode is selected, all the play back amplification channels are muted by grounding their inputs and turning off their output stages (Figure 4).

Conversely, in play back mode, the record amplifier's outputs are shunted and the corresponding output grounded (Figure 4).

Figure 4

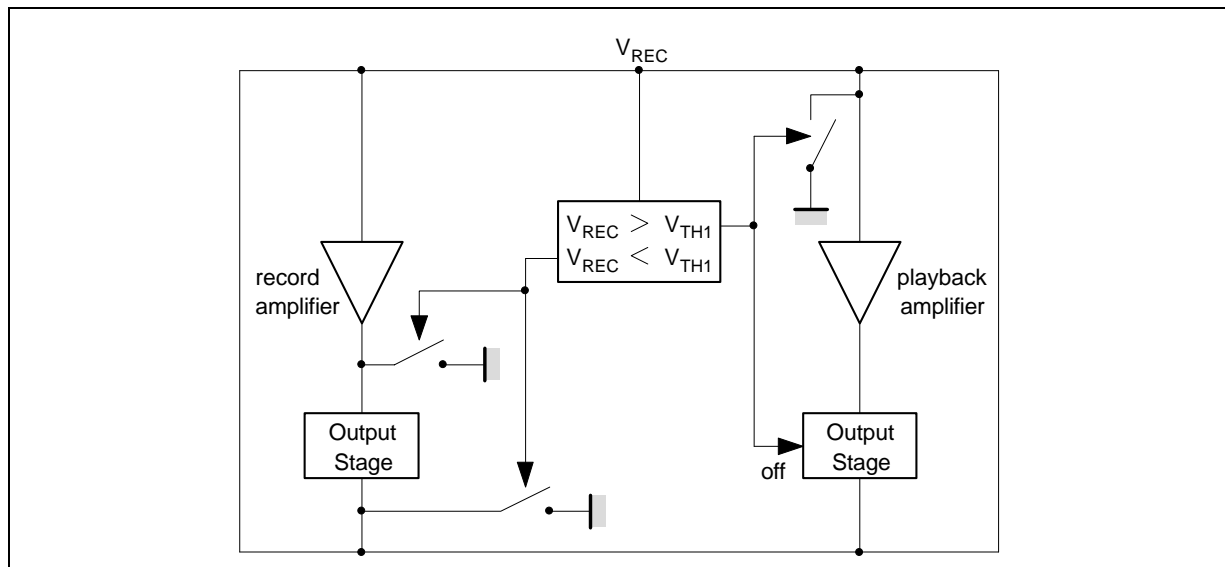

AN445-04.EPS

### III.1.b - Long play/short play selection (TEA5704 only)

In the case of 4 head circuits (TEA5704), the required head pair (SP heads or LP heads) are selected by applying a voltage at pin SW-M.

$$0V < V_{Pin\ SW-M} < 1.5V$$

$$2.4.V < V_{Pin\ SW-M} < 5V$$

In record mode, SW-M function does not only control head selection, but also turns off the record amplifiers of the not selected head pair (Figure 5).

### III.2. Record Mode Functions

The record mode functions are shown in the schematic of Figure 5. The block diagram shows two main functions per record channel :

- The record amplifier : (A)
- The current limitation circuit (C1)

Remark :

Note that the TEA5702 and TEA5703 have only one record channel, whilst the TEA5704 has 2 record channels (SP and LP).

#### III.2.a - Record amplifier

The record amplifier is a transconductance type. The input signal to be recorded  $V_I$  is directly transformed into the record current  $I_{REC}$ .

The main advantage of transconductance method

is that the record current  $I_{REC}$  remains unchanged when load impedance changes versus time (old heads) and frequency.

Assuming that the input voltage  $V_{in}$  remains almost equal to the ground level, with reference to Figure 6, the transconductance of the record channel can be calculated as follows :

$$\frac{I_{REC}}{V_I} \cong \frac{R_F + R_M}{R_{IN} \times R_M}$$

Remark : Due to an internal compensation circuit, the resistance  $R_P$  ( $\cong 1\Omega$ ) of the current limitation circuit has a negligible influence on the record channel transconductance value.

#### III.2.b - Current limitation (TEA5703/04 only)

A current limitation circuit is implemented to protect both the head and the integrated circuit against any damage occurring when  $R_M$  is short circuited.

With reference to Figure 5, the current flowing in the Record channel through the head and across the amplifier output induces a voltage drop at resistance  $R_p$ . When this voltage drop reaches the level  $V_P$  (0.27V typ.), both the input and output stages of the record amplifier are turned off. Therefore limiting the current runaway. (In the case of a permanent short circuit, the current may oscillate, this phenomena is acceptable).



# VCR RECORD AND PLAYBACK HEAD AMPLIFIERS

## III.3 - Playback Mode

In this mode the following functions are active.

- head selection circuitry
- low noise preamplifier with DC offset compensation
- chroma output stage
- luma output stage with AGC
- TRIV (Tracking information video) or Envelope Detector
- SP/LP envelope comparator (TEA 5704 only)

### III.3.a - Head selection

Based on basic analog switch cells, the head selection function is accessible through both the SW-H and SW-M pins.

This function is detailed in the truth tables shown below :

* TEA5702		
Normal Mode	$V_{SW-H} \leq 1.5V$	Head 2 active
	$V_{SW-H} \geq 2.4V$	Head 1 active
* TEA5703		
Normal Mode	$V_{SW-H} \leq 1.5V$	Head 2 active
	$V_{SW-H} \geq 2.4V$	Head 1 active
Still Picture Mode	$V_{SW-M} \leq 1.5V$	Head 3 active
	$V_{SW-M} \geq 2.4V$	Head 1 active

### \* TEA5704

The SW-H and SW-M inputs permit head selection from 4 possibilities (H1SP / H2SP / H1LP / H2LP).

To have compatibility with the SP/LP function (in fast and slow SEARCH MODES), the head allocation must be performed as shown in Figure 7, whereby H1SP/H1LP have the same azimuth, and H2SP/H2LP have the opposite azimuth.

Figure 7

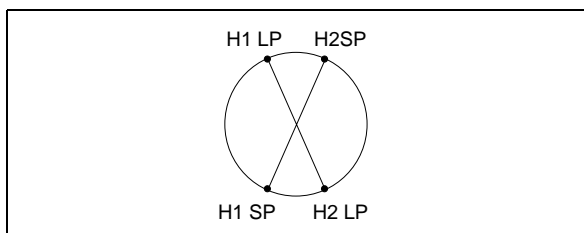

AN445-07.EPS

## Truth table

$V_{SW-M}$	$V_{SW-H}$	Selected Head
$\leq 1.5V$	$\leq 1.5V$	H2 SP
	$\geq 2.4V$	H1 SP
$\geq 2.4V$	$\leq 1.5V$	H1 LP
	$\geq 2.4V$	H2 LP

### III.3.b - Low noise preamplifier with DC offset compensation

Considering the playback preamplifier, the noise characteristics are a key parameter.

To fulfil this low noise requirement, while maintaining a wide band width (> 8MHz) and high gain (60dB typ.), particular care has been taken in designing this function.

Also included in the preamplifier section is a DC compensation circuit performing an output DC voltage change of less than 50 mV when switching from one head to another. Therefore, the frame frequency modulation characteristics are greatly improved (see Figure 8).

With reference to the Figure 9 each channel can be described as following :

The first stage G1 of the preamplifier works with an internally fixed closed loop in order to feature a fixed input impedance.

eg : TEA5704  $R_{IN} \cong 600\Omega$   
 $C_{IN} \cong 30pF$

Additional amplification is provided by G2, giving a total amplification of 60dB. The resulting signal is fed back to a transconductance amplifier OC. This signal charges or discharges an external capacitor C with a current proportional to the DC offset between the differential outputs of G2 (e+ and e-). Thus the DC level at the inverting input of G2, varies in such a way as to minimize as much as possible for the output DC offset between e+ and e-.

Moreover as the switch circuitry used after the preamp section is only sensitive to the differential mode, then the DC offset compensation will be maintained until the output stage.

Figure 8 : Output Voltage with Reduced Frame Frequency DC Offset

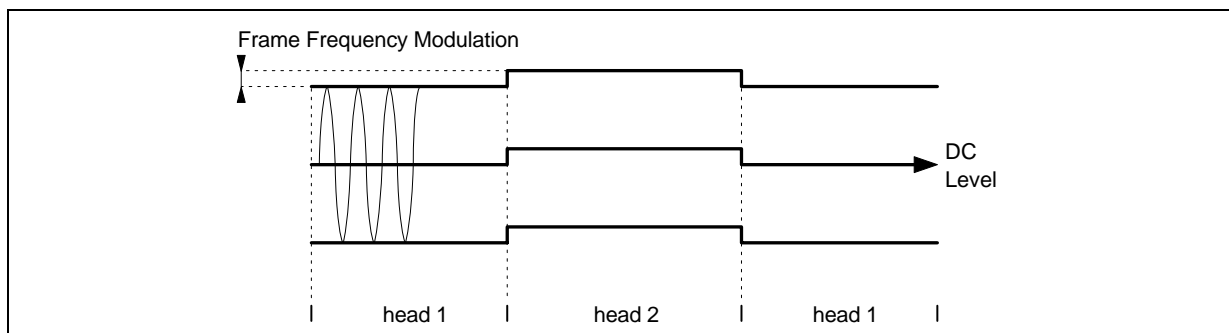

AN445-08.EPS

Figure 9 : Preamplification Section, Simplified Block Diagram

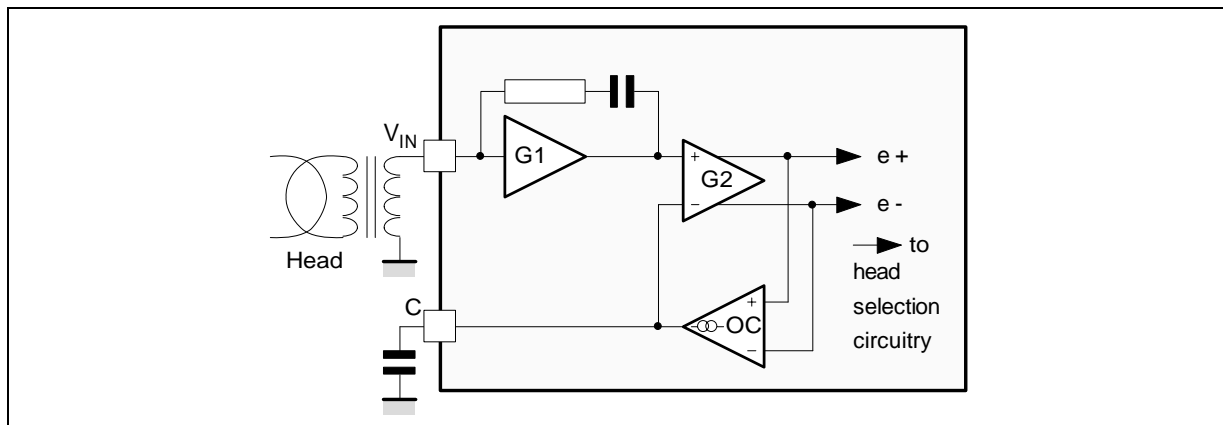

AN445-09.EPS

**III.3.c - Chroma output stage**

Like the luma output stage, the chroma output stage has an emitter follower structure. The purpose is simply to provide an impedance conversion to match the external circuitry.

The chroma output stage does not feature AGC function.

The chroma and luma- output signals have the same phase.

The output signal of the multiplier M has 2 components : a DC component proportional to the square of the amplitude of the luma output signal, and an AC component with a frequency of twice that of the luma signal.

The required DC component is extracted by a low pass filter ( $f_c = 0.36\text{MHz}$ ), and compared with a voltage reference (G5 amplifier). The resulting voltage across capacitor  $C_{cag}$  controls the gain of amplifier G4.

**III.3.d - Luma output stage with AGC**

A constant signal level (typ 200mV<sub>PP</sub>) is delivered to the luma outputs due to the automatical gain control (AGC) circuitry.

The core of the AGC block consists of an analog multiplier M which receives the luma+ and luma- output signals. A high pass filter ( $f_i = 1.3\text{MHz}$ ) on each input rejects the amplitude modulated chroma signal (Figure 10).

Remark : In order to reduce the response time ( $C_{cag}$  capacitor charging time) when switching, the heads. The voltage swing at Pin Ccag is limited between  $\frac{V_{CC}}{2} + 2 V_{BE}$  and  $\frac{V_{CC}}{2} - 2 V_{BE}$

Remark : the TEA 5703 luma+ output is not externally available.

Figure 10 : Output Stages and AGC Function

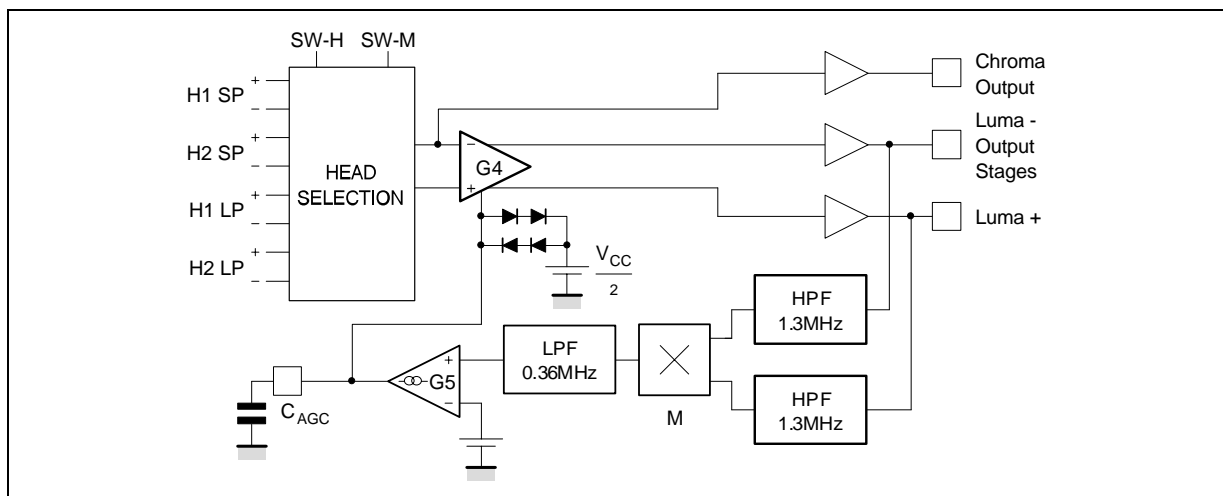

AN445-10.EPS

## VCR RECORD AND PLAYBACK HEAD AMPLIFIERS

### III.3.e - Tracking video information (TRIV)

#### Principle :

The TRIV signal generated by the head amplifier is sent to the SERVO system which acts on the phase of the drum in order to get the optimum alignment of the head within the track. (Figure 11).

In normal playback mode, an optimum alignment corresponds with a good centering of the head within the video track. Under that condition the chroma output signal has its maximum value.

The TRIV signal delivered by the head amplifier is a DC voltage which increases with the chroma output voltage amplitude.

#### Description :

The TRIV function is described with the simplified block diagram in Figure 12.

The TRIV function is simply an amplitude detector.

The transfer characteristics (TRIV output versus chroma output signal amplitude) features a higher slope at low input signal levels.

The high pass filter (cut off at 2.2MHz : TEA5703/04 ; 4.4MHz : TEA5702) rejects the amplitude modulated chroma component which would disturb the TRIV signal.

Figure 11

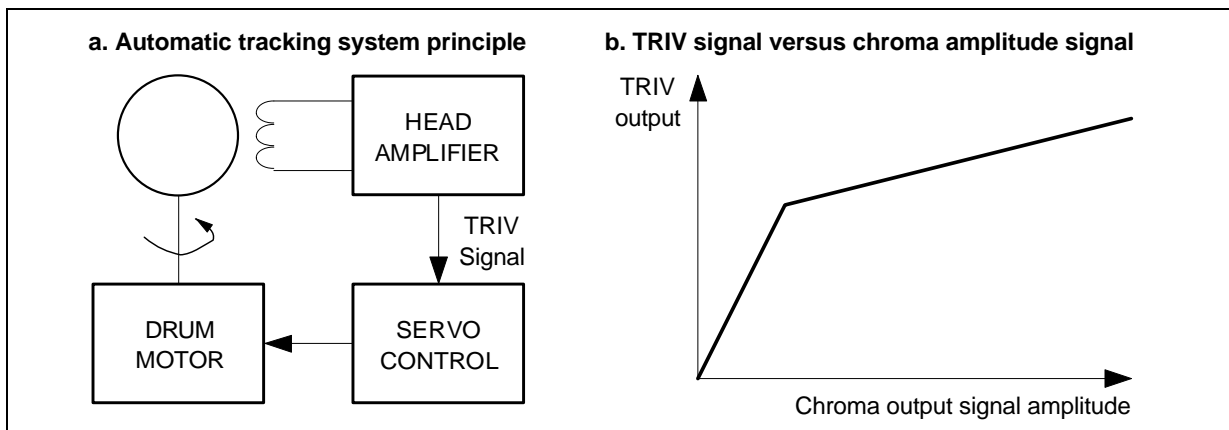

AN445-11.EPS

Figure 12 : TRIV Function Block Diagram

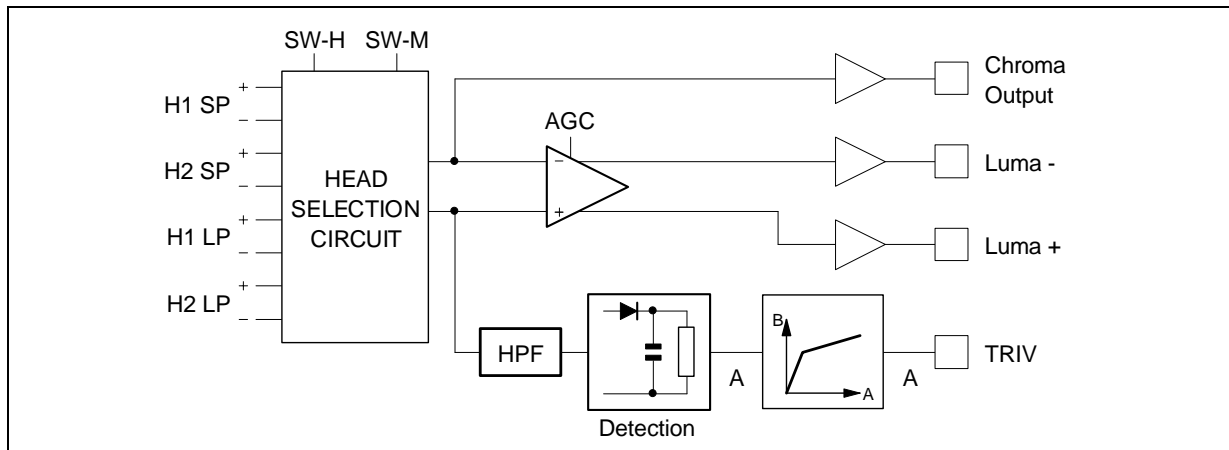

AN445-12.EPS

**III.3.f - SP/LP envelope comparator**  
(TEA5704 only) (Figure 13)

The SP/LP envelop detector output function is used in fast and slow search mode and still picture mode. In those modes this function allows to select which of the active head the pair SP head or the LP head delivers the largest signal reducing then the noise bars on the screen of the TV.

Description (Figure 14) :

The playback signal amplitudes of the SP and LP

heads that are scanning the tape are compared together. SP/LP output is high when SP signal amplitude is higher than LP signal amplitude. The signal amplitude is extracted by a detector using a multiplier, the input HPF filter rejects the amplitude modulated chroma signal, and the output low pass filter extracts the useful DC components, proportional to the input signal amplitude.

This block is able to descriminate the highest signal over a wide input signal range (from  $15\mu V_{p-pk}$  to  $600\mu V_{p-pk}$ ).

**Figure 13 :** SP/LP Function System

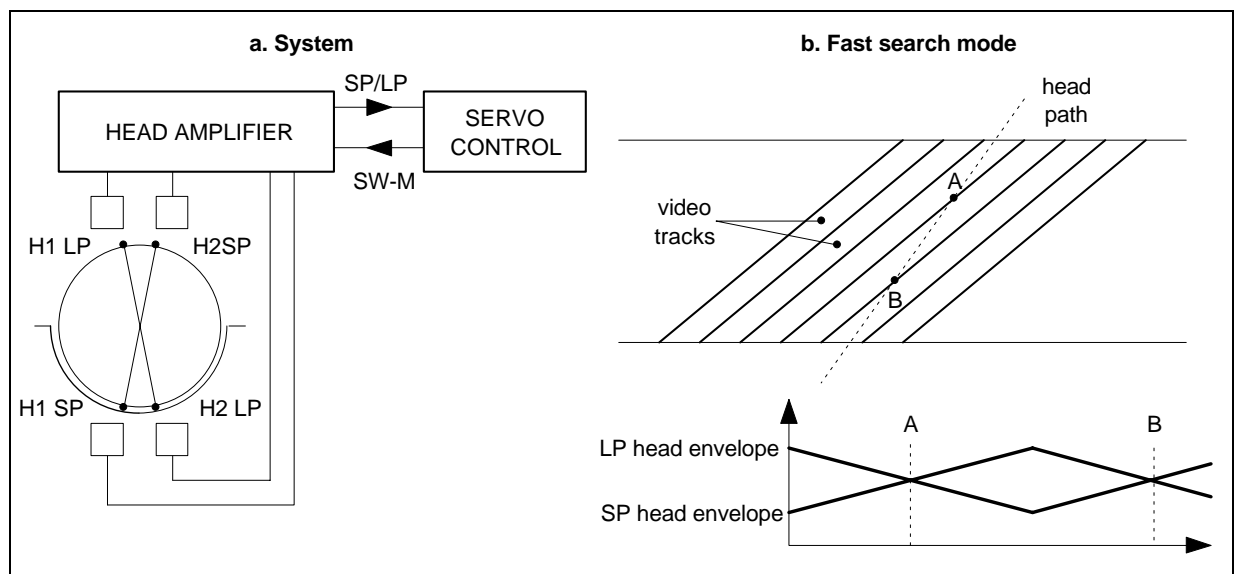

**Figure 14 :** SP/LP Detector Simplified Block Diagram

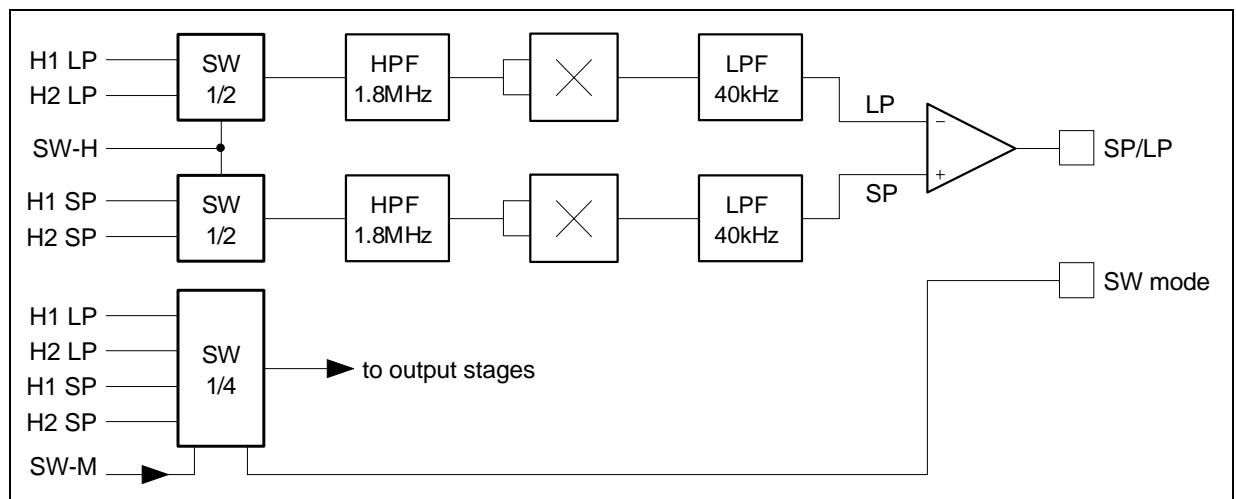

## VCR RECORD AND PLAYBACK HEAD AMPLIFIERS

### IV - FM AUDIO HEAD AMPLIFIER STV5712 : Functional Analysis

The STV5712 architecture is described in Figure 15.

**Figure 15 :** STV5712 Internal Block Diagram

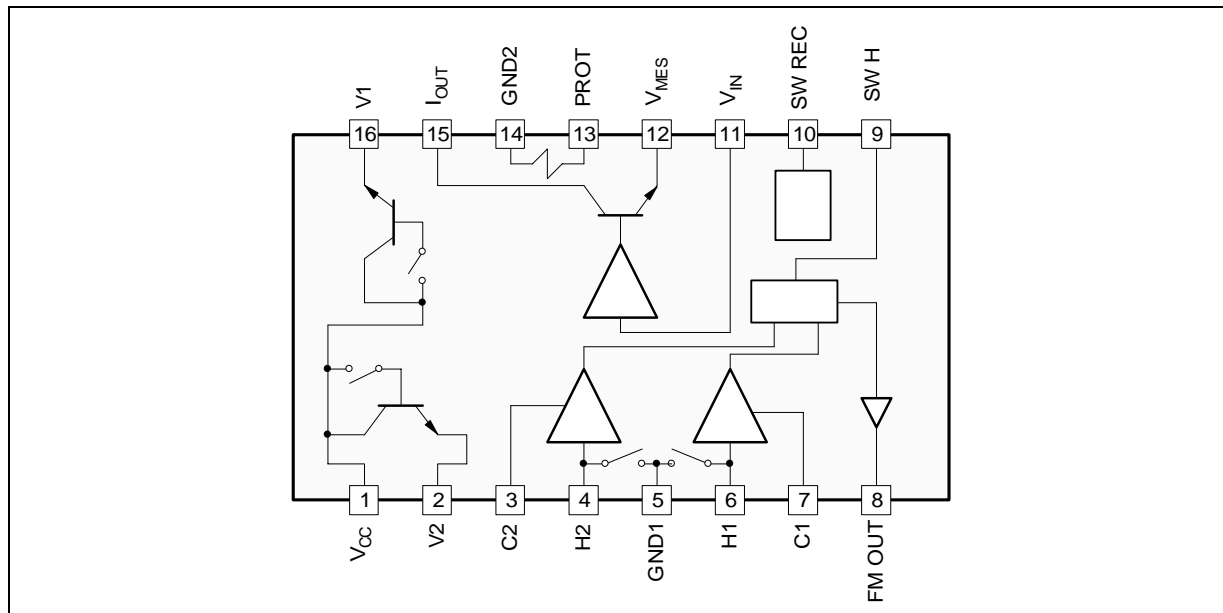

AN445-15.EPS

Although dedicated to FM audio signal most of the STV5712 internal blocks have the same structure as video head amplifiers ones. For explanations please refer to the video head amplifier description.

\* Playback section :

- low noise preamplifier with DC offset compensation
- head selection circuit
- FM output stage (similar to chroma output stage of the video head amplifiers)

\* Record section :

- record amplifier and current limitation circuit are very similar to the corresponding functions of the video head amplifiers

#### Record/Playback mode selection

About this function, the STV5712 is different from

the video head amplifiers (Figure 16).

The mode selection is made at Pin SW-REC.

$V_{SW-REC} \geq 2.4V$       Play back mode  
 $V_{SW-REC} \leq 1.5V$       Record mode

In record mode, all K switches are closed.

The recording current is supplied by  $V_{CC}$  line through Pins  $V_1$  and  $V_2$ . The playback channels are muted by grounding the inputs and disabling the output stage.

Conversely, in playback mode, the record amplifier output stage is disabled with transistor T2. To avoid high transient currents when switching from record mode to playback mode, T2 is activated when the voltage across the coupling capacitor  $C_{C1}$  and  $C_{C2}$  is less than 0.6V.

Figure 16 : Record/Playback Mode Selection

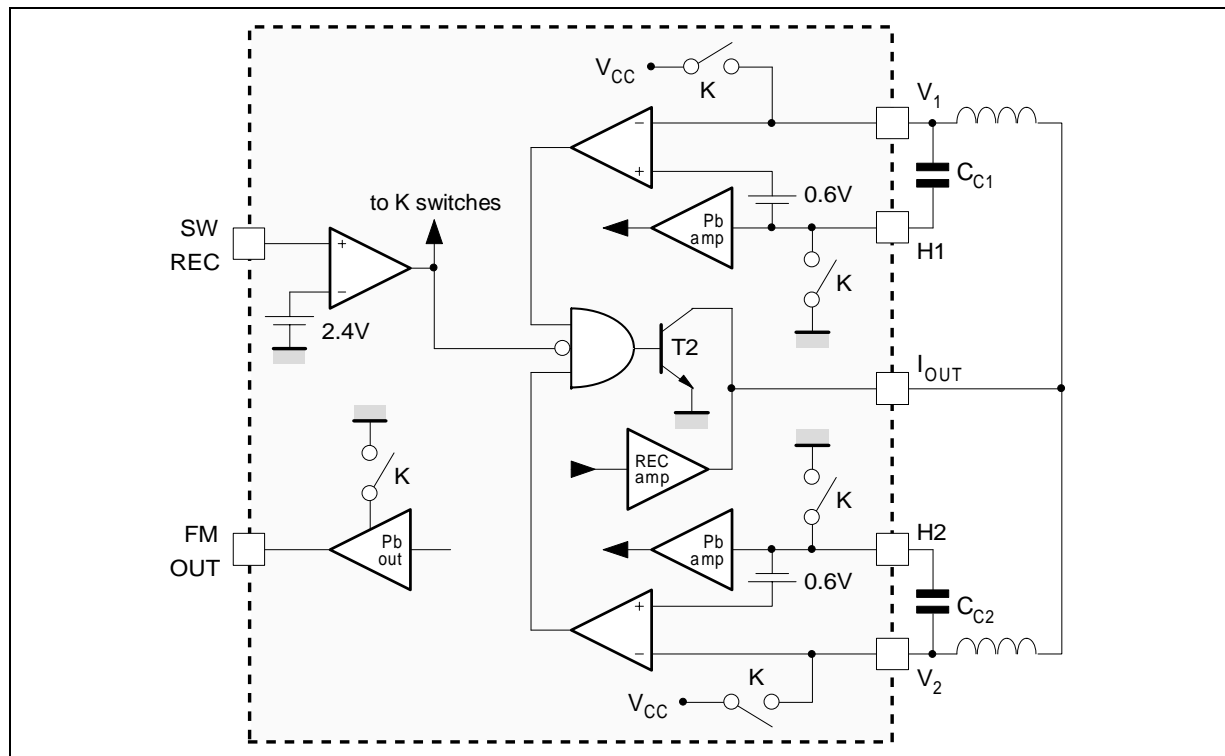

AN445-16.EPS

**V - APPLICATION NOTES**

Like the functional description, the following note is valuable for all the head amplifiers TEA5702/03/04 and STV5712. However in a specific point, additional comment will be given about the FM audio amplifier STV5712.

**V.1 - Playback Mode**

**V.1.a - Matching up video heads characteristics with the playback preamplifier**

SGS-THOMSON video heads amplifiers have been designed to work with standard video heads.

However, in order to help the user in both minimizing the noise factor of the system "head + amplifier" and controlling the frequency response, the following parameters of the input section have been characterized.

ex : TEA5704

- Input resistance  $R_{IN}$  : 600 $\Omega$  (typ.)
- Input capacitance  $C_{IN}$  : 30pF (typ.)
- Equivalent input voltage noise  $e_N$  : 0.6nV/ $\sqrt{Hz}$  (typ.)
- Equivalent input current noise  $i_N$  : 2pA/ $\sqrt{Hz}$  (typ.)

Figure 17 : Equivalent Model of the Input Circuit

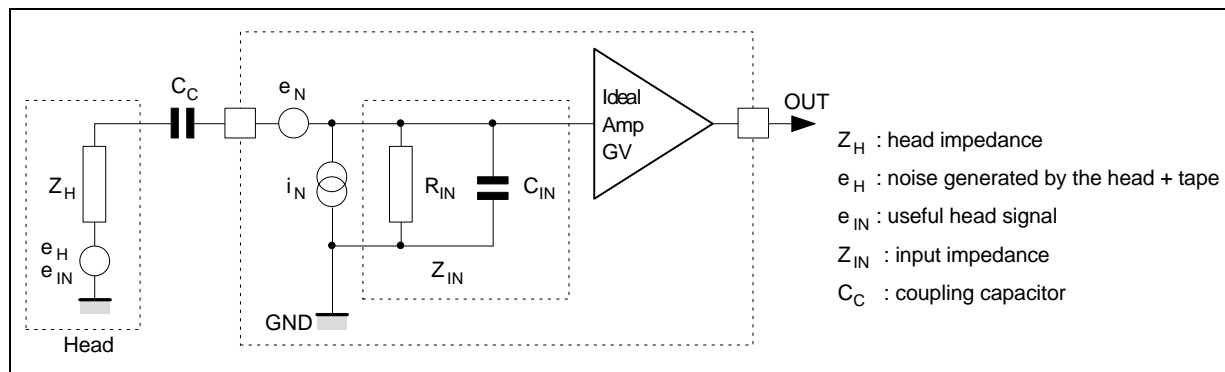

AN445-17.EPS

## VCR RECORD AND PLAYBACK HEAD AMPLIFIERS

### Minimizing the noise factor of the system "head + amplifier"

The noise factor is defined as following :

$$(1) \quad NF = \frac{(S/N)_{IN}}{(S/N)_{OUT}} = \frac{\left(\frac{e_{IN}}{e_H}\right)^2}{\frac{G_V^2 \cdot V_{IN}^2}{G_V^2 \cdot E_N^2}} = \frac{E_N^2}{V_{IN}^2} \cdot \frac{e_{IN}^2}{e_H^2}$$

$V_{IN}$  : useful signal at the preamplifier input pin

$E_N$  : Total equivalent noise at the preamplifier

$$(2) \quad V_{IN} = \frac{Z_{IN}}{Z_{IN} + Z_H} e_{IN} \quad \left(\frac{1}{C_{\omega}} \ll |Z_{IN}| \right)$$

$$(3) \quad E_N^2 =$$

$$(3) \quad E_N^2 = e_H^2 \left| \frac{Z_{IN}}{Z_{IN} + Z_H} \right|^2 + e_N^2 \left| \frac{Z_{IN}}{Z_{IN} + Z_H} \right|^2 + i_N^2 \left| \frac{Z_{IN} \cdot Z_H}{Z_{IN} + Z_H} \right|^2$$

$$(1), (2), (3) \Rightarrow NF = 1 + \frac{e_N^2}{e_H^2} + \frac{|Z_H|^2 \cdot i_N^2}{e_H^2} \quad (4)$$

Characterizing separately the noise voltage  $e_N$  and noise current  $i_N$  gives to the user a better understanding of noise factor characteristics of the complete set (preamplifier + head) versus parameters such as head impedance, frequency, head + tape noise.

**Figure 18** : Controlling the peaking effect

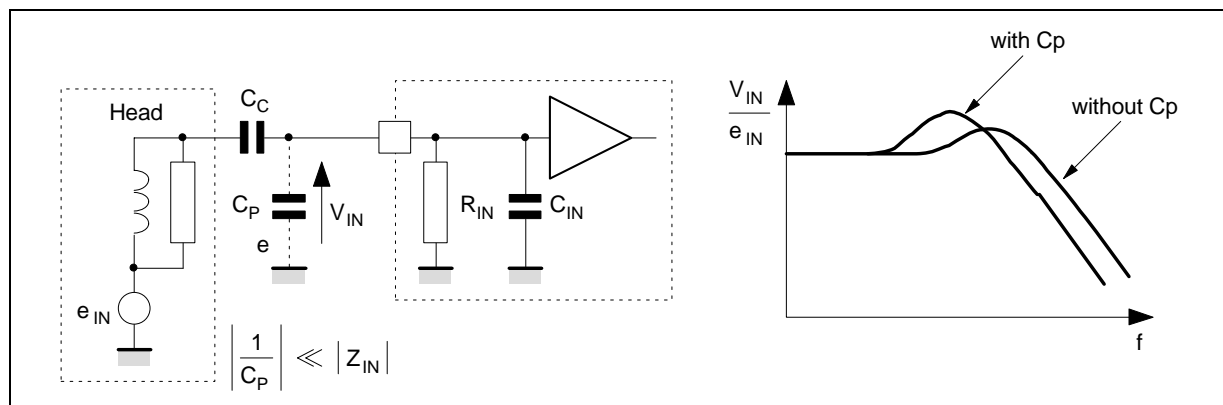

### Controlling the frequency response (peaking effect)

The inductive characteristics of the impedance of the heads associated to the capacitive characteristics of the input impedance of the preamplifier section naturally give a peaking effect in the frequency response (Figure 18).

The low input capacitance value featured by the TEA57XX head amplifier family will lead to small peaking effects.

When necessary the peaking effect can be increased by adding a compensation capacitor in parallel with the input impedance.

In Annexe 1 (page 22) a detailed explanation of the peaking effect is given.

### V.1.b - Interfacing with the VCR main board

In this part, are described the recommended circuitry to be implemented between the head amplifier and the VCR main board. The following functions are involved.

- luma outputs
- chroma output
- TRIV function
- SP/LP detector (TEA5704 only)

In a typical application, the external circuits are the following (see Figure 19).

Figure 19 : Interfacing with the VCR Main Board

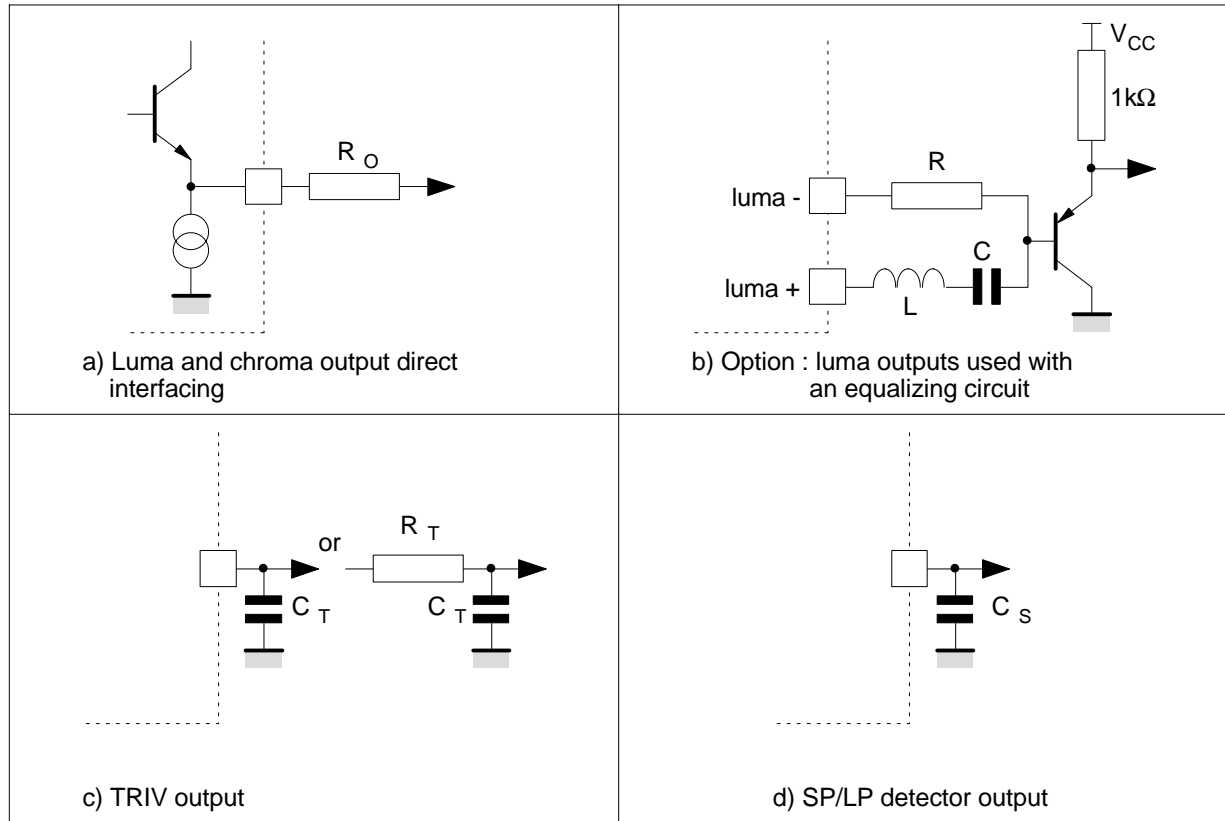

AN445-19.EPS

- Luma and chroma outputs : In most of the applications the luma and chroma outputs are directly connected to the luma and chroma processors located on the main board. The emitter follower structure of the output stages allows this direct connection without external buffer. However, a serial resistor  $R_O$  is recommended to prevent the output stage from oscillations when the load becomes highly capacitive  $C_L > 50\text{pF}$ . Good stability have been experienced for  $R_O \geq 47\Omega$ . In some particular applications both luma + and luma - outputs are used when an equalizing circuit is used on the head amplifier board (see Figure 19b.)
- TRIV output : Typically a simple filtering capacitor  $C_T$  is enough at this output. For a better filtering  $R_T C_T$  filter can be also used.  $C_T$  value is not critical,  $C_T$  (typ.) : 22nF
- SP/LP detector output (TEA5704 only) : Typically a simple filtering capacitor  $C_s$  is used at this output.  $C_s$  (typ.) : 1nF

**V.2 - Record Mode**

**V.2.a - Current peaking / RC damping network**

As mentioned in chapter (III.2.a.) the record channel has a transconductance which can be calculated as following :

$$\frac{I_{REC}}{V_I} \cong \frac{R_F + R_M}{R_{IN} \times R_M}$$

The frequency response of this transconductance remains flat with a (-3dB) cut-off frequency higher than 10MHz.

However when the record amplifier is loaded with video heads, very often a current peaking affect may be noticed in the heads.

This peaking effect is generated by a LC resonating network in which L is the inductance of the head in parallel and C the sum of the parasitic capacitance  $C_H$  of the heads with the parasitic capacitance  $C_O$  of the output transistor of the record amplifier (collector to ground capacitance  $\cong 15\text{pF}$ ) (see Figure 20).

## VCR RECORD AND PLAYBACK HEAD AMPLIFIERS

**Figure 20** : Current Peaking Effect / Damping Network

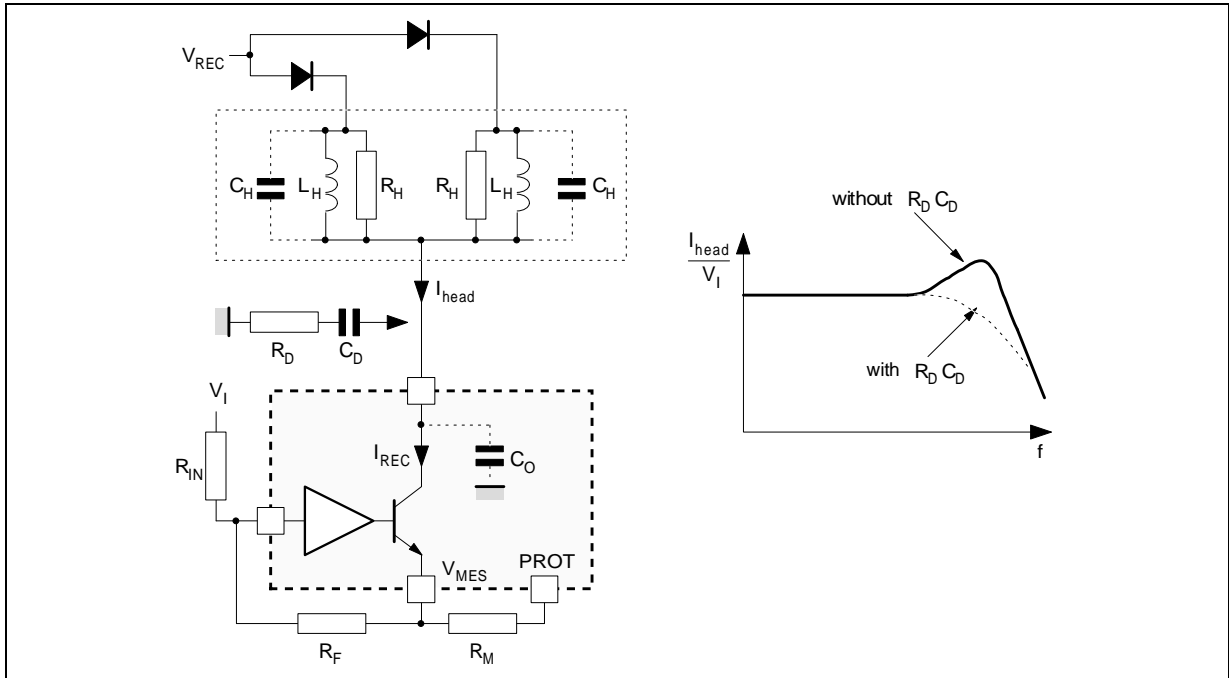

Assuming the head impedance can be modeled by a parallel  $L_M R_R$  network, the transfer function of the transconductance is :

$$\frac{I_{\text{head}}}{V_I} \cong \frac{I_{\text{head}}}{I_{\text{REC}}} \times \frac{I_{\text{REC}}}{V_I} \cong \frac{R_F + R_M}{R_{IN} \cdot R_M} \left( \frac{R + L_P}{LC R_P^2 + L_P + R} \right)$$

( $I_{\text{head}}$  : total current in head pair /  $L = \frac{L_H}{2}$  /  $R = \frac{R_H}{2}$ )

In order to avoid the current peaking a  $R_D C_D$  damping network can be connected at the output. The value  $R_D$  of the resistor must be chosen to satisfy the following compromise : keeping a high bandwidth and a good damping of the peaking effect. A approximative value of  $R_D$  is :  $\sqrt{\frac{2L}{C}}$

### V.2.b - Mixing Y and C input signals

The input of the record amplifiers can be considered as a virtual ground. Consequently the input signal  $V_{IN}$  can be either a composite signal in which Y and C have been already mixed, or separated and Y and C signals. In this last case the two signals will be added one to the other by the record amplifier.

### V.2.c - Current limitation

When the current limitation circuit is not used or not requested by the user. Simply shunt this function by connecting Pin PROT to Pin GND.

### V.3 - Printed Copper Board Layout

Stability, bandwidth, crosstalk are parameters which are greatly influenced by the PCB layout. Here below are given basic advices to implement a PCB layout which affects in the lowest extent as possible those parameters. To illustrate this chapter an example of recommended layout is given in Figure 21.

#### Preliminary remark : Important

All SGS-THOMSON head amplifiers feature two types of ground pins : small signal ground and large signal ground. The two types of ground are not internally connected, they are isolated one from the other.

	Small Signal GND	Large Signal GND
TEA5702	GND1 / GND2	GND3
TEA5703	GND1 / GND2	GND3
TEA5704	GND1 / GND2	GND3
STV5712	GND1	GND2

The following functions are connected to the small signal GND :

- Preampfier
- DC offset compensation circuit
- The switching transistor which shunts the record current output ( $I_{OUT}$ ) in playback mode.

Any other internal function is referenced to the large signal GND.

Figure 21 : Example of Recommended PCB Layout for Playback Mode (TEA5704)

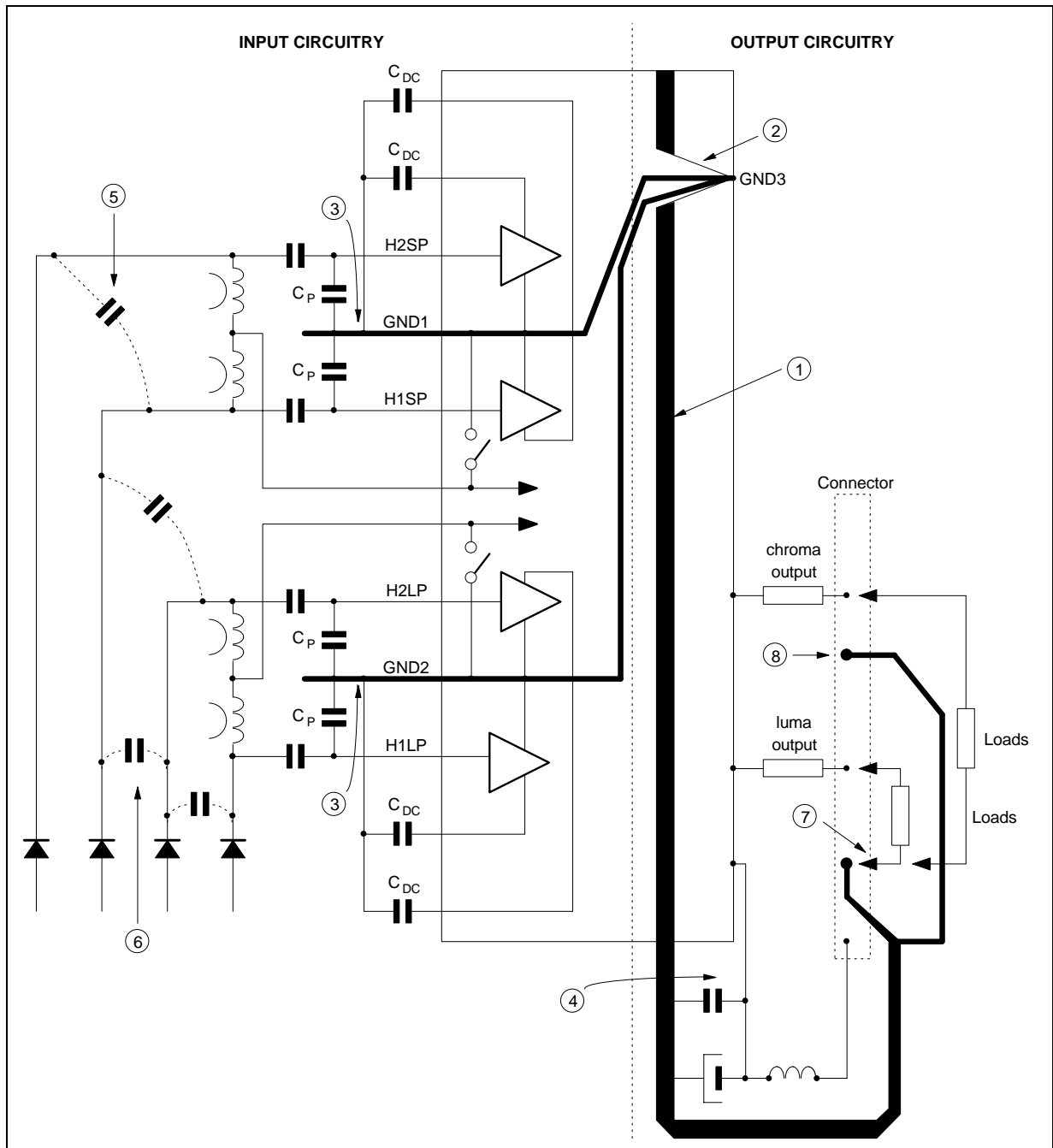

AN445-21.EPS

**V.3.a - Stability in playback mode**

A good stability in playback mode is obtained by minimizing the coupling between the output signals and the input circuitry. To do so, it can be recommended :

- to put a ground path between the input circuitry and output circuitry . It minimizes the coupling capacitor ①
- to make a star connection of GND1/GND2/GND3

at GND3 Pin. In this way the resistive coupling between the output circuits and the input circuit is minimum. The large output currents cannot produce voltage drop ( $\Delta V$ ) which may disturbs the input sections. ②

- to connect to the small signal grounds : ③
- the DC offset compensation capacitor  $C_{DC}$
- the optional peaking capacitor  $C_P$

## VCR RECORD AND PLAYBACK HEAD AMPLIFIERS

### V.3.b - Gain and bandwidth in playback mode

The high gain and wide bandwidth characteristics of the preamplifier may be decreased by a poor  $V_{CC}$  filtering. A particular care must be taken in lowering  $V_{CC}$  Line impedance.

The filtering capacitor must be as close as possible to the  $V_{CC}$  Pin. Very often a ceramic capacitor added to the electrolytic improves the filtering. ④

### V.3.c - Minimizing crosstalk in playback mode

The crosstalk is mainly generated by capacitive effect between tracks in the input circuitry of the application. Although the pinning of the inputs sections of the head amplifiers have been studied to minimize this effect, it is important in the layout to keep enough distance between input tracks or in some cases to insert a ground path between two tracks. ⑤

For illustration a parasitic C of 1pF induces a 48dB crosstalk at 3.8MHz.

$$(C_{tlk})_{dB} = 20 \text{ Log } \frac{Z_{IN} // Z_{Head}}{Z_{IN} // Z_{Head} + \frac{1}{C_P}}$$

### V.3.d - Minimizing crosstalk :

Particular case of TEA5704

In a four head application, two heads are simultaneously scanning the tape H1SP and H2LP or H1LP and H2SP. Then in the PCB layout a particular care must be taken in minimizing the capacitive crosstalk between those channels. ⑥

### V.3.e - Connecting the VCR main board

In interfacing with the main board, some care may be taken to avoid some oscillations problems.

For instance it is recommended to make sure that the loads of the luma and chroma outputs will be connected to a power ground directly connected to the  $V_{CC}$  supply ground. ⑦

To avoid coupling effect, it can be recommended to have a GND wire between luma and chroma wires in the ribbon cable which connects the head amplifiers board to the VCR main board. ⑧

### V.3.f - Stability in record mode

In record mode, some care has to be taken in the PCB layout to prevent the application from oscillations.

Like for any other amplification it is important to minimize the parasitic coupling between the input and output parts.

Practically, the high current path should not disturb ground path which links the large signal ground of the integrated circuit to the ground pin of the input signal.

The high current paths are :

- the loop made by the capacitor  $C_1$ , the diode D, the heads, the resistor R connected between Pin  $V_{MES}$  and Pin PROT, and the ground path linking GND3 to capacitor  $C_1$
- the RC damping network connected between  $I_{OUT}$  and the ground.

### V.4 - STV5712 additional advices

All the recommendations given for the video head amplifiers are valuable for the FM audio head amplifiers.

Additionally, please note that the voltage must be lower than 0.6V at  $V_1$  and  $V_2$  outputs to allow playback mode.

**Figure 22 :** Record Mode. Example of Recommended Layout of the Record Current Paths (TEA5704)

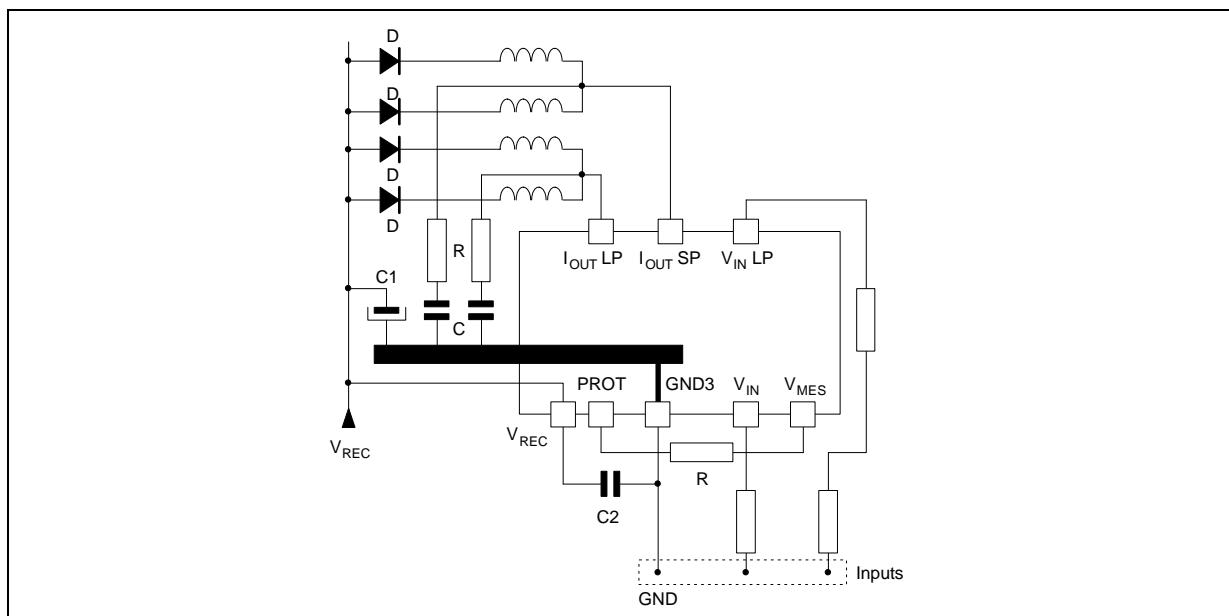

V.5 - Typical Application Circuits

Figure 23 : TEA5704 / STV5712 Typical Application Diagram

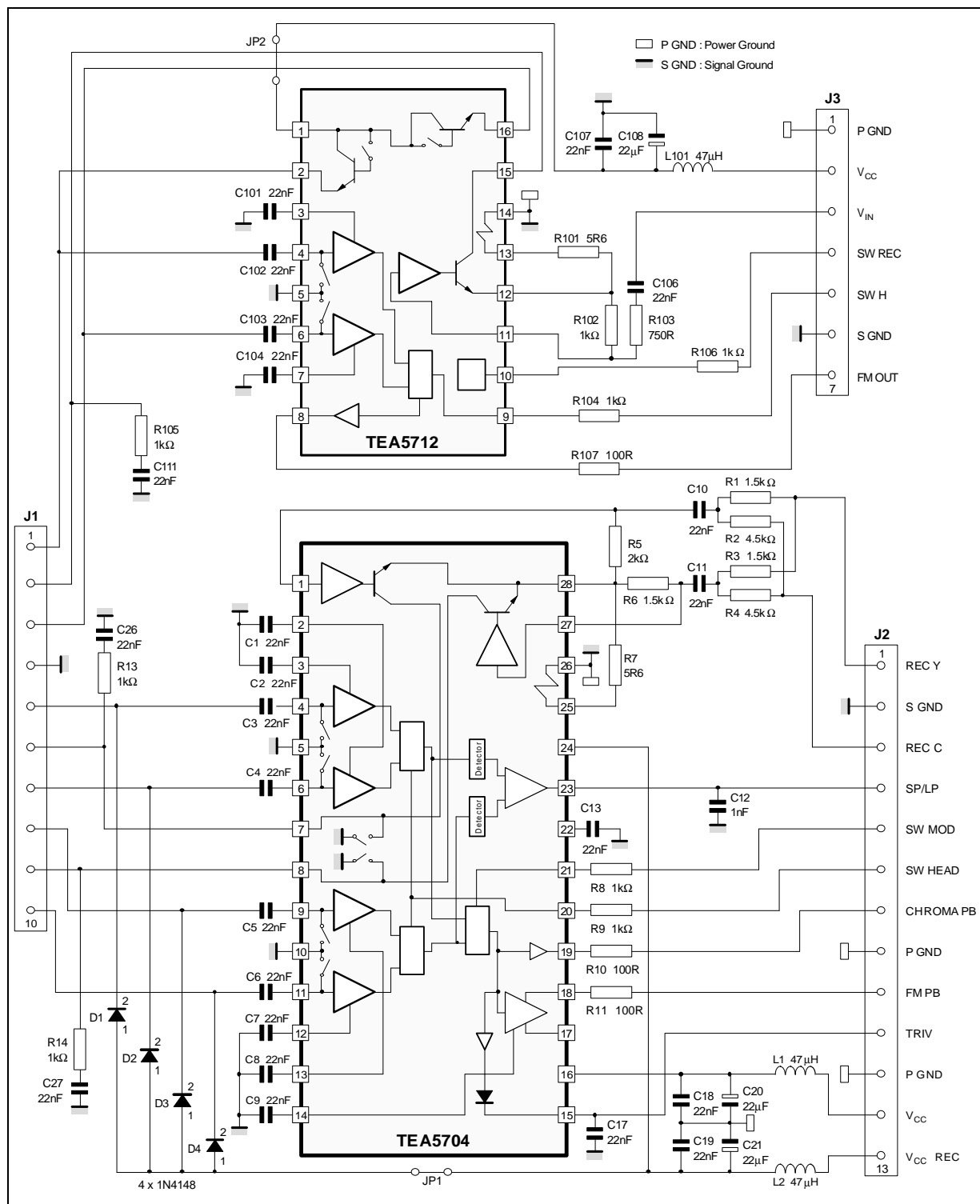

# VCR RECORD AND PLAYBACK HEAD AMPLIFIERS

Figure 24 : TEA5703 Typical Application Diagram

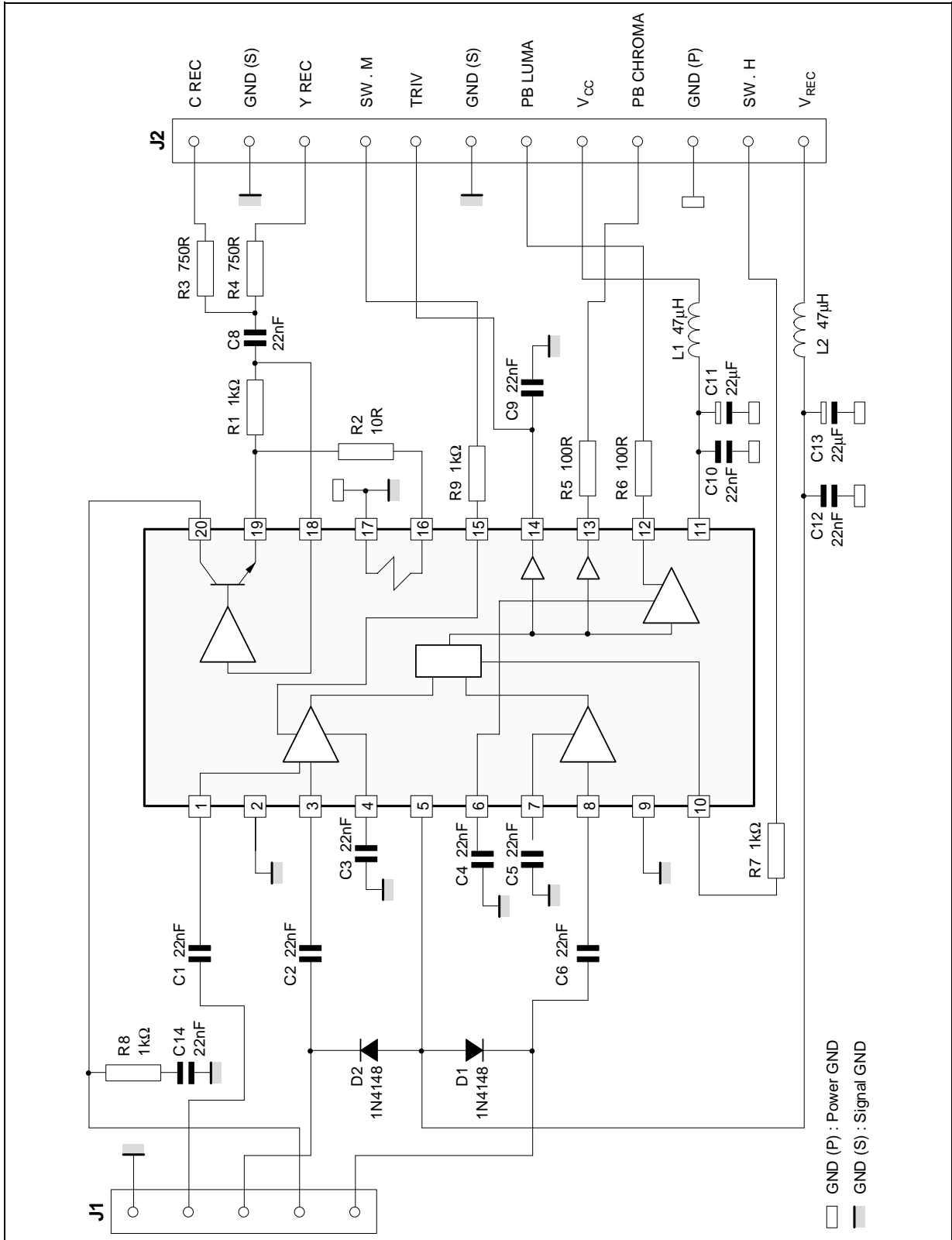

AN445-24.EPS

# VCR RECORD AND PLAY BACK HEAD AMPLIFIERS

Figure 25 : TEA5702 Typical Application Diagram

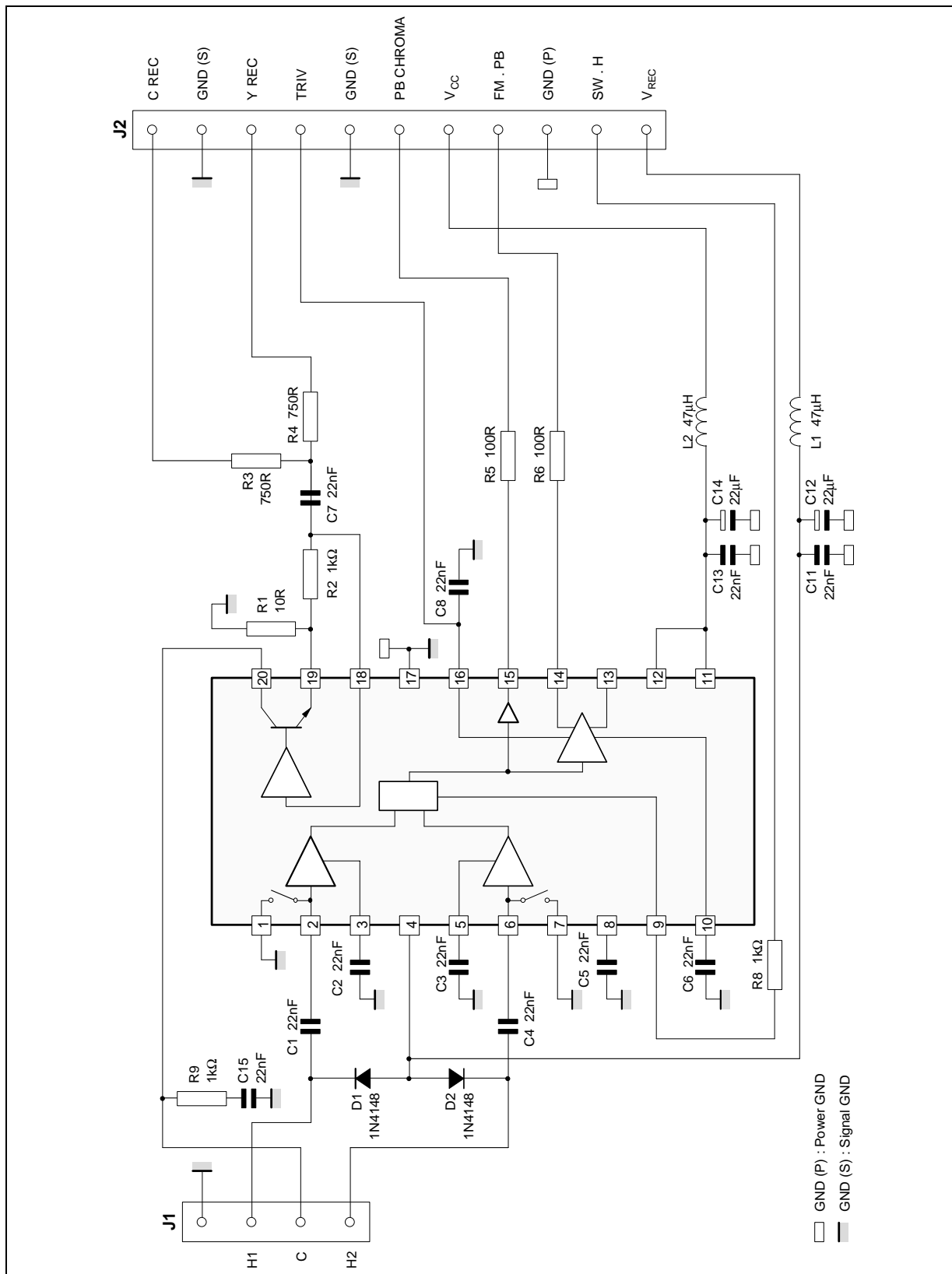

AN445-25.EPS

## VCR RECORD AND PLAYBACK HEAD AMPLIFIERS

### V.6 - Application with Single 5V Supply Line

When the VCR system provides only one  $V_{CC}$  line to the head amplifier board ; this supply line is used for both playback and record mode. For this type of application the circuit given in Figure 26 can be used.

Q1 used as a switch which is closed in record mode, then  $V_{REC}$  value is :

$$V_{REC} = V_{CC} - V_{SAT}(Q1)$$

#### Important Remark :

The open collector structure of the output stage of the record amplifier allows the voltage at pin I<sub>OUT</sub> to be higher than the record supply voltage  $V_{REC}$ . At maximum the voltage at pin I<sub>OUT</sub> can be twice higher than  $V_{REC}$  (see Figure 27).

Consequently the voltage swing across the load can remain the same with a twice lower  $V_{REC}$ . In other words a conventional solution using a double supply line (i.e.  $V_{CC} : 5V$ ,  $V_{REC} : 9V$ ) can be easily replaced by a single 5V line.

Figure 26 : Application Circuit with Common  $V_{CC}$

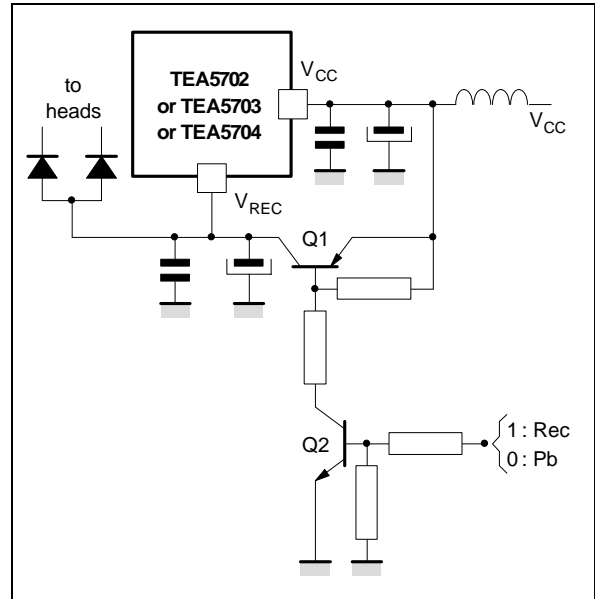

AN445-26 EPS

Figure 27 : Output Voltage Swing versus Record Amp Structure

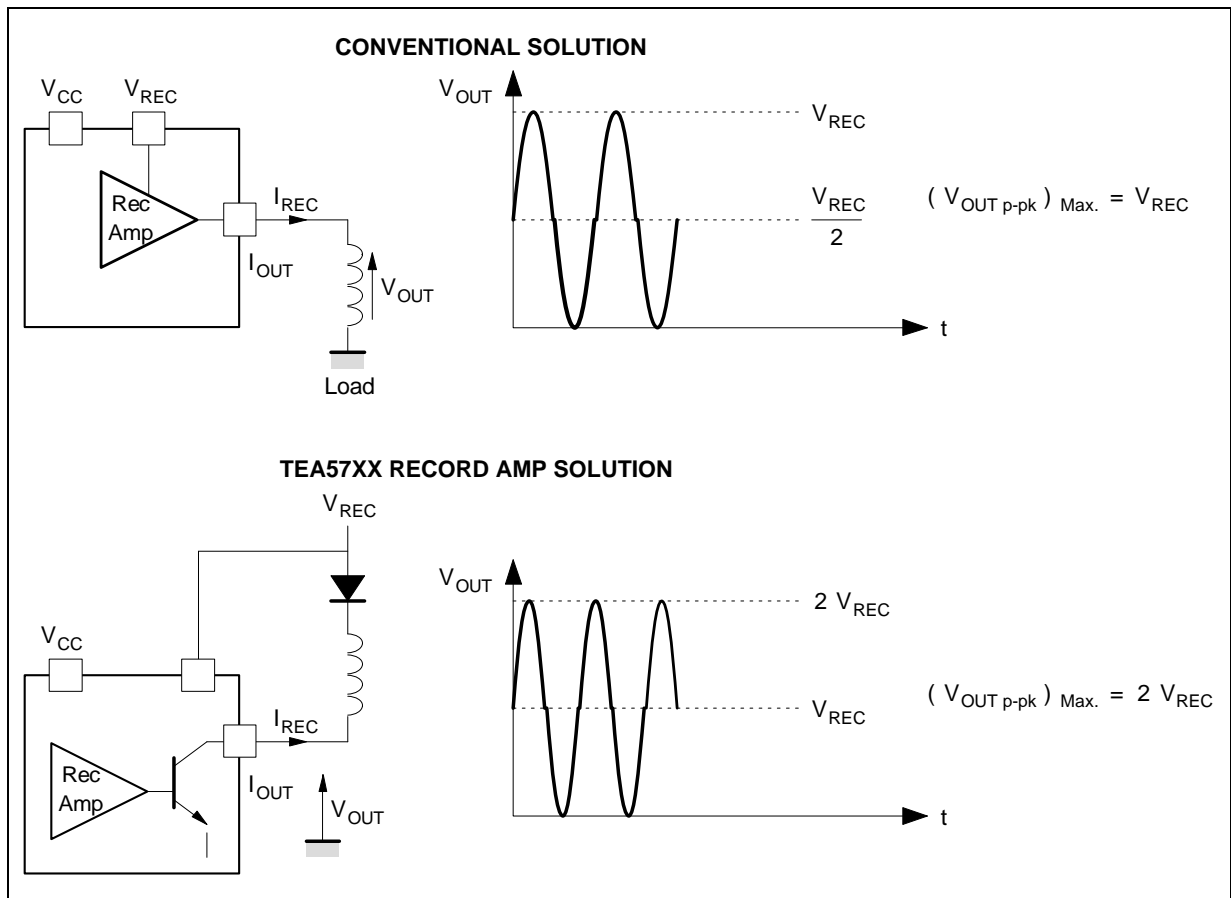

AN445-27 EPS

**VI - ANNEXE : Playback Bandwidth Peaking Effect**

To better understand the origin of the peaking effect, please refer to Figure 28 which gives a model of the set : head + preamplifier.

It is assumed in this part that the impedance of the heads seen through the rotary transformer is modeled by a parallel  $L_H, R_H$  network.

**Figure 28 :** Equivalent Model of the Preamp Stage Driven by a Video Head

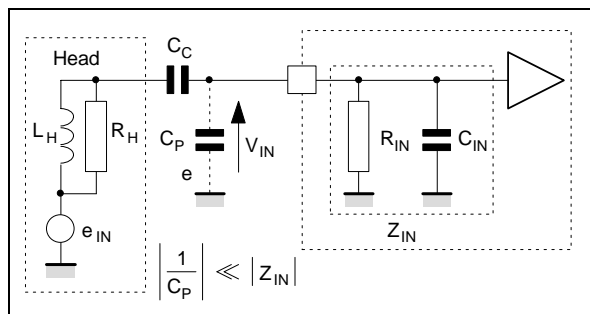

- $e_{IN}$  : signal generated by the head
- $V_{IN}$  : signal which actually drives the preamplifier
- $R_{IN}$  : preamplifier input resistance
- $C_{IN}$  : preamplifier input capacitance (remark : the above model and herebelow calculations are not affected when  $C_{IN}$  also takes into account the parasitic capacitor of the head impedance)

**a) Calculations**

Let's evaluate, the transfert function  $\left(\frac{V_{IN}}{e_{IN}}\right)(p)$

$$(1) \quad V_{IN} = e_{IN} \cdot \frac{Z_{IN}}{Z_{IN} + Z_{Head}}$$

$$(2) \quad \left(\frac{V_{IN}}{e_{IN}}\right)(p) = \frac{\left(1 + \frac{L_H}{R_H} p\right)}{1 + \left(\frac{L_H}{R_H} + \frac{L_H}{R_{IN}}\right) p + L_H C_{IN} p^2} = \frac{N(p)}{D(p)}$$

Generally, the cut-off frequency of  $N(p)$  is in the range of 40MHz to 50MHz ( $L_H \text{ Typ.} \cong 8\mu\text{H}$ ,  $R_H \text{ Typ.} \cong 2\text{k}\Omega$ )

So in the useful frequency range (100kHz  $\rightarrow$  10MHz)  $\left(\frac{V_{IN}}{e_{IN}}\right)(p)$  can be simplified as following.

$$(3) \quad \left(\frac{V_{IN}}{e_{IN}}\right)(p) \cong \frac{1}{D(p)} \quad (100\text{kHz} < f < 10\text{MHz})$$

Referring to a general study of transfert functions  $D(p)$  can be modeled as following :

$$(4) \quad D(p) = 1 + 2 \varepsilon \frac{p}{\omega_0} + \frac{p^2}{\omega_0^2}$$

where  $2\varepsilon = \frac{1}{Q}$  : Damping factor

$\omega_0 = 2\pi f_0$  : Resonating frequency

$$(2) \text{ and } (4) \Rightarrow \begin{cases} 2\varepsilon = \frac{1}{Q} = \sqrt{\frac{L_H}{C_{IN}}} \left(\frac{1}{R_H} + \frac{1}{R_{IN}}\right) \\ \omega_0 = \frac{1}{\sqrt{L_H C_{IN}}} \quad \omega_0 = 2\pi f_0 \end{cases}$$

The function  $\frac{1}{D(p)}$  has the following characteristics versus  $\varepsilon$  value :

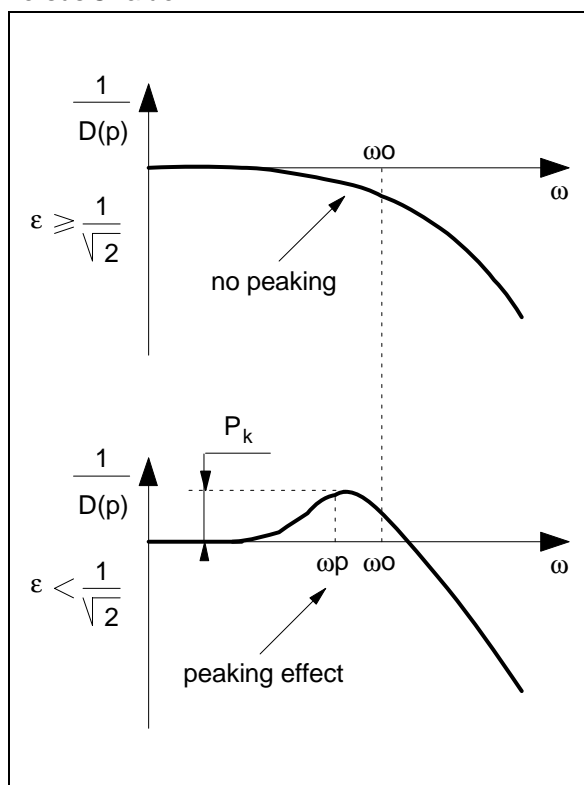

When  $\varepsilon < \frac{1}{\sqrt{2}}$  a peaking effects appears :

$$\Rightarrow \text{peaking frequency } f_p = \frac{\omega_p}{2\pi} = f_0 \sqrt{1 - 2\varepsilon^2}$$

$$\Rightarrow \text{peaking amplitude } P_k = \left(\frac{V_{IN}}{e_{IN}}\right)_{f_p} = \frac{1}{2\varepsilon \sqrt{1 - \varepsilon^2}}$$

## VCR RECORD AND PLAYBACK HEAD AMPLIFIERS

### b) Controlling the peaking effect

In the application, the user may need to amplify the original peaking induced by the preamplifier input impedance.

To increase the peaking amplitude it is necessary to decrease the damping factor value  $\varepsilon$ .

$$2\varepsilon = \sqrt{\frac{L_H}{C_{IN}}} \left( \frac{1}{R_H} + \frac{1}{R_{IN}} \right)$$

The simplest way is to increase  $C_{IN}$  value by adding an external capacitor  $C_P$  in parallel with the input impedance.

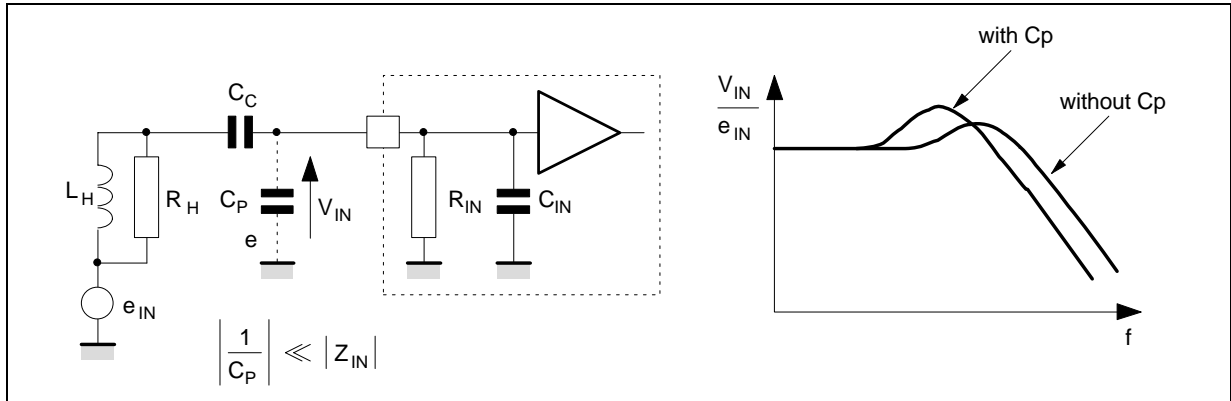

Information furnished is believed to be accurate and reliable. However, SGS-THOMSON Microelectronics assumes no responsibility for the consequences of use of such information nor for any infringement of patents or other rights of third parties which may result from its use. No licence is granted by implication or otherwise under any patent or patent rights of SGS-THOMSON Microelectronics. Specifications mentioned in this publication are subject to change without notice. This publication supersedes and replaces all information previously supplied. SGS-THOMSON Microelectronics products are not authorized for use as critical components in life support devices or systems without express written approval of SGS-THOMSON Microelectronics.

© 1994 SGS-THOMSON Microelectronics - All Rights Reserved

Purchase of I<sup>2</sup>C Components of SGS-THOMSON Microelectronics, conveys a license under the Philips I<sup>2</sup>C Patent. Rights to use these components in a I<sup>2</sup>C system, is granted provided that the system conforms to the I<sup>2</sup>C Standard Specifications as defined by Philips.

SGS-THOMSON Microelectronics GROUP OF COMPANIES

Australia - Brazil - China - France - Germany - Hong Kong - Italy - Japan - Korea - Malaysia - Malta - Morocco  
The Netherlands - Singapore - Spain - Sweden - Switzerland - Taiwan - Thailand - United Kingdom - U.S.A.



LittleDiode supplies new, hard to find or obsolete electronic components and semiconductors all over the world.

With over two million different components listed you are sure to find the part you need.

Feel free to visit us today at our online store:

[LittleDiode.com](http://LittleDiode.com)

Looking forward to providing you with the best possible service.