

SERIES OPERATION OF FAST RECTIFIERS

B. Rivet

The use of several rectifiers connected in series is necessary to obtain voltage ratings beyond the capabilities of single diodes and also when some special requirement, such as very low switching losses, requires the implementation of several low voltage ultra fast diodes.

Rectifiers connected in series tend to unequally share the voltage across the string in blocking conditions because of the variations in reverse characteristics : leakage currents and turn-off switching parameters.

To ensure that each diode operates within its voltage rating, it is generally necessary to add a voltage sharing network.

This paper gives the rules of calculation of this auxiliary network and shows how this circuit could be optimized : reduction of power dissipation and cost.

I - STEADY STATE VOLTAGE SHARING :

The difference in blocking characteristics results in unequal steady state voltage (fig.1).

Figure 1 : Dispersion of diodes reverse characteristics. The reverse current through the string D1, D2,Dn is I_R and the voltages across the diodes are respectively V_1, V_2, \dots, V_n .

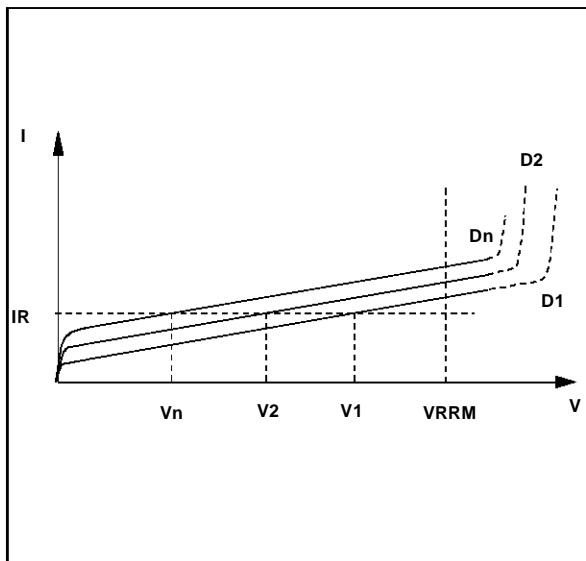

AN443/0691

In order to equalize the voltage, a resistor is connected across each diode (Fig.2).

Figure 2 : Use of shunt resistors for steady state voltage sharing.

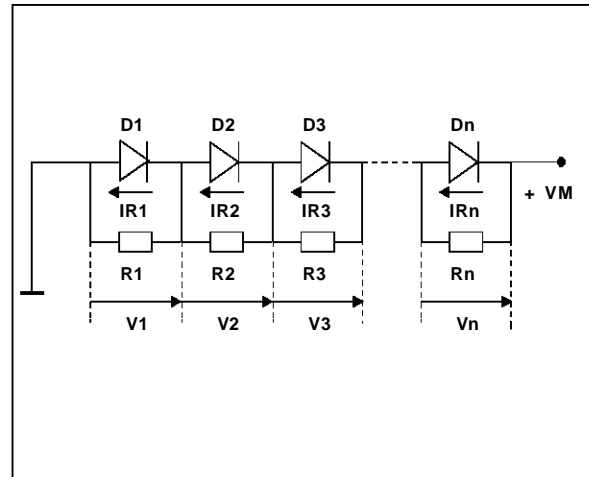

1) Calculation of sharing resistors :

The calculation of these resistances is based on the worst case situation.

The maximum imbalance in blocking voltage when n diodes are connected in series occurs when $(n-1)$ diodes have the maximum leakage current and one diode D_1 has the lowest possible leakage current.

In this case D_1 will support the highest voltage V_1 , and this tendency is aggravated by the assumption that the corresponding resistor R_1 is at the upper limit of its tolerance (a), while all the others are at the lowest limit so,

$$R_1 = R(1+a)$$

$$R_2 = R_3 = \dots R_n = R$$

In order to calculate the current in the string we approximate the reverse characteristic with a straight line. We define the slope by the coefficient k according to fig.3.

1/8

Figure 3 : Reverse characteristic model of a fast rectifier.

$$I_R + I_{RM}(T_j) \cdot \left[k + \frac{V_R(1-k)}{V_{RRM}} \right]$$

With $k = 0.8$

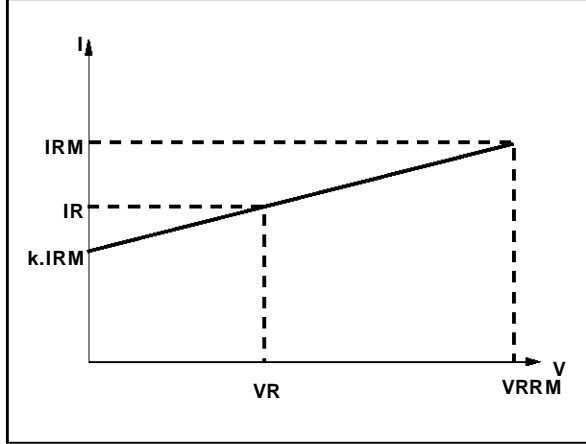

The leakage current I_{RM} of diodes D2 ... Dn under the blocking voltage $V_2 ... V_n$ is :

$$I_{R2} = I_{R3} = \dots I_{Rn} = I_{RM} \left[k + \frac{V_n(1-k)}{V_{RRM}} \right]$$

where I_{RM} is the maximum leakage current at V_{RRM} (maximum voltage specified for this diode) and at the operating junction temperature. For D1 the maximum reverse current at V_{RRM} is :

$$I_{RM} - \Delta I_R$$

In these conditions the leakage current of diode D1 is :

$$I_{R1} = (I_{RM} - \Delta I_R) \left(k + \frac{V_1(1-k)}{V_{RRM}} \right)$$

Taking into account all these parameters, the voltage V_1 across the diode D1 is given by the relation :

$$V_1 = \frac{V_M(1+a)(V_{RRM} + (1-k)I_{RM}R) + k(n-1)(1+a)\Delta I_R R V_{RRM}}{R I_{RM} n(1-k)(1+a) + V_{RRM}(n+a) - R \Delta I_R (1-k)(1+a)(n-1)} \quad (1)$$

The resistance R must be chosen to limit the voltage V_1 under the maximum value V_{RRM} specified for this rectifier. Thus :

$$R < \frac{V_{RRM}(V_{RRM}(n+a) - V_M(1+a))}{\Delta I_R V_{RRM}(1+a)(n-1) - I_{RM}(1-k)(1+a)(nV_{RRM} - V_M)} \quad (2)$$

For today's fast rectifiers we can use $k=0.8$.

2) I_{RM} evaluation

I_{RM} is the maximum leakage current at the maximum reverse voltage V_{RRM} . This current depends on the junction temperature (Fig.4).

Generally, the manufacturer specifies a maximum value I_{RM} at V_{RRM} at $T_j=100^\circ\text{C}$, in the data sheet.

When we know the operating junction temperature (T_j), it is possible to calculate I_{RM} by using the following relation :

$$I_{RM}(T_j) = I_{RM}(100^\circ\text{C}) \exp[-0.054(100-T_j)]$$

Figure 4 : Reverse leakage current versus junction temperature.

Example :
BYT 261-1000 (typical value)

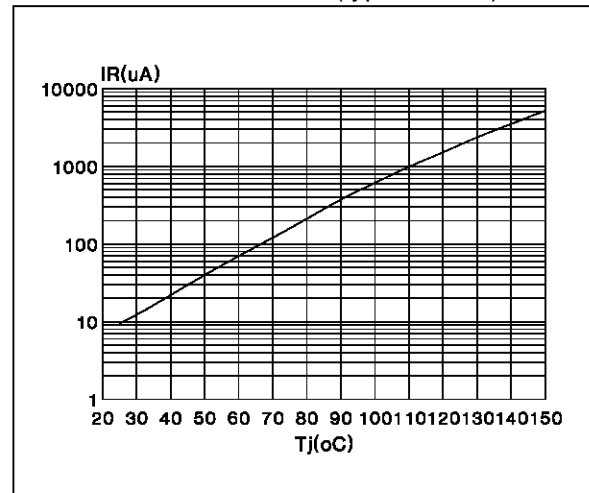

3) ΔI_R estimation

In fact ΔI_R is the sum of ΔI_{R1} and ΔI_{R2}

- ΔI_{R1} is due to the leakage current dispersion of the rectifiers in the same conditions of voltage and temperature.

For the fast rectifiers available today on the market the dispersion of the reverse current at $V_R = V_{RRM}$ and $T_j = 100^\circ\text{C}$ is about :

$$\Delta I_{R1} = 0.6 I_{RM}$$

This dispersion varies from one batch to another.

- ΔI_{R2} is due to the difference between the junction temperatures of each device (ΔT_j).

Figure 5 : The variation ΔI_R is the dispersion of I_R at max operation junction temperature (ΔI_{R1}) plus the variation due to T_j (ΔI_{R2})

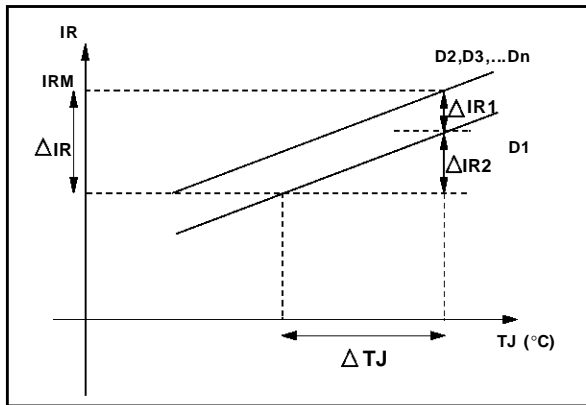

The junction temperature is given by the thermal resistance junction to ambient $R_{th}(j-a)$ and the power dissipation due to the conduction losses (PC) and the switching losses (PS).

PC is linked to the forward voltage (V_F) and PS is linked to the reverse recovery charge (Q_{RR}). So the variation of the junction temperature is :

$$\Delta T_j = \Delta R_{th} (PC + PS) + R_{th} \left(\frac{\Delta V_F}{V_F} PC + \frac{\Delta Q_{RR}}{Q_{RR}} PS \right)$$

where ΔV_F is the dispersion of the forward voltage and Q_{RR} the dispersion of the reverse recovery charge.

For series operation, it is recommended to use pieces coming from the same lot, so the dispersion on the parameters V_F , Q_{RR} and R_{th} is minimized;

In most cases the evaluation of ΔT_j is difficult but, from experience, it is generally lower than 10°C .

We propose to take a safety margin and to use :

$$\Delta I_R = 0.85 I_{RM}$$

4) Simplified formula

The relation (2) is often used by using the following approximations

$k = 1$: supposing the reverse current I_{RM} constant, whatever the blocking voltage across the diode.

$a = 0$: Neglecting the effect of the tolerance of resistors. thus :

$$R < \frac{n V_{RRM} - V_M}{(n-1) \Delta I_R}$$

As for the ΔI_R the worst case is taken into account.

$\Delta I_R = I_R$ with $I_R = I_R \text{ max at } T_j \text{ max specified } (100^\circ\text{C})$

$$R < \frac{n V_{RRM} - V_M}{(n-1) I_R}$$

This formula is "pessimistic" and induces a low resistance and then a high power dissipation.

5) Example

- Given

Maximum blocking voltage : $V_M = 2500\text{V}$

Part number used : BYT12PI-1000

Power dissipation per diode : $P = 7\text{W}$

Case temperature : $T_{\text{case}} = 52^\circ\text{C}$

- Rectifier specification :

$V_{RRM} = 1000\text{V}$

$I_R \text{ (Max at } T_j = 100^\circ\text{C)} = 2.5\text{mA}$

$R_{th} j-c = 4^\circ\text{C/W}$

- Problem :

Calculation of sharing resistors for 3 diodes in series.

- Solutions :

a) Simplified method :

$$R < \frac{n V_{RRM} - V_M}{(n-1) I_R}$$

With

$$n = 3$$

$$V_{RRM} = 1000\text{V}$$

$$V_M = 2500\text{V}$$

$$I_R = 2.5\text{mA}$$

Thus

$$R_{\text{min}} = 100 \text{ kOhms}$$

Power dissipation per resistor : 3.45 W ! (with duty cycle $\delta = .5$)

b) Calculation with relation (2) :

$$R < \frac{V_{RRM} (V_{RRM} (n+a) - V_M (1+a))}{\Delta I_R V_{RRM} (1+a)(n-1) - I_{RM} (1-k)(1+a)(n V_{RRM} - V_M)}$$

General data for fast rectifiers :

$$\Delta I_R = 0.85 I_{RM}$$

$$k = 0.8$$

Intermediate calculations :

$$T_j = P \cdot R_{th} j-c + T_{\text{case}} = 80^\circ\text{C}$$

APPLICATION NOTE

$$\begin{aligned}
 I_{RM} &= I_{RM}(80^{\circ}\text{C}) \\
 &= I_{RM}(100^{\circ}\text{C}) \exp[-0.0054(100-80)] \\
 &= 0.85\text{mA} \\
 \Delta I_{RM} &= 0.72\text{mA}
 \end{aligned}$$

Assuming we use resistors with 5% of tolerance, then $a = .10$

Let : $R_{min} = 220 \text{ k}\Omega$

Power dissipation per resistor = 1.58W (with $\delta = .5$)

6) Question : is it possible to remove the sharing resistors ?

With the relation (1) we can find the value of V_1 when the value of R tends to be infinite. Then we calculate the condition to have

$$V_1 < V_{RRM}$$

Solving we find

$$\frac{\Delta I_R}{I_{RM}} < \frac{(1-k)(n V_{RRM} - V_M)}{V_{RRM}(n-1)}$$

In the previous example this condition should be

$$\frac{\Delta I_R}{I_{RM}} = 5\%$$

It is obvious that this condition is generally very difficult to meet without hard selection.

II - TRANSIENT VOLTAGE SHARING

1) The problem

When a diode is switched from the forward conduction to the reverse blocking state, a reverse current flows through the device during the reverse recovery time t_{rr} .

After this delay all the charges (minority carriers) stored in the junction are eliminated and the diode turns off. The time integral of the reverse recovery current is called reverse recovery charge (Q_{RR}).

Fig.6 defines the reverse recovery parameters. When a string of n diodes in series switches off, the diode which has the lowest recovery charge turns off first and supports an important proportion of the total voltage V_M . Its maximum reverse voltage V_{RRM} could be reached or exceeded.

Figure 6 : Reverse recovery current waveform.

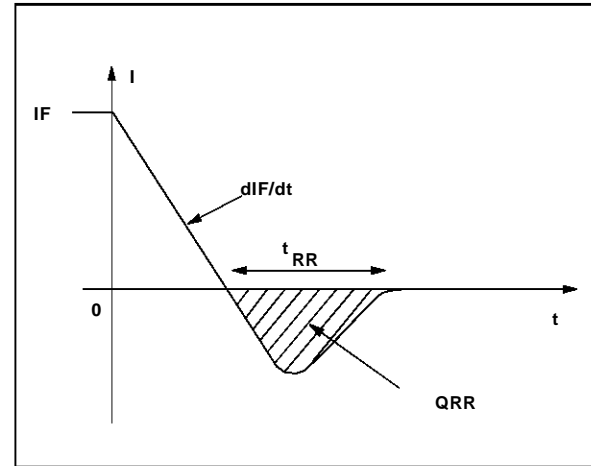

Voltage sharing during the reverse recovery phase is achieved by using a shunt capacitor string connected across the diodes (Fig.7).

Figure 7 : Use of shunt capacitors for transient voltage sharing.

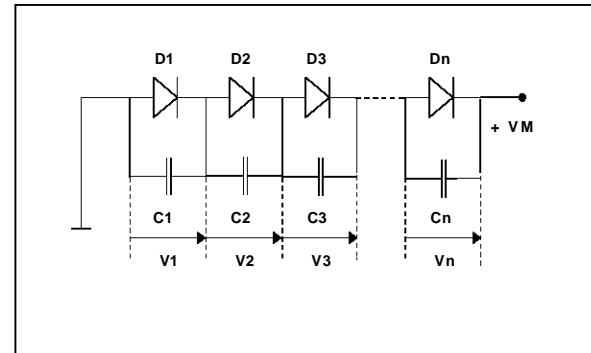

2) Calculation of sharing capacitors

The calculation of capacitance C is also based on the worst case situation.

We assume that $(n-1)$ diodes $D_2, D_3 \dots D_n$ with a reverse recovery charge $Q_{RR} + \Delta Q_{RR}$, and one diode D_1 with lowest value Q_{RR} .

We suppose also that the corresponding capacitor C_1 is at the lowest limit of tolerance (a) while the others are at the upper limit

$$\begin{aligned}
 \text{so : } \quad C_1 &= C \\
 C_2 &= C_3 = \dots = C_n = C(1+a)
 \end{aligned}$$

When all the stored charges of diode D_1 have been evacuated, the charge remaining in the other diodes is ΔQ_{RR} .

At this time the voltage across D_1 is V_1 and the voltage across the other diodes of the string is :

$$V_2 = V_3 = \dots V_n = \frac{V_M - V_1}{(n-1)}$$

So these diodes can be assimilated to a capacitor

$$C_D = \frac{\Delta Q_{RR}}{V_n} = \frac{\Delta Q_{RR} (n-1)}{V_M - V_1}$$

Figure 8 : Equivalent diagram when D1 switches off. Diodes D2, D3, ...Dn are equivalent to a capacitor $C_D = \Delta Q_{RR}(n-1) / (V_M - V_1)$

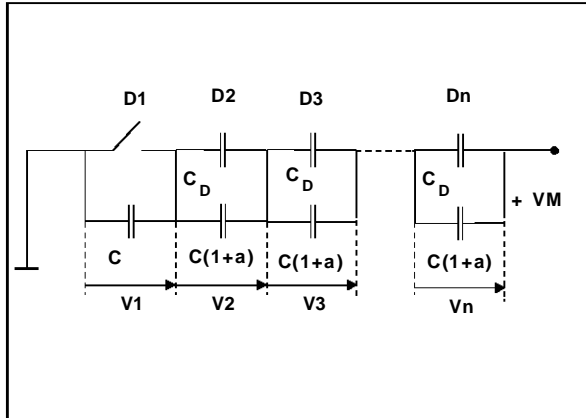

In these conditions the voltage across D1 is :

$$V_1 = \frac{\Delta Q_{RR} (n-1) + C V_M (1+a)}{C (n+a)}$$

In order to limit the voltage across D1 under the specified value V_{RRM} we calculate C by solving thus :

$$C > \frac{(n-1)\Delta Q_{RR}}{(n+a)V_{RRM} - V_M (1+a)}$$

3) QRR and ΔQ_{RR} consideration

For a given diode the reverse recovery charge QRR is a function of the circuit commutation conditions such as the magnitude of forward current (I_F), the rate of decay of this current (dI_F/dt) and the junction temperature.

Typical values of QRR are given in the data sheet of each part number (Fig.9).

Figure 9 : Example of reverse recovery charge specification. (case of BYW 51)

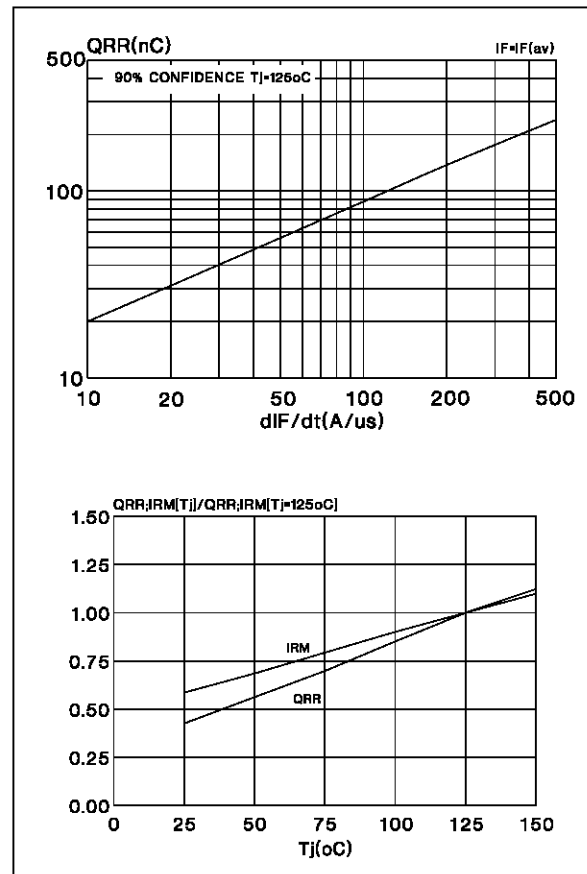

For fast rectifiers coming from the same lot the dispersion of this parameter is low and we can use, with a good safety margin :

$$\Delta Q_{RR} = .30 QRR$$

4) Is it possible to remove the equalizing capacitor ?

In the blocking state, diodes have a junction capacitance. For a given diode this capacitance decreases with an increase in the applied reverse voltage according to Fig.10.

Figure 10 : Junction capacitance versus reverse voltage (example : BYT261PIV-1000)

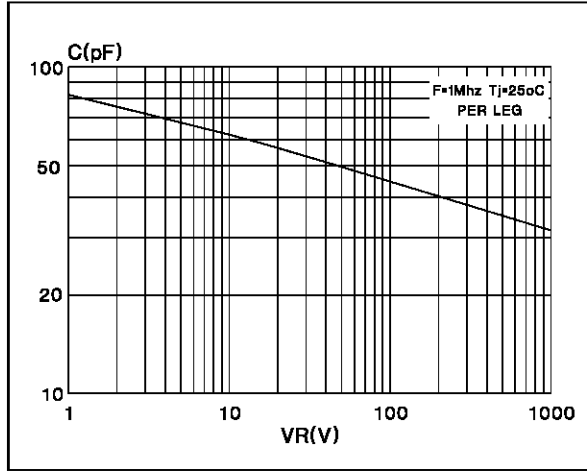

When D1 has evacuated all its stored charge, it is equivalent to a capacitor CJ1 and the other diodes D2, D3 ... Dn are equivalent to a capacitor which is the sum of the junction capacitance CJ2, CJ3 ... CJn and the capacitance

$$C_D = \frac{\Delta Q_{RR} (n-1)}{V_M - V_1}$$

Fig.11 shows the equivalent circuit

Figure 11 : Equivalent diagram when D1 switches off in case of low QRR : The junction capacitances CJ1, CJ2; ...CJn, play the role of sharing capacitors.

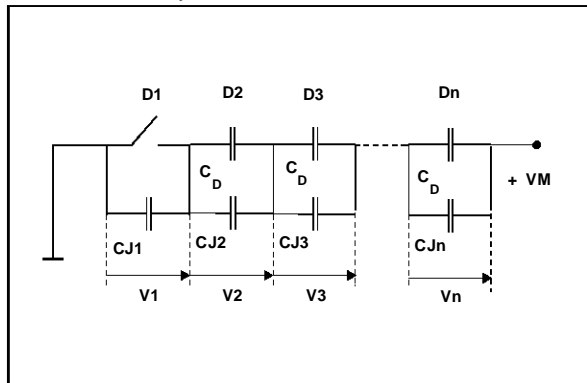

In the worst case CJ1 is the junction capacitor of D1 at the maximum voltage VRRM
Putting

$$C_{J1} = C_J \text{ at } V_{RRM}$$

$$C_{J2} = C_{J3} \dots C_{Jn} = C_J \text{ at } \frac{V_M - V_{RRM}}{n-1}$$

We have

$$V_1 = \frac{\Delta Q_{RR} (n-1) + V_M C_{Jn}}{C_{J1} (n+1) + C_{Jn}}$$

Auxiliary capacitors are not necessary if

$$V_1 < V_{RRM}$$

$$\text{or } \Delta Q_{RR} < \frac{V_{RRM} [C_{J1} (n-1) + C_{Jn}] - V_M C_{Jn}}{n-1}$$

Generally, the value of the junction capacitance at the operating voltage is very close to the value at VRRM (CJ1) so we can write

$$\Delta Q_{RR} < \frac{C_{J1} (n V_{RRM} - V_M)}{n-1}$$

This condition can be met by using very fast rectifiers in applications where the dIF/dt is low (like in some resonant converters or flyback converters) and consequently low QRR.

III - EQUALIZATION BY TRANSIL DIODES

TRANSIL diodes are avalanche diodes designed for operation in breakdown characteristic and they are used as clamping devices in a wide field of applications. To limit the voltage across the rectifiers of a string below the maximum value, TRANSIL diodes can be used according to diagram Fig.12.

Figure 12 : Voltage sharing by TRANSIL diodes.

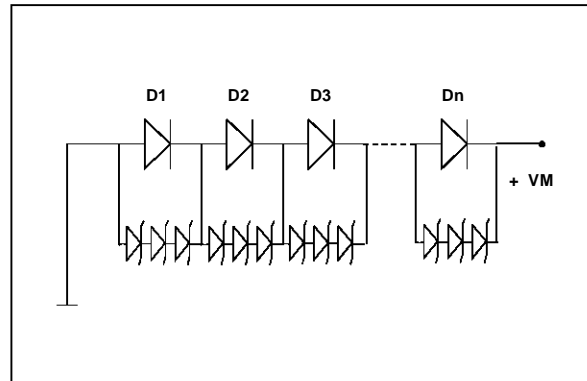

TRANSIL operates as a voltage limiter at steady state, during the switching phase, and also in case of external voltage transients.

1) Steady state

In the blocking condition, the TRANSILS connected across the diode D1 (which has the lowest reverse current) operate in the breakdown

characteristic. The current through these TRANSILS is I_R and the power dissipation is :

$$V_{BR} \cdot \Delta I_R \cdot \delta \quad (\delta = \text{duty cycle})$$

Where V_{BR} is the maximum breakdown voltage of TRANSILS. In general this extra power dissipation is lower than in the case of sharing by resistors and TRANSILS in axial packages can be used.

2) Switching phase

When the fastest diodes of the string switches off, the TRANSILS across it operate in breakdown characteristic, and the reverse recovery current of the other diodes flows through these TRANSILS. The charge remaining in the string at this moment is :

$$(n-1) \Delta Q_{RR}$$

and we can estimate the maximum energy in the TRANSILS with

$$E < 1/2(n-1) \cdot \Delta Q_{RR} \cdot V_{BR}$$

This relation does not take into account the losses due to the capacitive current through the string.

3) Example

GIVEN :

Use of a 3-BYT12PI-1000 for $V_M = 2500V$

Operating conditions :

$$T_j = 100^\circ C$$

$$di/dt = 20A/\mu s$$

$$F = 25 \text{ kHz}$$

$$\delta = .5$$

RECTIFIER SPECIFICATION :

$$V_{RRM} = 1000V$$

$$I_{RM} \text{ at } V_{RRM} = 2.5mA \text{ at } T_j = 100^\circ C$$

$$Q_{RR} = .5\mu C \text{ (in operating conditions)}$$

PROBLEM :

3 TRANSIL diodes are connected in series across each rectifier. What is the suitable part number ?

DESIGN STEPS :

- V_{BR} calculation :

$$V_{BR} \text{ min} > \frac{2500}{3 \times 3} = 277V$$

$$V_{BR} \text{ max} < \frac{1000}{3} = 333V$$

- Power dissipation in steady state :

$$P1 < I_R \cdot V_{BR} \text{ max} \cdot \delta$$

with $I_R = .85 \times 2.5 \approx 2mA$
 $V_{BRmax} = 330V$
 $P1 < 330mW$

- Power dissipation in switching phase :

$$P2 = E \cdot F < 1/2 (n-1) Q_{RR} \cdot V_{BRmax} \cdot F$$

with $\Delta Q_{RR} = .5 \times .3 = .15\mu C$
 $F = 25 \text{ kHz}$ and $n = 3$
then $P2 < 1.2W$

- Max total power dissipation $P1 + P2 = 1.530 W$

Solution : 1.5 KE series can be used (1.5KE300CP)

CONCLUSION

When using several fast rectifiers in series it is necessary to make sure that no diode will be subjected to continuous or transient voltages in excess of their ratings.

In most cases, this is achieved by using sharing networks across each diode. It is important to optimize this circuit in order to reduce power consumption and to save space.

Parallel resistors can be optimized by using the model of the fast recovery diodes reverse characteristic proposed in this paper. Then, thanks to a good knowledge of the reverse current and its variation in the operating conditions (possibly by measurement and selection), it is possible to implement a resistor with a value as high as possible.

Parallel capacitors also have to be reduced as much as possible with the knowledge the switching characteristics of the string in the actual conditions. The reverse recovery charge (Q_{RR}) is not always accessible with the datasheet and a measurement is often necessary.

In certain applications using ultra fast diodes of the same lot, where the Q_{RR} , and therefore the ΔQ_{RR} are very low, the sharing capacitor can be reduced to zero.

In systems where there is a risk of external overvoltages or where there are transient states not well known, TRANSIL diodes are a solution to the sharing voltage problem insofar as the total power dissipation of the TRANSIL string remains compatible with the existing packages for these devices.

References :

1. B.M. BIRD and K.G. KING : "An introduction to Power Electronics"
2. J.M. PETER - SGS-THOMSON Microelectronics : "Analysis and optimisation of high frequency Power rectification"

Information furnished is believed to be accurate and reliable. However, SGS-THOMSON Microelectronics assumes no responsibility for the consequences of use of such information nor for any infringement of patents or other rights of third parties which may result from its use. No license is granted by implication or otherwise under any patent or patent rights of SGS-THOMSON Microelectronics. Specifications mentioned in this publication are subject to change without notice. This publication supersedes and replaces all information previously supplied.

SGS-THOMSON Microelectronics products are not authorized for use as critical components in life support devices or systems without express written approval of SGS-THOMSON Microelectronics.

© 1995 SGS-THOMSON Microelectronics - Printed in Italy - All rights reserved.

SGS-THOMSON Microelectronics GROUP OF COMPANIES

Australia - Brazil - France - Germany - Hong Kong - Italy - Japan - Korea - Malaysia - Malta - Morocco -
The Netherlands - Singapore - Spain - Sweden - Switzerland - Taiwan - Thailand - United Kingdom - U.S.A.



LittleDiode supplies new, hard to find or obsolete electronic components and semiconductors all over the world.

With over two million different components listed you are sure to find the part you need.

Feel free to visit us today at our online store:

LittleDiode.com

Looking forward to providing you with the best possible service.