

DATA SHEET

Part No.	AN41023A
Package Code No.	HSOP042-P-0400D

Contents

■ Overview	3
■ Features	3
■ Applications	3
■ Package	3
■ Type	3
■ Application Circuit Example	4
■ Pin Descriptions	5
■ Absolute Maximum Ratings	6
■ Operating Supply Voltage Range	6

Maintenance/Discontinued includes following four Product lifecycle stage
Discontinued
planned maintenance type
maintenance type
planned discontinued type
discontinued type
Please visit following URL about latest information.
<http://www.semicon.panasonic.co.jp/en/>

AN41023A

4.5-ch. linear driver IC for CD, MD and DVD Player

■ Overview

AN41023A is a 4.5-ch. Linear driver IC incorporating the high-power operational amplifier system and suitable for CD and MD actuator and motor driver applications.

(ch.1 & ch.2: Actuator, ch.3: Spindle, ch.4A: Traverse, ch.4B: Loading)

■ Features

- Wide output dynamic range: Maximum output voltage of 6 V(typ.) when $S_{V_{CC}} = P_{V_{CC}} = 8\text{ V}$ and $R_L = 8\Omega$
- Built-in general purpose operational amplifier in each input part of ch.1, ch.2, ch.3 and ch.4A, and compatible for both linear input and PWM input.
- Built-in a channel switching, ch.4A for traverse and ch.4B for loading.
- Selectable loading mode among forward, reverse, brake and stand-by by the digital signal from a microcomputer.
- Built-in stand-by function.
- Built-in thermal shutdown circuit.

■ Applications

- CD, MD and DVD-Player actuator and motor driver applications.

■ Package

- 28-pin plastic small outline package with heat slug (SOP type)

■ Type

- Silicon monolithic bipolar IC

■ Application Circuit Example

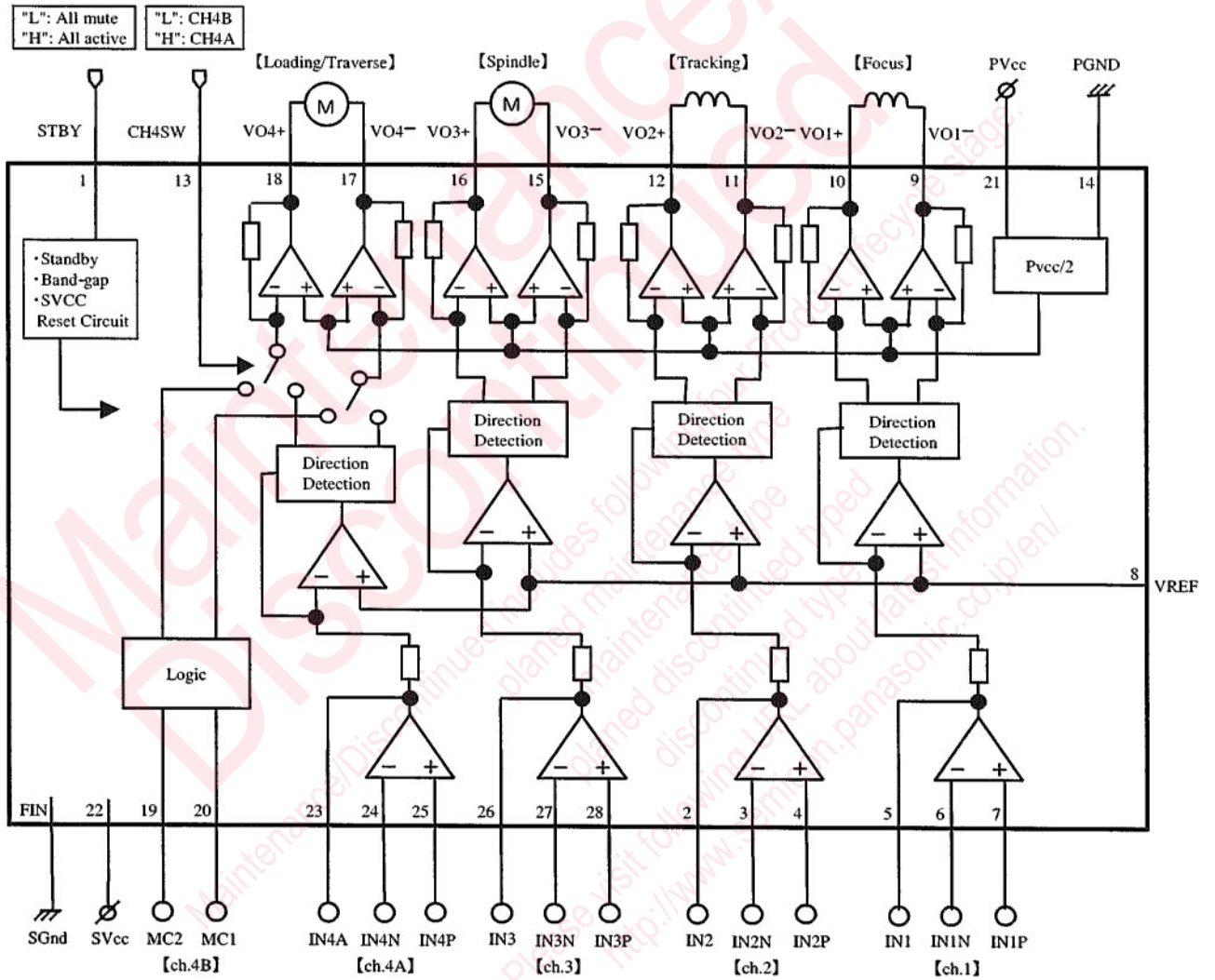

■ Pin Descriptions

Pin No.	Pin name	Type	Description
1	STBY	Input	Stand-by input
2	IN2	Input	Driver 2 input
3	IN2N	Input	Driver 2 negative input
4	IN2P	Input	Driver 2 positive input
5	IN1	Input	Driver 1 input
6	IN1N	Input	Driver 1 negative input
7	IN1P	Input	Driver 1 positive input
8	VREF	Input	VREF input
9	VO1-	Output	Driver 1 negative output
10	VO1+	Output	Driver 1 positive output
11	VO2-	Output	Driver 2 negative output
12	VO2+	Output	Driver 2 positive output
13	CH4SW	Input	CH4 input select
14	PGND	Ground	Ground for driver
15	VO3-	Output	Driver 3 negative output
16	VO3+	Output	Driver 3 positive output
17	VO4-	Output	Driver 4 negative output
18	VO4+	Output	Driver 4 positive output
19	MC2	Input	MC2 input
20	MC1	Input	MC1 input
21	PV _{CC}	Power supply	Power supply for diver
22	SV _{CC}	Power supply	Power supply
23	IN4A	Input	Driver 4 input
24	IN4N	Input	Driver 4 negative input
25	IN4P	Input	Driver 4 positive input
26	IN3	Input	Driver 3 input
27	IN3N	Input	Driver 3 negative input
28	IN3P	Input	Driver 3 positive input
FIN	SGND	Ground	Ground

■ Absolute Maximum Ratings

A No.	Parameter	Symbol	Rating	Unit	Notes
1	Supply voltage	SV_{CC} PV_{CC}	14	V	*1
2	Supply voltage	ISV_{CC} IPV_{CC}	0.2 1.2	A	*2
3	Power dissipation	P_D	582	mW	*3
4	Operating ambient temperature	T_{opr}	-40 to +85	°C	*4
5	Storage temperature	T_{stg}	-55 to +150	°C	*4
6	Supply voltage application range	V_{CC}	-0.3 to +14.0	V	—
7	Driver output current	$I_{O(n)}$	±1.0	A	*5
8	Control signal input voltage	V_n	0 to SV_{CC}	V	*6

Notes) *1 : The values under the condition not exceeding the above absolute maximum ratings and the power dissipation.

*2 : Make sure that all channels operate within 1 A current flow.

*3 : The power dissipation shown is the value at $T_a = 85^\circ\text{C}$ for the independent (unmounted) IC package with out a heat sink.

When using this IC, refer to the P_D - T_a diagram of the package standard page 4 and use under the condition not exceeding the allowable value.

*4 : Except for the power dissipation, operating ambient temperature, and storage temperature, all ratings are for $T_a = 25^\circ\text{C}$.

*5 : At $I_{O(n)}$, "n" is Pin No., n = 9, 10, 11, 12, 15, 16, 17, 18.

Do not apply current or voltage from external sources to any pin not listed above. For the current denotation, (+) means current flowing into IC (-) means current flowing out from IC.

*5 : At $I_{O(n)}$, "n" is Pin No., n = 1, 2, 3, 4, 5, 6, 7, 8, 13, 19, 20, 23, 24, 25, 26, 27, 28.

Do not apply current or voltage from external sources to any pin not listed above. For the current denotation, (+) means current flowing into IC (-) means current flowing out from IC.

■ Operating supply voltage range

Parameter	Symbol	Rangs	Unit	Notes
Supply voltage range	SV_{CC} PV_{CC}	4.5 to 13.5	V	*

Note) * : Operate on the condition $PV_{CC} \leq SV_{CC}$

The values under the condition not exceeding the above absolute maximum ratings and the power dissipation.

Request for your special attention and precautions in using the technical information and semiconductors described in this book

- (1) If any of the products or technical information described in this book is to be exported or provided to non-residents, the laws and regulations of the exporting country, especially, those with regard to security export control, must be observed.
- (2) The technical information described in this book is intended only to show the main characteristics and application circuit examples of the products, and no license is granted under any intellectual property right or other right owned by our company or any other company. Therefore, no responsibility is assumed by our company as to the infringement upon any such right owned by any other company which may arise as a result of the use of technical information described in this book.
- (3) The products described in this book are intended to be used for standard applications or general electronic equipment (such as office equipment, communications equipment, measuring instruments and household appliances).
Consult our sales staff in advance for information on the following applications:
 - Special applications (such as for airplanes, aerospace, automobiles, traffic control equipment, combustion equipment, life support systems and safety devices) in which exceptional quality and reliability are required, or if the failure or malfunction of the products may directly jeopardize life or harm the human body.
 - Any applications other than the standard applications intended.
- (4) The products and product specifications described in this book are subject to change without notice for modification and/or improvement. At the final stage of your design, purchasing, or use of the products, therefore, ask for the most up-to-date Product Standards in advance to make sure that the latest specifications satisfy your requirements.
- (5) When designing your equipment, comply with the range of absolute maximum rating and the guaranteed operating conditions (operating power supply voltage and operating environment etc.). Especially, please be careful not to exceed the range of absolute maximum rating on the transient state, such as power-on, power-off and mode-switching. Otherwise, we will not be liable for any defect which may arise later in your equipment.
 - Even when the products are used within the guaranteed values, take into the consideration of incidence of break down and failure mode, possible to occur to semiconductor products. Measures on the systems such as redundant design, arresting the spread of fire or preventing glitch are recommended in order to prevent physical injury, fire, social damages, for example, by using the products.
- (6) Comply with the instructions for use in order to prevent breakdown and characteristics change due to external factors (ESD, EOS, thermal stress and mechanical stress) at the time of handling, mounting or at customer's process. When using products for which damp-proof packing is required, satisfy the conditions, such as shelf life and the elapsed time since first opening the packages.
- (7) This book may be not reprinted or reproduced whether wholly or partially, without the prior written permission of Matsushita Electric Industrial Co., Ltd.



LittleDiode supplies new, hard to find or obsolete electronic components and semiconductors all over the world.

With over two million different components listed you are sure to find the part you need.

Feel free to visit us today at our online store:

LittleDiode.com

Looking forward to providing you with the best possible service.