

# AN3969K

## Electronic volume IC for HiFi VCR

### ■ Overview

The AN3969K is a stereo electronic volume IC which has been developed for a HiFi video, enabling to switch four inputs of a single channel and to input from microphone.

### ■ Features

- Both L/R-independent volume control and balance control are available
- Switching four inputs with a single channel is possible
- Electronic volume off function
- Mic. mixing function

### ■ Applications

- HiFi VCR

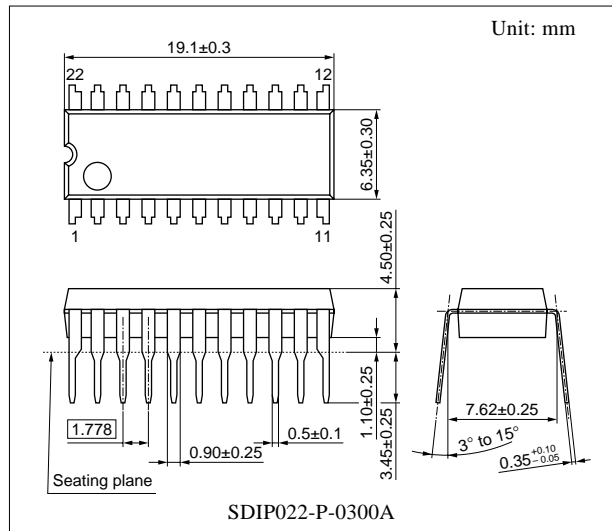

■ Block Diagram

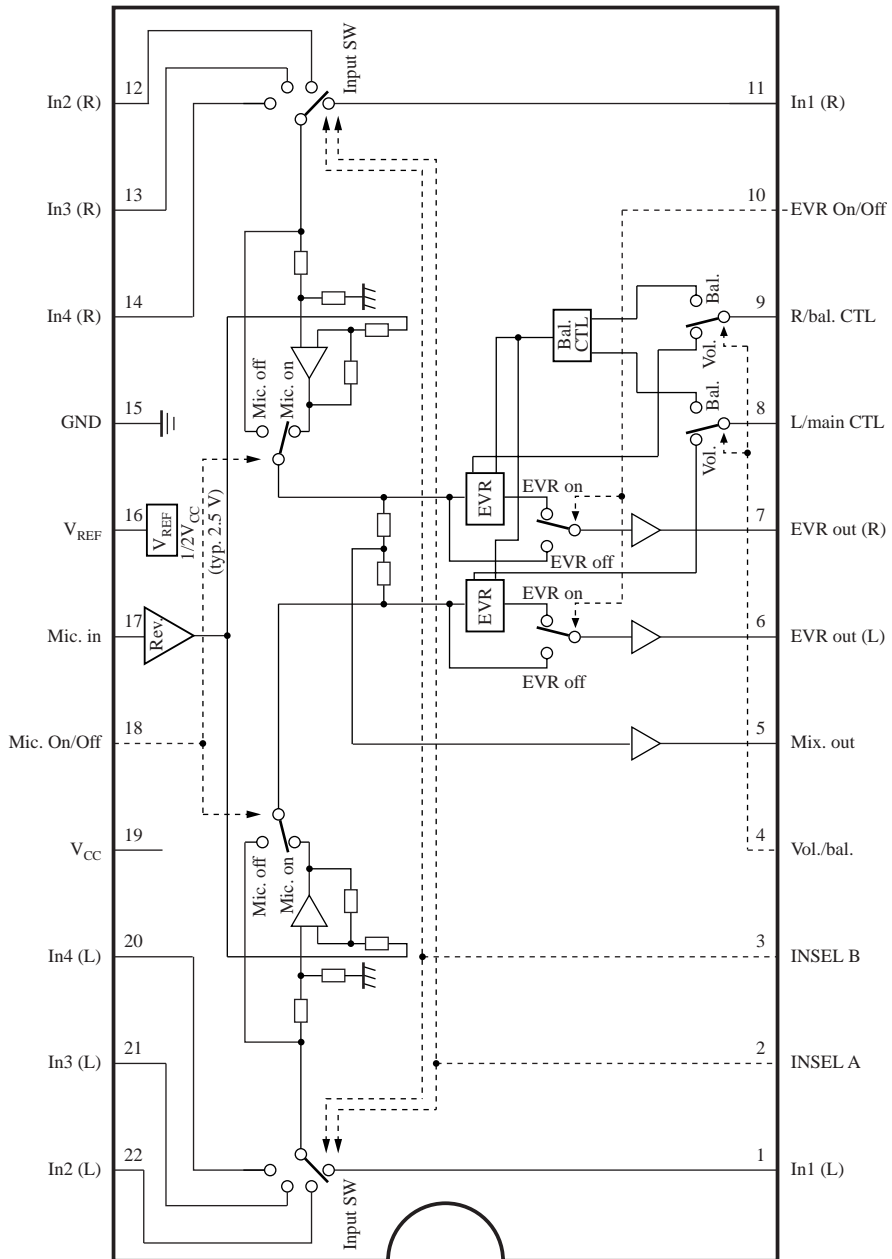

### ■ Pin Descriptions

Pin No.	Description	Pin No.	Description
1	In1 (L-ch.) input pin	11	In1 (R-ch.) input pin
2	Input selection control (CTL) A pin	12	In2 (R-ch.) input pin
3	Input selection control (CTL) B pin	13	In3 (R-ch.) input pin
4	EVR individual/balance mode CTL pin	14	In4 (R-ch.) input pin
5	Mix. output pin	15	GND pin
6	EVR (L-ch.) output pin	16	V <sub>REF</sub> (1/2V <sub>CC</sub> ) pin
7	EVR (R-ch.) output pin	17	Mic. input pin
8	Main volume adjustment pin for individual mode L-ch./balance mode	18	Mic. On/Off CTL pin
		19	V <sub>CC</sub> (5 V) pin
9	Balance volume adjustment pin for individual mode R-ch./balance mode	20	In4 (L-ch.) input pin
		21	In3 (L-ch.) input pin
10	EVR On/Off CTL pin	22	In2 (L-ch.) input pin

### ■ Absolute Maximum Ratings

Parameter	Symbol	Rating	Unit
Supply voltage	V <sub>CC</sub>	6.0	V
Power dissipation *1, *2	P <sub>D</sub>	186	mW
Operating ambient temperature *1	T <sub>opr</sub>	-20 to +75	°C
Storage temperature *1	T <sub>stg</sub>	-55 to +150	°C

Note) \*1: Except for the power dissipation, operating ambient temperature and storage temperature, all ratings are for T<sub>a</sub> = 25°C.

\*2: The power dissipation shown is the value for T<sub>a</sub> = 75°C.

### ■ Recommended Operating Range

Parameter	Symbol	Range	Unit
Supply voltage	V <sub>CC</sub>	4.5 to 5.5	V

### ■ Electrical Characteristics at V<sub>CC</sub> = 5 V, pin 8 = 3 V, pin 9 = 3 V, T<sub>a</sub> = 25°C

Parameter	Symbol	Conditions	Min	Typ	Max	Unit
Circuit current 1	I <sub>VOL</sub>	EVR individual CTL mode with no signal	14	18	23	mA
Circuit current 2	I <sub>BAL</sub>	EVR balance mode with no signal	19	25	31	mA
EVR out level L	VEO <sub>L</sub>	Typical input	-23	-20	-17	dBs
EVR out level R	VEO <sub>R</sub>	Typical input	-23	-20	-17	dBs
EVR out distortion ratio L	TEO <sub>L</sub>	Typical input	—	—	0.2	%
EVR out distortion ratio R	TEO <sub>R</sub>	Typical input	—	—	0.2	%

Note) 1. Unless otherwise specified, set a mode to In1 input selection, EVR on, EVR individual CTL, mic. off and input a typical input that is In1 input, V<sub>IN</sub> = -20 dBs, f<sub>IN</sub> = 1 kHz and L/R simultaneous input.

2. Unless otherwise specified, measure EVR out L for L-ch. parameter and EVR out R for R-ch. parameter.

**■ Electrical Characteristics at  $V_{CC} = 5\text{ V}$ , pin 8 = 3 V, pin 9 = 3 V,  $T_a = 25^\circ\text{C}$  (continued)**

Parameter	Symbol	Conditions	Min	Typ	Max	Unit
EVR out max. output L	VEOM <sub>L</sub>	Output level at pin 8 = 5 V and distortion ratio = 1%	1	—	—	dBs
EVR out max. output R	VEOM <sub>R</sub>	Output level at pin 9 = 5 V and distortion ratio = 1%	1	—	—	dBs
EVR out S/N L	NEO <sub>L</sub>	Ratio to VEO <sub>L</sub> to In1, R <sub>G</sub> = 18 k $\Omega$ , JIS A and R <sub>L</sub> = 10 k $\Omega$	70	—	—	dB
EVR out S/N R	NEO <sub>R</sub>	Ratio to VEO <sub>R</sub> to In1, R <sub>G</sub> = 18 k $\Omega$ , JIS A and R <sub>L</sub> = 10 k $\Omega$	70	—	—	dB
EVR max. level L	VMAX <sub>L</sub>	Ratio to VEO <sub>L</sub> with typical input and pin 8 = 5 V	8	10	12	dB
EVR max. level R	VMAX <sub>R</sub>	Ratio to VEO <sub>R</sub> with typical input and pin 9 = 5 V	8	10	12	dB
EVR attenuation level L	VMIN <sub>L</sub>	Ratio to output with V <sub>IN</sub> = -10 dBs, pin 8 = 0 V and pin 8 = 3 V	—	—	-65	dB
EVR attenuation level R	VMIN <sub>R</sub>	Ratio to output with V <sub>IN</sub> = -10 dBs, pin 9 = 0 V and pin 9 = 3 V	—	—	-65	dB
EVR balance characteristics 1-L	VBAL <sub>1L</sub>	EVR balance mode, pin 8 = 5 V, pin 9 = 2.5 V	-12	-10	-8	dBs
EVR balance characteristics 1-R	VBAL <sub>1R</sub>	EVR balance mode, pin 8 = 5 V, pin 9 = 2.5 V	-12	-10	-8	dBs
EVR balance characteristics 2-L	VBAL <sub>2L</sub>	EVR balance mode, pin 8 = 5 V, pin 9 = 1.25 V, ratio to VBAL <sub>1L</sub>	-12	-10	-7	dB
EVR balance characteristics 2-R	VBAL <sub>2R</sub>	EVR balance mode, pin 8 = 5 V, pin 9 = 3.75 V, ratio to VBAL <sub>1R</sub>	-12	-10	-7	dB
EVR balance characteristics 3-L	VBAL <sub>3L</sub>	EVR balance mode, pin 8 = 5 V, pin 9 = 0 V, ratio to VBAL <sub>1L</sub>	—	—	-50	dB
EVR balance characteristics 3-R	VBAL <sub>3R</sub>	EVR balance mode, pin 8 = 5 V, pin 9 = 5 V, ratio to VBAL <sub>1R</sub>	—	—	-50	dB
Mix. out level	VMIX	Mix. out measurement in a typical input	-22	-20	-18	dBs
Mix. out distortion ratio	TMIX	Mix. out measurement in a typical input	—	—	0.2	%
Mic. mix. level	VMIC	Mix. out measurement with mic. on mode, mic in = -32 dBs, 1 kHz	-22	-20	-18	dBs
Mic. mix. muting ratio	VMUTE	Mic. off mode, mic. <sub>IN</sub> = -32 dBs, 1 kHz, mix. out measurement, ratio to VMIC	—	—	-70	dB
Crosstalk 1 between channels (R→L)	CCH1 <sub>RL</sub>	In1R = -10 dBs, L-ch. measurement, DIN audio, ratio to VEO <sub>L</sub> is -10 dB.	—	—	-75	dB
Crosstalk 2 between channels (L→R)	CCH1 <sub>LR</sub>	In1L = -10 dBs, R-ch. measurement, DIN audio, ratio to VEO <sub>R</sub> is -10 dB.	—	—	-75	dB
Crosstalk between inputs	CIN1	In2, In3, In4 = -10 dBs, mix. measurement, DIN audio, ratio to VMIX is -10 dB.	—	—	-60	dB

Note) 1. Unless otherwise specified, set a mode to In1 input selection, EVR on, EVR individual CTL, mic. off and input a typical input that is In1 input, V<sub>IN</sub> = -20 dBs, f<sub>IN</sub> = 1 kHz and L/R simultaneous input.

2. Unless otherwise specified, measure EVR out L for L-ch. parameter and EVR out R for R-ch. parameter.

■ Electrical Characteristics at  $V_{CC} = 5\text{ V}$ , pin 8 = 3 V, pin 9 = 3 V,  $T_a = 25^\circ\text{C}$  (continued)

• Design reference data

Note) The characteristics listed below are theoretical values based on the IC design and are not guaranteed.

Parameter	Symbol	Conditions	Min	Typ	Max	Unit
Input selection CTL A (low) *	DINA <sub>L</sub>	Pin 2 input	0	—	1.5	V
Input selection CTL A (high) *	DINA <sub>H</sub>	Pin 2 input	3.5	—	5	V
Input selection CTL B (low) *	DINB <sub>L</sub>	Pin 3 input	0	—	1.5	V
Input selection CTL B (high) *	DINB <sub>H</sub>	Pin 3 input	3.5	—	5	V
EVR individual CTL mode	DVOLL	Pin 4 input (low)	0	—	1.5	V
EVR balance mode	DBALH	Pin 4 input (high)	3.5	—	5	V
EVR on mode	DEONL	Pin 10 input (low)	0	—	1.5	V
EVR off mode	DEOFFH	Pin 10 input (high)	3.5	—	5	V
Mic. on mode	DMONL	Pin 18 input (low)	0	—	1.5	V
Mic. off mode	DMOFFH	Pin 18 input (high)	3.5	—	5	V
EVR out L/R difference	VEOLR	Typical input, pin 8, pin 9 = 3 V, ratio of EVR out L to R	—	0	—	dB
EVR off level L	VEOFFL	EVR off mode, typical input, EVR out L measurement	—	-20	—	dBs
EVR off level R	VEOFFR	EVR off mode, typical input, EVR out R measurement	—	-20	—	dBs

Note) 1. Typical input = (In1 input,  $V_{IN} = -20\text{ dBs}$ ,  $f_{IN} = 1\text{ kHz}$ , L/R simultaneous input)

2. \*: In1 input selection mode: pin 2 = low, pin 3 = low, In2 input selection mode: pin 2 = high, pin 3 = low

In3 input selection mode: pin 2 = low, pin 3 = high, In4 input selection mode: pin 2 = high, pin 3 = high

■ Terminal Equivalent Circuits

Pin No.	Equivalent circuit	Description	Pin voltage (typ) (V)
1		In1(L-ch.) input: Audio signal Typical = -20 dBs (1 kHz)	2.5

■ Terminal Equivalent Circuits (continued)

Pin No.	Equivalent circuit	Description	Pin voltage (typ) (V)
<p>2 3</p>		<p>Pin 2: input selection CTL A; Pin 3: input selection CTL B</p>	<p>—</p>
<p>4</p>		<p>Vol./bal. CTL</p>	<p>—</p>
<p>5 6 7</p>		<p>Pin 5: mix. input; Pin 6: EVR (L-ch.) output; Pin 7: EVR (R-ch.) output</p>	<p>2.5</p>
<p>8</p>		<p>L-ch. CTL (individual mode) Main CTL (balance mode)</p>	<p>—</p>

■ Terminal Equivalent Circuits (continued)

Pin No.	Equivalent circuit	Description	Pin voltage (typ) (V)
9		R-ch. CTL (individual mode) Balance CTL (balance mode)	—
10		EVR On/Off CTL	—
11 12 13 14	Refer to pin 1.	Pin 11: In1 (R-ch.) input; Pin 12: In2 (R-ch.) input; Pin 13: In3 (R-ch.) input; Pin 14: In4 (R-ch.) input	Refer to pin 1.
15	—	GND	0
16		$V_{REF}$	2.5
17		Mic. input	2.5

### ■ Terminal Equivalent Circuits (continued)

Pin No.	Equivalent circuit	Description	Pin voltage (typ) (V)
18		Mic. On/Off CTL	—
19	—	$V_{CC}$	5
20	Refer to pin 1.	Pin 20: In4 (L-ch.) input;	Refer to pin 1.
21	Refer to pin 1.	Pin 21: In3 (L-ch.) input;	
22	Refer to pin 1.	Pin 22: In2 (L-ch.) input	

■ Application Circuit Example

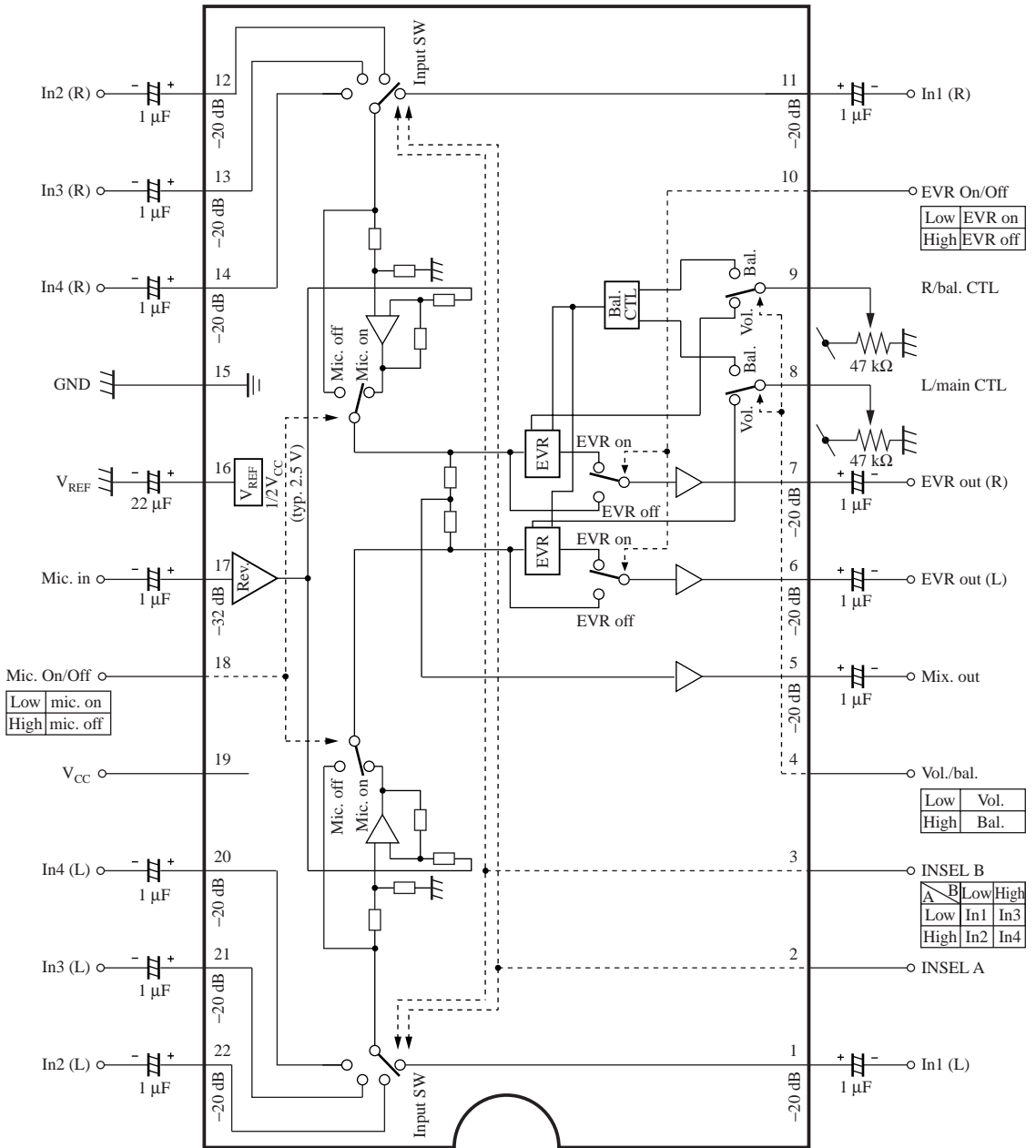



LittleDiode supplies new, hard to find or obsolete electronic components and semiconductors all over the world.

With over two million different components listed you are sure to find the part you need.

Feel free to visit us today at our online store:

[LittleDiode.com](http://LittleDiode.com)

Looking forward to providing you with the best possible service.