

AN3900NSC

Stereo Audio PLL IC for 8-mm Video Camera

Overview

The AN3900NSC is a PLL IC to process 8-mm VCR stereo audio signals. It incorporates limiter amplifiers, frequency dividers, phase comparators, quartz oscillator circuits, and other functions necessary for frequency adjustment of MHz-band signals. It may be used with the AN3986FHP or the AN3986FBP to form a complete system.

Features

- Compatible with 3 modes of NTSC, PAL, and XT standards
- Built-in a quartz oscillator circuit

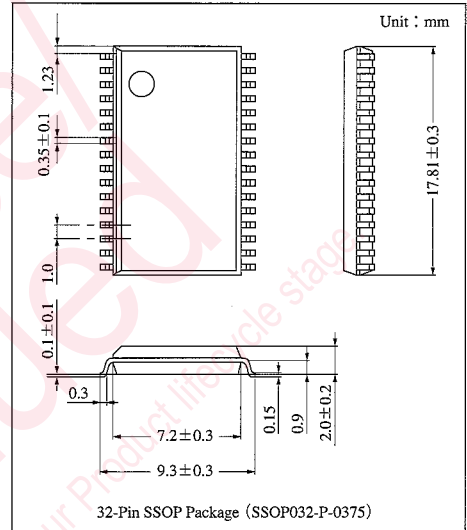

Block Diagram

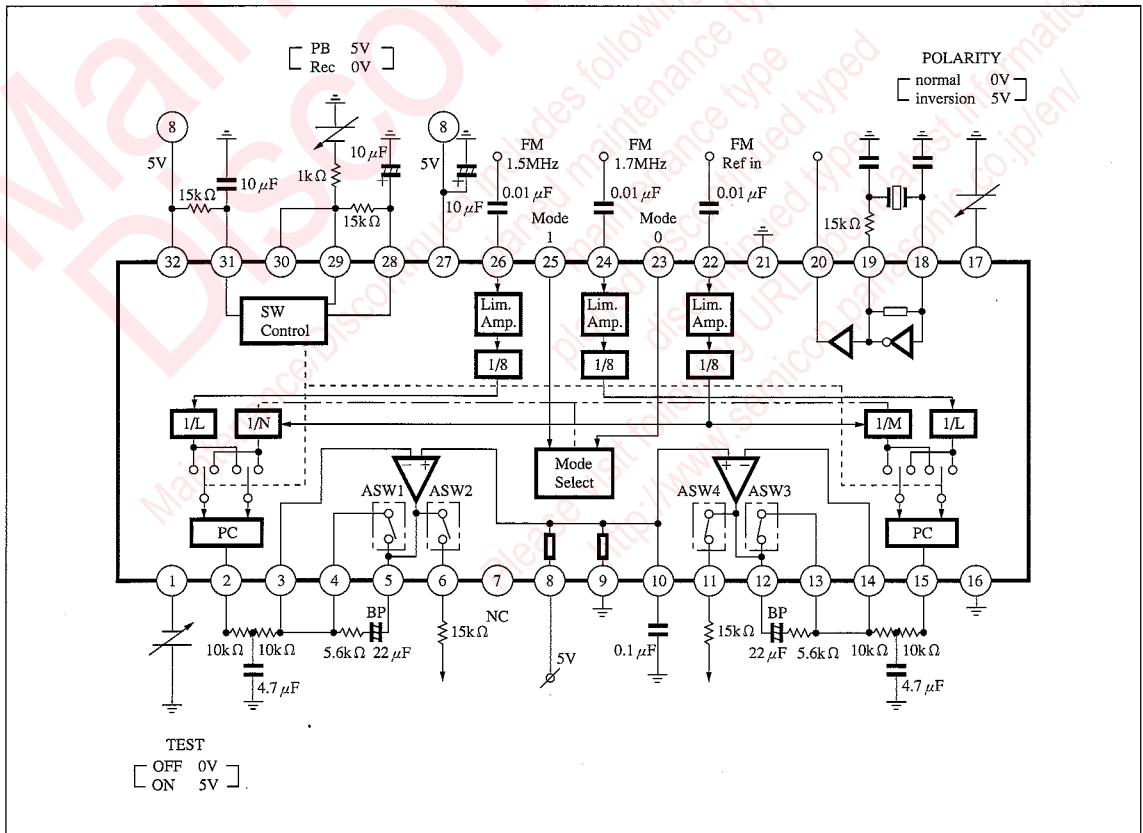

ICs for VCR

Pin Descriptions

Pin No.	Pin name	Pin No.	Pin name
1	Test mode input	17	Polarity switching
2	Phase comparator output (L channel)	18	Crystal oscillator input
3	Filter amplifier reverse input (L channel)	19	Crystal oscillator output
4	Analog switch output (L channel)	20	Buffered oscillator output
5	Filter amplifier output (L channel)	21	Ground for ECL
6	PLL error output (L channel)	22	Reference input
7	No connection	23	MODE 0
8	V _{CC} for analog circuits (5V)	24	R channel FM modulation input
9	GND for analog circuits	25	MODE 1
10	Connecting to a pass-capacitor for ope. amp. bias	26	L channel FM modulation input
11	PLL error output (R channel)	27	V _{CC} for ECL (5V)
12	Filter OP. AMP output (R channel)	28	Time-constant input (playback/recording switching)
13	Analog switch output (R channel)	29	VAPB mode
14	Filter OP. AMP reverse input (R channel)	30	Standby mode
15	Phase comparator output (R channel)	31	Time-constant input (at power-on)
16	Ground for I ² L	32	V _{CC} for PLL

Absolute Maximum Ratings

Parameter	Symbol	Rating	Unit
Supply voltage	V _{CC}	6	V
Power dissipation ^{Note2)}	P _D	323	mW
Operating ambient temperature ^{Note1)}	T _{opr}	-20 to +70	°C
Storage temperature ^{Note1)}	T _{stg}	-55 to +125	°C

Note 1) T_a = 25°C except operating ambient temperature and storage temperature.

Note 2) Allowable power dissipation of the package at T_a = 70°C.

Recommended Operating Range (T_a = 25°C)

Parameter	Symbol	Range
Operating supply voltage range	V _{CC}	4.5V to 5.5V

Reference

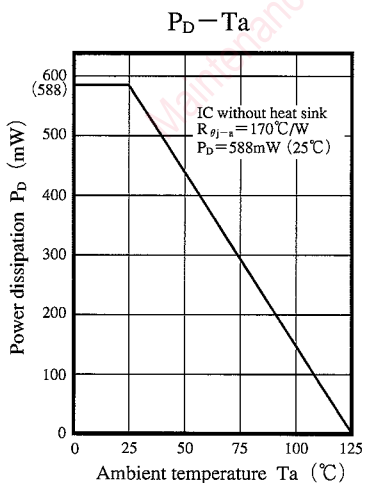









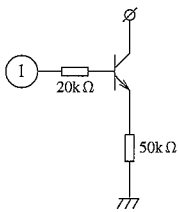
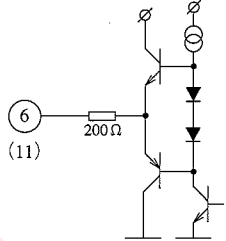

Electrical Characteristics ($V_{CC}=5.0V$, $T_a=25\pm 2^\circ C$)

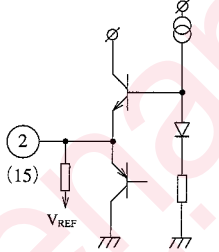
Parameter	Symbol	Condition	min	typ	max	Unit
Circuit current at recording	I_{8R}	$V_{CC}=5.0V$ $Pin\textcircled{28}, \textcircled{29}, \textcircled{30}=0V$	21	29	37	mA
Supply current at PB mode	I_{8P}	$V_{CC}=5.0V$ $Pin\textcircled{28}, \textcircled{29}, \textcircled{30}=5.0V$	12	17	22	mA
NTSC VCO frequency error (R)	FV_{NR}	$Pin\textcircled{22} f=3.579MHz$ $V_{IN}=400mV_{P-P}$	-1.0	—	1.0	kHz
NTSC VCO frequency error (L)	FV_{NL}	$Pin\textcircled{22} f=3.579MHz$ $V_{IN}=400mV_{P-P}$	-1.0	—	1.0	kHz
PAL VCO frequency error (R)	FV_{PR}	$Pin\textcircled{22} f=4.4336MHz$ $V_{IN}=400mV_{P-P}$	-1.0	—	1.0	kHz
PAL VCO frequency error (L)	FV_{PL}	$Pin\textcircled{22} f=4.4336MHz$ $V_{IN}=400mV_{P-P}$	-1.0	—	1.0	kHz
XT VCO frequency error (R)	FV_{XR}	$Pin\textcircled{22} f=0.1494MHz$ $V_{IN}=3V_{P-P}$	-1.0	—	1.0	kHz
XT VCO frequency error (L)	FV_{XL}	$Pin\textcircled{22} f=0.1494MHz$ $V_{IN}=3V_{P-P}$	-1.0	—	1.0	kHz
NTSC Rch reference signal level	RL_{NR}	$Pin\textcircled{22} f=3.579MHz$ VCO frequency error < 1kHz	0.09	—	4.0	V_{P-P}
NTSC Lch reference signal level	RL_{NL}	$Pin\textcircled{22} f=3.579MHz$ VCO frequency error < 1kHz	0.09	—	4.0	V_{P-P}
PAL Rch reference signal level	RL_{PR}	$Pin\textcircled{22} f=4.4336MHz$ VCO frequency error < 1kHz	0.09	—	4.0	V_{P-P}
PAL Lch reference signal level	RL_{PL}	$Pin\textcircled{22} f=4.4336MHz$ VCO frequency error < 1kHz	0.09	—	4.0	V_{P-P}
XT Rch reference signal level	RL_{XR}	$Pin\textcircled{22} f=0.1494MHz$ VCO frequency error < 1kHz	2.0	—	4.0	V_{P-P}
XT Lch reference signal level	RL_{XL}	$Pin\textcircled{22} f=0.1494MHz$ VCO frequency error < 1kHz	2.0	—	4.0	V_{P-P}
Rec holding voltage	V_{R28-30}		0.0	—	1.3	V
PB holding voltage	V_{P28-30}		3.7	—	5.0	V
Demodulation noise level (R)	NL_R	$Pin\textcircled{22} f=3.579MHz$ $V_{IN}=400mV_{P-P}$	—	—	-63	dBv
Demodulation noise level (L)	NL_L	$Pin\textcircled{22} f=3.579MHz$ $V_{IN}=400mV_{P-P}$	—	—	-63	dBv
Quartz oscillation output level	L_{OSC}	Quartz oscillator, at $f=3.579MHz$	0.3	—	—	V_{P-P}
NTSC/PAL/XT change-over voltage NTSC	V_{N23}	$Pin\textcircled{25}=0V$	0	—	1.3	V
NTSC/PAL/XT change-over voltage NTSC (2)	V_{N25}	$Pin\textcircled{23}=0V$	0	—	1.3	V
NTSC/PAL/XT change-over voltage PAL (1)	V_{P23}	$Pin\textcircled{25}=0V$	3.7	—	5.0	V
NTSC/PAL/XT change-over voltage PAL (2)	V_{P25}	$Pin\textcircled{23}=5.0V$	0	—	1.3	V
NTSC/PAL/XT change-over voltage XT (1)	V_{X23}	$Pin\textcircled{25}=5.0V$	0	—	1.3	V
NTSC/PAL/XT change-over voltage XT (2)	V_{X25}	$Pin\textcircled{23}=0V$	3.7	—	5.0	V
Polarity inversion change-over input voltage High	V_{H17}		3.7	—	5.0	V
Polarity inversion change-over input voltage Low	V_{L17}		0	—	1.3	V
TEST mode input voltage High	V_{H1}		3.7	—	5.0	V
TEST mode input voltage Low	V_{L1}		0	—	1.3	V

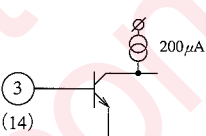
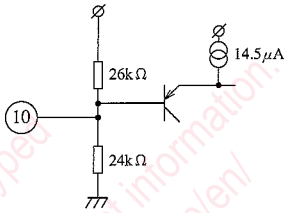
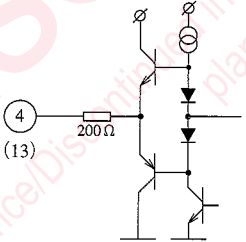
 ICs for
VCR

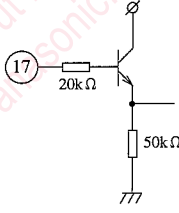
Pin Descriptions

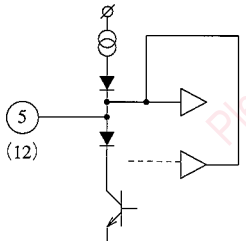

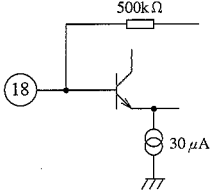





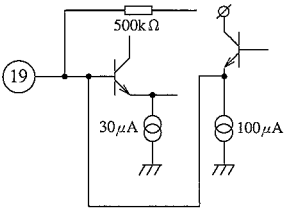

Waveform and input/output equivalent circuit at each pin (V_{CC} and GND not shown)

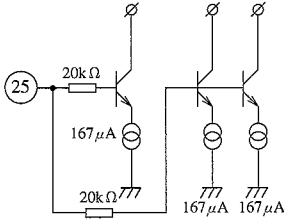
Pin No.	Waveform · Voltage	Equivalent circuit	Pin No.	Waveform · Voltage	Equivalent circuit
1			6 11	DC2.4V	
2 15	 DC2.4V		7	NC	
3 14	DC2.4V		10	DC2.4V	
4 13	DC2.4V		17		
5 12	 DC2.4V		18	 DC2.4V	

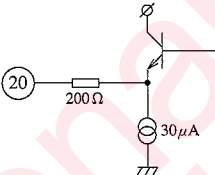
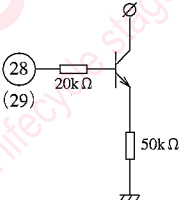
Note) The above values are typical ones (at $V_{CC}=5.0V$) and may depend on the operating condition and individual IC.

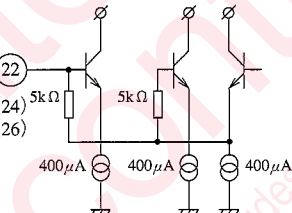
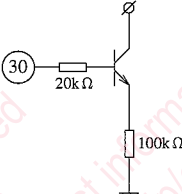
■ Pin Descriptions (cont.)

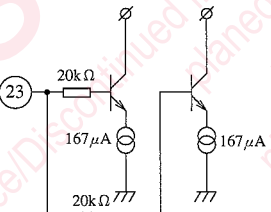
Waveform and input/output equivalent circuit at each pin (V_{CC} and GND not shown)

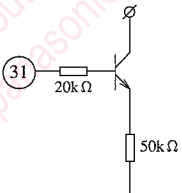
Pin No.	Waveform · Voltage	Equivalent circuit	Pin No.	Waveform · Voltage	Equivalent circuit
19	 DC2.4V		25		
20	 DC2.4V		28 29	5V for playback, and 0V for recording	
22 24 26	 DC3.2V		30	5V for playback, and 0V for recording	
23			31		

ICs for VCR

Note) The above values are typical ones (at $V_{CC}=5.0V$) and may depend on the operating condition and individual IC.

Request for your special attention and precautions in using the technical information and semiconductors described in this book

- (1) If any of the products or technical information described in this book is to be exported or provided to non-residents, the laws and regulations of the exporting country, especially, those with regard to security export control, must be observed.
- (2) The technical information described in this book is intended only to show the main characteristics and application circuit examples of the products. No license is granted in and to any intellectual property right or other right owned by Panasonic Corporation or any other company. Therefore, no responsibility is assumed by our company as to the infringement upon any such right owned by any other company which may arise as a result of the use of technical information described in this book.
- (3) The products described in this book are intended to be used for standard applications or general electronic equipment (such as office equipment, communications equipment, measuring instruments and household appliances).
Consult our sales staff in advance for information on the following applications:
 - Special applications (such as for airplanes, aerospace, automobiles, traffic control equipment, combustion equipment, life support systems and safety devices) in which exceptional quality and reliability are required, or if the failure or malfunction of the products may directly jeopardize life or harm the human body.
 - Any applications other than the standard applications intended.
- (4) The products and product specifications described in this book are subject to change without notice for modification and/or improvement. At the final stage of your design, purchasing, or use of the products, therefore, ask for the most up-to-date Product Standards in advance to make sure that the latest specifications satisfy your requirements.
- (5) When designing your equipment, comply with the range of absolute maximum rating and the guaranteed operating conditions (operating power supply voltage and operating environment etc.). Especially, please be careful not to exceed the range of absolute maximum rating on the transient state, such as power-on, power-off and mode-switching. Otherwise, we will not be liable for any defect which may arise later in your equipment.
 - Even when the products are used within the guaranteed values, take into the consideration of incidence of break down and failure mode, possible to occur to semiconductor products. Measures on the systems such as redundant design, arresting the spread of fire or preventing glitch are recommended in order to prevent physical injury, fire, social damages, for example, by using the products.
- (6) Comply with the instructions for use in order to prevent breakdown and characteristics change due to external factors (ESD, EOS, thermal stress and mechanical stress) at the time of handling, mounting or at customer's process. When using products for which damp-proof packing is required, satisfy the conditions, such as shelf life and the elapsed time since first opening the packages.
- (7) This book may be not reprinted or reproduced whether wholly or partially, without the prior written permission of our company.



LittleDiode supplies new, hard to find or obsolete electronic components and semiconductors all over the world.

With over two million different components listed you are sure to find the part you need.

Feel free to visit us today at our online store:

LittleDiode.com

Looking forward to providing you with the best possible service.