

HOW TO DRIVE DC MOTORS WITH SMART POWER ICs

by Herbert Sax

There are many ways to control DC motors. Open-loop current control acts directly on torque and thus protects the electronics, the motor and the load. Open-loop variable voltage control makes sense if the motor and electronics are not overloaded when the motor stalls. Open-loop variable voltage control with a current limiting circuit constitutes the simplest way of varying speed. However, a closed-loop system is needed if precision is called for in selecting speeds.

No other motor combines as many positive characteristics as the direct current design: high efficiency, ease of control & driving, compactness without sacrificing performance and much more. And DC motors can be controlled in many ways -- open loop current control, variable voltage control or closed-loop speed control -- providing great flexibility in operational characteristics.

Before we turn to a detailed discussion of the various methods of control, it is worthwhile recalling a few basics.

DC MOTOR BASICS

Generally speaking, the electric equivalent circuit of a motor (figure 1) consists of three components: EMF, L and R_M .

Figure 1: Electrical equivalent circuit of a DC motor, consisting of EMF, the winding inductance L and the winding resistance R_M .

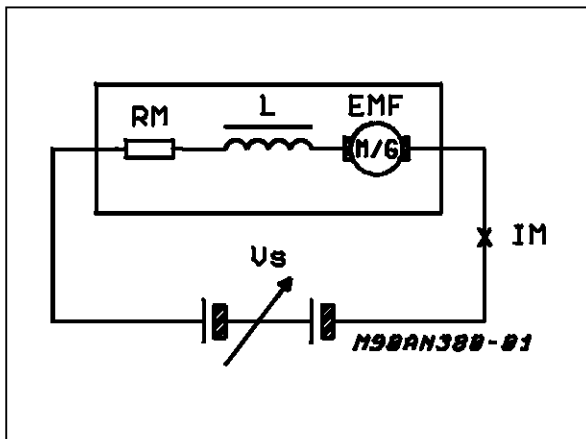

The EMF is the motor terminal voltage, though the motor is always a generator, too. It is of no significance whether the unit operates as a motor

or a generator as far as the terminal voltage is concerned. The EMF is strictly proportional to the speed and has an internal resistance of zero. Its polarity represents the direction of motion, independent of the motor voltage applied.

The winding inductance, L, is the inevitable result of the mechanical design of the armature. Since it hinders the reversal of current flow in the armature, to the detriment of torque as speed increases, the winding inductance is an interference factor for the motor. It also obstructs rapid access to the generator voltage (EMF).

Motors of coreless, bell armature or pancake design are considerably less susceptible to winding inductance. The smaller mass of these motors improves their dynamic performance to a significant extent. On the positive side, the winding inductance can be used to store current in pulse-width modulation (PWM) drive systems.

The winding resistance, R_M , is purely an interference variable because losses that reduce the degree of efficiency increase as the load torque on the motor shaft increases, the latter being proportional to the current I_M . It is also due to the winding resistance that the speed of the motor drops as load increases while the terminal voltage V_S remains constant.

Some of the mathematical relationships are shown below in simplified form:

$$EMF = V_S - (I_M \cdot R_M)$$

$$\text{Motor current } I_M = (V_S - EMF) / R_M$$

$$\text{Efficiency} = \frac{EMF \cdot I_M}{V_S \cdot I_M} = \frac{P_{OUT}}{P_{IN}}$$

The drive torque at the motor shaft is proportional to the motor current I_M . Figure 2 shows the relationships graphed in a form commonly used for DC motors. It is because of bearing and brush friction that the efficiency tends towards zero at low load torques.

APPLICATION NOTE

Figure 2: Relationship between speed, efficiency and motor current of a DC motor.

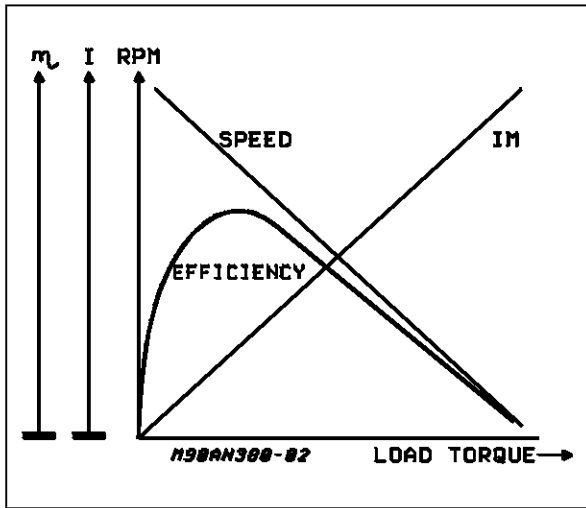

These basics show that essentially there are only two parameters governing how an electrical change can be made to act on the motor shaft:

- a) with the current to vary the torque
- b) with the mapping of the EMF on the speed

On account of the winding resistance R_M , open loop variable voltage control exercises no more than an indirect effect on torque and speed and can therefore be used only for simple functions (speed variation).

A number of sample applications using smart

power ICs and illustrating open-loop variable voltage or current control and closed loop speed control are discussed here. All of these circuits permit the motor to run in both directions. The modifications needed for unidirectional operation are slight and generally involve a simplification of the design.

OPEN-LOOP VARIABLE VOLTAGE CONTROL

In technical terms variable voltage control is the simplest to implement. Its main scope of application is in simple transport or drive functions where exact speed control is not essential. Applications of this kind are found, for example, in the automobile industry for driving pumps, fans, wipers and power window lifts.

The circuit shown in figure 3 is an example of a variable speed motor with digital direction control. The motor voltage can be controlled via an analog input. If the polarity of the control signal is the variable that determines the motor's direction of rotation -- as is usually the case in servo systems, for example -- the design shown in figure 4 can be used.

One of the operational amplifiers is responsible for the V_M/V_{IN} voltage and the other has a gain of 1, so that the voltage losses $V_S - V_M$ are divided evenly between the two parts of the bridge.

Equivalents to the circuits in figures 3 and 4 are shown in figure 5 and figure 6; these latter circuits, however, are switchmode and their efficiency is thus improved to a considerable extent.

Figure 3: Circuit for driving a variable-speed motor. Where the enable function is needed, the type L6242 can be used.

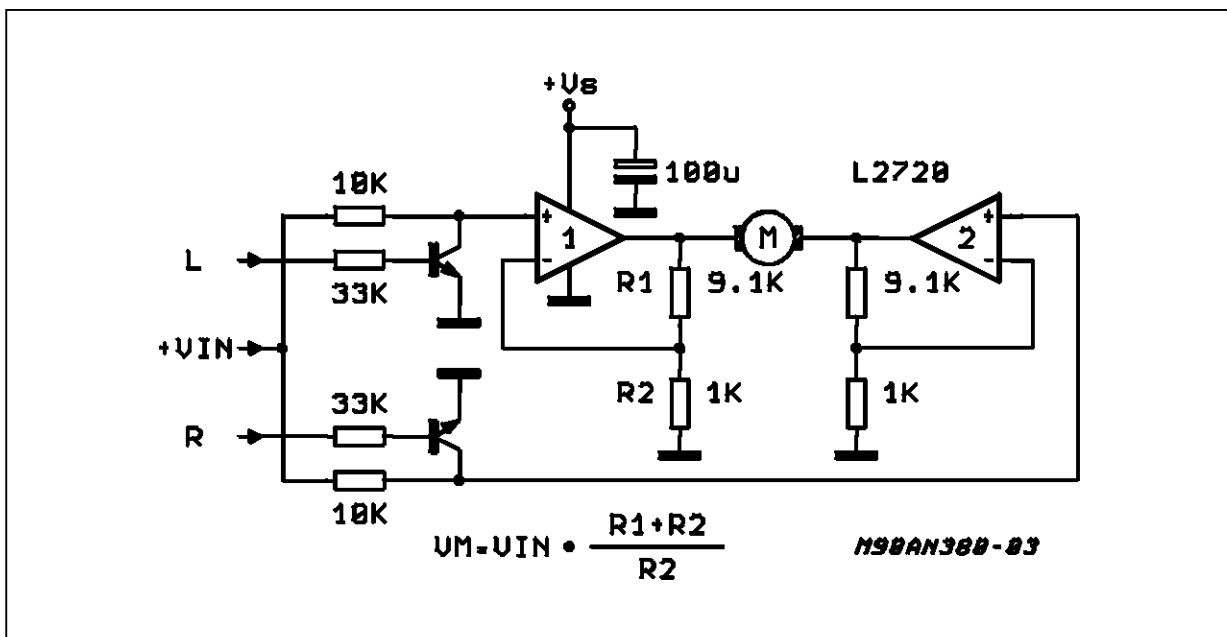

Figure 4: A typical circuit for driving servo system.

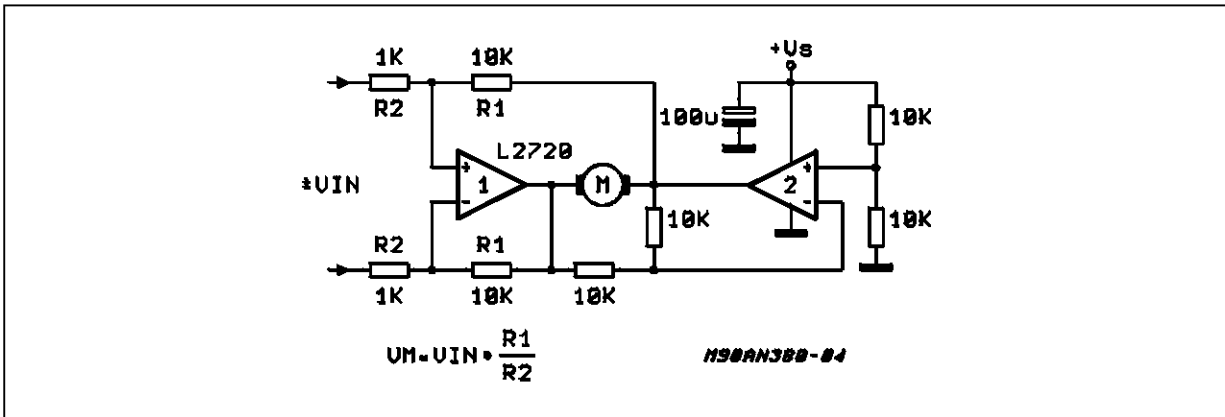

Figure 5: Equivalent circuit to that in Figure 3, but using PWM.

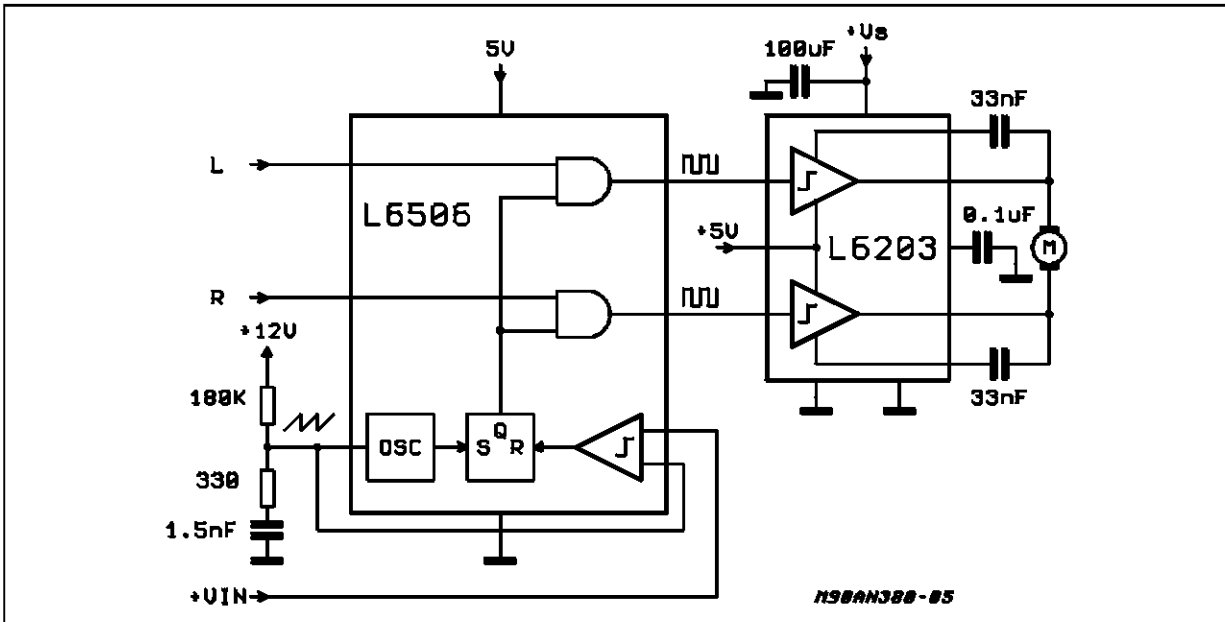
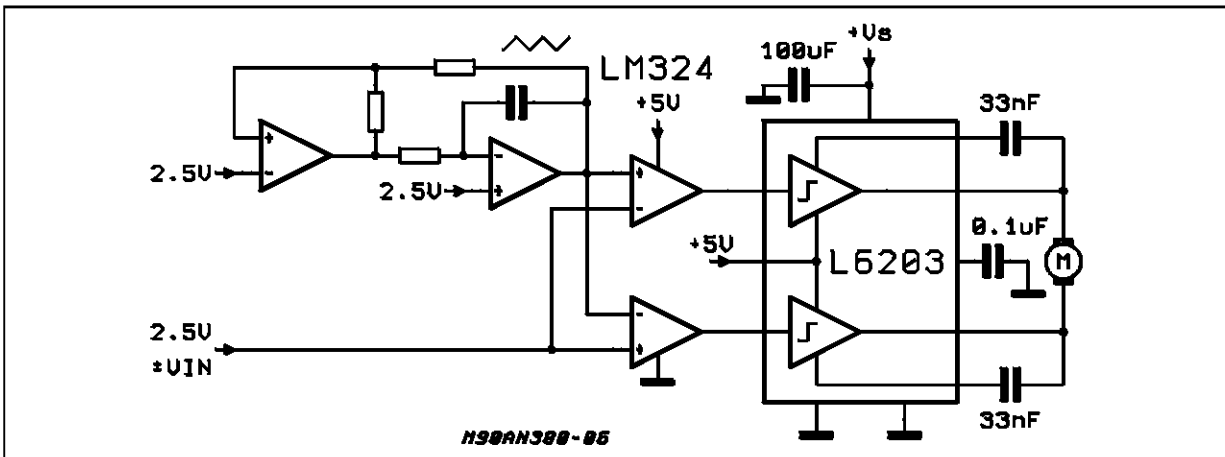

Figure 6: Equivalent circuit to that in Figure 4, but using PWM.



APPLICATION NOTE

OPEN-LOOP CURRENT CONTROL

Open-loop control is called for whenever a motor has to supply a constant or variable torque. Applications include the head motors in tape recorders or the motors used to tension threads when textile fibers are wound onto spools. The speed of the motor at any given time is of no significance. In applications of this nature the motor shaft will often rotate in the direction opposite to that determined by the current.

Two conditions are particularly important in a current controlled application. The circuit will not operate unless $V_{Mmax} \geq EMF + (I_M R_M)$, if the motor shaft is running in the same direction as the drive. The equation applicable to a counter rotating motor shaft is:

$$-V_{Mmax} - EMF \leq I_M R_M$$

Open-loop current control is often used in con-

junction with open-loop variable voltage control or closed loop speed control. Such an arrangement would be designed to:

- ◆ limit torque to protect the load and the motor
- ◆ protect the power ICs against overload
- ◆ obtain acceleration and deceleration characteristics independent of speed.

Figure 7 shows the simplest form of open-loop current control with a positive & negative supply. Transferring the circuit to a bridge eliminates the ground at one end of the shunt R_s and a way of differentially sampling the sense resistor voltage must be found. One solution is shown in figure 8. As in figure 4, the second half of the bridge operates as a voltage inverter.

Figure 7: Current control circuit with bipolar voltage supply in its simplest form.

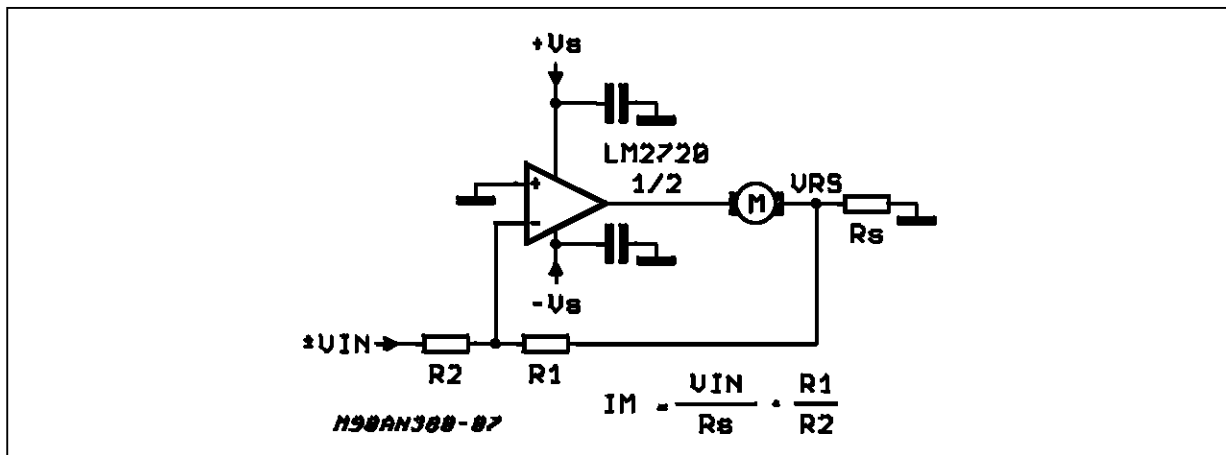
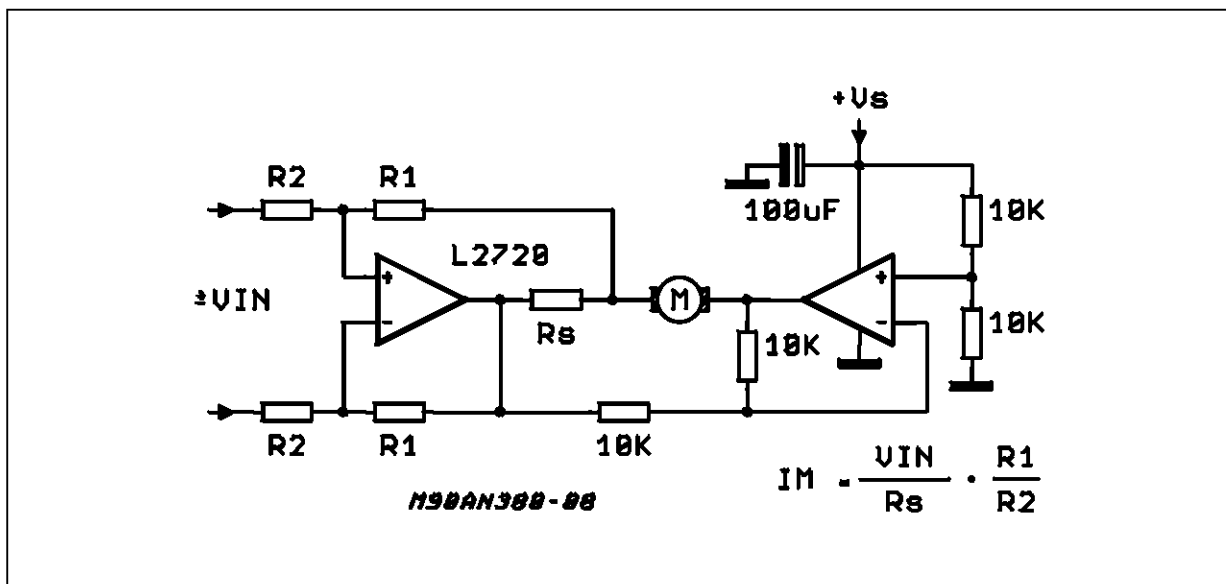

Figure 8: This circuit permits differentiated sampling of the voltage at the sense resistor.



When the principle behind the circuit shown in figure 8 is transferred to a switchmode circuit (figure 9), a considerable degree of complexity is called for to reduce power loss. For this reason the circuit is shown in slightly simplified form.

Operational amplifier 1 reconstructs the current proportional voltage V_{RS} to ground as shown in figure 7. Two sense resistors are needed, as otherwise it would not be possible to detect the direction of the current in the bridge.

Operating as a PI controller and converting the error signal in a PWM via comparator 3, OP2 compares the reference and feedback values. One major advantage of a circuit such as that shown in figure 9 is its high transfer linearity maintained even in the vicinity of the zero current crossing. Open-loop current control also functions

with a generator, the motor returning its own kinetic energy and that of the load to the supply voltage in a controlled manner. Braking is a case in point, and for this reason circuits of this design are usually found in servo positioning drives that demand precise current control over a wide operating range.

CLOSED-LOOP SPEED CONTROL

Many circuits, often of completely different design, have been developed for closed-loop speed control. The most suitable system has to be chosen on the basis of the requirements that a drive concept has to meet. These requirements also determine how the speed will be sensed and processed.

Figure 9: Operating principle of the circuit of figure 8 transferred to a PWM arrangement.

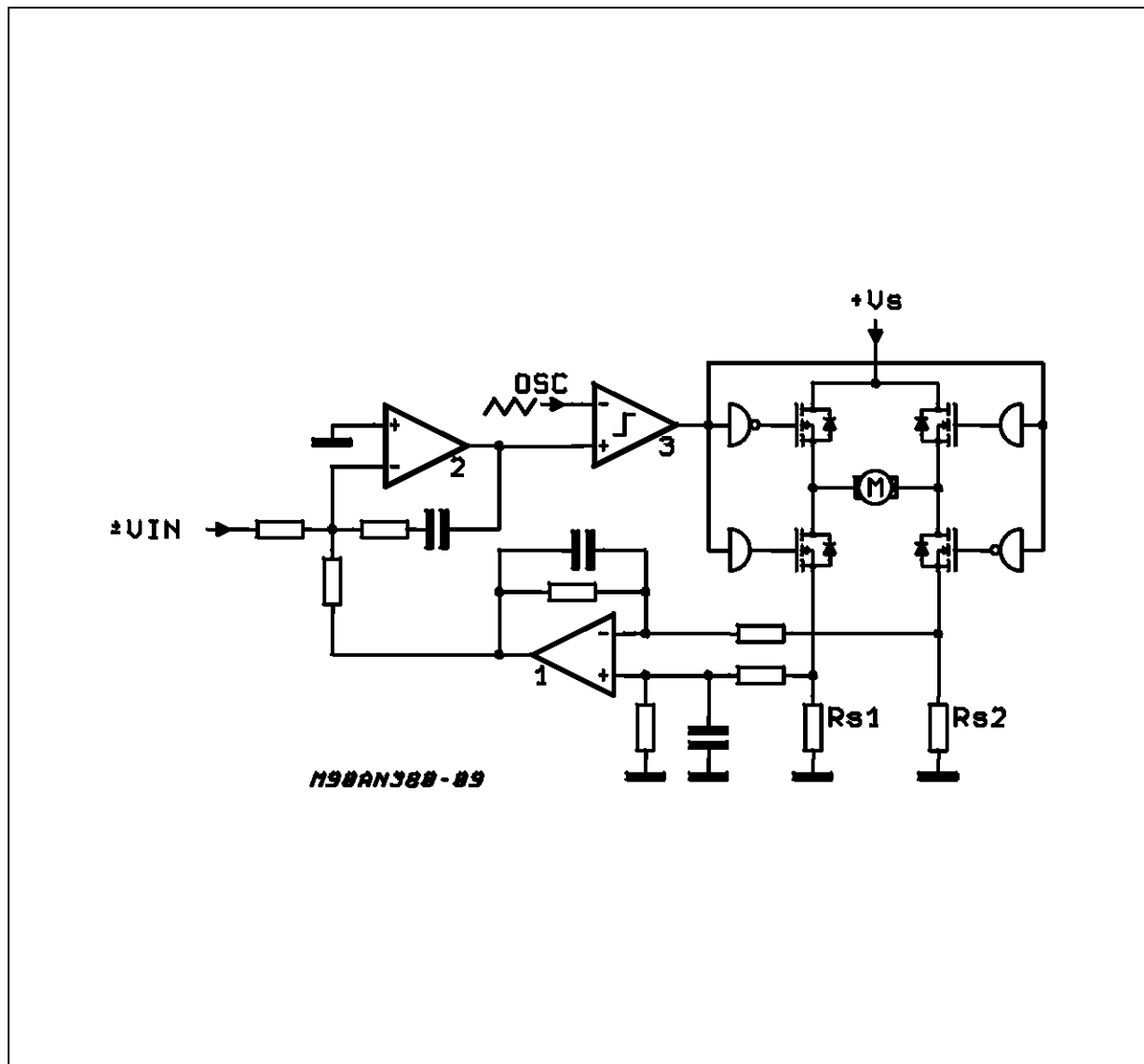

APPLICATION NOTE

The table provides an overview of the most common principles of sensing and processing and

their influence on control characteristics and system costs.

CHARACTERISTICS		PRINCIPLE OF SPEED SENSING					SIGNAL PROCESSING			AC REFERENCE	
		DC Tacho	V-I Control	EMF Sense	AC Tacho	Commutation Sense	P Control	PI Control	PID Control	PLL Control	Digital Sensor
CONTROL ACCURACY	HIGH				•	•				•	•
	MEDIUM	•		•				•	•		
	LOW		•				•				
EXTENDED CONTROL RANGE POSSIBLE		•		•			•				
CONTROL REACTION	FAST	•	•	•			•		•		•
	SLOW				•	•		•			
GOOD CONTROL CHARACTERISTICS AT LOW SPEEDS		•		•			•		•		
SUITABLE FOR SERVO DRIVES		•					•	•	•		•
SYSTEM COST	HIGH	•								•	•
	MEDIUM			•	•				•		
	LOW		•			•	•	•			

CLOSED-LOOP CONTROL PROCESSES

DC Tachogenerator

Since a control circuit with a DC tachogenerator yields a direct voltage that is proportional to speed, the circuit itself is less complex than all other designs. Nonetheless, high precision -- a constant voltage with low ripple -- signifies high cost. On the other hand, the actual electronic control circuit is simplicity itself, as figure 10 shows. The bridge extension for a simple supply voltage

is identical to that shown in figure 8.

A closed loop current control system providing braking and acceleration independent of the supply voltage and the internal motor resistance is easy to superimpose on the circuit (figure 11).

Similarly little difficulty is involved in modifying the circuit in figure 10 to yield a switched bridge, because the process entails no more than converting the control error signal into a PWM output (figure 12).

Figure 10: Control with DC tachogenerator: a direct speed proportional DC voltage is generated.

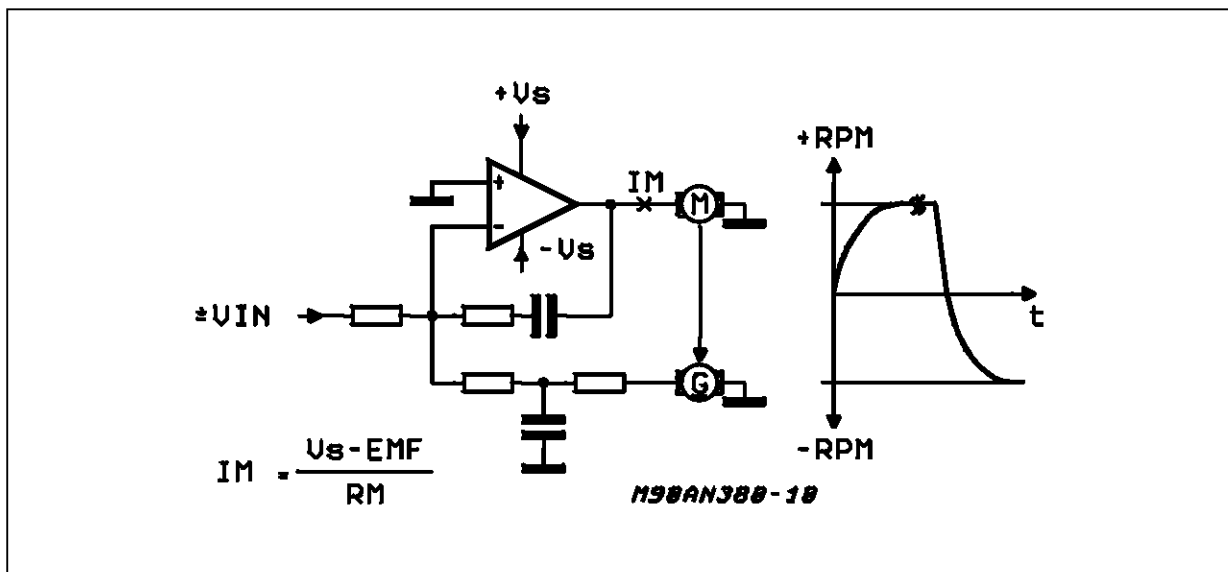

Figure 11: In this circuit, acceleration and braking behavior is independent of the supply voltage and the motor's internal resistance.

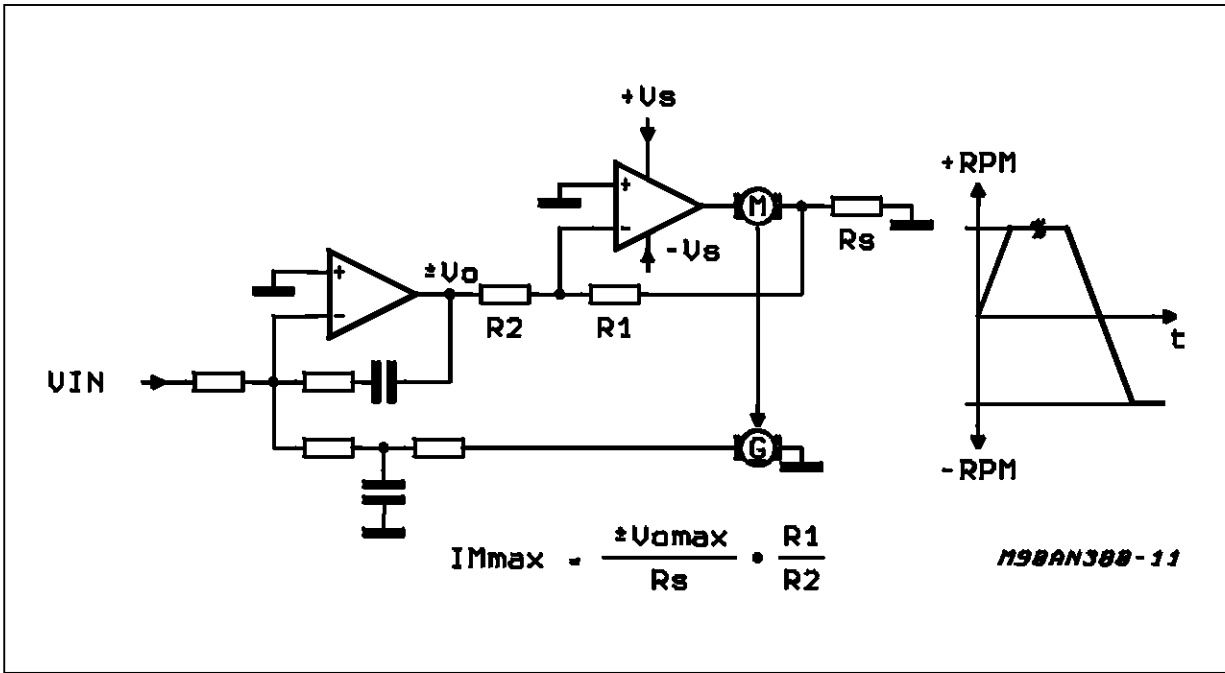
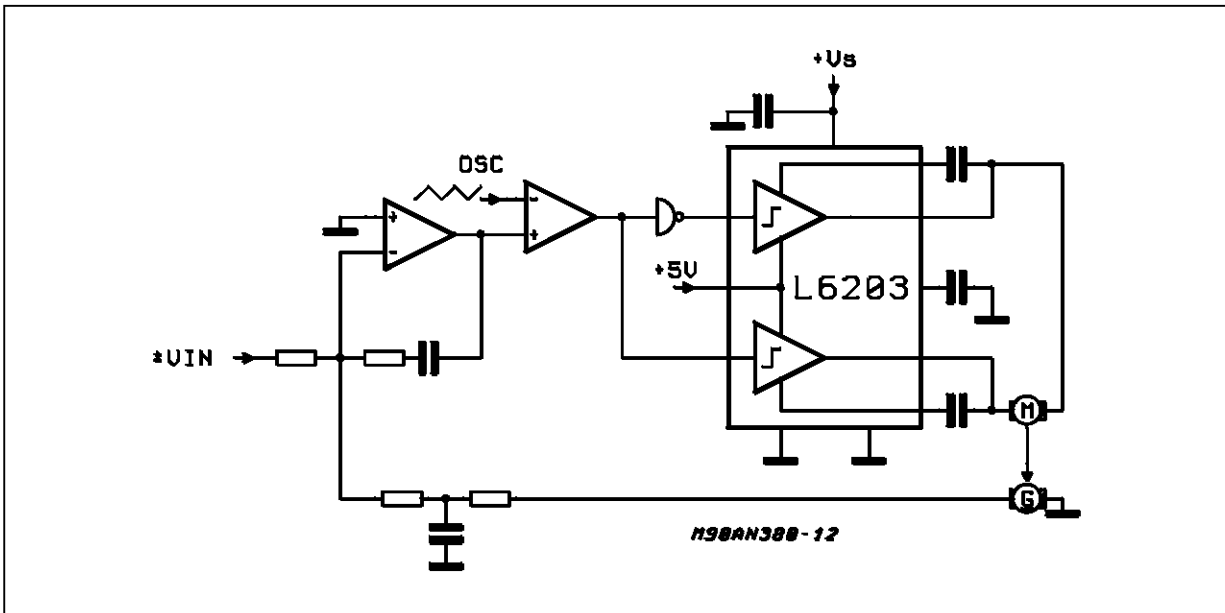

Figure 12: PWM conversion of the control error signal.



V-I Control (Internal Resistance Compensation)

V-I control is based in the principle that the voltage drop at the motor internal resistance I_M , that increases with load torque can be compensated by increasing the motor voltage V_M (figure 13). However, compensation is less than complete because the winding resistance R_M is heavily dependent on the temperature, and brush resis-

tance modulation makes itself felt as an additional interference variable.

In practice this means that the voltage drop is slightly under compensated and positive feedback is reduced even further as frequencies get higher. The control action result improves with the ratio of EMF to $I_M.R_M$. A sample circuit in which the effect of the positive feedback loop can clearly be seen is shown in figure 14.

APPLICATION NOTE

The desired speed is set with the aid of R1 and R2. The relationship is expressed as:

$$EMF = V_{IN} \cdot R1/R2$$

The value selected for R_S is one tenth of R_M and V_{RS} is amplified by a factor of 10 in OP2 (R5 = R4/10).

The output voltage of OP2 is then identical with the voltage drop at R_M. When R1 = R3, the inter-

nal resistance is compensated by 90%. Residual control instabilities can be cancelled out by C1.

The circuit can also be extended to a bridge, although this entails relocating resistor R_S (figure 15). It is surprising that the V-I controller circuitry is again simplified to a considerable extent if amplification is not needed. The V-I control concept can be adapted for a PWM motor control system; the functional layout is rather complex, however, as figure 16 shows. Even so, it is worthwhile in many instances because DC tachogenerators are expensive.

Figure 13: The principle of V-I control.

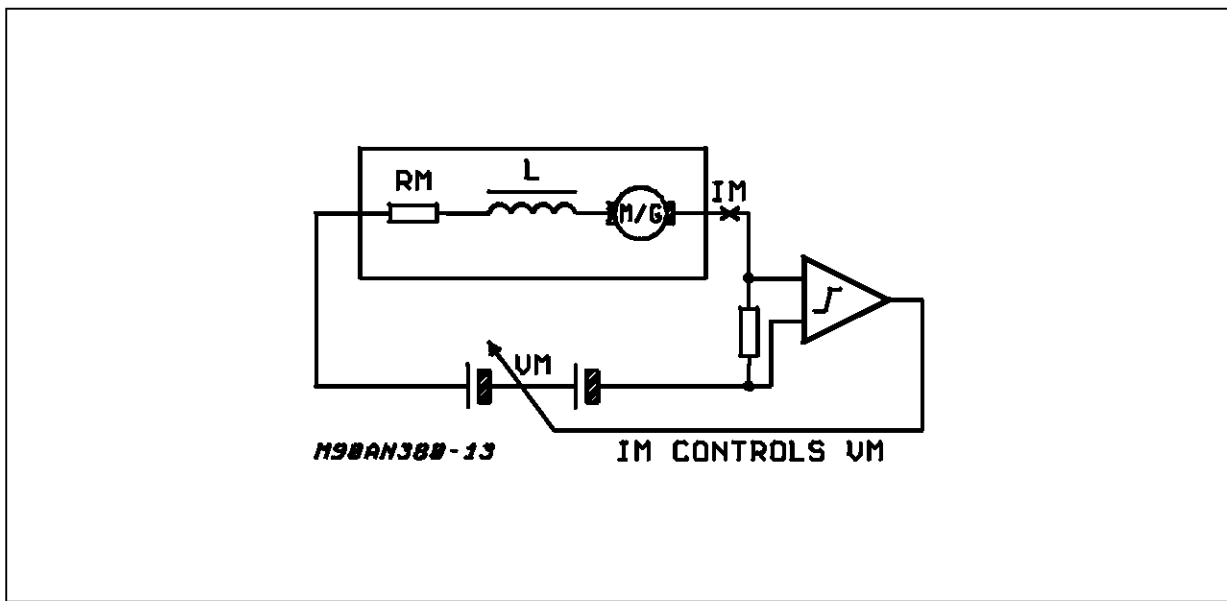

Figure 14: Example circuit in which the positive feedback loop can clearly be seen.

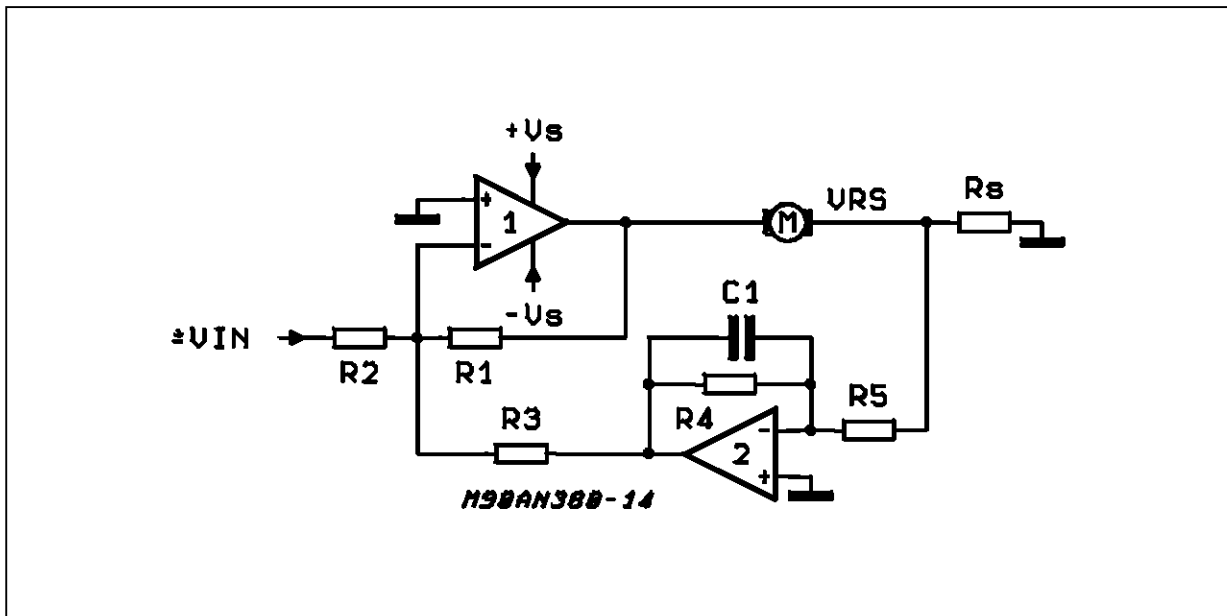

Figure 15: Circuit as in figure 14, expanded to include a bridge.

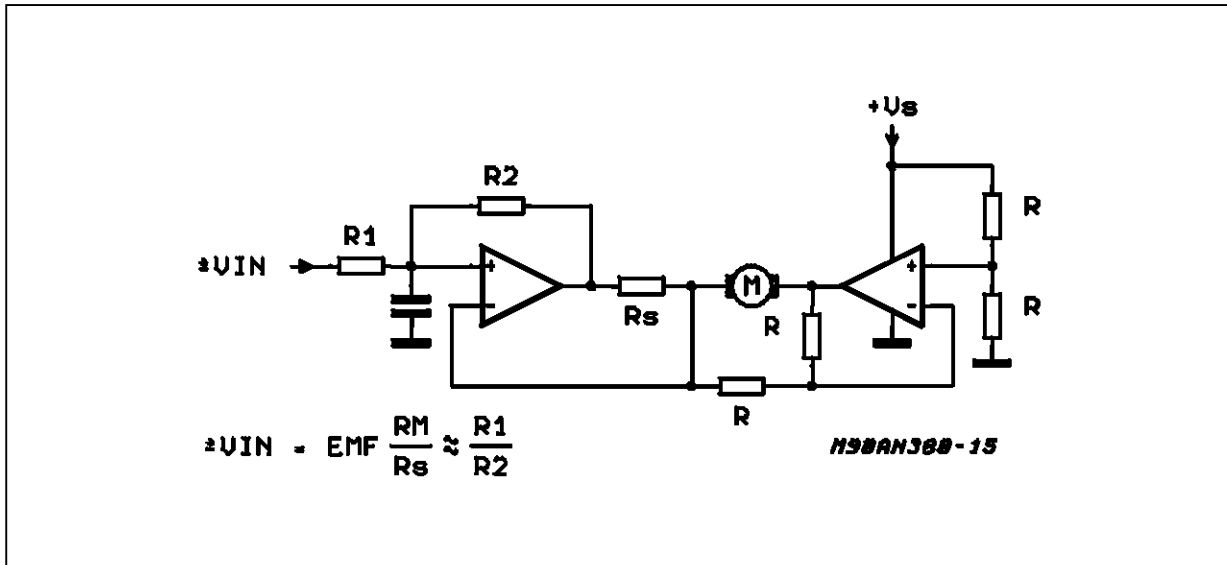
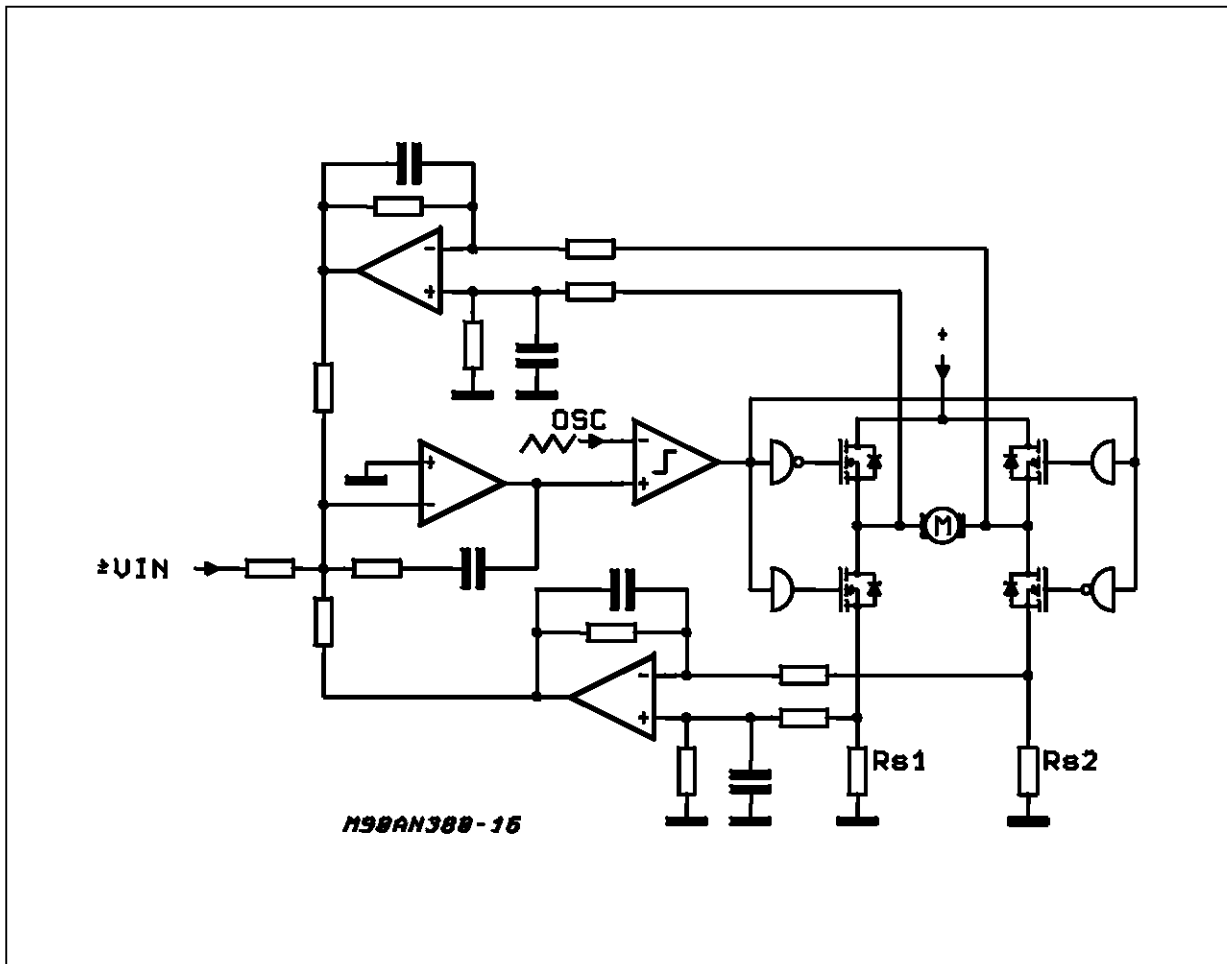

Figure 16: The principle of V-I control transferred to a PWM motor circuit: complexity is increased significantly.



APPLICATION NOTE

EMF Sensing

The EMF can also be sensed directly, rather than be simulated as in the V-I control setup, when the current I_M is zero ($EMF = V_M - I_M \cdot R_M$). To achieve this the motor current must be switched off as quickly as possible. Motor inductance represents an obstacle since the energy it stores must first be dissipated before an EMF measurement can be made at the motor terminals. This is the reason why only coreless motors of bell armature or pancake design are suitable. Figure 17 is a block diagram showing how the EMF can be sensed.

In the major partial time t_1 the motor carries current. This is followed by a time window t_2 in which the motor is de-energized and the motor inductance discharges. There then follows a short sampling phase t_3 in which the EMF is sensed and

stored in a capacitor until the next sampling phase. The number of cycling cycles per second depends on the dynamic behavior of the load torque. The interval between any two EMF measurements should be of a duration such that the kinetic energy of the drive system bridges a load change without a significant speed drop. Figure 18 illustrates a layout using a current-controlled output stage that has a high impedance output when the input is open.

The circuit for sensing EMF is particularly well suited to switchmode motor control schemes. The monolithic switching output stages available today already have an enable input for releasing the motor, but the concept will usually accommodate this option even if discrete output stages are used. An example circuit is shown in simplified form in figure 19.

Figure 17: Principle by which the EMF can be sensed.

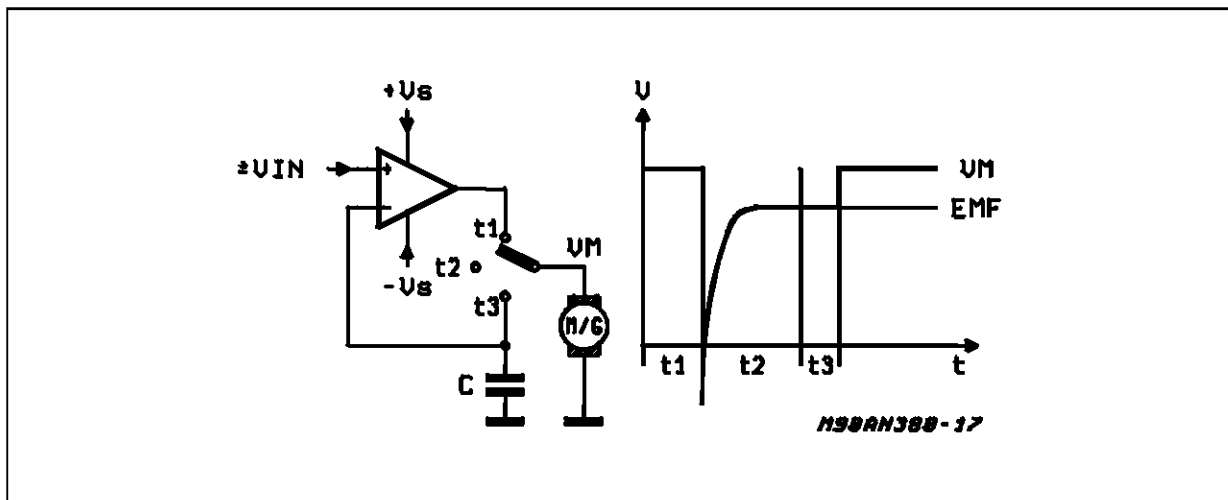

Figure 18: Driver circuit with current controlled output stage with high impedance output when input is open.

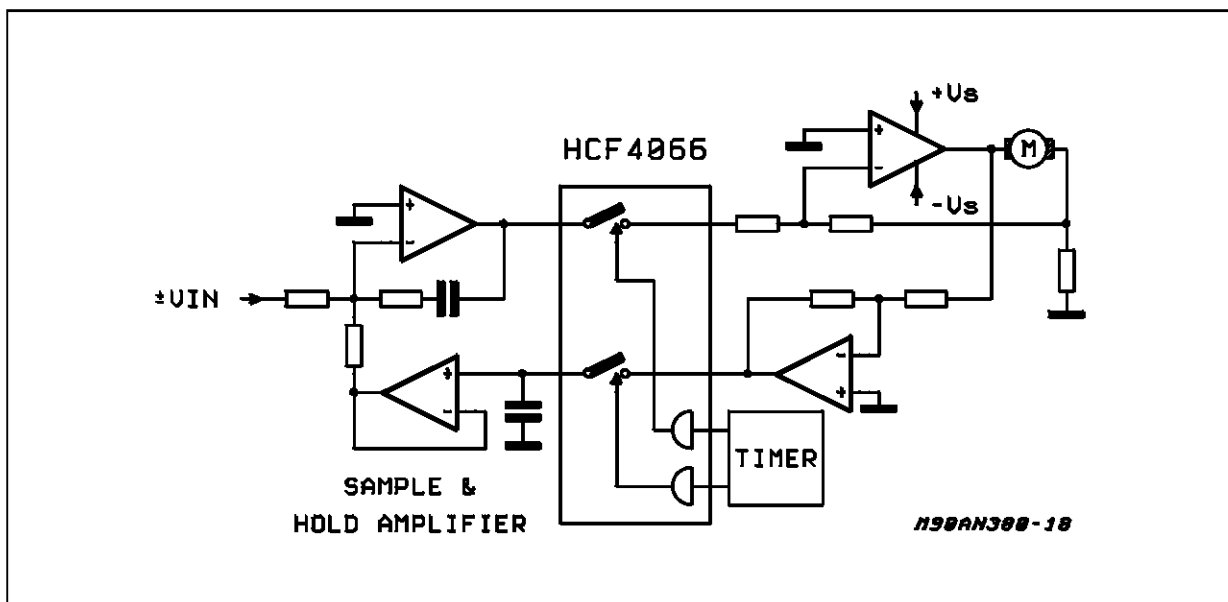
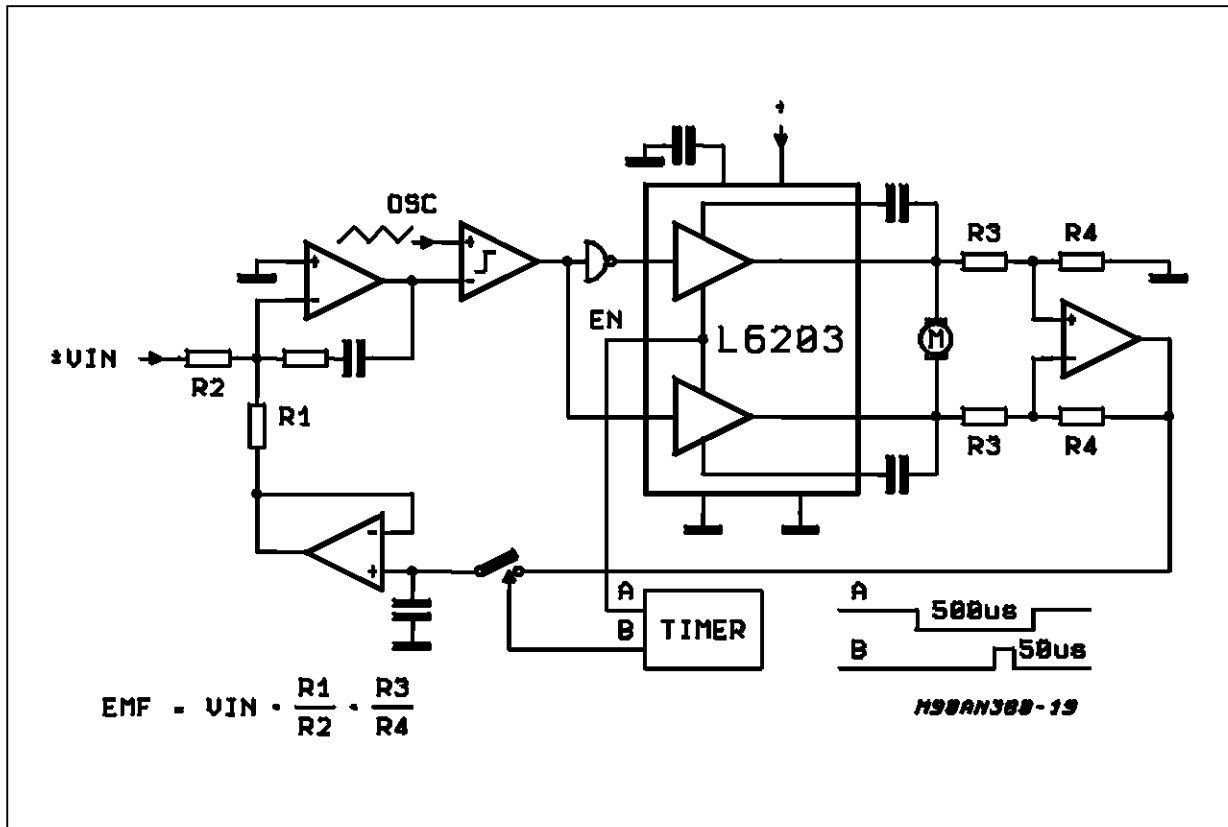

Figure 19: Circuit as in figure 18, but with PWM output stage.



AC Tachogenerator

Economic and with a signal that is easy to process, the AC tachogenerator is the most frequently used means of sensing the speed of a DC motor. Problems arise, however, when the tachogenerator frequency is low, due either to a low speed or a lack of poles on the generator. However, multiple pole tachogenerators are expensive regardless of whether they are magnetic or optical. Most circuits convert the speed proportional tacho frequency back into a DC signal in an f/V converter (Fig. 20).

However, some circuits make use of the proportional relationship between speed and AC voltage amplitude when the tachogenerator is inductive (figure 21). Accuracy is wanting to a certain extent in this arrangement.

Since the output signal of an AC tachogenerator contains no information concerning the direction of rotation, the control loop functions in only one quadrant. For the same reason it is common practice to control the reference in a single quadrant. A separate digital signal determines the direction of rotation. Figure 22 shows a typical

Figure 20: The tachogenerator frequency can be converted back into a DC signal in an f/V converter.

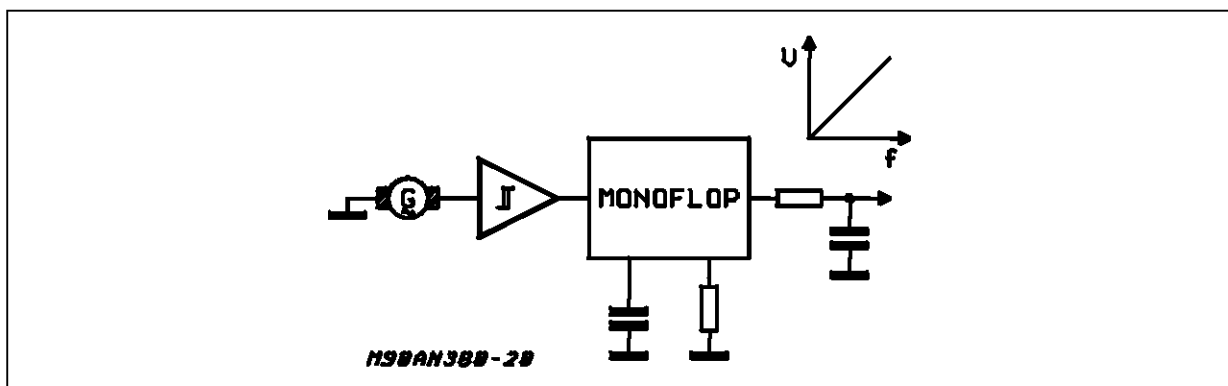

APPLICATION NOTE

PWM circuit.

Comparator 1 converts the sinusoidal tachogenerator signal into a squarewave voltage that triggers the monostable. The ON time is constant, which means that the DC average increases proportionally as the tachogenerator frequency increases. The error amplifier OP1 also functions as an integrator (C1) and compares the DC reference with the DC average of the monostable output. A DC signal superimposed by a triangular wave AC voltage component can be detected at the output of OP1.

An analog power operational amplifier can also be used instead of the switchmode output stage. In an arrangement like this, the output of the error amplifier OP1 drives the V_{IN} input of the output stage as shown in figure 3.

Figure 21: Alternatively, the proportionality between speed and AC amplitude can be used if the tachogenerator is inductive.

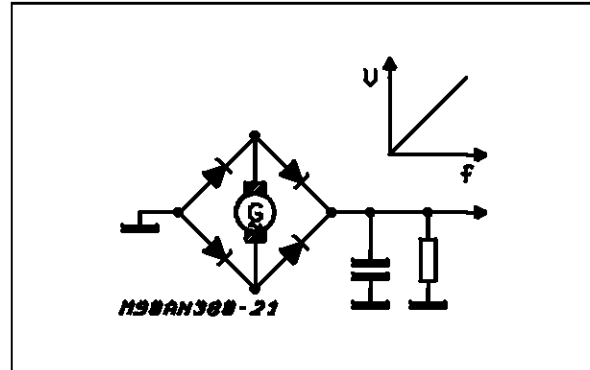
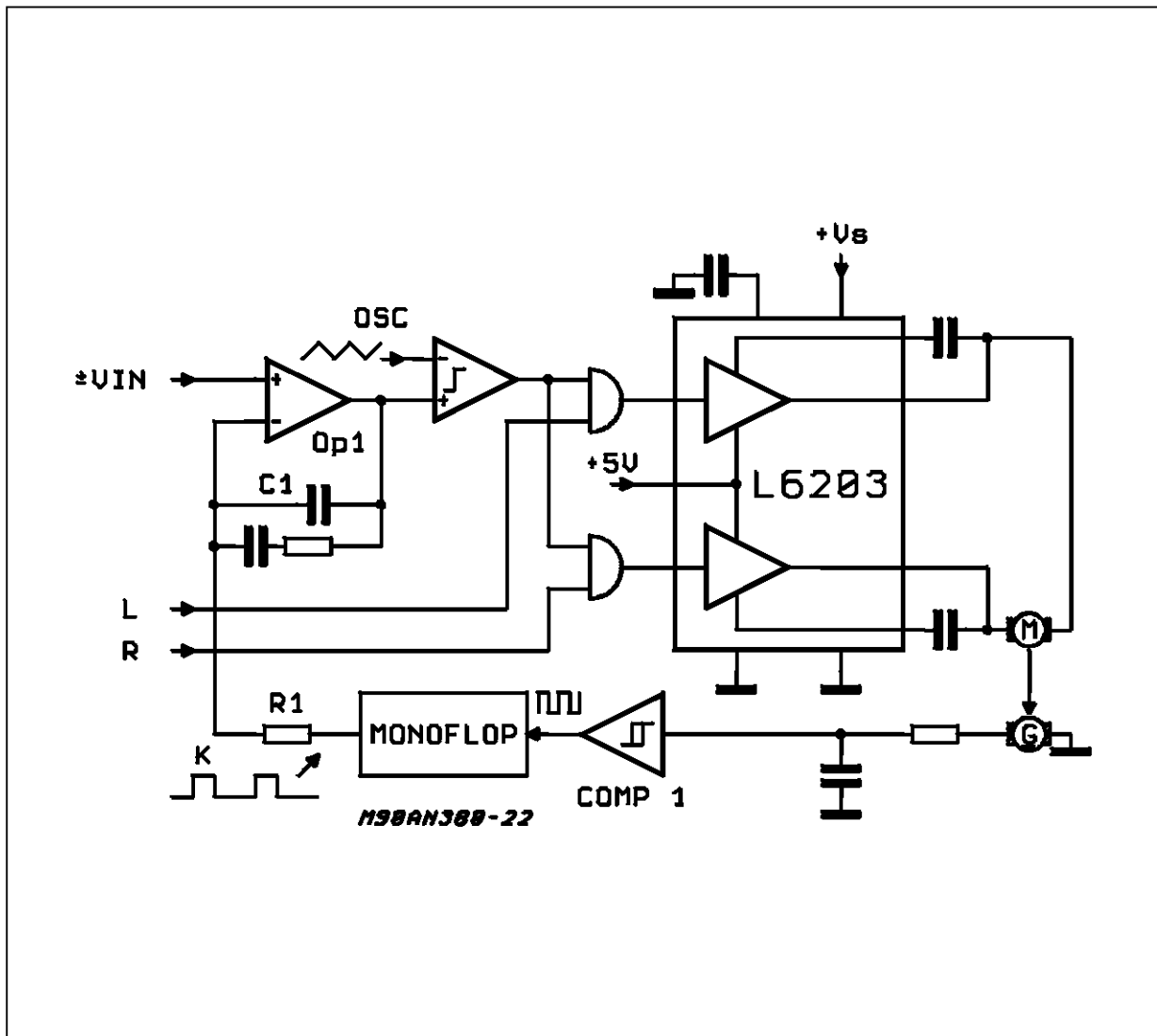

Figure 22: In this PWM circuit the comparator 1 converts the sinusoidal tachogenerator signal into a squarewave.



COMMUTATION Sensing

Commutation sensing is a process that exploits the inherent ripple of the EMF of the motor current as an AC tachogenerator. However, only motors with few poles yield an adequate signal-to-noise margin. Three-pole motors with an AC component equal to approx 30% of the DC value are most suitable (figure 23).

The rapid current reversal is differentiated and used as an equivalent tachogenerator signal (figure 24). The rest of the circuit follows the pattern shown in figure 22, although only one output stage of the type shown in figure 3 is used. A switchmode output stage would interfere with the ripple sensing so is not recommended. One drawback of commutation sensing is the exceptionally low tachometer frequency. A three pole motor, for

example, produces a frequency of 200Hz at a speed of 2000 rpm.

Since the AC component of the OP1 error amplifier output signal (figure 22) should not be more than 10% of the DC component at rated speed and nominal load torque, the integrator time constant C1R1 is very large. Control response is sluggish and no longer suitable for rapid load changes.

Assistance can be obtained by superimposing V-I control which has high-speed response to relieve the tachogenerator control loop and accelerate transient response by a considerable margin. Figure 25 shows a sample circuit for a bridge.

Superimposed V-I control can also be used with a real AC tachogenerator to improve the transient load response.

Figure 23: Principle of commutation sensing.

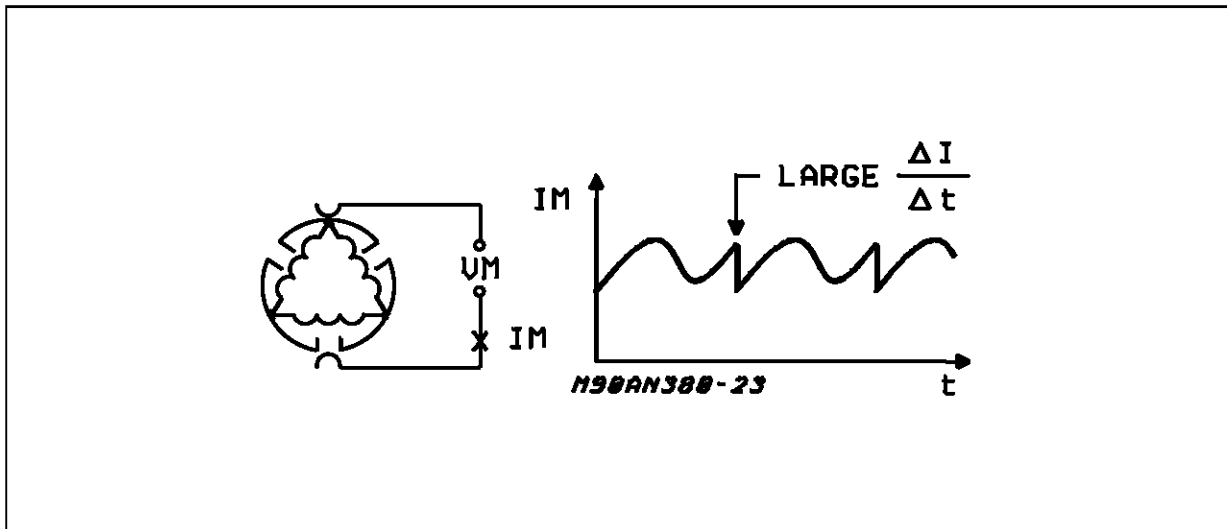
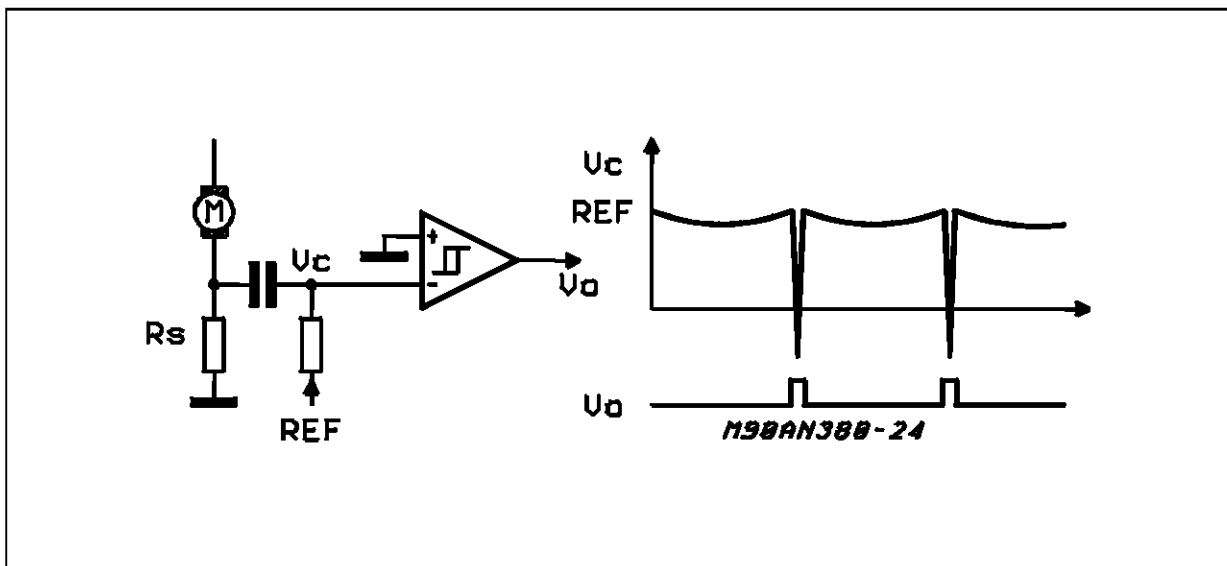
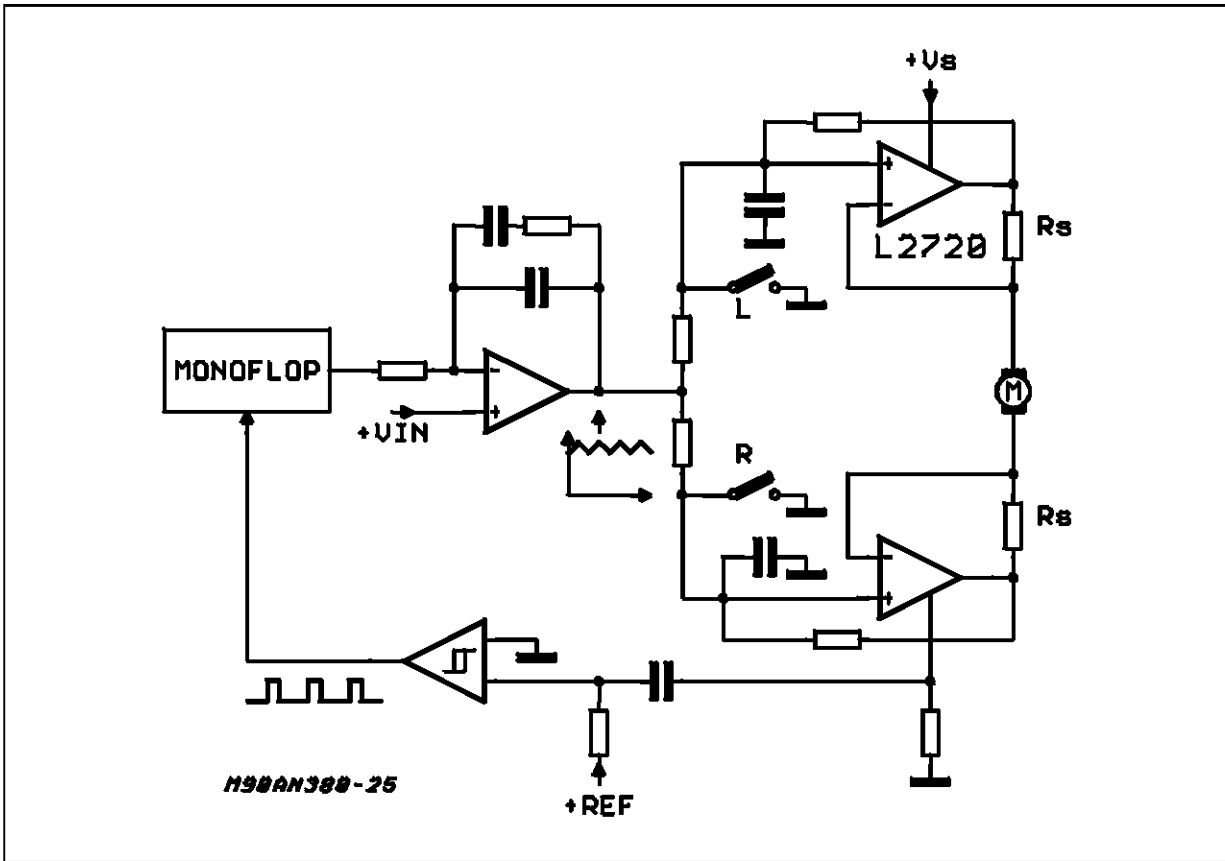

Figure 24: The fastest current reversal is commutated and used as a substitute tachogenerator signal.



APPLICATION NOTE

Figure 25: Example circuit for a bridge.



Processing the Tachogenerator Signal

The control principle (figure 26) applied in proc-

essing the speed feedback and reference signals in a controlled system depends on a number of factors (table page 6).

Figure 26: P, I, PI and PID controllers.

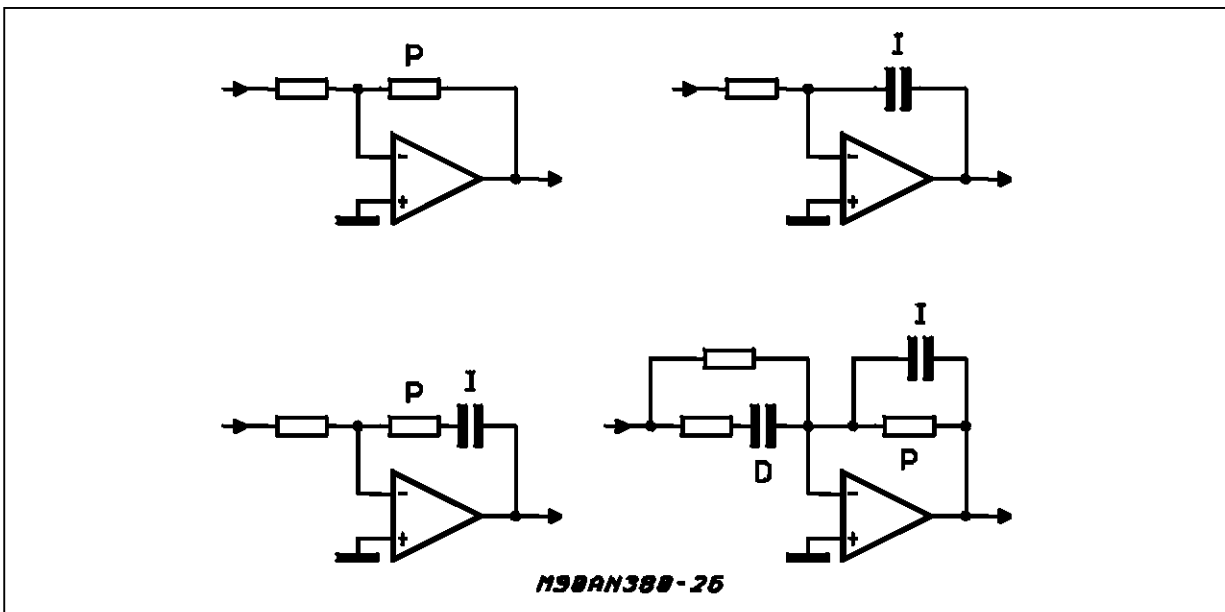

APPLICATION NOTE

The criteria governing the selection of a P controller, an I controller, a PI controller or a PID controller are as follows: stability of the control loop, reaction time, transient response, load behavior, speed range and control factor. For example, if the reference signal is a frequency it would make sense to use an AC tachogenerator as the feedback value sensor and process both signals on a purely digital level. Powerful microcontrollers or digital signal processors are used.

In special cases that demand a control error of zero -- for example, when two drive shafts have to be phase synchronized as well as running at the

same speed -- PLL control is the only option. A system of this nature compares reference and feedback value for phase as well as frequency. In turn, of course, the AC tachogenerator must meet extreme requirements regarding phase stability since any jitter would be interpreted as a control error, producing a spurious response in the system.

PLL speed control systems are used in video recorders, floppy and hard disk drives and in a number of industrial drive systems. Figure 27 shows a typical PLL speed control circuit. The frequency comparator is phase comparator 2 of the HCF4046 CMOS PLL circuit.

Figure 27: Typical PLL circuit for controlling speed.

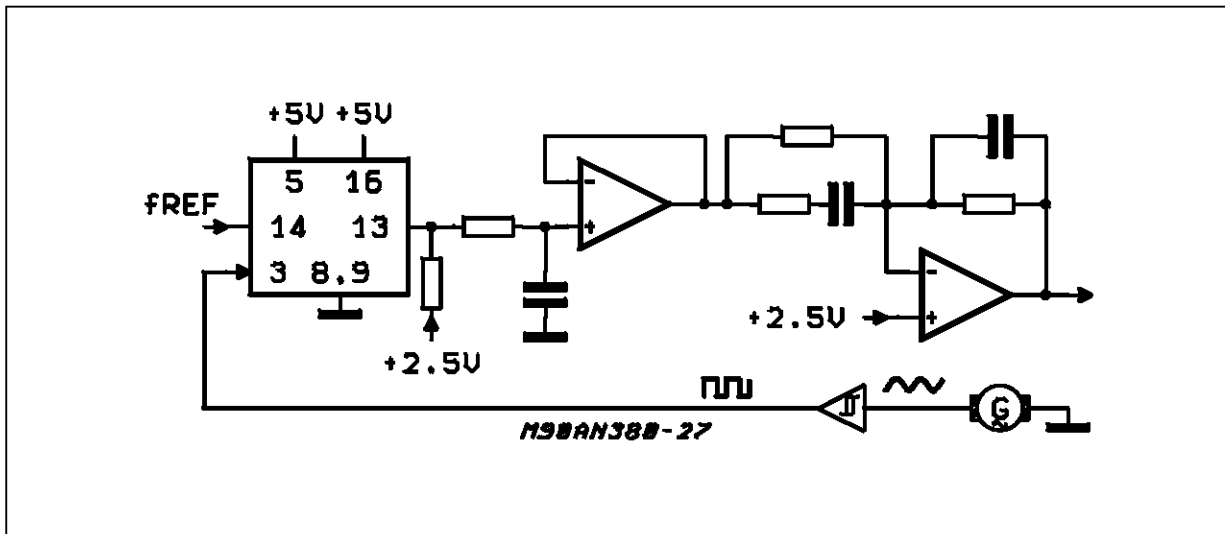

APPLICATION NOTE

Information furnished is believed to be accurate and reliable. However, SGS-THOMSON Microelectronics assumes no responsibility for the consequences of use of such information nor for any infringement of patents or other rights of third parties which may result from its use. No license is granted by implication or otherwise under any patent or patent rights of SGS-THOMSON Microelectronics. Specifications mentioned in this publication are subject to change without notice. This publication supersedes and replaces all information previously supplied. SGS-THOMSON Microelectronics products are not authorized for use as critical components in life support devices or systems without express written approval of SGS-THOMSON Microelectronics.

© 1995 SGS-THOMSON Microelectronics - All Rights Reserved

SGS-THOMSON Microelectronics GROUP OF COMPANIES

Australia - Brazil - France - Germany - Hong Kong - Italy - Japan - Korea - Malaysia - Malta - Morocco - The Netherlands - Singapore - Spain - Sweden - Switzerland - Taiwan - Thailand - United Kingdom - U.S.A.



LittleDiode supplies new, hard to find or obsolete electronic components and semiconductors all over the world.

With over two million different components listed you are sure to find the part you need.

Feel free to visit us today at our online store:

LittleDiode.com

Looking forward to providing you with the best possible service.