

# AN3336SB

## 4-Head VCR Recording/Playback Amplifier IC

### ■ Overview

The AN3336SB is a recording/playback amplifier IC for 4-head VCR. It includes RF-AGC, automatic tracking I/O, and envelope comparing circuit.

### ■ Features

- Playback  $V_{CC} = 5.0V$ , recording  $V_{CC} = 12V$
- Built-in RF-AGC circuit
- Built-in automatic tracking I/O circuit
- Built-in envelope comparing circuit

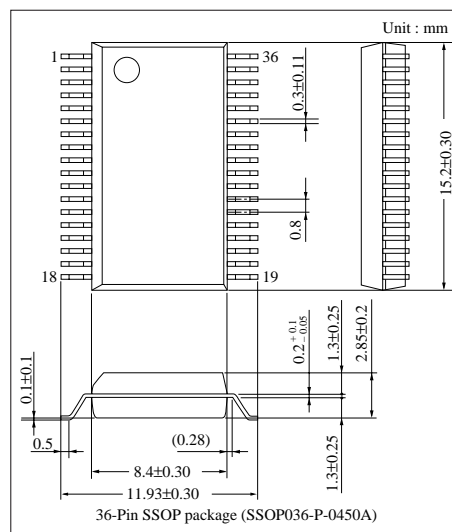

### ■ Pin Descriptions

Pin No.	Pin name	Pin No.	Pin name
1	Head switching	19	Envelope detector capacitor for ch 3 and ch 4
2	Envelope ON/OFF switching	20	Peaking for recording
3	Ch 1 head amp. damping	21	Automatic tracking output
4	Ch 1 head amp. input	22	Automatic tracking detector capacitor
5	Small-signal ground	23	Automatic tracking control
6	Ch 2 head amp. input	24	Automatic tracking $V_{CC}$
7	Ch 2 head amp. damping	25	Rec. Y-input
8	Sub-ground	26	Chroma output
9	Sub-ground	27	Sub-ground
10	Ch 3 head amp. damping	28	Sub-ground
11	Ch 3 head amp. input	29	Sub-ground
12	Small-signal ground	30	Recording C-input
13	Ch 4 head amp. input	31	AGC output
14	Ch 4 head amp. damping	32	AGC detector capacitor
15	Rec. current amp. (LP) output	33	Envelope detector capacitor for ch 1 and ch 2
16	Rec. feedback	34	Head amp. switching
17	Rec. current amp. (SP) output	35	ENV output, recording bias
18	Rec. $V_{CC}$	36	Playback $V_{CC}$

■ Block Diagram

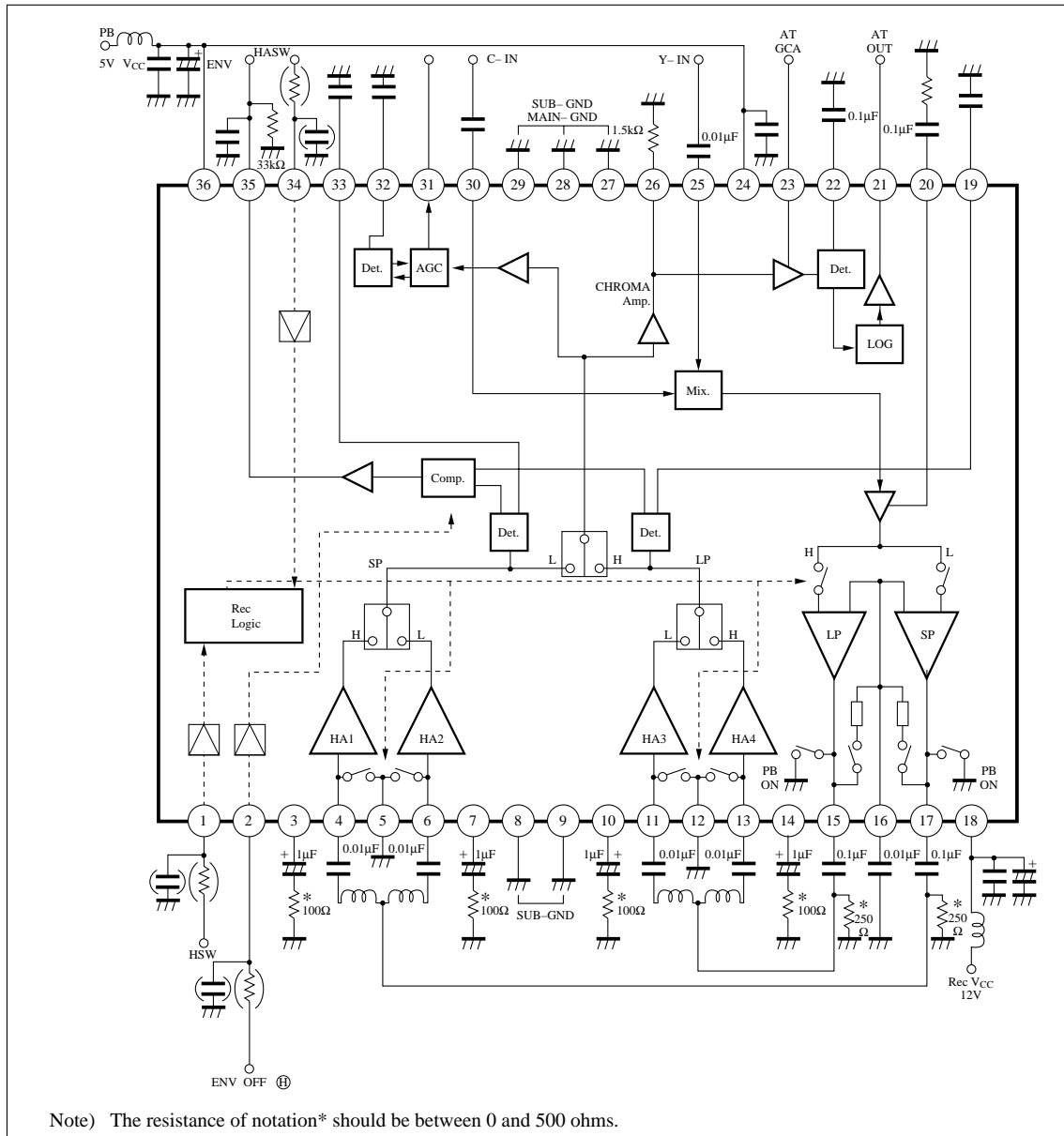

■ Absolute Maximum Ratings

Parameter	Symbol	Rating	Unit
Supply voltage (1)	PB V <sub>CC</sub>	6	V
Supply current (2)	Rec V <sub>CC</sub>	13	V
Power dissipation <sup>Note 2)</sup>	P <sub>D</sub>	440	mW
Operating ambient temperature <sup>Note 1)</sup>	T <sub>opr</sub>	-20 to +70	°C
Storage temperature <sup>Note 1)</sup>	T <sub>stg</sub>	-55 to +125	°C

Note 1) T<sub>a</sub>=25°C for except ambient temperature and storage temperatures.

Note 2) Allowable power dissipation of the package at T<sub>a</sub>=70°C.

### ■ Recommended Operating Range (Ta=25°C)

Parameter	Symbol	Range
Operating supply voltage range (1)	PBV <sub>CC</sub>	4.5V to 5.5V
Operating supply voltage range (2)	RecV <sub>CC</sub>	8.5V to 12.5V

### ■ Electrical Characteristics (Ta=25±2°C)

Parameter	Symbol	Condition	min	typ	max	Unit
PB circuit current	I <sub>36</sub>	PB V <sub>CC</sub> =5V	—	—	56	mA
CH 1 gain	G <sub>4-26</sub>	PB V <sub>CC</sub> =5V	53	—	61	dB
CH 2 gain	G <sub>6-26</sub>	PB V <sub>CC</sub> =5V	53	—	61	dB
CH 3 gain	G <sub>11-26</sub>	PB V <sub>CC</sub> =5V	53	—	61	dB
CH 4 gain	G <sub>13-26</sub>	PB V <sub>CC</sub> =5V	53	—	61	dB
HSW change-over sensitivity	S <sub>1</sub>	PB V <sub>CC</sub> =5V	—	—	3.8	V
HASW change-over sensitivity	S <sub>34</sub>	PB V <sub>CC</sub> =5V	—	—	3.8	V
AGC output amplitude	V <sub>4-31</sub>	PB V <sub>CC</sub> =5V	130	—	270	mV <sub>P-P</sub>
AGC control sensitivity	ΔV <sub>4-31</sub>	PB V <sub>CC</sub> =5V	—	—	3.0	dB
HSW DC unbalance (I)	HSW <sub>26(I)</sub>	PB V <sub>CC</sub> =5V	—	—	100	mV <sub>P-P</sub>
HSW DC unbalance (II)	HSW <sub>26(II)</sub>	PB V <sub>CC</sub> =5V	—	—	100	mV <sub>P-P</sub>
HASW DC unbalance (I)	HASW <sub>26(I)</sub>	PB V <sub>CC</sub> =5V	—	—	100	mV <sub>P-P</sub>
HASW DC unbalance (II)	HASW <sub>26(II)</sub>	PB V <sub>CC</sub> =5V	—	—	100	mV <sub>P-P</sub>
Input conversion noise (1)	N <sub>4-26</sub> /G <sub>4-26</sub>	PB V <sub>CC</sub> =5V	—	—	1.0	μVrms
Input conversion noise (2)	N <sub>6-26</sub> /G <sub>6-26</sub>	PB V <sub>CC</sub> =5V	—	—	1.0	μVrms
Input conversion noise (3)	N <sub>11-26</sub> /G <sub>11-26</sub>	PB V <sub>CC</sub> =5V	—	—	1.0	μVrms
Input conversion noise (4)	N <sub>13-26</sub> /G <sub>13-26</sub>	PB V <sub>CC</sub> =5V	—	—	1.0	μVrms
Auto-tracking output at no-input	V <sub>21min.</sub>	PB V <sub>CC</sub> =4.8V	—	—	1.0	V
Auto tracking max. output	V <sub>21max.</sub>	PB V <sub>CC</sub> =4.8V	3.8	—	—	V
ENV output amplitude	V <sub>35</sub>	PB V <sub>CC</sub> =5V	3.5	—	—	V <sub>P-P</sub>
Rec. circuit current	I <sub>18</sub>	Rec V <sub>CC</sub> =12V	—	—	48	mA
SP Y-Rec. current output	I <sub>17</sub>	Rec V <sub>CC</sub> =12V	17	—	32	mA <sub>P-P</sub>
LP Y-Rec. current output ratio	I <sub>15</sub> /I <sub>17</sub>	Rec V <sub>CC</sub> =12V	-2.5	—	2.5	dB
SP 8MHz f characteristics ratio	I <sub>17H</sub> /I <sub>17</sub>	Rec V <sub>CC</sub> =12V	-4	—	—	dB
LP 8MHz f characteristics ratio	I <sub>15H</sub> /I <sub>15</sub>	Rec V <sub>CC</sub> =12V	-4	—	—	dB
Rec. chroma output ratio	I <sub>17C</sub> /I <sub>17</sub>	Rec V <sub>CC</sub> =12V	-15	—	-7	dB
PB circuit current	I <sub>36</sub>	PB V <sub>CC</sub> =5V	—	(43)	—	mA
CH 1 gain	G <sub>4-26</sub>	PB V <sub>CC</sub> =5V	—	(57)	—	dB
CH 2 gain	G <sub>6-26</sub>	PB V <sub>CC</sub> =5V	—	(57)	—	dB
CH 3 gain	G <sub>11-26</sub>	PB V <sub>CC</sub> =5V	—	(57)	—	dB
CH 4 gain	G <sub>13-26</sub>	PB V <sub>CC</sub> =5V	—	(57)	—	dB
AGC output amplitude	V <sub>4-31</sub>	PB V <sub>CC</sub> =5V	—	(200)	—	mV <sub>P-P</sub>
Rec circuit current	I <sub>18</sub>	Rec V <sub>CC</sub> =12V	—	(33)	—	mA
SP Y-Rec. current output	I <sub>17</sub>	Rec V <sub>CC</sub> =12V	—	(12)	—	mA <sub>P-P</sub>
Rec. chroma output ratio	I <sub>17C</sub> /I <sub>17</sub>	Rec V <sub>CC</sub> =12V	—	(-12)	—	dB
Rec. current 2nd harmonics distortion	D <sub>2f</sub>	Rec V <sub>CC</sub> =12V	—	(-43)	—	dB
Cross-modulation relative level	D <sub>M</sub>	Rec V <sub>CC</sub> =12V	—	(-48)	—	dB
Auto tracking SP output voltage (1)	V <sub>21SP1</sub>	PB V <sub>CC</sub> =4.8V, Vin=400mV <sub>P-P</sub>	(3.4)	—	(3.9)	V
Auto tracking SP output voltage (2)	V <sub>21SP2</sub>	PB V <sub>CC</sub> =4.8V, Vin=100mV <sub>P-P</sub>	(1.5)	—	(2.5)	V
Auto tracking LP output voltage difference	V <sub>21LP</sub> -V <sub>21SP2</sub>	PB V <sub>CC</sub> =4.8V	(0.1)	—	(0.5)	V

Note) The characteristics value in parentheses is not a guaranteed value, but reference one on design.

## ■ Functional Descriptions

### 1. Playback mode

- Pin36 (playback  $V_{CC}$ ) = 5V typ. (Pins15 and 17 are grounded internally)
- Pin18 (recording  $V_{CC}$ ) = open

#### (1) Selecting a head amplifier output channel

	Channel	Input pin	Head SW Pin1	HASW Pin34
SP	1	4	H	L
	2	6	L	L
LP	3	11	L	H
	4	13	H	H

#### (2) Starting the envelope comparator

Env. ON/OFF SW Pin2	Open	Low (special playback)
Env. comparator	Inactive	Active

#### (3) Automatic tracking interface

Pin24 (automatic tracking  $V_{CC}$ ) = 5V typ.

HASW(Pin24)	Automatic tracking
High	LP
Low	SP

- When the SP mode of the automatic tracking interface switches to the LP mode, the gain of the amplifier increases 5.5dB.
- When the gain control voltage at Pin23 increases, the gain of the circuit increases.

2. Recording mode

Pin18 (recording  $V_{CC}$ ) = 12V typ.

Pin36 (playback  $V_{CC}$ )  
Pin24 (automatic tracking  $V_{CC}$ ) } Opened or grounded

Pin35 : Recording internal bias current control

How to control :

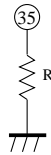

- When the external resistance decreases, the internal circuit bias current ( $I_{total}$ ) increases.
- R should be 27 to 33k $\Omega$ .

○ HASW control at Pin34

HASW Pin34	SP output	LP output	Pin11,13	Pin4,6	Pin19
H	OFF	active	GND	Diode	Open
L	active	OFF	Diode	GND	GND

■ Reference

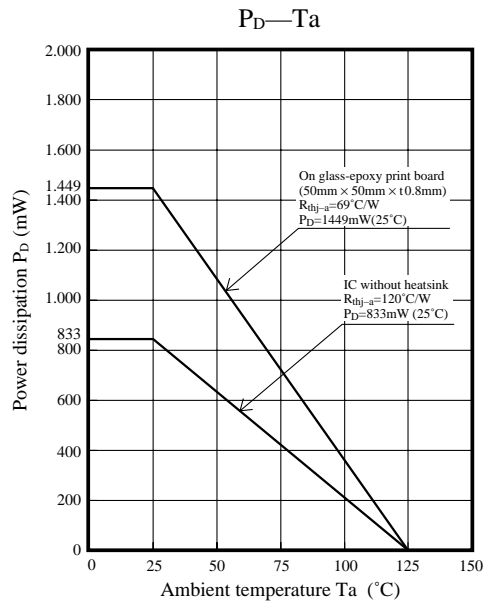



LittleDiode supplies new, hard to find or obsolete electronic components and semiconductors all over the world.

With over two million different components listed you are sure to find the part you need.

Feel free to visit us today at our online store:

[LittleDiode.com](http://LittleDiode.com)

Looking forward to providing you with the best possible service.