

AN3294K

Y/C Separation and Interface IC

Overview

The AN3294K is an IC developed for Y/C separation and I/O interface for the S-VHS VCR. The I/O circuits are integrated on single chip in order to meet with rationalization of set.

Features

- High-accuracy picture quality is prevented from deterioration at non-correlation by the color signal non-correlative-detection system.
- Built-in 75Ω drivers for Y, C, and Y+C.
- Built-in I/O selector switch for Y(C) component/composite signal.
- Character-insertion color-back function available for OSD.

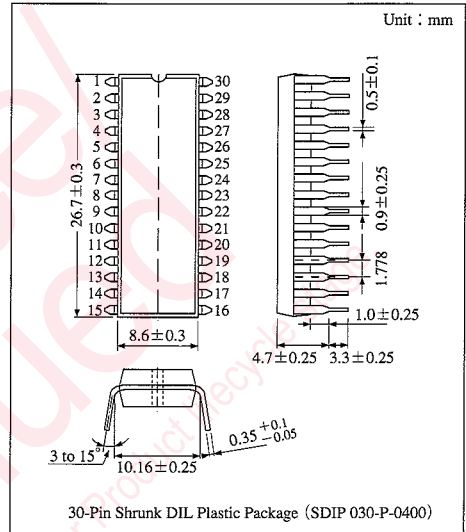

Block Diagram

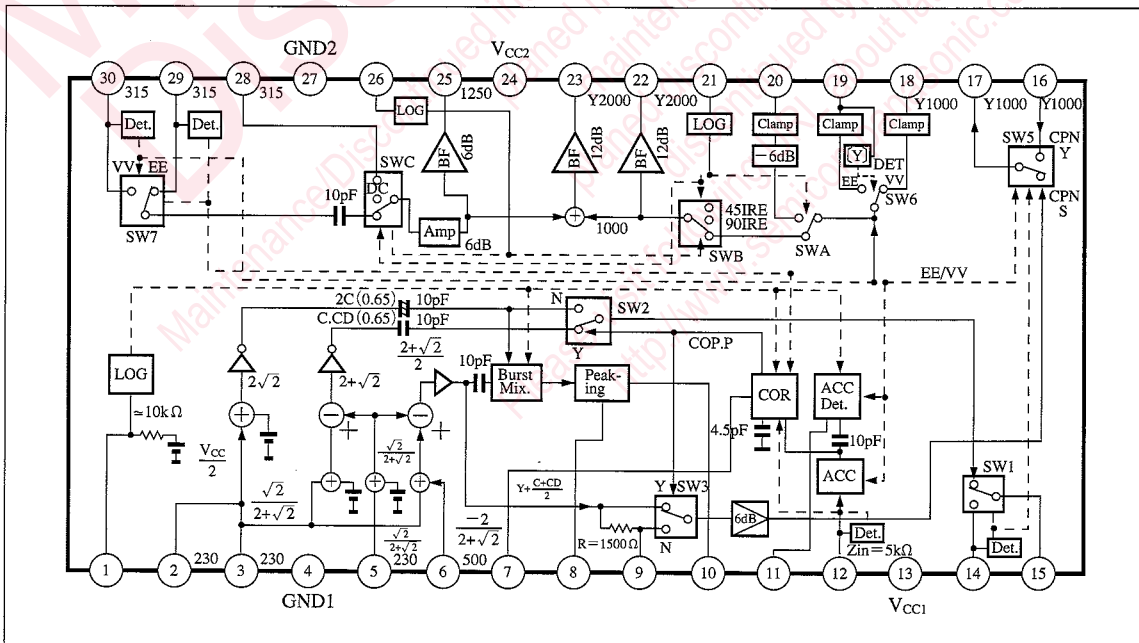

■ Absolute Maximum Ratings (Ta=25°C)

Parameter	Symbol	Rating	Unit
Supply voltage	V _{CC}	6	V
Power dissipation (Ta=70°C)	P _D	470	mW
Operating ambient temperature	T _{opr}	-20 to +70	°C
Storage temperature	T _{stg}	-55 to +150	°C

■ Recommended Operating Range (Ta=25°C)

Parameter	Symbol	Range
Operating supply voltage range	V _{CC}	4.5V to 5.5V

■ Electrical Characteristics (Ta=25°C)

Parameter	Symbol	Condition	min	typ*	max	Unit	Note
Circuit current (EE)	I ₁		45	(63)	79	mA	—
Circuit current (VV)	I ₁₃		43	(60)	76	mA	—
Y/C signal CCD input gain	G ₂₋₃	Pin ¹⁴ Hi, Pin ²⁹ Lo, Input 325mV _{PP} , f=5MHz	-1.5	(-0.2)	0.5	dB	—
C comb main-signal gain	G _{15-3M}	Input 325mV _{PP} , f=5MHz	2.8	(3.8)	4.8	dB	—
C comb sub-signal gain difference	ΔG ₁₅₋₅	Input 325mV _{PP} , f=5MHz	-1.1	(-0.4)	0.5	dB	—
C through signal gain difference	ΔG _{15-3T}	Pin ¹⁴ Hi, Pin ²⁹ Lo, Input 325mV _{PP} , f=5MHz	5.2	(6)	6.8	dB	—
C comb main-signal freq. characteristics	F _{15-3M}	Pin ¹⁴ Hi, Pin ²⁹ Lo, Input 325mV _{PP} , f=5M/1MHz	-1.5	(-0.5)	0.8	dB	—
CPN-C signal gain	G ₁₅₋₁₄	Pin ¹⁴ open, Input 650mV _{PP} , f=5MHz	-1.5	(-0.1)	0.8	dB	—
Y comb main-signal gain	G ₁₇₋₃	Pin ¹⁴ Hi, Pin ²⁹ Lo, Input 325mV _{PP} , f=5MHz	2.8	(3.7)	4.8	dB	—
Y comb Y. C. signal gain	G ₁₇₋₆	Pin ¹⁴ Hi, Pin ²⁹ Lo, Input 650mV _{PP} , f=5MHz	5.5	(6.5)	7.5	dB	—
Y comb sub-signal gain difference	ΔG ₁₇₋₅	Pin ¹⁴ Hi, Pin ²⁹ Lo, Input 325mV _{PP} , f=5MHz	-1.1	(-0.1)	0.5	dB	—
Y comb main-signal freq. characteristics	F ₁₇₋₃	Pin ¹⁴ Hi, Pin ²⁹ Lo, Input 325mV _{PP} , f=5M/1MHz	-1.5	(-0.2)	0.8	dB	—
CPN-Y signal gain	G ₁₇₋₁₆	Pin ¹⁴ open, Input 1000mV _{PP} , f=5MHz	-0.7	(-0.1)	0.3	dB	—
Chroma signal peaking gain	G _{10-3A}	Pin ¹⁴ open, Input 1000mV _{PP} , f=5MHz	-16	(-13.5)	-11	dB	Load 1kΩ
Chroma signal peaking gain difference	ΔG _{10-3B}	Pin ¹⁴ open, Input 1000mV _{PP} , f=5MHz	11.6	(12.7)	13.6	dB	Load 1kΩ
Chroma non-correlation detection level	S _{17-12A}	V ₇ =3.5V	4	(10)	17	mV _{PP}	—
VV Y signal gain	G ₂₂₋₁₈	Pin ²⁹ , Pin ³⁰ open, Video input 1V _{PP}	5.6	(6.4)	7	dB	—
EE Y signal gain	G ₂₂₋₁₉	Pin ²⁹ , Pin ³⁰ Hi, Video input 1V _{PP}	5.6	(6.4)	7	dB	—
Y+C, Y signal difference	ΔG ₂₃₋₁₉	Pin ²⁶ Lo, Pin ³⁰ Hi, Video input 1V _{PP}	-0.6	(-0.2)	0.4	dB	—
EE Y signal freq. characteristics	F ₂₂₋₁₉	Pin ²⁹ Lo, Pin ³⁰ Hi, Video input 1V _{PP} , f=5M/1MHz	-1	(-0.2)	1	dB	—
REP Y signal gain	G ₂₂₋₂₀	Pin ²⁶ Lo, Pin ²¹ Hi, Input 2V _{PP}	-0.4	(0.4)	1	dB	—
EE C signal gain	G ₂₅₋₂₉	Pin ²⁶ Lo, Pin ³⁰ Hi, Input 325mV _{PP} , f=3.58MHz	11.6	(12.3)	13.2	dB	—

* Values with an asterisk are typical ones and not guaranteed values.

ICs for
VCR

■ Electrical Characteristics (cont.) (Ta=25°C)

Parameter	Symbol	Condition	min	typ *	max	Unit	Note
Y+C, C signal gain difference	ΔG_{23-29}	Pin ²⁶ Lo, Pin ³⁰ Hi f=3.58MHz, Pin ¹⁹ =2.9V	-0.6	(-0.1)	0.6	dB	—
REP C signal gain	G_{25-28}	Pin ²⁶ Lo, Pin ³⁰ Hi f=3.58MHz, Pin ²⁰ =2.9V	12.9	(13.6)	14.5	dB	—
VV C signal gain	G_{25-30}	Pin ²⁶ Lo f=3.58MHz, Pin ¹⁸ =2.9V	11.6	(12.3)	13.2	dB	—
Character insertion level (90IRE)	V_{22-19A}	Pin ³⁰ Hi, Pin ²¹ Lo, Input 1V _{pp} Pin ²⁶ character input	74	(90)	100	IRE	—
BGP ON/OFF changeover Hi level	V_{1H}	Pin ¹ external resistor, R1=22k Ω	2.8	—	—	V	—
BGP ON/OFF changeover Lo level	V_{1L}	Pin ¹ external resistor, R1=22k Ω	—	—	2.2	V	—
Forced non-correlation changeover Lo level	V_{12L}	Pin ¹ external resistor, R1=22k Ω	—	—	1	V	—
CPS/CPN mode changeover Hi level	V_{14H}	Pin ¹ external resistor, R1=22k Ω	3.6	—	—	V	—
Forced VV input changeover Hi level at EE	V_{19H}	Pin ¹ external resistor, R1=22k Ω	4.8	—	—	V	—
OSD changeover Hi level	V_{21H}	Pin ¹ external resistor, R1=22k Ω	3.6	—	—	V	—
OSD changeover Mi level	V_{21M}	Pin ¹ external resistor, R1=22k Ω	1.4	—	3	V	—
OSD changeover Lo level	V_{21L}	Pin ¹ external resistor, R1=22k Ω	—	—	0.8	V	—
LET changeover Hi level	V_{26H}	Pin ¹ external resistor, R1=22k Ω	3	—	—	V	—
LET changeover Lo level	V_{26L}	Pin ¹ external resistor, R1=22k Ω	—	—	2	V	—
ACK mode changeover Lo level (ACK)	V_{29L}	Pin ¹ external resistor, R1=22k Ω	—	—	1.4	V	—
EE/VV mode changeover Hi level (EE)	V_{30H}	Pin ¹ external resistor, R1=22k Ω	3.6	—	—	V	—

* Values with an asterisk are typical ones and not guaranteed values.

■ Application Circuit

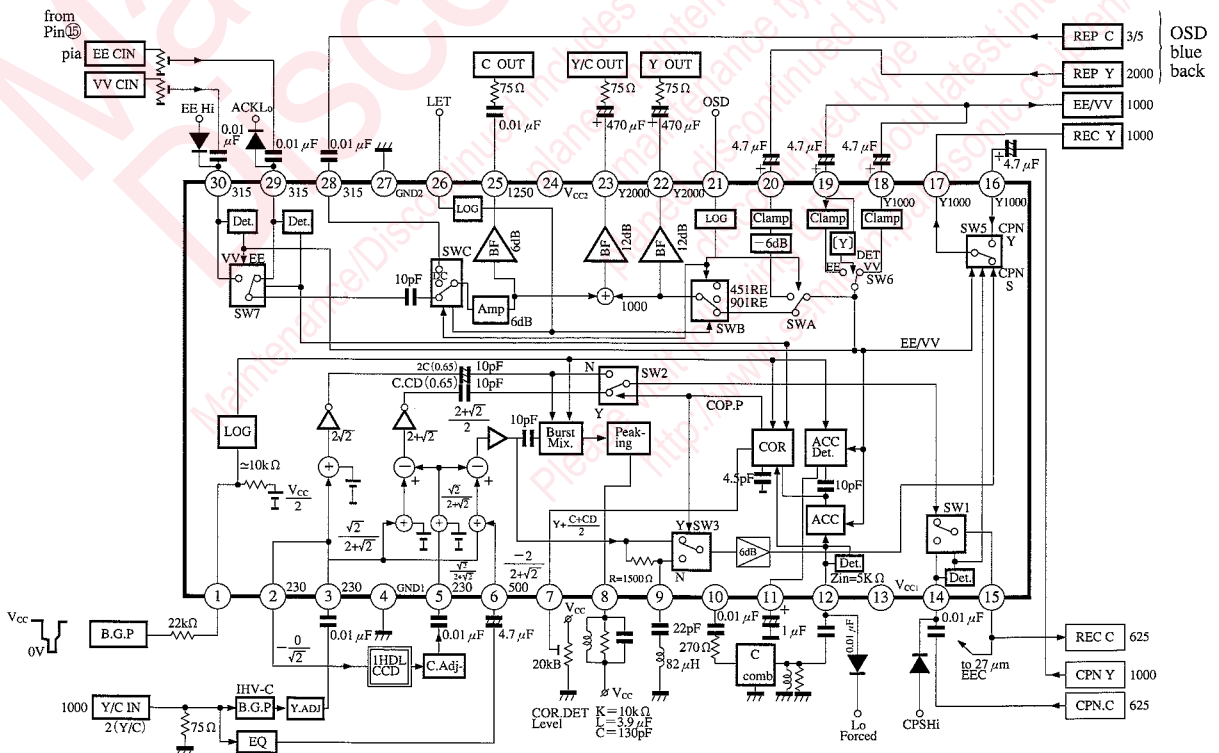

Pin Descriptions

Pin No.	Pin name	Typ. waveform	DC voltage	Z_{in}/Z_{out} (k Ω)	Pin No.	Pin name	Typ. waveform	DC voltage	Z_{in}/Z_{out} (k Ω)
1	B.G.P input		2.5	$Z_{in}10$	16	C.P.N Y signal input		2.3	$Z_{in}30$
2	Chroma signal output		2.5	E.F	17	Y separate output		2.3	E.F
3	Chroma signal input		1.75	$Z_{in}30$	18	VV Y AMP input		Sync. chip 2.3	Diode clamp
4	GND1	—	0	—	19	EE Y ANP input		Sync. chip 2.3	Diode clamp
5	1HDL chroma signal input		1.75	$Z_{in}30$	20	REP Y ANP		Sync. chip 2.3	Diode clamp
6	Composite video signal input		1.75	$Z_{in}30$	21	O.S.D mode changeover	3-value H/M/L	—	Base
7	Correlative detection level control	—	—	Z_{in} Base	22	Y AMP output		Sync. chip 1.5	to 0
8	3.58MHz peaking		5	—	23	Y + C AMP output		Sync. chip 1.4	to 0
9	3.58MHz trap		2.2	$Z_{OUT}1.5$	24	V_{CC3}	—	5	—
10	Peaking output		2	E.F	25	C AMP output		2.3	to 0
11	ACC DET	—	3	Z_{OUT} to 5	26	LET		—	Base
12	ACC input/forced non-correlation changeover		3	$Z_{in}5$	27	GND3	—	0	—
13	V_{CC1}	—	5	—	28	REP C input		3	$Z_{in}20$
14	CP.N chroma input CPS · CP.N changeover		2.2	$Z_{in}20$	29	EE C input		2.5	$Z_{in}20$
15	C separate output		2.3	E.F	30	VV C input		2.5	$Z_{in}20$

ICs for VCR

Supplementary Explanation

• Electrical Characteristics Design Reference Values ($T_a = 25^\circ\text{C}$)

Parameter	Symbol	Condition	min	typ	max	Unit
C through/C comb-main signal phase difference	ΔTd_{15-3M}	Input 325mV _{pp} , $f = 3.58\text{MHz}$ Pin ²⁹ Lo/Pin ²⁹ open Pin ²⁹ Lo	—	(2)	8	deg
Chroma non-correlation detection variable range	S _{17-12B}	$V_7 = 2.5\text{V}$ to 4V	2.5	—	4	V
EEY to VVY crosstalk	CT _{22-19A}	VV mode, Input 1000mV _{pp} , $f = 5\text{MHz}$	—	(-50)	-40	dB
EEC to VVC crosstalk	CT ₂₅₋₂₉	VV mode, Input 325mV _{pp} , $f = 3.58\text{MHz}$	—	(-50)	-40	dB
SW2DC unbalance	V_{15-12}	—	—	(5)	20	mV _{pp}
EE Y 2nd harmonics	2Y ₂₃₋₁₉	$f = 3.58\text{MHz}$	—	(-44)	-35	dB
EE C 2nd harmonics	2C ₂₃₋₁₉	$f = 3.58\text{MHz}$	—	(-42)	-35	dB

Note) Values with an asterisk are typical ones and not guaranteed values.

■ Supplementary Explanation (cont.)

• OSD Mode Selection Control Table

OSD Pin ^①	LET Pin ^②	SWA	SWB	SWC	Output	Output waveform Pin ^③
L	L	THRU	THRU	THRU	NORM	
	H		90IRE	DC	White superimposition	
M	L	THRU	THRU	THRU	NORM	
	H		45IRE	REP	White superimposition	
H	L	REP	THRU	REP	Color background	
	H		90IRE	DC	White Char. OSD	

OSD...Pin^① mode selector pin

LET...Pin^② character data input pin

SWA...Thru Y Pins^{⑬, ⑰}/REP Y Pin^⑳ selector switch

SWB...Thru/90IRE DC/45IRE DC selector switch

SWC...Thru Chroma Pin^{⑲, ⑳}/REP chroma Pin^⑳ selector switch

• Precautions on Use

1. Use this IC so that the Hi voltage (5V) is not applied to the ①, ⑦, ⑳, and ⑳ when the IC power is off.
2. The Pins^② and ⑦ are V_{CC} and GND for driver output (Pins^{②, ③, ⑤}), respectively. When designing the PCB, therefore, separate them from the other pins sufficiently in pattern design.
3. Pay attention to the handling because upside-down mounting makes over-current, and characteristics deterioration or damage may occur.
4. In the case, driver outputs (Pin^{②, ③, ⑤}) are used for energy saving, Pin^⑬ to ⑰ and Pin^⑲ should be opened.
In this case, only Y/C separation circuit operates and consumption current decreases by approximately 23mA at EE mode.

Request for your special attention and precautions in using the technical information and semiconductors described in this book

- (1) If any of the products or technical information described in this book is to be exported or provided to non-residents, the laws and regulations of the exporting country, especially, those with regard to security export control, must be observed.
- (2) The technical information described in this book is intended only to show the main characteristics and application circuit examples of the products. No license is granted in and to any intellectual property right or other right owned by Panasonic Corporation or any other company. Therefore, no responsibility is assumed by our company as to the infringement upon any such right owned by any other company which may arise as a result of the use of technical information described in this book.
- (3) The products described in this book are intended to be used for standard applications or general electronic equipment (such as office equipment, communications equipment, measuring instruments and household appliances).
Consult our sales staff in advance for information on the following applications:
 - Special applications (such as for airplanes, aerospace, automobiles, traffic control equipment, combustion equipment, life support systems and safety devices) in which exceptional quality and reliability are required, or if the failure or malfunction of the products may directly jeopardize life or harm the human body.
 - Any applications other than the standard applications intended.
- (4) The products and product specifications described in this book are subject to change without notice for modification and/or improvement. At the final stage of your design, purchasing, or use of the products, therefore, ask for the most up-to-date Product Standards in advance to make sure that the latest specifications satisfy your requirements.
- (5) When designing your equipment, comply with the range of absolute maximum rating and the guaranteed operating conditions (operating power supply voltage and operating environment etc.). Especially, please be careful not to exceed the range of absolute maximum rating on the transient state, such as power-on, power-off and mode-switching. Otherwise, we will not be liable for any defect which may arise later in your equipment.
 - Even when the products are used within the guaranteed values, take into the consideration of incidence of break down and failure mode, possible to occur to semiconductor products. Measures on the systems such as redundant design, arresting the spread of fire or preventing glitch are recommended in order to prevent physical injury, fire, social damages, for example, by using the products.
- (6) Comply with the instructions for use in order to prevent breakdown and characteristics change due to external factors (ESD, EOS, thermal stress and mechanical stress) at the time of handling, mounting or at customer's process. When using products for which damp-proof packing is required, satisfy the conditions, such as shelf life and the elapsed time since first opening the packages.
- (7) This book may be not reprinted or reproduced whether wholly or partially, without the prior written permission of our company.



LittleDiode supplies new, hard to find or obsolete electronic components and semiconductors all over the world.

With over two million different components listed you are sure to find the part you need.

Feel free to visit us today at our online store:

LittleDiode.com

Looking forward to providing you with the best possible service.