

AN3266FAP

Video luminance signal recording/playback processing IC

■ Overview

The AN3266FAP is a single chip IC in which the main signal processing part of VHS VCR luminance signal is integrated.

■ Features

- 5 V single power supply
- T2FP package

■ Applications

- VHS VCR, VHS video camera

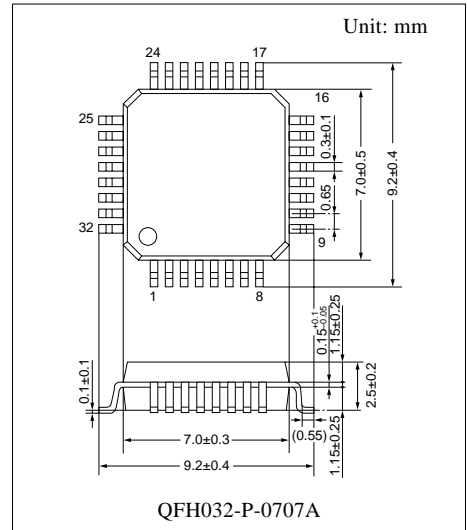

■ Block Diagram

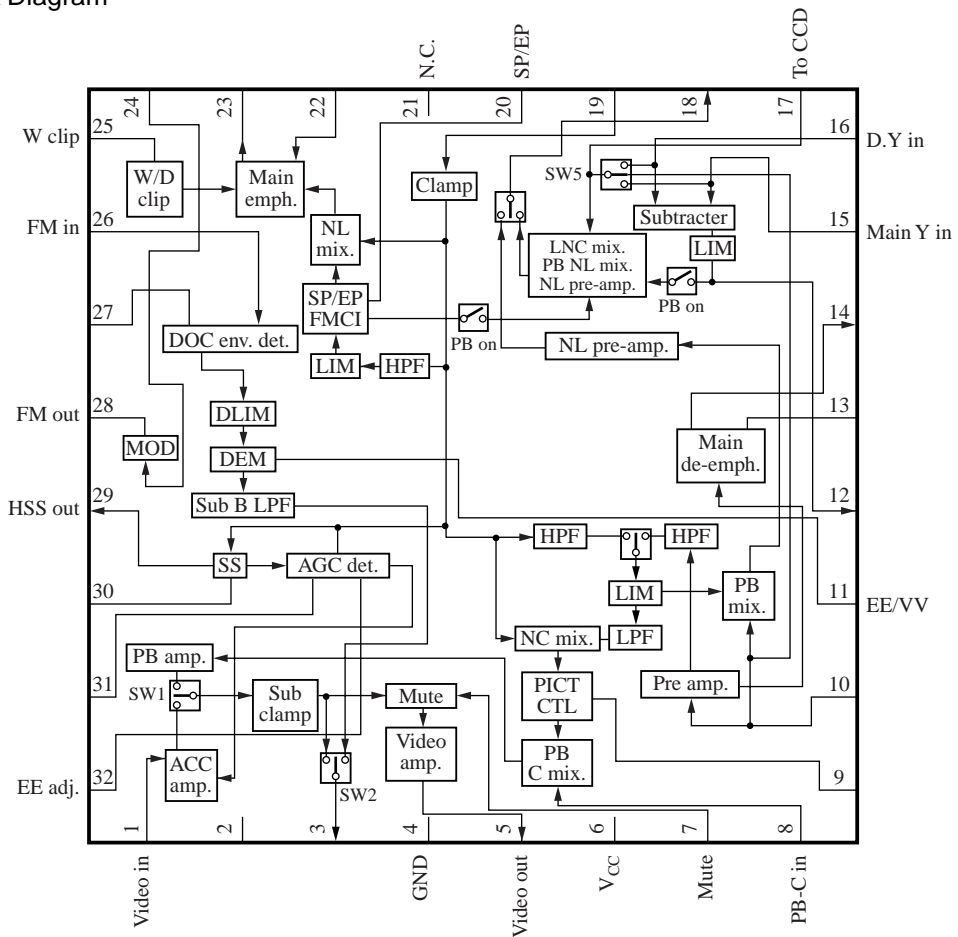

■ Pin Descriptions

Pin No.	Description	Pin No.	Description
1	Video in	17	To CCD out
2	Sub clamp det.	18	NL pre-emph. out
3	Sub clamp out (REC), Sub LPF out (PB)	19	Clamp in
4	GND	20	SP/EP select, FMCI CTL
5	Video out	21	N.C.
6	V _{CC}	22	NF input for main emph.
7	Mute CTL	23	Main emph. out
8	PB chroma in / DE off CTL	24	FM current in
9	Picture CTL	25	W clip CTL / LNC stop CTL
10	Signal input for main LPF	26	PB RF in
11	VV level adjust., EE / VV select.	27	Env. det.
12	LNC LIM out	28	REC FM out
13	Main de-emphasis	29	Sync. sepa. out
14	Main de-emphasis (out)	30	Sync. sepa. det.
15	Main Y sig. in	31	AGC det.
16	Delayed Y sig. in	32	EE adjust / NC off CTL

■ Absolute Maximum Ratings

Parameter	Symbol	Rating	Unit
Supply voltage	V _{CC}	6	V
Supply current	I _{CC}	68	mA
Power dissipation *2	P _D	208	mW
Operating ambient temperature *1	T _{opr}	-20 to +70	°C
Storage temperature *1	T _{stg}	-55 to +125	°C

Note) *1: Except for the operating ambient temperature and storage temperature, all ratings are for T_a = 25°C.











*2: The power dissipation shown is for the IC package in free air at T_a = 70°C.

P_D = 417 mW (T_a = 70°C) on mounting on a glass epoxy resin substrate of 50 × 50 × t0.8 mm³.





















■ Recommended Operating Range

Parameter	Symbol	Range	Unit
Supply voltage	V _{CC}	4.5 to 5.5	V





















■ Electrical Characteristics at $T_a = 25^\circ\text{C}$

Parameter	Symbol	Conditions	Min	Typ	Max	Unit
Circuit current (REC)	I_{CCR}	REC mode	30	42	54	mA
Circuit current (PB)	I_{CCP}	PB mode	38	50	62	mA
EE mode hold voltage	V_{EE}	$V_6 = \text{Variable}$	0	—	1.25	V
VV mode hold voltage	V_{VV}	$V_6 = \text{Variable}$	2.25	—	5	V
SP mode hold voltage	V_{SP}	$V_8 = \text{Variable}$	0	—	1.25	V
EP mode hold voltage	V_{EP}	$V_8 = \text{Variable}$	2.25	—	5	V
FMCI off mode hold voltage	V_{FM1}	$V_A = \text{Variable}$	2.25	—	3.25	V
FMCI on mode hold voltage	V_{FM2}	$V_A = \text{Variable}$	4.25	—	5	V
EDIT mode hold voltage at PB	V_{EDPB}	$V_1 = \text{Variable}$	0	—	1.25	V
Mute CTL Through mode hold voltage	$V_{THRU(PB)}$	$V_1 = \text{Variable}$	0	—	1	V
Mute CTL Quasi H mode hold voltage	V_{GRAY}	$V_B = \text{Variable}$	2	—	3	V
Mute CTL Quasi V mode hold voltage	V_{MUTE}	$V_3 = \text{Variable}$	4	—	5	V
EDIT mode hold voltage at REC	V_{EDREC}	$V_4 = \text{Variable}$	0	—	1.25	V
Off mode hold voltage at LNC	V_{LNC}	$V_9 = \text{Variable}$	0	—	1.25	V
Through mode hold voltage at EE	V_{THRU}	$V_3 = \text{Variable}$	0	—	1	V
Quasi H gray level offset	ΔV_5	PB mode	1.1	1.5	1.9	V
AGC output amplitude	V_{1-5}	 White 100% $V_{IN} = 1 \text{ V[p-p]}$	1.3	2.0	2.7	V[p-p]
AGC control sensitivity	ΔV_{1-5}	 White 100% $V_{IN} = 1 \text{ V[p-p]}$	0	0.3	1.2	dB
Video amp. frequency characteristics	f_{1-5}	 Sine wave 5 MHz / 100 kHz $V_{IN} = 250 \text{ mV[p-p]}$	-1.2	-0.5	0.5	dB
Main emphasis output level	V_{1-23}	 White 100% $V_{IN} = 1 \text{ V[p-p]}$	260	300	340	mV[p-p]
D-clip level	DV_{1-23}	—	45	55	65	%
Keyed pulse width	t_{W31}	 Sync. sig. $V_{IN} = 287 \text{ mV[p-p]}$	4.6	5.8	7.0	μs
SS minimum input sensitivity	S_{19}	 White 100% V_{IN} variable	—	—	450	mV[p-p]
SS pulse delay	t_{F29}	 $V_{IN} = 1 \text{ V[p-p]}$	460	660	860	ns
Over all gain for PB system	G_{10-5}	 White 100% $V_{IN} = 100 \text{ mV[p-p]}$	24	26	30	dB
Quasi V insertion step	ΔV_5	 White 100% $V_{IN} = 100 \text{ mV[p-p]}$	20	70	120	mV
Chroma amp. gain	G_{8-5}	 Sine wave $V_{IN} = 200 \text{ mV[p-p]}$	7.6	9.1	10.6	dB

















■ Electrical Characteristics at $T_a = 25^\circ\text{C}$ (continued)

Parameter	Symbol	Conditions	Min	Typ	Max	Unit
DE frequency characteristics 1 (0 dB)	$\Delta f_{10-18(1)}$	 Sine wave 500 kHz / 10 kHz $V_{IN} = 300 \text{ mV[p-p]}$	-0.5	0	1.0	dB
DE frequency characteristics 2 (0 dB)	$\Delta f_{10-18(2)}$	 Sine wave 2 MHz / 10 kHz $V_{IN} = 300 \text{ mV[p-p]}$	-0.5	0.15	1.15	dB
DE frequency characteristics 3 (-10 dB)	$\Delta f_{10-18(3)}$	 Sine wave 500 kHz / 10 kHz $V_{IN} = 94.9 \text{ mV[p-p]}$	-0.5	0.17	1.17	dB
DE frequency characteristics 4 (-10 dB)	$\Delta f_{10-18(4)}$	 Sine wave 2 MHz / 10 kHz $V_{IN} = 94.9 \text{ mV[p-p]}$	-0.5	0.45	1.45	dB
DE frequency characteristics 5 (-20 dB)	$\Delta f_{10-18(5)}$	 Sine wave 500 kHz / 10 kHz $V_{IN} = 30 \text{ mV[p-p]}$	-0.5	0.5	1.5	dB
DE frequency characteristics 6 (-20 dB)	$\Delta f_{10-18(6)}$	 Sine wave 2 MHz / 10 kHz $V_{IN} = 30 \text{ mV[p-p]}$	0.3	1.3	2.3	dB
DE frequency characteristics 7 (-30 dB)	$\Delta f_{10-18(7)}$	 Sine wave 500 kHz / 10 kHz $V_{IN} = 9.5 \text{ mV[p-p]}$	0	1.0	2.0	dB
DE frequency characteristics 8 (-30 dB)	$\Delta f_{10-18(8)}$	 Sine wave 2 MHz / 10 kHz $V_{IN} = 9.5 \text{ mV[p-p]}$	2.2	3.2	4.2	dB
DE off mode (-30 dB)	ΔG_{10-18}	 Sine wave 2 MHz $V_{IN} = 9.5 \text{ mV[p-p]}$	-4.2	-3.2	-2.2	dB
REC NL frequency characteristics 1 (0 dB)	$\Delta f_{19-23(1)}$	 Sine wave $V_{IN} = 1 \text{ V[p-p]}$ SP 500 kHz / 10 kHz	-0.5	0.5	1.5	dB
REC NL frequency characteristics 2 (0 dB)	$\Delta f_{19-23(2)}$	 Sine wave $V_{IN} = 1 \text{ V[p-p]}$ SP 1.5 MHz / 10 kHz	0	1.0	2.0	dB
REC NL frequency characteristics 3 (-10 dB)	$\Delta f_{19-23(3)}$	 Sine wave $V_{IN} = 316 \text{ mV[p-p]}$ SP 500 kHz / 10 kHz	0	1.0	2.0	dB
REC NL frequency characteristics 4 (-10 dB)	$\Delta f_{19-23(4)}$	 Sine wave $V_{IN} = 316 \text{ mV[p-p]}$ SP 1.5 MHz / 10 kHz	1.3	2.3	3.3	dB
REC NL frequency characteristics 5 (-20 dB)	$\Delta f_{19-23(5)}$	 Sine wave $V_{IN} = 100 \text{ mV[p-p]}$ SP 500 kHz / 10 kHz	0.1	1.1	2.1	dB
REC NL frequency characteristics 6 (-20 dB)	$\Delta f_{19-23(6)}$	 Sine wave $V_{IN} = 100 \text{ mV[p-p]}$ SP 1.5 MHz / 10 kHz	2.1	3.1	4.1	dB
REC NL frequency characteristics 7 (0 dB)	$\Delta f_{19-23(7)}$	 Sine wave $V_{IN} = 1 \text{ V[p-p]}$ EP 500 kHz / 10 kHz	0.3	1.3	2.3	dB
REC NL frequency characteristics 8 (0 dB)	$\Delta f_{19-23(8)}$	 Sine wave $V_{IN} = 1 \text{ V[p-p]}$ EP 1.5 MHz / 10 kHz	1.3	2.3	3.3	dB
REC NL frequency characteristics 9 (-10 dB)	$\Delta f_{19-23(9)}$	 Sine wave $V_{IN} = 316 \text{ mV[p-p]}$ EP 500 kHz / 10 kHz	1.3	2.3	3.3	dB
REC NL frequency characteristics 10 (-10 dB)	$\Delta f_{19-23(10)}$	 Sine wave $V_{IN} = 316 \text{ mV[p-p]}$ EP 1.5 MHz / 10 kHz	3.3	4.3	5.3	dB
REC NL frequency characteristics 11 (-20 dB)	$\Delta f_{19-23(11)}$	 Sine wave $V_{IN} = 100 \text{ mV[p-p]}$ EP 500 kHz / 10 kHz	1.6	2.6	3.6	dB
REC NL frequency characteristics 12 (-20 dB)	$\Delta f_{19-23(12)}$	 Sine wave $V_{IN} = 100 \text{ mV[p-p]}$ EP 1.5 MHz / 10 kHz	5.6	6.0	7.0	dB













■ Electrical Characteristics at $T_a = 25^\circ\text{C}$ (continued)

Parameter	Symbol	Conditions	Min	Typ	Max	Unit
PB NL frequency characteristics 1 (0 dB)	$\Delta f_{15-18(1)}$	 Sine wave $V_{IN} = 300 \text{ mV[p-p]}$ SP 500 kHz / 10 kHz	-1.6	-0.6	0.4	dB
PB NL frequency characteristics 2 (0 dB)	$\Delta f_{15-18(2)}$	 Sine wave $V_{IN} = 300 \text{ mV[p-p]}$ SP 1.5 MHz / 10 kHz	-2.0	-1.0	0	dB
PB NL frequency characteristics 3 (-10 dB)	$\Delta f_{15-18(3)}$	 Sine wave $V_{IN} = 94.9 \text{ mV[p-p]}$ SP 500 kHz / 10 kHz	-2.1	-1.1	-0.1	dB
PB NL frequency characteristics 4 (-10 dB)	$\Delta f_{15-18(4)}$	 Sine wave $V_{IN} = 94.9 \text{ mV[p-p]}$ SP 1.5 MHz / 10 kHz	-3.5	-2.5	-1.5	dB
PB NL frequency characteristics 5 (-20 dB)	$\Delta f_{15-18(5)}$	 Sine wave $V_{IN} = 30 \text{ mV[p-p]}$ SP 500 kHz / 10 kHz	-2.2	-1.2	-0.2	dB
PB NL frequency characteristics 6 (-20 dB)	$\Delta f_{15-18(6)}$	 Sine wave $V_{IN} = 30 \text{ mV[p-p]}$ SP 1.5 MHz / 10 kHz	-4.2	-3.2	-2.2	dB
PB NL frequency characteristics 7 (0 dB)	$\Delta f_{15-18(7)}$	 Sine wave $V_{IN} = 300 \text{ mV[p-p]}$ EP 500 kHz / 10 kHz	-2.3	-1.3	-0.3	dB
PB NL frequency characteristics 8 (0 dB)	$\Delta f_{15-18(8)}$	 Sine wave $V_{IN} = 300 \text{ mV[p-p]}$ EP 1.5 MHz / 10 kHz	-3.3	-2.3	-1.2	dB
PB NL frequency characteristics 9 (-10 dB)	$\Delta f_{15-18(9)}$	 Sine wave $V_{IN} = 94.9 \text{ mV[p-p]}$ EP 500 kHz / 10 kHz	-3.3	-2.3	-1.3	dB
PB NL frequency characteristics 10 (-10 dB)	$\Delta f_{15-18(10)}$	 Sine wave $V_{IN} = 94.9 \text{ mV[p-p]}$ EP 1.5 MHz / 10 kHz	-6.0	-5.0	-4.0	dB
PB NL frequency characteristics 11 (-20 dB)	$\Delta f_{15-18(11)}$	 Sine wave $V_{IN} = 30 \text{ mV[p-p]}$ EP 500 kHz / 10 kHz	-3.5	-2.5	-1.5	dB
PB NL frequency characteristics 12 (-20 dB)	$\Delta f_{15-18(12)}$	 Sine wave $V_{IN} = 30 \text{ mV[p-p]}$ EP 1.5 MHz / 10 kHz	-6.7	-5.7	-4.7	dB
NC frequency characteristics 1 (0 dB)	$\Delta f_{19-5(1)}$	 Sine wave $V_{IN} = 1 \text{ V[p-p]}$ 1 MHz / 10 kHz	-1.4	-0.4	0.6	dB
NC frequency characteristics 2 (0 dB)	$\Delta f_{19-5(2)}$	 Sine wave $V_{IN} = 1 \text{ V[p-p]}$ 2 MHz / 1 MHz	-1.1	-0.1	0.9	dB
NC frequency characteristics 3 (-10 dB)	$\Delta f_{19-5(3)}$	 Sine wave $V_{IN} = 316 \text{ mV[p-p]}$ 1 MHz / 10 kHz	-2.0	-1.0	0	dB
NC frequency characteristics 4 (-10 dB)	$\Delta f_{19-5(4)}$	 Sine wave $V_{IN} = 316 \text{ mV[p-p]}$ 2 MHz / 1 MHz	-0.8	0.2	1.2	dB
NC frequency characteristics 5 (-20 dB)	$\Delta f_{19-5(5)}$	 Sine wave $V_{IN} = 100 \text{ mV[p-p]}$ 1 MHz / 10 kHz	-3.3	-2.3	-1.3	dB
NC frequency characteristics 6 (-20 dB)	$\Delta f_{19-5(6)}$	 Sine wave $V_{IN} = 100 \text{ mV[p-p]}$ 2 MHz / 1 MHz	-0.5	0.5	1.5	dB
NC frequency characteristics 7 (-30 dB)	$\Delta f_{19-5(7)}$	 Sine wave $V_{IN} = 31.6 \text{ mV[p-p]}$ 1 MHz / 10 kHz	-10	-6.3	-4.3	dB
NC frequency characteristics 8 (-30 dB)	$\Delta f_{19-5(8)}$	 Sine wave $V_{IN} = 31.6 \text{ mV[p-p]}$ 2 MHz / 1 MHz	0.2	2.2	6.2	dB
NC off mode	ΔG_{19-5}	 Sine wave $V_{IN} = 31.6 \text{ mV[p-p]}$ 1 MHz	4.3	6.3	10.0	dB

■ Electrical Characteristics at $T_a = 25^\circ\text{C}$ (continued)

Parameter	Symbol	Conditions	Min	Typ	Max	Unit
LNC attenuation level 1	$\Delta G_{15-18(1)}$	(19 input off)  Sine wave (19 input on) 10 kHz	-12.3	-9.3	-5	dB
LNC attenuation level 2	$\Delta G_{15-18(2)}$	(19 input off)  Sine wave (19 input on) 3 kHz	-8.1	-6.1	-3.1	dB
LNC off mode	ΔV_{15-18}	 Sine wave V_9 1.35 V 2.15 V 10 kHz	-1	0	1	dB
LNC LIM output amplitude	V_{LNC}	 Sine wave $V_{IN} = 300$ mV[p-p] 100 kHz	34	44	58	mV[p-p]
LNC LIM gain	G_{LNC}	 Sine wave $V_{IN} = 9.5$ mV[p-p] 100 kHz	3.7	6.7	8.7	mV[p-p]
Pic. cont. frequency characteristics 1 (forced)	$\Delta f_{19-5(1)}$	 Sine wave $V_{IN} = 500$ mV[p-p] 3 MHz / 100 kHz	4.9	5.9	7.4	dB
Pic. cont. frequency characteristics 2 (attenuated)	$\Delta f_{19-5(2)}$	 Sine wave $V_{IN} = 1$ V[p-p] 3 MHz / 100 kHz	-14	-11	-8	dB
FM oscillation output amplitude	V_{28}	$I_{IN} = 280$ μA	0.85	1.0	1.3	V[p-p]
FM oscillation secondary harmonic	$2f_{28}$	$I_{IN} = 280$ μA	—	—	-33	dB
FM oscillation frequency	f_{28}	$I_{IN} = 280$ μA	3.1	3.5	3.9	MHz
FM oscillation control sensitivity	β_{28}	$\frac{f(500 \mu\text{A}) - f(160 \mu\text{A})}{500 \mu\text{A} - 160 \mu\text{A}}$	11.5	13	15.0	MHz/ μA
FM carrier interleave 1	ΔV_{20-23}	 $V_{IN} = 5$ V[p-p]	1.35	2.35	3.35	mV[p-p]
DEM demodulation sensitivity 1	$S_{3(1)}$	 Sine wave $V_5 = 2.5$ V $V_{IN} = 350$ mV[p-p] $f_{IN} = 3$ MHz to 5 MHz	40	69	100	mV/MHz
DEM demodulation sensitivity 2	$S_{3(2)}$	 Sine wave $V_5 = 3.5$ V $V_{IN} = 350$ mV[p-p] $f_{IN} = 3$ MHz to 5 MHz	75	105	135	mV/MHz
DEM demodulation limit	Lf_{26-3}	 Sine wave $V_{IN} = 350$ mV[p-p]	7.5	—	—	MHz
DEM carrier leak	CL_{26-3}	 Sine wave $V_{IN} = 350$ mV[p-p] $f_{IN} = 2$ MHz \rightarrow 2 MHz / 4 MHz	—	—	-25	dB
Sub LPF frequency characteristics	Δf_{26-3}	 Sine wave f_{IN} $V_{IN} = 350$ mV[p-p]	-8	-6.2	-4.5	dB
DOC det. on	S_{26}	 Sine wave $f_{IN} = 4$ MHz	-20	-16	-11	dB
DOC det. off (hysteresis)	ΔS_{26}	 Sine wave $f_{IN} = 4$ MHz	0.2	1.5	6	dB
DOC offset	ΔV_{18}	 $V_{IN} = 350$ mV[p-p] or 0 mV[p-p] $f_{IN} = 4$ MHz	-15	0	15	mV[p-p]

■ Electrical Characteristics at $T_a = 25^\circ\text{C}$ (continued)

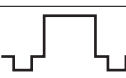
Parameter	Symbol	Conditions	Min	Typ	Max	Unit
DOC pulse width	t_{W18}	 $V_{IN} = 350 \text{ mV[p-p]}$ or 0 mV[p-p] $f_{IN} = 4 \text{ MHz}$	35.5	37.45	39.5	μs
DOC SW crosstalk	CT_{16-17}	 Sine wave DOC off $V_{IN} = 300 \text{ mV[p-p]}$ $f_{IN} = 100 \text{ kHz}$	—	—	-35	dB
Quasi V mute crosstalk	CT_{19-5}	 Sine wave $V_{IN} = 1 \text{ V[p-p]}$ $f_{IN} = 2 \text{ MHz}$	—	—	-35	dB
SW1 crosstalk 1	CT_{19-5}	 Sine wave $V_{IN} = 1 \text{ V[p-p]}$ $f_{IN} = 2 \text{ MHz}$	—	—	-40	dB
SW1 crosstalk 2	CT_{1-5}	 Sine wave $V_{IN} = 250 \text{ mV[p-p]}$ $f_{IN} = 2 \text{ MHz}$	—	—	-40	dB
SW2 crosstalk 1	CT_{26-3}	 Sine wave PB 2 MHz $V_{IN} = 350 \text{ mV[p-p]}$ REC 4 MHz	—	—	-40	dB
SW2 crosstalk 2	CT_{1-3}	 Sine wave $V_{IN} = 250 \text{ mV[p-p]}$ $f_{IN} = 2 \text{ MHz}$	—	—	-40	dB
SW5 crosstalk 1	CT_{15-18}	 Sine wave $V_{IN} = 250 \text{ mV[p-p]}$ $f_{IN} = 2 \text{ MHz}$	—	—	-40	dB
SW5 crosstalk 2	CT_{17-18}	 Sine wave $V_{IN} = 300 \text{ mV[p-p]}$ $f_{IN} = 2 \text{ MHz}$	—	—	-40	dB
White mute crosstalk	CT_{1-5}	 Sine wave $V_{IN} = 300 \text{ mV[p-p]}$ $f_{IN} = 2 \text{ MHz}$	—	—	-40	mV[p-p]
FM carrier interleave 2	ΔV_{20-18}	 Sine wave $V_{IN} = 5 \text{ V[0-p]}$ $f_{IN} = 2 \text{ MHz}$	4	7.5	1	mV
Pi cont. off mode	ΔG_{19-5}	 Sine wave $V_{IN} = 1 \text{ V[p-p]}$ $f_{IN} = 3 \text{ MHz}$	4.4	5.9	7.4	dB
SS pulse output amplitude	V_{29}	 White 100% $V_{IN} = 1 \text{ V[p-p]}$	4.3	—	—	V[p-p]



LittleDiode supplies new, hard to find or obsolete electronic components and semiconductors all over the world.

With over two million different components listed you are sure to find the part you need.

Feel free to visit us today at our online store:

LittleDiode.com

Looking forward to providing you with the best possible service.