



### ■ Pin

Pin No.	Pin Name	Pin No.	Pin Name
1	500kHz Osc. (1)	10	GND
2	500kHz Osc. (2)	11	Video→TPSG SW Output
3	SIF Osc. (1)	12	Video Input
4	Audio Input	13	Video Clamp Input
5	SIF Osc. (2)	14	Video Bias Adj.
6	V <sub>CC1</sub>	15	Video Bias Output
7	Voltage Reg. Output	16	Video Output
8	V <sub>CC2</sub>	17	TPSG SW
9	SIF Output	818	GND

### ■ Absolute Maximum Ratings (Ta=25°C)

Item	Symbol	Rating	Unit
Supply voltage	V <sub>CC</sub>	10	V
Supply current	I <sub>CC</sub>	35	mA
Power dissipation	P <sub>D</sub>	350	mW
Operating ambient temperature	T <sub>opr</sub>	-20~+70	°C
Storage temperature	T <sub>stg</sub>	-55~+150	°C

### ■ Electrical Characteristics (V<sub>CC</sub>=9V Ta=25°C)

Item	Symbol	Test Circuit	Condition	min.	typ.	max.	Unit
Supply current	I <sub>CC</sub>	1	TPSG On	15	20	25	mA
Stabilized power output	V <sub>7</sub>	1		6.4	6.9	7.4	V
Stabilized power stability	ΔV <sub>7</sub>	1	V <sub>CC</sub> =8~10V	-0.2		+0.2	V
Video modulation degree	m	1	Pin⑭ Open	77.5	82.5	87.5	%
Video output amplitude	V <sub>O</sub>	1	V <sub>in</sub> =0.6V <sub>p-p</sub>	0.58	0.60	0.62	V <sub>p-p</sub>
Max. video modulation degree	m <sub>max.</sub>	1	Pin⑭ Open	90	100	110	%
Differential gain	DG	1	m=77.5%	-3		+3	%
Differential phase	DP	1	m=77.5%	-3		+3	deg
Video S/N	SN	1	m=82.5%	55			dB
TP output amplitude	v <sub>O(TP)</sub>	1		0.59	0.63	0.67	V <sub>p-p</sub>
V/S ratio	V/S	1		75:25	70:30	65:35	
TP modulation degree	m <sub>TP</sub>	1	Pin⑭ Open	80	87	95	%
SIF frequency	f <sub>S</sub>	1		5.40	5.50	5.60	MHz
SIF output level	V <sub>S</sub>	1	Pin⑨ Open	108	109	110	dBμ
Sound FM modulation sensitivity	Δf <sub>FM</sub>	1		±35	±50	±65	kHz
Sound FM modulation distortion	THD					1.0	%

Test Circuit 1

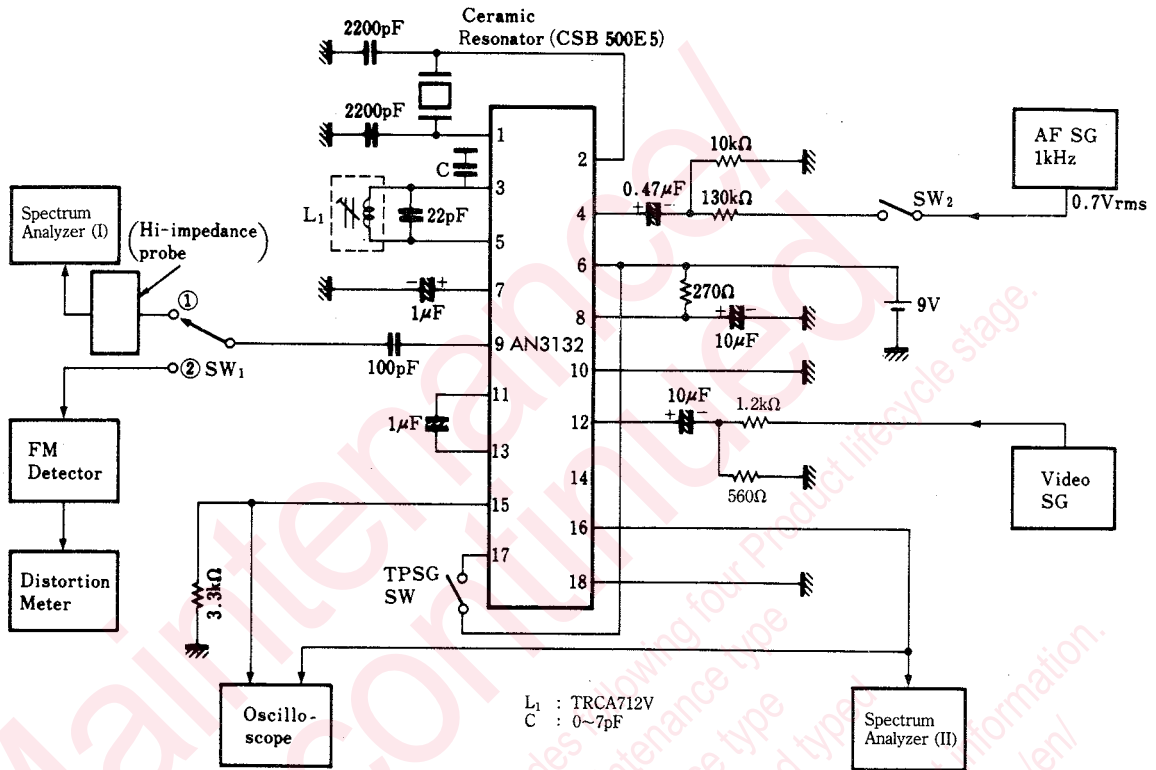

Measuring Conditions List

Item	Input Condition		Measuring Method	Measuring Pin	SW	
	Video SG	AF SG			1	2
m	10-step wave, 2V <sub>P-P</sub>	—	$m = b/a \times 100$ $V_o = b$	⑮-⑯	—	—
m <sub>max</sub>	10-step wave, 3V <sub>P-P</sub>	—		⑮-⑯	—	—
V <sub>o</sub>	10-step wave, 2V <sub>P-P</sub>	—	Measure with an oscilloscope.	⑮-⑯	—	—
DG	10-step wave, 2V <sub>P-P</sub>	—	Measure with a vectorscope.	⑯	—	—
GP	10-step wave, 2V <sub>P-P</sub>	—	Measure with a vectorscope.	⑯	—	—
SN	10-step wave, 2V <sub>P-P</sub>	—	Measure with a noise meter.	⑯	—	—
V <sub>TP</sub>	10-step wave, 2V <sub>P-P</sub>	—	Measure with an oscilloscope.	⑯	—	—
V/S	10-step wave, 2V <sub>P-P</sub>	—	Measure with an oscilloscope.	⑯	—	—
m <sub>TP</sub>	10-step wave, 2V <sub>P-P</sub>	—	Measure with an oscilloscope and calculate in the same manner as m.	⑮-⑯	—	—
f <sub>S</sub>	—	—	Measure a frequency with a spectrum analyzer(I).	⑨	①	—
V <sub>S</sub>	—	—	Measure a 5.5 MHz level with a spectrum analyzer(I).	⑨	①	—
Δf <sub>FM</sub>	—	1 kHz, 0.7Vrms	Measure with a modulation analyzer.	⑨	②	ON
THD	—	1 kHz, 0.7Vrms	Measure with a distortion gauge.	⑨	②	ON

## Request for your special attention and precautions in using the technical information and semiconductors described in this book

- (1) If any of the products or technical information described in this book is to be exported or provided to non-residents, the laws and regulations of the exporting country, especially, those with regard to security export control, must be observed.
- (2) The technical information described in this book is intended only to show the main characteristics and application circuit examples of the products. No license is granted in and to any intellectual property right or other right owned by Panasonic Corporation or any other company. Therefore, no responsibility is assumed by our company as to the infringement upon any such right owned by any other company which may arise as a result of the use of technical information described in this book.
- (3) The products described in this book are intended to be used for standard applications or general electronic equipment (such as office equipment, communications equipment, measuring instruments and household appliances).  
Consult our sales staff in advance for information on the following applications:
  - Special applications (such as for airplanes, aerospace, automobiles, traffic control equipment, combustion equipment, life support systems and safety devices) in which exceptional quality and reliability are required, or if the failure or malfunction of the products may directly jeopardize life or harm the human body.
  - Any applications other than the standard applications intended.
- (4) The products and product specifications described in this book are subject to change without notice for modification and/or improvement. At the final stage of your design, purchasing, or use of the products, therefore, ask for the most up-to-date Product Standards in advance to make sure that the latest specifications satisfy your requirements.
- (5) When designing your equipment, comply with the range of absolute maximum rating and the guaranteed operating conditions (operating power supply voltage and operating environment etc.). Especially, please be careful not to exceed the range of absolute maximum rating on the transient state, such as power-on, power-off and mode-switching. Otherwise, we will not be liable for any defect which may arise later in your equipment.
  - Even when the products are used within the guaranteed values, take into the consideration of incidence of break down and failure mode, possible to occur to semiconductor products. Measures on the systems such as redundant design, arresting the spread of fire or preventing glitch are recommended in order to prevent physical injury, fire, social damages, for example, by using the products.
- (6) Comply with the instructions for use in order to prevent breakdown and characteristics change due to external factors (ESD, EOS, thermal stress and mechanical stress) at the time of handling, mounting or at customer's process. When using products for which damp-proof packing is required, satisfy the conditions, such as shelf life and the elapsed time since first opening the packages.
- (7) This book may be not reprinted or reproduced whether wholly or partially, without the prior written permission of our company.



LittleDiode supplies new, hard to find or obsolete electronic components and semiconductors all over the world.

With over two million different components listed you are sure to find the part you need.

Feel free to visit us today at our online store:

[LittleDiode.com](http://LittleDiode.com)

Looking forward to providing you with the best possible service.