

RELAY DRIVE PROTECTION

A fast switch-off in an inductive circuit causes overvoltages and electromagnetic interferences that can damage peripheral elements. When a relay drive circuit is not protected, it is frequent to find some contacts destroyed by the arc due to the overvoltage or failed transistors after initial use. Various solutions exist which limit the voltage at the terminals of the switching circuit in order to prevent any damage.

There follow some examples.

1. PASSIVE COMPONENTS

Resistive network, capacitor (circuit a, fig.1)

This is an efficient solution in many applications but generates current peaks that can be inconvenient at switch-on.

Figure 1 : Relay Drive Protection by R.C. Network

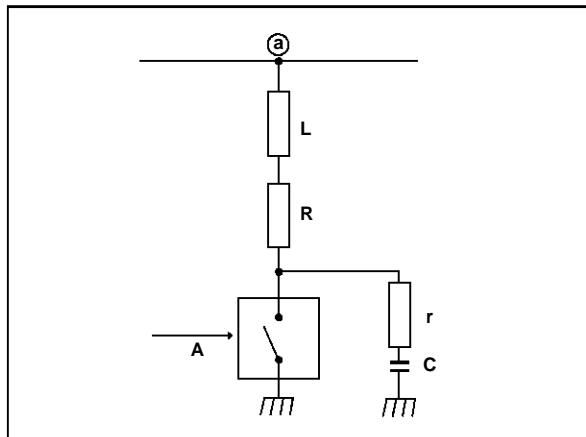

2. ELECTRONIC COMPONENTS

1) FAST DIODES AND TRANSIL

Standard protection which puts a diode in antiparallel with the inductive load (circuit b, fig.2) offers many advantages : negligible overvoltage at switch on (forward voltage of the diode) reduced space, low price, good reliability and negligible permanent losses.

Unfortunately the current through the inductor does not stop immediately at switch-off ; instead it decays with a time constant L/R . This is a disadvantage in some applications, for example a relay coil driver. The relay contacts will remain closed for some time after the switch is opened due to the current stored in the relay coil. It would be desirable to speed up the current decay rate while retaining the advantages of recovery diode protection.

A solution is shown in fig.2, circuit C, in which a Transil diode is put in series with the recovery device. A much higher voltage is developed across the diode-Transil combination than across a single diode, thus accelerating the current decay.

Figure 2 : Relay Drive Protection by :

- b) Recovery Diode
- c) Diode and Transil

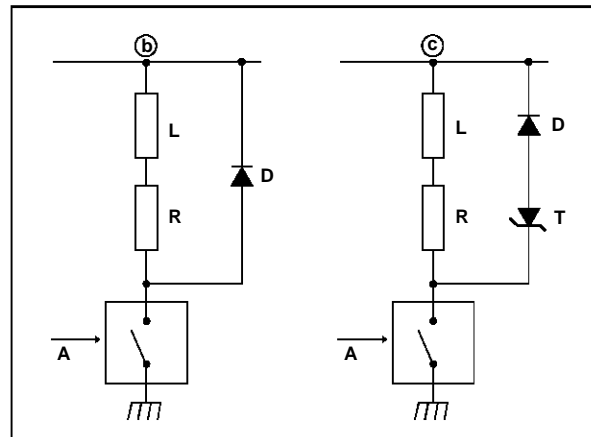

2) TRANSIL

The Transil is an avalanche diode specially designed to clamp overvoltages and dissipate power in impulsive mode. It also offers the possibility of considerable average power absorption. It is available in different cases covering a wide range of voltages (5 to 600V). Moreover, all the necessary data to calculate power parameters and to carry out temperature evaluation (Z_{th} , R_{th} , etc...) can be found in technical notes. So the Transil is perfectly suited to this application.

APPLICATION NOTE

In the case of a steady state power supply we can consider three hypotheses :

- Circuit d (fig.3). This is an economic solution which requires a unidirectional Transil only, but the current released by the inductance goes through the power supply and may affect the ground points.

- Circuit c (fig.2) and circuit e (fig.3). The inductive discharge current only goes through the LRD loop, thus it does not create disturbances in the ground points. This is a more expensive solution since two diodes or one bidirectional Transil are necessary. In the case of an alternating sinusoidal supply for low power, circuits e and f (fig.3) are well suited to limit inductive overvoltages.

3) COMPARISON OF THE CURRENT DECAY TIME IN THE INDUCTIVE LOAD BETWEEN THE RECOVERY DIODE AND THE TRANSIL DIODE SCHEMATICS (fig.4)

The ratio t_2/t_1 represents the reduction in current decay time when a Transil is used.

$$t_2/t_1 = \frac{1}{1 + 1.4 V_{CL}/V_{CC}}$$

Figure 3 : Relay Drive Protection by :
d) Unidirectional Transil
e) Bidirectional Transil
f) Bidirectional Transil

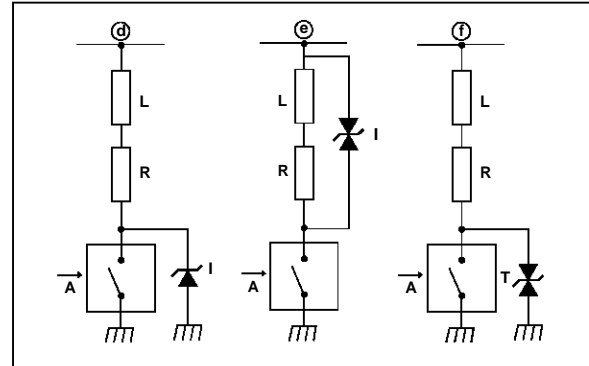

V_{CL} is the voltage (measured) at the terminals of the Transil when the load current goes through it.

If we take $V_{CL} \approx V_{CC}$, we limit the overvoltage to a reasonable value and thus period t_2 represents only $0.4 \times t_1$. A correct choice of V_{CL} will reduce t_2 to very low values and reach the mechanical limit given by the relay.

Figure 4 : Current in the inductance at switch off :
g) Recovery diode circuit : current slowly decreases to 0.

h) Transil circuit : current decreases rapidly. (asymptote = $-\frac{V_{CL}^*}{R}$)

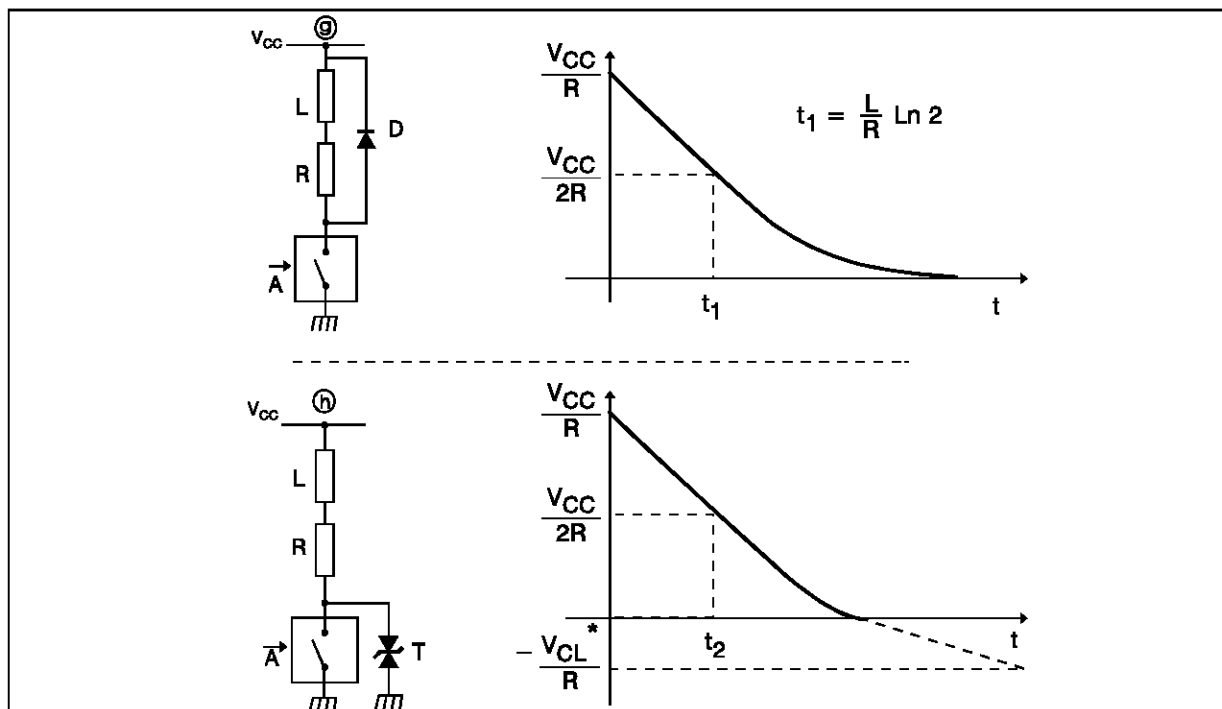

3. CONCLUSION

The Transil is a must in relay drive circuits. It guarantees a reliable and efficient protection while reducing the delay between the coil drive turn-off and the contact release.

4. EXAMPLE OF APPLICATION : Calculation and choice of a Transil

We wish to protect the transistor in figure 5 by a Transil whose clamping voltage must not under any circumstances exceed $V_{CL} = 85 \text{ V}$

The clamping voltage is given by :

$$V_{CL} = V_{BR} + R_d I_c$$

In the case of repetitive overload, the current is small enough such that the $R_d I_c$ term can be neglected. Thus V_{CL} approximates to :

$$V_{CL} \approx V_{BR}$$

The calculation is therefore simplified, and the Transil can be selected according to its thermal resistance.

1) MEAN POWER DETERMINATION : P_{AV}

A rough value can be obtained by assuming that all the energy contained in the inductance is absorbed by the Transil.

This is true when $V_{BR} \gg V_{CC}$.

$$P_{AV} = \frac{1}{2} L I^2 f = \frac{1}{2} 0.35 \left(\frac{12 + 2.4}{45} \right)^2 50 = 0.9 \text{ W}$$

2) STAND OFF VOLTAGE SELECTION

The supply voltage varies between 9.6 V and 14.4 V.

The stand off voltage of the diode V_{RM} will be therefore be greater than or equal to 14.4 V.

3) V_{CL} DETERMINATION

From the data sheets we can see that for a low current, $V_{CL} = V_{BR}$

4) T_j CALCULATION

$$T_j = T_{amb} + P_{AV} \times R_{th} = 50 + 90 = 140^\circ\text{C} < T_{j \text{ max}} (150^\circ\text{C})$$

This value is consistent with the characteristics of the BZW04- 61B Transil (F 126 case) but the safety margin is somewhat low, so a device from the 1500 W series is preferable as a first choice.

$$\left\{ \begin{array}{l} 1.5 \text{ KE 75CP (CB- 429 case) } V_{BR \text{ max}} = 82.5 \text{ V,} \\ R_{th} = 75^\circ\text{C/W, } V_{RM} = 64.1 \text{ V} > 14.4 \text{ V} \end{array} \right.$$

$$T_j = 50 + 68 = 118^\circ\text{C} \quad T_{j \text{ max}} = 175^\circ\text{C}$$

5) TEMPERATURE CORRECTION

Voltage at 118°C is :

$$V_{CL} (118^\circ\text{C}) = V_{CL} (25^\circ\text{C}) [1 + \alpha T (118 - 25)] = [1 + 10.5 \times 10^{-4} (93)] 82.5 = 90.5 \text{ V}$$

This value is too high.

6) DEFINITIVE CHOICE

1.5 KE 68CP :

$$V_{BR \text{ max}} = 74.8 \text{ V, } V_{RM} = 58.1 \text{ V} > 14.4 \text{ V}$$

$$V_{CL} (118^\circ\text{C}) = 1.098 \times 74.8 = 82.5 \text{ V}$$

\Rightarrow 1.5 KE 68CP is suitable.

Figure 5 : Schematic of the Example

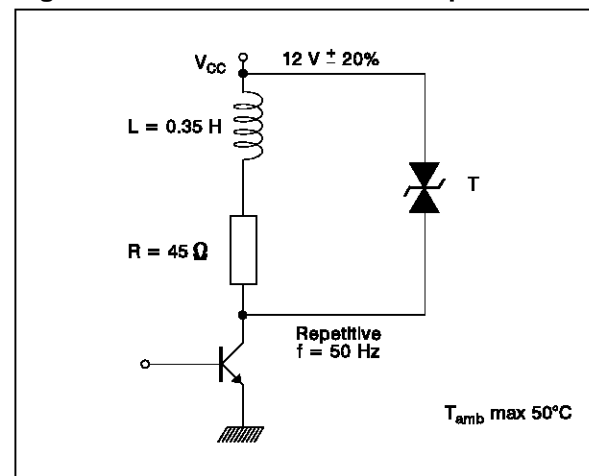

Information furnished is believed to be accurate and reliable. However, SGS-THOMSON Microelectronics assumes no responsibility for the consequences of use of such information nor for any infringement of patents or other rights of third parties which may result from its use. No license is granted by implication or otherwise under any patent or patent rights of SGS-THOMSON Microelectronics. Specifications mentioned in this publication are subject to change without notice. This publication supersedes and replaces all information previously supplied.

SGS-THOMSON Microelectronics products are not authorized for use as critical components in life support devices or systems without express written approval of SGS-THOMSON Microelectronics.

© 1995 SGS-THOMSON Microelectronics - Printed in Italy - All rights reserved.

SGS-THOMSON Microelectronics GROUP OF COMPANIES

Australia - Brazil - France - Germany - Hong Kong - Italy - Japan - Korea - Malaysia - Malta - Morocco
The Netherlands - Singapore - Spain - Sweden - Switzerland - Taiwan - Thailand - United Kingdom - U.S.A.



LittleDiode supplies new, hard to find or obsolete electronic components and semiconductors all over the world.

With over two million different components listed you are sure to find the part you need.

Feel free to visit us today at our online store:

LittleDiode.com

Looking forward to providing you with the best possible service.