

# AN2905FHQ

## Sound input/output interface IC for digital still camera

### ■ Overview

The AN2905FHQ is a sound input/output interface IC which is optimum for incorporation of sound functions in a digital still camera. The sound pre-processing prior to the digital processing and sound post-processing after DAC are integrated on a single chip. This IC is effective to make the equipment compact.

### ■ Features

- Functions required for the sound pre- and post-processings are integrated on a single chip
- The built-in microphone amp. and microphone power supply
- A built-in 0.5 W BTL amp.
- Built-in SP power save and electronic volume functions
- A beep circuit with electronic volume
- A built-in internal microphone amp. on/off function
- A built-in AGC switch
- A built-in AGC to a speaker amp.  
(Prevents the sound distortion, trembling sound and wire breakdown of the speaker at excessively high voltage signal input)

### ■ Applications

- Digital still camera (DSC)

### ■ Application Circuit

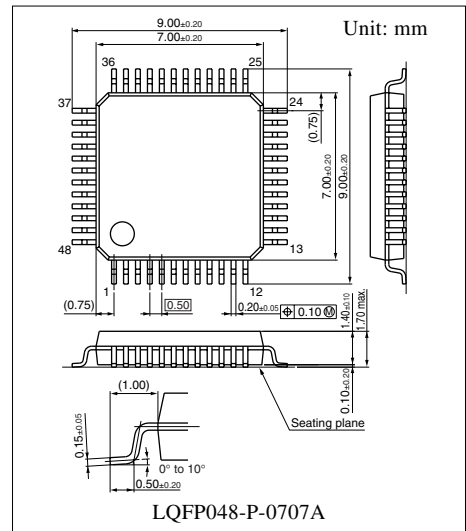
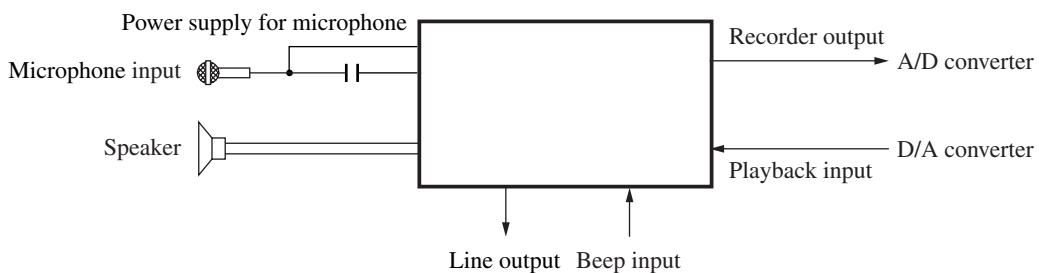

■ Application Circuit Example

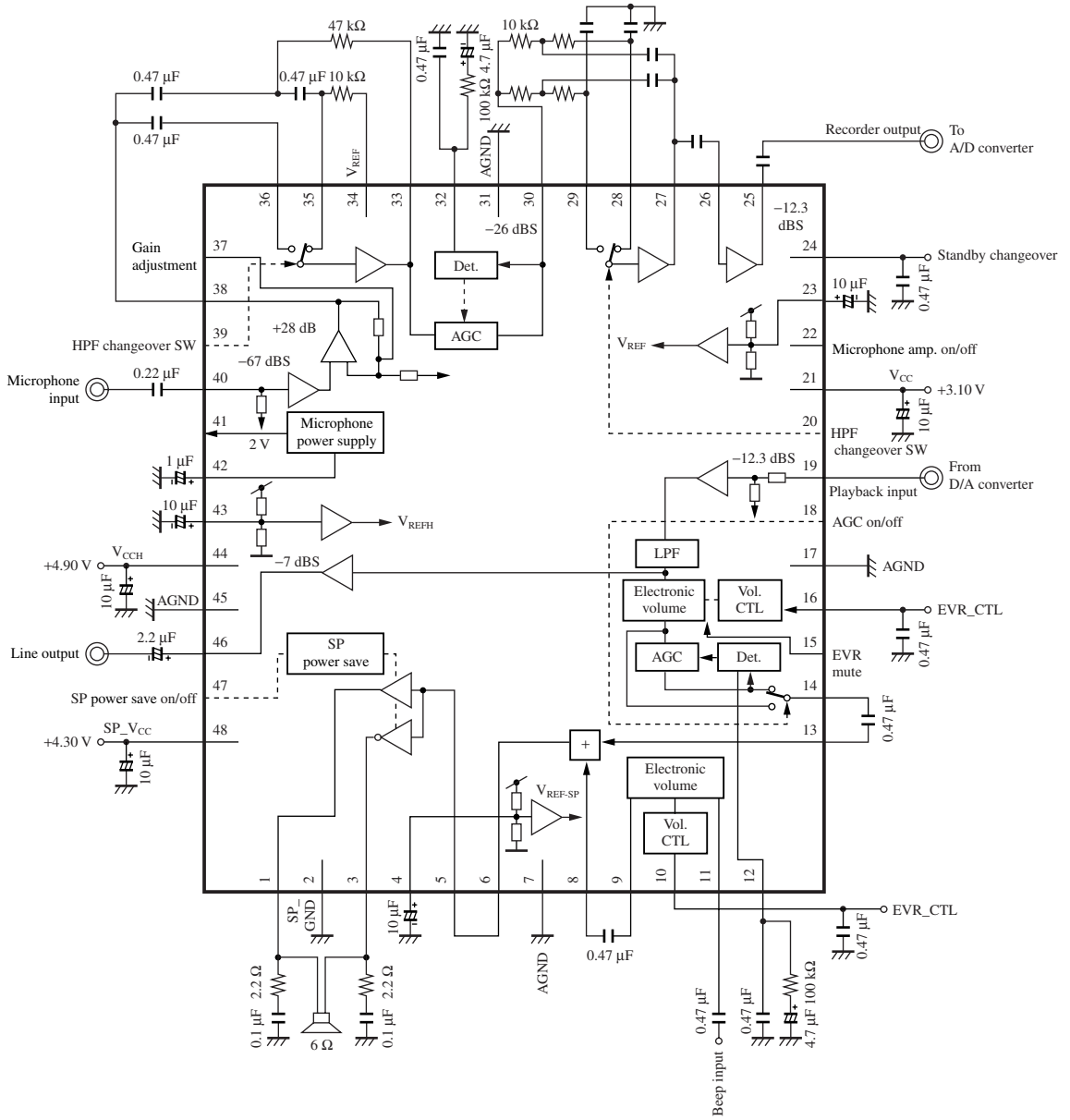

## ■ Pin Descriptions

Pin No.	Description	Pin No.	Description
1	Speaker output (+)	25	Recorder output
2	GND (for SP)	26	HPF operational amp. input
3	Speaker output (-)	27	Operational amp. output
4	$1/2V_{CC-SP}$	28	Operational amp. input
5	Speaker amp. input	29	Operational amp. input
6	Mix. amp. output	30	AGC output
7	GND	31	GND
8	Beep mix. amp. input	32	AGC detection pin
9	Beep electronic volume output	33	Wind noise HPF output
10	Beep electronic volume controll	34	Wind noise HPF bias output
11	Beep input	35	Wind noise HPF operational amp. input
12	Playback-system AGC detection pin	36	Wind noise not through HPF input
13	Mix. amp. input	37	Microphone amp. negative feedback pin
14	Electronic volume output	38	Microphone amp. output
15	EVR mute	39	SW against wind noise
16	Electronic volume control	40	Microphone amp. input
17	GND	41	Microphone power supply
18	AGC changeover SW	42	Microphone power supply smoothing pin
19	Playback input	43	$1/2V_{CCH} (V_{REFH})$
20	HPF changeover SW	44	$V_{CCH}$
21	$V_{CC}$	45	GND
22	Microphone amp. power save SW	46	Line output
23	$1/2V_{CC} (V_{REF})$	47	Speaker power save SW
24	Standby changeover	48	$V_{CC-SP}$ (for speaker drive)

## ■ Absolute Maximum Ratings

Parameter	Symbol	Rating	Unit
Supply voltage *2	$V_{CC}$	3.5	V
	$V_{CCH} / V_{CC-SP}$	5.2	
Supply current	$I_{CC}$	—	A
Power dissipation *3	$P_D$	361	mW
Operating ambient temperature *1	$T_{opr}$	-20 to +70	°C
Storage temperature *1	$T_{stg}$	-55 to +150	°C

Note) \*1: Except for the operating ambient temperature and storage temperature, all ratings are for  $T_a = 25^\circ\text{C}$ .

\*2: When used within the range not exceeding the absolute maximum ratings and the power dissipation.

\*3: The power dissipation shown is for the independent IC without a heat sink at  $T_a = 70^\circ\text{C}$ .

### ■ Recommended Operating Range

Parameter	Symbol	Range	Unit
Supply voltage	$V_{CCH}$	4.50 to 5.00	V
	$V_{CC}$	2.70 to 3.30	
	$V_{CC-SP}$	2.70 to 5.00	

### ■ Electrical Characteristics at $V_{CCH} = 4.9\text{ V}$ , $V_{CC-SP} = 4.3\text{ V}$ , $V_{CC} = 3.1\text{ V}$ , $T_a = 25^\circ\text{C}$

Parameter	Symbol	Conditions	Min	Typ	Max	Unit
<b>Circuit current</b>						
Circuit current without signal (1A) ( $V_{CC}$ -system)	$I_{VCCA}$	Without signal	2.2	3.2	4.2	mA
Circuit current without signal (2A) ( $V_{CCH}$ -system)	$I_{VCHHA}$	Without signal	2.8	3.8	4.8	mA
Circuit current without signal (3A) ( $V_{CC-SP}$ -system)	$I_{VCCSA}$	Without signal	1.0	3.0	6.0	mA
Circuit current without signal (1B) ( $V_{CC}$ -system)	$I_{VCCB}$	I/O power save	—	0.5	1.5	mA
Circuit current without signal (2B) ( $V_{CCH}$ -system)	$I_{VCHHB}$	I/O power save	—	1.8	2.8	mA
Circuit current without signal (3B) ( $V_{CC-SP}$ -system)	$I_{VCCSB}$	SP power save	—	0.7	1.7	mA
Circuit current without signal (3C) ( $V_{CCH}$ -system)	$I_{VCHHC}$	SP power save	—	3.0	4.0	mA
Circuit current without signal (3D) ( $V_{CCH}$ -system)	$I_{VCHHD}$	SP, I/O power save	—	1.8	2.8	mA
Circuit current without signal (1C) ( $V_{CC}$ -system)	$I_{VCCC}$	Microphone amp. off	—	1.8	2.8	mA
<b>Power supply for microphone</b>						
Microphone supply voltage	$V_{MIC}$	Output current = -5 mA	1.8	2.0	2.2	V
<b>Microphone amp. characteristics: Microphone amp. input → Microphone amp. output</b>						
Output level	$V_{ROM}$	$V_{IN} = -37\text{ dBFS}$ , 1 kHz	-9	-8	-7	dBFS
Output THD 1	$TH_{ROM1}$	$V_{IN} = -37\text{ dBFS}$ , 1 kHz, up to 5th harmonic	—	0.02	0.10	%
Output noise	$N_{ROM}$	Without input, using A-curve filter	—	-89	-84	dBFS
Output THD 2	$TH_{ROM2}$	$V_{IN} = -33\text{ dBFS}$ , 1 kHz, up to 5th harmonic	—	0.02	1.0	%
<b>Rec. AGC characteristics: AGC input → Rec. input</b>						
Rec. reference output level A	$V_{ROA}$	$V_{IN} = -38\text{ dBFS}$ , 1 kHz	-13.3	-12.3	-11.3	dBFS
Rec. reference output THD 1A	$TH_{ROA}$	$V_{IN} = -38\text{ dBFS}$ , 1 kHz, up to 5th harmonic	—	0.01	0.10	%
Rec. output noise voltage A	$VN_{ROA}$	Without input, using A-curve filter	—	-81	-75	dBFS

**■ Electrical Characteristics at  $V_{CCH} = 4.9\text{ V}$ ,  $V_{CC-SP} = 4.3\text{ V}$ ,  $V_{CC} = 3.1\text{ V}$ ,  $T_a = 25^\circ\text{C}$  (continued)**

Parameter	Symbol	Conditions	Min	Typ	Max	Unit
<b>Rec. AGC characteristics (continued): AGC input → Rec. input</b>						
Microphone AGC characteristics 1	$V_{AGCML1}$	$V_{IN} = -33\text{ dBFS}$ , 1 kHz	-9.3	-7.3	-5.3	dBFS
Microphone AGC characteristics 2	$V_{AGCML2}$	$V_{IN} = -28\text{ dBFS}$ , 1 kHz	-9.0	-6.0	-3.0	dBFS
Microphone AGC characteristics 3	$V_{AGCML3}$	$V_{IN} = -22\text{ dBFS}$ , 1 kHz	-8.8	-5.8	-2.8	dBFS
Microphone AGC characteristics 3 THD	$TH_{AGCM3}$	$V_{IN} = -22\text{ dBFS}$ , 1 kHz, up to 5th harmonic, load = 22 k $\Omega$	—	0.10	0.40	%
Microphone AGC characteristics 4	$V_{AGCM4}$	$V_{IN} = -4\text{ dBFS}$ , 1 kHz	-8.0	-5.0	-2.0	dBV
Microphone AGC characteristics 4 THD	$TH_{AGCM4}$	$V_{IN} = -4\text{ dBFS}$ , 1 kHz, up to 5th harmonic, load = 22 k $\Omega$	—	0.15	1.0	%
AGC-DC offset voltage	$VD_{ROM}$	Without input, difference from $V_{REF}$ voltage	-30	0	30	mV
<b>PB line output characteristics: PB input → Line output</b>						
Line reference output level at playback	$V_{LOPS}$	$V_{IN} = -12.3\text{ dBFS}$ , 1 kHz	-8.0	-7.0	-6.0	dBFS
Line reference output THD at playback	$TH_{LOPS}$	$V_{IN} = -12.3\text{ dBFS}$ , 1 kHz, up to 5th harmonic	—	0.02	0.10	%
Line reference output noise voltage at playback	$VN_{OPS}$	Without input, using A-curve filter	—	-84	-78	dBFS
Line maximum output level at playback	$V_{LMAPOS}$	f = 1 kHz, load = 22 k $\Omega$ , THD = 1% (up to 5th)	2.8	6.3	—	dBFS
Line crosstalk Mic. input → Line output	$V_{SOPS1}$	$V_{IN} = -61\text{ dBV}$ , f = 1 kHz, using A-curve filter at PB	—	-83	-78	dBFS
Rec. crosstalk 1 PB input → Rec. output	$V_{NOM}$	$V_{IN} = -7.3\text{ dBV}$ , f = 1 kHz, using A-curve filter	—	-81	-73	dBFS
<b>Electronic volume characteristics: PB input → EVR output (AGC = off)</b>						
Electronic volume maximum (+10 dB) gain	$VE_{VMA}$	$V_{IN} = -12.3\text{ dBFS}$ , 1 kHz, vol. = max. ( $V_{16} = 3.1\text{ V}$ )	-12.0	-11.0	-10.0	dBFS
Electronic volume typical (0 dB) gain	$VE_{VTP}$	$V_{IN} = -12.3\text{ dBFS}$ , 1 kHz, vol. = center ( $V_{16} = 1.55\text{ V}$ )	-24.0	-21.0	-18.0	dBFS
Electronic volume minimum (maximum attenuation) gain	$VE_{VMI}$	$V_{IN} = -12.3\text{ dBFS}$ , 1 kHz, vol. = min. ( $V_{16} = 0\text{ V}$ ), using A-curve filter	—	-90	-80	dBFS
<b>Playback-system characteristics (at AGC on)</b>						
Playback AGC characteristics 1	$VPB_{AGC1}$	$V_{IN} = -22.3\text{ dBFS}$ , 1 kHz, vol. = max.	-20	-18	-16	dBFS
Playback AGC characteristics 2 (reference +10 dB)	$VPB_{AGC2}$	$V_{IN} = -12.3\text{ dBFS}$ , 1 kHz, vol. = max.	-12.5	-9.5	-6.5	dBFS
Playback AGC characteristics 3 (reference +22.3 dB)	$VPB_{AGC3}$	$V_{IN} = 0\text{ dBFS}$ , 1 kHz, vol. = max.	-11.5	-8.5	-5.5	dBFS
Playback AGC characteristics 3 (reference +22.3 dB) THD	$THPB_{AGC3}$	$V_{IN} = 0\text{ dBFS}$ , 1 kHz, vol. = max., 5th harmonic	—	0.85	1.0	%

**■ Electrical Characteristics at  $V_{CCH} = 4.9\text{ V}$ ,  $V_{CC-SP} = 4.3\text{ V}$ ,  $V_{CC} = 3.1\text{ V}$ ,  $T_a = 25^\circ\text{C}$  (continued)**

Parameter	Symbol	Conditions	Min	Typ	Max	Unit
<b>Speaker output-system characteristics 1 (at AGC off)</b>						
SP reference output level at playback	$V_{SPPS}$	$V_{IN} = -14.3\text{ dBFS}$ , 1 kHz, vol. = max., beep EVR = min., $R_L = 6\ \Omega$	0.0	1.5	3.0	dBFS
SP reference output THD at playback	$TH_{SPPS}$	$V_{IN} = -14.3\text{ dBFS}$ , 1 kHz, vol. = max., beep EVR = min., $R_L = 6\ \Omega$	—	0.2	0.9	%
SP reference output noise voltage at playback	$VN_{SPPS}$	Without input, using A-curve filter, vol. = typ., beep EVR = min., $R_L = 6\ \Omega$	—	-78	-74	dBFS
SP maximum rating output at playback	$V_{MSPPS}$	$f = 1\text{ kHz}$ , vol. = max., beep EVR = min., $R_L = 6\ \Omega$ , THD = 10%	300	500	—	mW
SP output at power save and playback	$V_{PSPPS}$	$V_{IN} = -14.3\text{ dBFS}$ , 1 kHz, vol. = max., using A-curve filter, $R_L = 6\ \Omega$	—	-110	-90	dBFS
Beep EVR characteristics 1 (at EVR = max.)	$V_{BMA}$	$V_{IN} = -15\text{ dBFS}$ , 1 kHz, vol. = min., $R_L = 6\ \Omega$	0.0	1.5	3.0	dBFS
Beep EVR characteristics 2 (at EVR = min.)	$V_{BMI}$	$V_{IN} = -15\text{ dBFS}$ , 1 kHz, vol. = min., using A-curve filter, $R_L = 6\ \Omega$	—	-72	-67	dBFS
<b>Speaker output-system characteristics 2 (at AGC on)</b>						
SP reference output level at playback	$V_{SPPS}$	$V_{IN} = -12.3\text{ dBFS}$ , 1 kHz, vol. = max., beep EVR = min., $R_L = 6\ \Omega$	2.0	5.0	6.5	dBFS
SP reference output THD at playback	$TH_{SPPS}$	$V_{IN} = -12.3\text{ dBFS}$ , 1 kHz, vol. = max., beep EVR = min., $R_L = 6\ \Omega$	—	0.2	0.9	%
SP reference output noise voltage at playback	$VN_{SPPS}$	Without input, using A-curve filter, vol. = typ., beep EVR = min., $R_L = 6\ \Omega$	—	-72	-68	dBFS
<b>Mode selection hold voltage</b>						
HPF off hold voltage	$V_{39L}$		0.0	—	0.5	V
HPF on hold voltage	$V_{39H}$		2.5	—	3.1	V
SP output on hold voltage	$V_{47L}$		0.0	—	0.5	V
SP output off hold voltage	$V_{47H}$		2.6	—	4.3	V
Standby on hold time	$V_{24L}$		0.0	—	0.5	V
Standby off hold time	$V_{24H}$		2.6	—	3.1	V
Microphone amp. on hold time	$V_{22H}$		0.0	—	0.5	V
Microphone amp. off hold time	$V_{22L}$		2.6	—	3.1	V
HPF on hold voltage	$V_{20L}$		0.0	—	0.5	V
HPF off hold voltage	$V_{20H}$		2.6	—	3.1	V
AGC on hold voltage	$V_{18L}$		0.0	—	0.5	V
AGC off hold voltage	$V_{18H}$		2.6	—	3.1	V
EVR mute on hold voltage	$V_{15L}$		0.0	—	0.5	V
EVR mute off hold voltage	$V_{15H}$		2.6	—	3.1	V

■ Technical Data

1.  $P_D - T_a$  curves of LQFP048-P-0707A

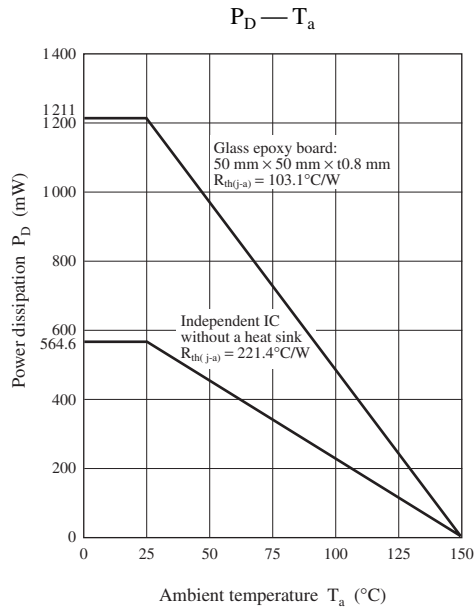

■ Technical Data (continued)

2. Main Characteristics

Electronic volume control curve

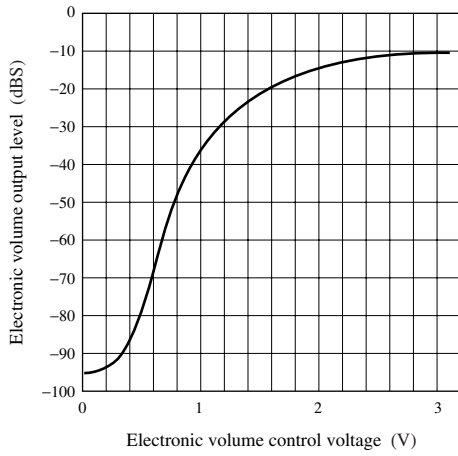

Microphone amp. gain —  
External resistor between pin 37 and pin 38

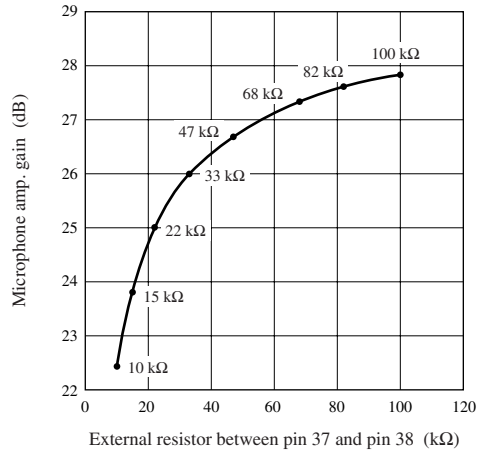

Maximum power consumption — Supply voltage  $V_{CC-SP}$

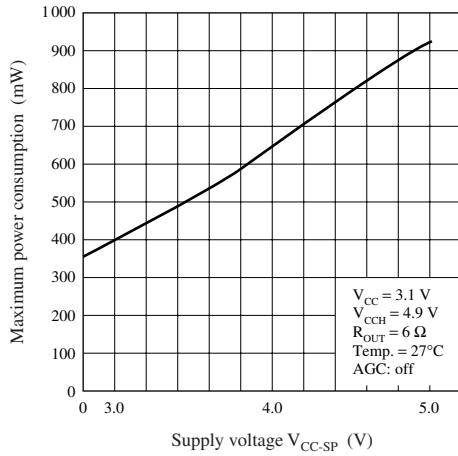

## Request for your special attention and precautions in using the technical information and semiconductors described in this material

- (1) An export permit needs to be obtained from the competent authorities of the Japanese Government if any of the products or technologies described in this material and controlled under the "Foreign Exchange and Foreign Trade Law" is to be exported or taken out of Japan.
- (2) The technical information described in this material is limited to showing representative characteristics and applied circuit examples of the products. It does not constitute the warranting of industrial property, the granting of relative rights, or the granting of any license.
- (3) The products described in this material are intended to be used for standard applications or general electronic equipment (such as office equipment, communications equipment, measuring instruments and household appliances).  
Consult our sales staff in advance for information on the following applications:
  - Special applications (such as for airplanes, aerospace, automobiles, traffic control equipment, combustion equipment, life support systems and safety devices) in which exceptional quality and reliability are required, or if the failure or malfunction of the products may directly jeopardize life or harm the human body.
  - Any applications other than the standard applications intended.
- (4) The products and product specifications described in this material are subject to change without notice for reasons of modification and/or improvement. At the final stage of your design, purchasing, or use of the products, therefore, ask for the most up-to-date Product Standards in advance to make sure that the latest specifications satisfy your requirements.
- (5) When designing your equipment, comply with the guaranteed values, in particular those of maximum rating, the range of operating power supply voltage and heat radiation characteristics. Otherwise, we will not be liable for any defect which may arise later in your equipment.  
Even when the products are used within the guaranteed values, redundant design is recommended, so that such equipment may not violate relevant laws or regulations because of the function of our products.
- (6) When using products for which dry packing is required, observe the conditions (including shelf life and after-unpacking standby time) agreed upon when specification sheets are individually exchanged.
- (7) No part of this material may be reprinted or reproduced by any means without written permission from our company.

## Please read the following notes before using the datasheets

- A. These materials are intended as a reference to assist customers with the selection of Panasonic semiconductor products best suited to their applications.  
Due to modification or other reasons, any information contained in this material, such as available product types, technical data, and so on, is subject to change without notice.  
Customers are advised to contact our semiconductor sales office and obtain the latest information before starting precise technical research and/or purchasing activities.
- B. Panasonic is endeavoring to continually improve the quality and reliability of these materials but there is always the possibility that further rectifications will be required in the future. Therefore, Panasonic will not assume any liability for any damages arising from any errors etc. that may appear in this material.
- C. These materials are solely intended for a customer's individual use.  
Therefore, without the prior written approval of Panasonic, any other use such as reproducing, selling, or distributing this material to a third party, via the Internet or in any other way, is prohibited.



LittleDiode supplies new, hard to find or obsolete electronic components and semiconductors all over the world.

With over two million different components listed you are sure to find the part you need.

Feel free to visit us today at our online store:

[LittleDiode.com](http://LittleDiode.com)

Looking forward to providing you with the best possible service.