Application Note

Precision Temperature Measurement using RTDs (Resistance Temperature Detectors) with the CS5516 and CS5520 Bridge Transducer A/D Converters

by
Jerome Johnston

The CS5516/CS5520 bridge-measurement A/D converters can be configured for precise measurement of resistance using a ratiometric resistance measurement technique.

DC-Excited RTD Digitizer

Figure 1 illustrates the CS5516 16-bit A/D converter used as a digitizer for a platinum RTD. The RTD is excited with a 250 μ A current generated by the LM334 programmable current source. The 1N457 diode offers some first order temperature compensation to the current source, but the exact value and temperature coefficient of the current source isn't important because the current is used in a ratiometric measurement configuration.

The current is used to develop both the voltage reference (2.5 V across R1) for the A/D and the signal voltage across the RTD. The initial accuracy of the reference resistor is not critical because the CS5516 offers gain calibration capability, but reference resistor R1 must have low temperature coefficient. The temperature drift of the reference resistor will affect the accuracy of the ratiometric measurement. A Vishay S102K resistor is recommended for the

reference resistor to achieve optimal measurement accuracy.

The offset and gain accuracy of the circuit are ensured by self-calibration. Offset is calibrated with 0 Ω connected in place of the RTD. Full scale is then calibrated with a known resistance whose value is ideally 400.00 Ω connected in place of the RTD. Once the A/D is calibrated, the RTD resistance is measured as a proportion of the 400 Ω . The range of resistance which can be measured is 0-400 Ω . This range represents a temperature range of below -200 $^{\circ}$ C to greater than +800 $^{\circ}$ C when using a 100 Ω platinum RTD. The resistance over the 400 Ω span can be measured to an accuracy better than 0.025 Ω . Linearization of the RTD and resistance-to-temperature conversion is then performed in the system microcontroller. Accuracy of the temperature measurement will depend on the RTD and its associated linearization algorithm.

AC-Excited RTD Digitizer

Synchronous detection techniques can greatly enhance measurement accuracy. In a synchronous detection system, the sensor is excited with a fixed frequency square wave. The

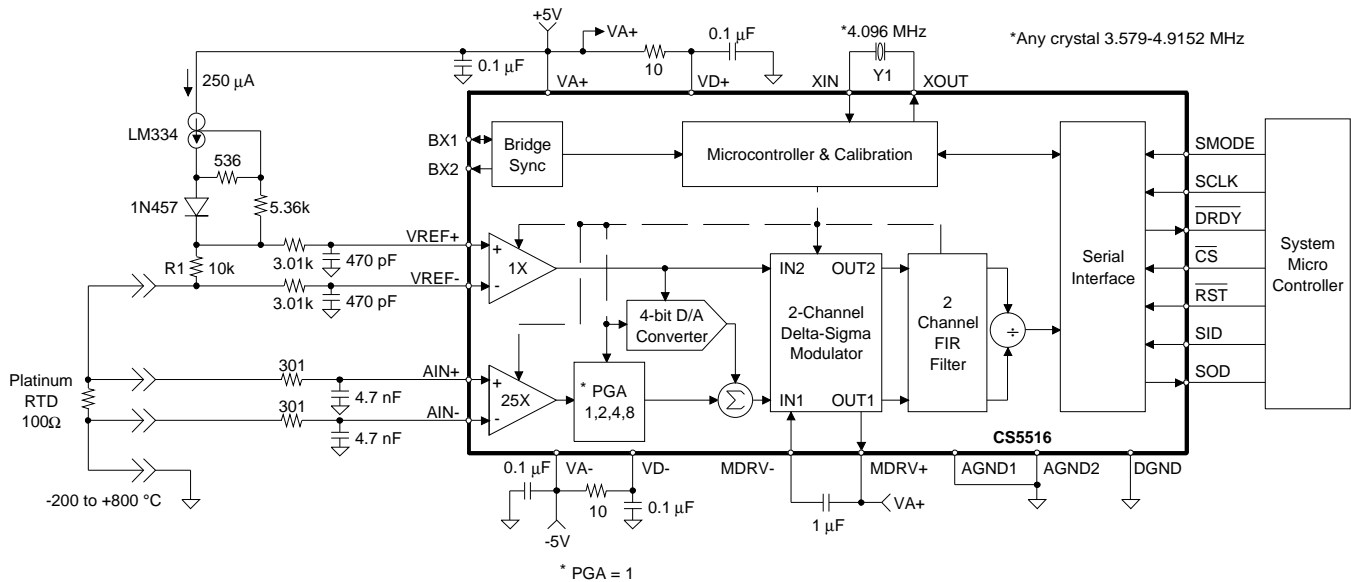

Figure 1. CS5516/20 RTD Digitizer - DC Excitation

detection system measures only the information which is of the same phase and frequency as the excitation frequency. This measurement method eliminates the dc errors introduced by parasitic thermocouples which lie between the sensor and the detection circuitry.

Figure 2 illustrates an RTD measurement system in which the RTD is excited with a switched-polarity current source. Resistor values are illustrated for two different current options. Less self-heating of the RTD occurs with lower excitation current. The majority of RTD measurement systems use a 1 mA direct current (dc) for excitation. The 1 mA current is chosen to produce a large enough output signal so that parasitic thermocouple errors are not a significant portion of the signal to be measured, but parasitic thermocouples will limit accuracy. The proposed ac-excited RTD digitizer uses only 100 μA excitation current. Using a 100 μA current for excitation will result in an output signal only one tenth of that produced by a 1 mA excitation but the self-heating effects of the RTD will be one hundred times less. Less signal

output from the RTD is acceptable when synchronous detection is used because error voltages due to parasitic thermocouples are of no consequence.

The switched-polarity dc current source is developed by operational amplifiers U1A and U1B. The CS5520 is configured for internally-controlled AC excitation. The CS5520 is programmed to output a 1kHz square wave (XIN = 4.096 MHz) from its BX2 pin. Capacitor C1 is used to convert the output signal from 0-5 V logic to ±2.5 volts, which is then converted by the voltage-to-current converter to output either ±100 μA or ±400 μA depending upon the selection of resistors. The switched-polarity excitation current is then used to develop the reference voltage for the converter across resistor R7 and used to excite the RTD. A four wire Kelvin-connected RTD is used to maximize measurement accuracy. Reference resistor R7 will set the gain stability of the measurement and therefore a Vishay-type S102K series resistor is highly recommended.

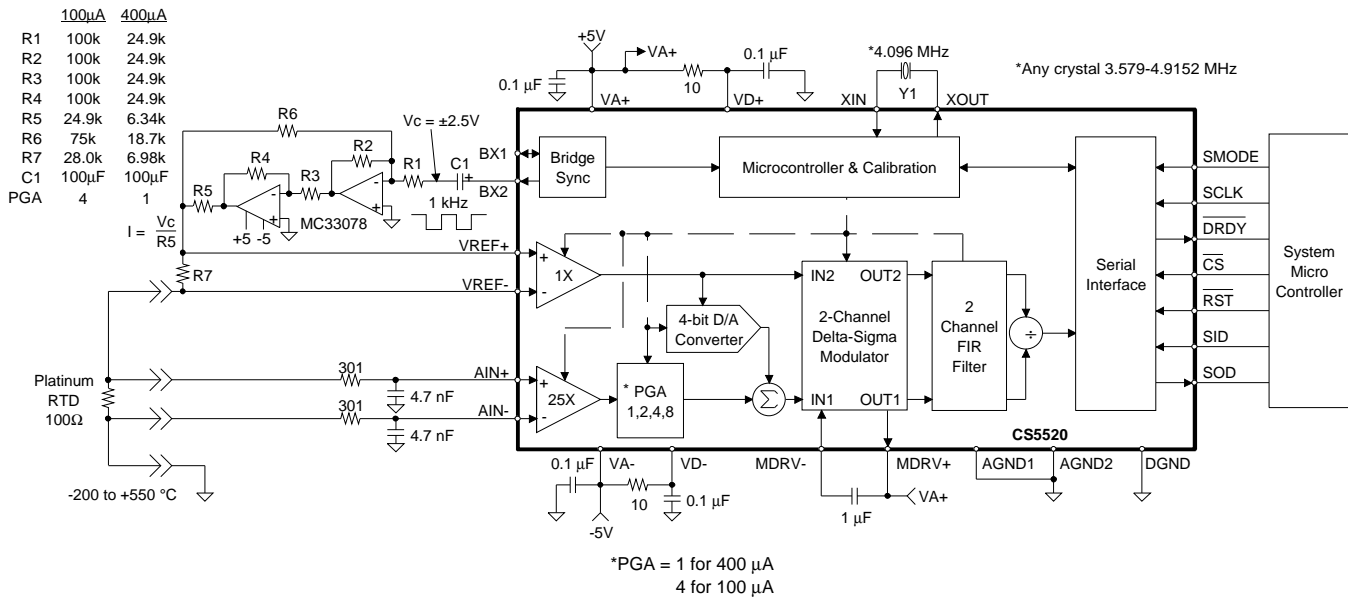

Figure 2. CS5516/20 RTD Digitizer - AC Excitation

Note that the values indicated for the R7 reference resistor are the nominal suggested values. The converter has gain calibration capability capable of adjusting gain for gain spans $\pm 20\%$ of nominal. Therefore resistor R7 could be changed up to $\pm 15\%$ of its stated value and still leave 5% of the gain calibration range capability available. For example, R7 could be set to 30 K (100 µA) or to 7.5 K (400 µA) to utilize more acceptable precision resistor values. The initial accuracy of R7 is not that important if gain calibration is used. Stability over temperature is the most important parameter for R7.

Resistors of 1% tolerance and 100 ppm tempco can be used in the voltage-to-current converter and not affect system accuracy. The resistance measurement is performed using ratiometric techniques, therefore the exact value of the drive current is not critical. Wirewound resistors should not be used in the switched-polarity current generator or for resistor R7.

When using 100 µA excitation, the PGA (Programmable Gain Amplifier) inside the CS5520 is set to a gain of 4. The internal instrumentation amplifier is fixed at 25; therefore the input span is nominally set to 28 mV ($(100 \mu\text{A} \times 28.0 \text{ k}) / (4 \times 25) = 28 \text{ mV}$). The zero of the transfer function can be calibrated using a zero ohm resistor in place of the RTD. Gain calibration can be performed using a 300Ω resistor in place of the RTD. The resistance span will support temperature measurement over a temperature range of -200 °C to +550 °C. If higher temperatures need to be measured, that is, higher resistance than 300Ω, the gain calibration can be performed using a 600Ω resistor with the PGA set to a gain of 2.

Linearization of the RTD and resistance-to-temperature conversion is performed in the system microcontroller. Accuracy of the temperature measurement will depend on the RTD and its associated linearization algorithm.

• **Notes** •



LittleDiode supplies new, hard to find or obsolete electronic components and semiconductors all over the world.

With over two million different components listed you are sure to find the part you need.

Feel free to visit us today at our online store:

LittleDiode.com

Looking forward to providing you with the best possible service.