

SHORT CIRCUIT PROTECTION ON L6203

By G. SCROCCHI and G. FUSAROLI

With devices like L6203 used as driver often interfacing the external world by means of wires, can be easy to have short circuits.

A short circuit can occur for many reasons : a short on the load, a mistake during the connection of the wires between the device and the load (i.e. L6203 driving a motor), an accidental short between the wires and so on.

The outputs of L6203 are not protected against the short circuit and if a short occurs, the big amount of current flowing through the outputs can destroy the device.

To avoid this risk can be useful to add a circuitry to protect the device : in this case, to have a total protection, we must consider three types of short circuit :

- 1 - output to output short circuit
- 2 - output to supply voltage short circuit
- 3 - output to ground short circuit

The first step is to sense the short circuit current. In output to output (fig 1) or output to supply (fig 2) short circuit can be used the sensing resistor (R_{SL}) already used to set the current flowing in the load during the normal operation.

Figure 1.

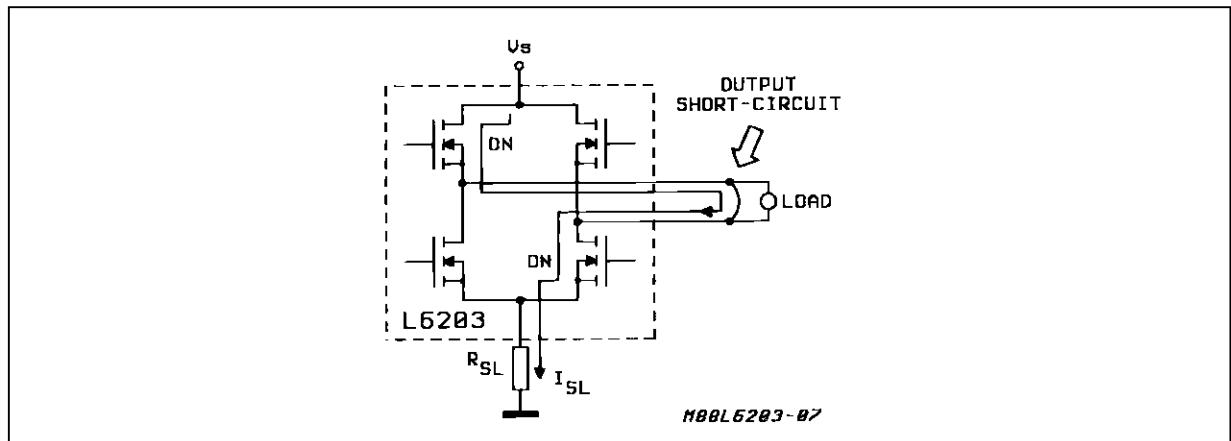
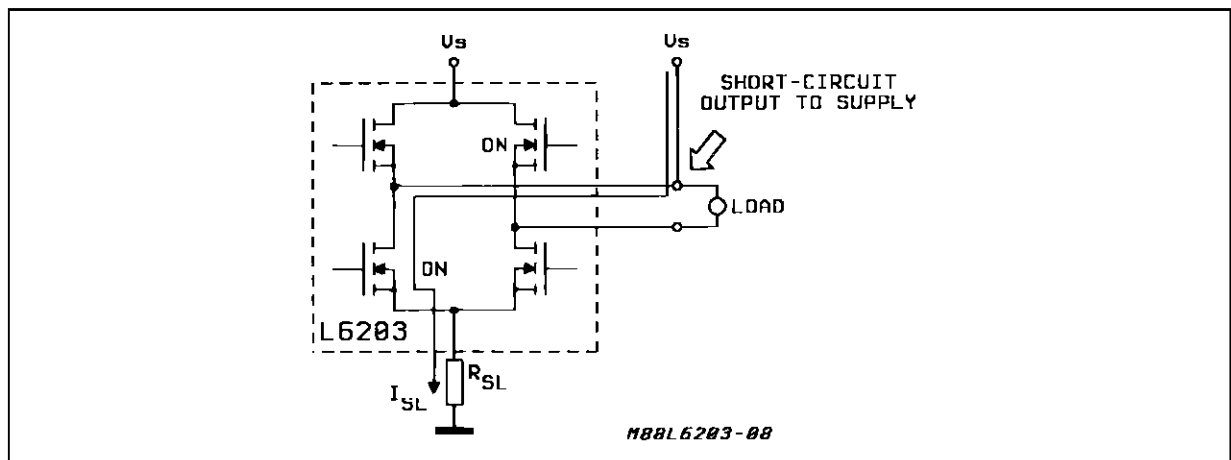

Figure 2.



APPLICATION NOTE

To sense the output to ground short circuit (fig 3) another sensing resistor (R_{SU}) must be added between the supply pin and the supply voltage.

Figure 3.

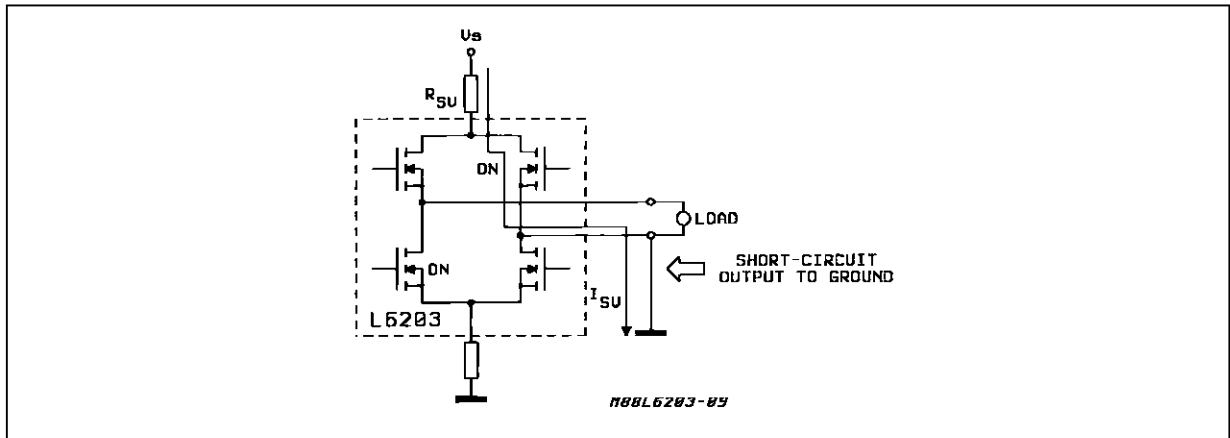

The second step is to create a threshold over which the value of the current must be considered as short circuit : for this way a transistor or a diode could be used.

The complete protection will be given by the ' or ' of

the signal coming from the upper and the lower sensing circuitry ; this signal can be used to act on the ENABLE pin of the L6203 disabling the output stages. A complete protection schematic diagram is shown in fig. 4.

Figure 4.

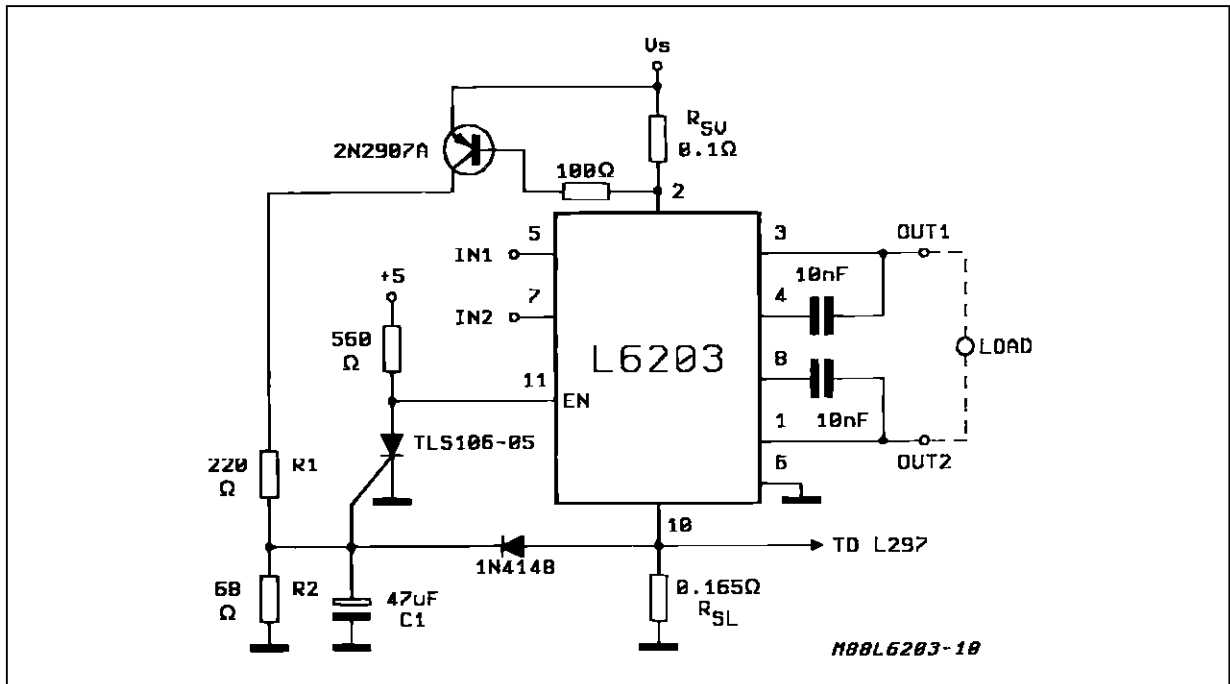

In normal operation the circuit works up to 3A/40V. When a short circuit occurs the SCR is triggered and L6203 disabled : due to the SCR memory L6203 is kept disabled until the power is switched off and then on, if the cause of short was removed.

The short circuit is detected when :

$$I_{SU} > \frac{V_{BE(T1)}}{R_{SU}} = \frac{0.6}{0.1} = 6A$$

$$I_{SL} > \frac{V_D + V_{THSCMT}}{R_{SC}} = \frac{0.6 + 0.7}{0.165} = 7.8A$$

The effective short circuit peak current is greater than I_{SU} and I_{SL} : this is due to the high dI/dT during the short and to the delay between the short circuit detection and the ENABLE intervention :

R_{SU} and R_{SL} must be non inductive resistors.

R_1 and R_2 are used to scale the signal when the transistor goes on and in conjunction with C_1 to filter the short circuit signals in order to avoid false trigger of the SCR : this filtering should not be too much heavy to avoid to introduce an excessive delay in the short circuit loop.

I_{SU} and I_{SL} must be calculated at the effective operating temperature being the V_{be} and V_d temperature dependent.

Instead of the SCR, a monostable with a long time constant (0.3 ÷ 0.5 sec) can be used : in the case, every time a short circuit occurs, L6203 is disabled for the monostable time constant and then enabled, if the short is still present L6203 is disabled again, if the short was removed L6203 returns in normal operation (fig 5).

Figure 5.

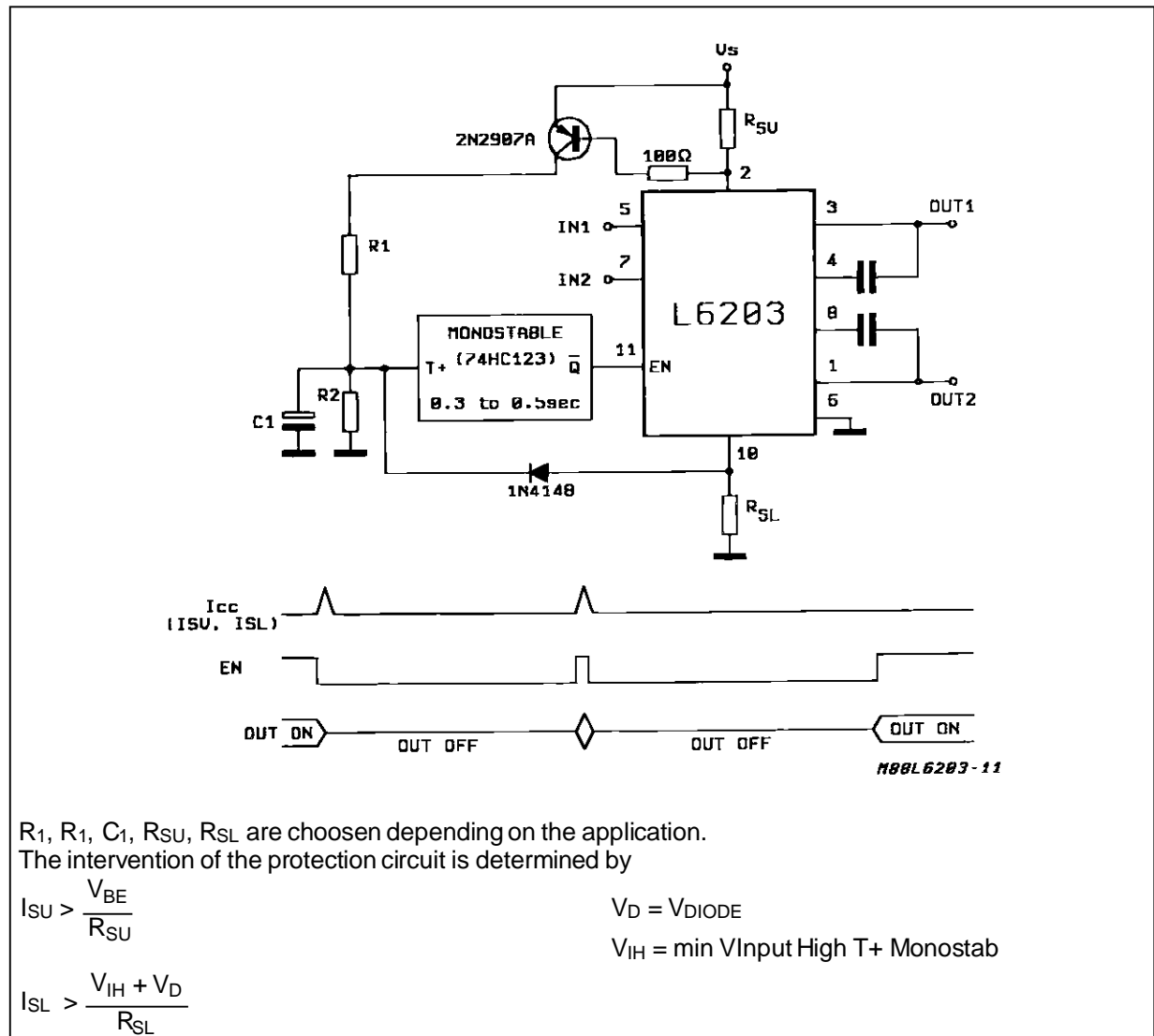

R_1 , R_2 , C_1 , R_{SU} , R_{SL} are chosen depending on the application. The intervention of the protection circuit is determined by

$$I_{SU} > \frac{V_{BE}}{R_{SU}}$$

$$V_D = V_{DIODE}$$

$$I_{SL} > \frac{V_{IH} + V_D}{R_{SL}}$$

$$V_{IH} = \min V_{Input\ High\ T+ \ Monostab}$$

APPLICATION NOTE

Information furnished is believed to be accurate and reliable. However, SGS-THOMSON Microelectronics assumes no responsibility for the consequences of use of such information nor for any infringement of patents or other rights of third parties which may result from its use. No license is granted by implication or otherwise under any patent or patent rights of SGS-THOMSON Microelectronics. Specifications mentioned in this publication are subject to change without notice. This publication supersedes and replaces all information previously supplied. SGS-THOMSON Microelectronics products are not authorized for use as critical components in life support devices or systems without express written approval of SGS-THOMSON Microelectronics.

© 1995 SGS-THOMSON Microelectronics All Rights Reserved

SGS-THOMSON Microelectronics GROUP OF COMPANIES

Australia - Brazil - France - Germany - Hong Kong - Italy - Japan - Korea - Malaysia - Malta - Morocco - The Netherlands - Singapore - Spain - Sweden - Switzerland - Taiwan - Thailand - United Kingdom - U.S.A.



LittleDiode supplies new, hard to find or obsolete electronic components and semiconductors all over the world.

With over two million different components listed you are sure to find the part you need.

Feel free to visit us today at our online store:

LittleDiode.com

Looking forward to providing you with the best possible service.