

AN2601

Head Amplifier Circuit for VHD Video Disc Player

■ Outline

The AN2601 is an integrated circuit with a built-in AGC circuit which amplifies up to 65 dB.

It also has two operation amplifiers; AFT amplifier and operation amplifier.

■ Features

- Head amplifier with 10MHz band width
- -58dB noise level
- 5.5V regulated DC voltage supply

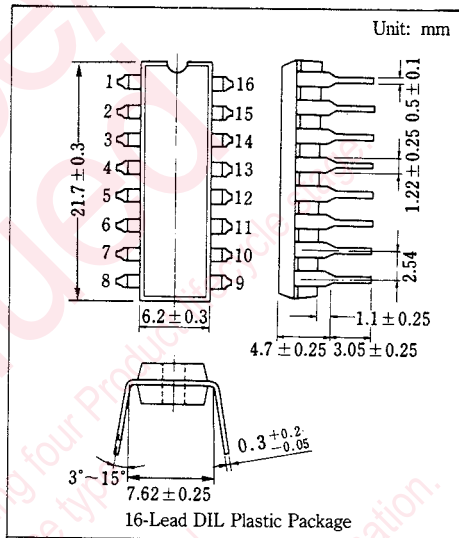

■ Block Diagram

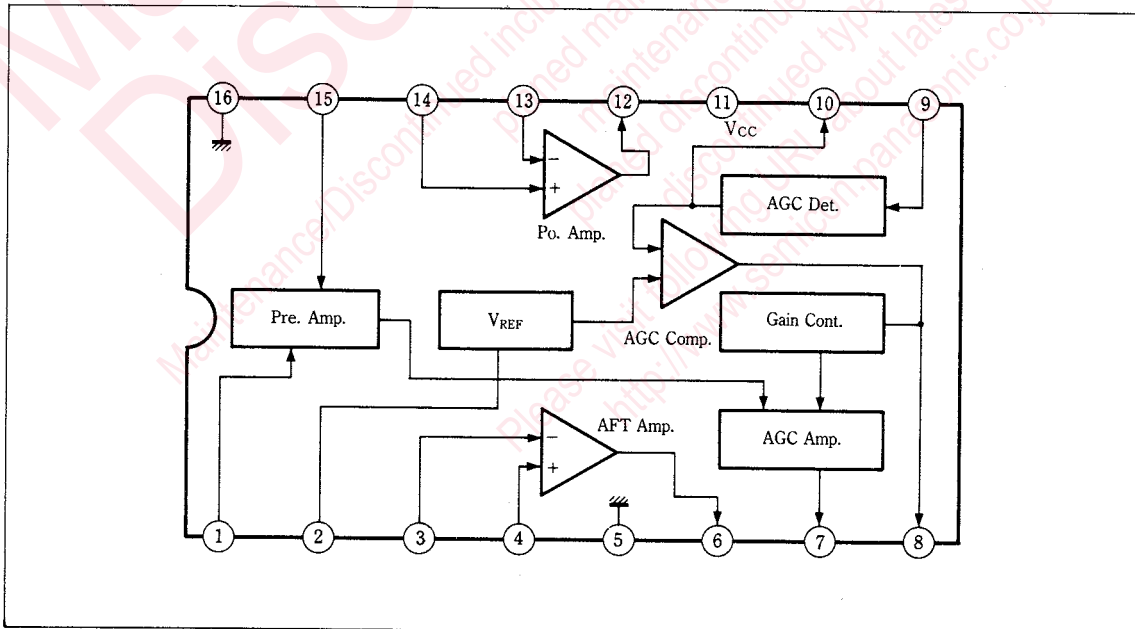

■ Pin

Pin No.	Pin Name	Pin No.	Pin Name
1	Input Pre Amplifier	9	Output AGC Detector
2	Output 5.5V Regulated	10	Input AGC Detector
3	Input AFT Amplifier (-)	11	V _{cc} 12V
4	Input AFT Amplifier (+)	12	Output P _O Amplifier
5	GND 1	13	Input P _O Amplifier (-)
6	Output AFT Amplifier	14	Input P _O Amplifier (+)
7	Output Pre Amplifier	15	Input Bias Voltage of Pre Amplifier
8	Output AGC Level	16	GND 2

■ Absolute Maximum Ratings(T_a = 25°C)

Item	Symbol	Rating	Unit
Supply voltage	V _{CC}	14.4	V
Supply current	I _{CC}	40	mA
Power dissipation	P _D	580	mW
Operating ambient temperature	T _{opr}	-20~+70	°C
Storage temperature	T _{stg}	-55~+150	°C

■ Electrical Characteristics(V_{CC} = 12V, T_a = 25°C)

Item	Symbol	Test Circuit	Condition	min.	typ.	max.	Unit
Total circuit current	I _{tot}		V ₃ , V ₁₄ =0.5V, V _{CC} =12V, V ₄ , V ₁₃ =0.6V	15	22	30	mA
Terminal voltage	V ₂₋₅		V ₃ , V ₁₄ =0.5V, V _{CC} =12V, V ₄ , V ₁₃ =0.6V	5.1	5.5	5.9	V
Frequency characteristic	f _c *1 (10MHz)	1	Pin① 10MHz 1mV _{P-P} , Pin⑧ 0.65V	-3	0	+3	dB
Output harmonic distortion	V _{O(2f)} *2	1	Pin① 7MHz 1mV _{P-P} , Pin⑧ Adj. V _O =400mV _{P-P}		-48	-30	dB
Allowable input distortion	V _{I0(2f)} *3	1	Pin① 7MHz 3mV _{P-P} , Pin⑧ Adj. V _O =200mV _{P-P}		-45	-30	dB
Control sensitivity	β	1	Int. AGC, Pin① 7MHz 1~3mV _{P-P}	13	18	21	mV/dB
AGC level	V _{OA}	1	Int. AGC, Pin① 7MHz 3mV _{P-P}	240	340	440	mV _{P-P}
Noise level	n _O	1	Pin⑧ 0.65V		-65	-58	dBm
AFT open circuit gain	G _{AFT}	2	Pin④ 1kHz, 200μV _{P-P}	80	85		dB
P _O open circuit gain	G _P	2	Pin④ 1kHz, 200μV _{P-P}	80	85		dB
P _O output current	I _{OP}		V ₁₄ =6V, R _L =300Ω	14	20	26	mA

*1 Output voltage ratio, assuming an output voltage as 0 dB in case of 1 MHz, 1 mV_{P-P} input signal 22.

*2 2nd harmonic voltage ratio, assuming 7 MHz, 400 mV_{P-P} output voltage as 0 dB.

*3 2nd harmonic voltage ratio, assuming 7 MHz, 200 mV_{P-P} output voltage as 0 dB.

Test Circuit 1 ($f_{C(10MHz)}$, $V_{O(2\theta)}$, $V_{IO(2\theta)}$, β , V_{OA} , n_O)

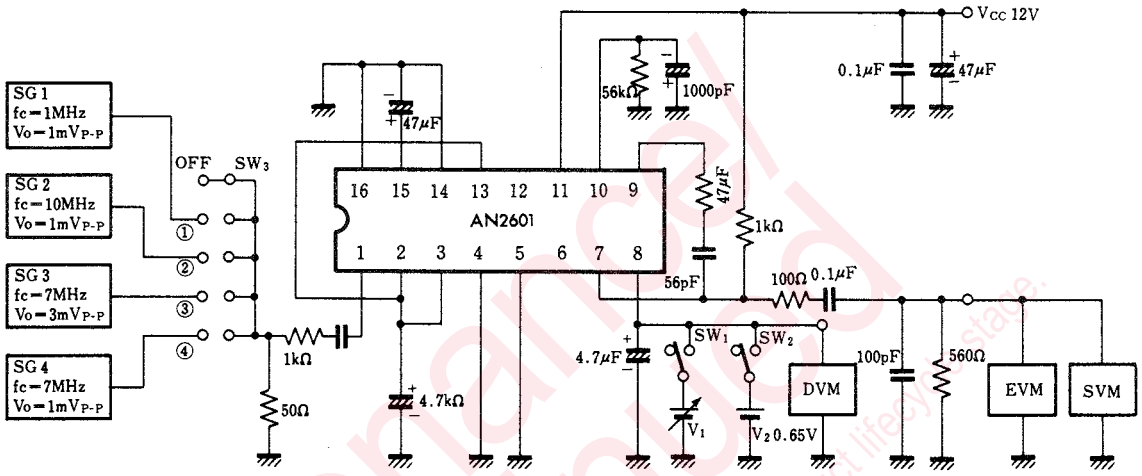

a) Setting of each device

SG1 $f_c = 1\text{MHz}$, $V_O = 1\text{mV}_{P-P}$

SG2 $f_c = 10\text{MHz}$, $V_O = 1\text{mV}_{P-P}$

SG3 $f_c = 7\text{MHz}$, $V_O = 3\text{mV}_{P-P}$

SG4 $f_c = 7\text{MHz}$, $V_O = 1\text{mV}_{P-P}$

$V_{CC} = 12\text{V}$

V_1 ...Variable DC supply voltage

$V_2 = 0.65\text{V}$

Switch Setting

No.	SW1	SW2	SW3	Output Pin
B3	OFF	ON	① and ②	⑦
B4	ON	OFF	4	⑦
B5	ON	OFF	3	⑦
B6	OFF	OFF	③ and ④	⑧
B7	OFF	OFF	④	⑦
B8	OFF	ON	OFF	⑦

b) Testing Methods

● $f_{C(10MHz)}$: Frequency characteristic

Assuming an output voltage as 0 dB when a 1 MHz input signal and a 1 mV_{p-p} signal voltage are applied, and measure an output voltage when setting the input signal and signal voltage to 10 MHz and 1 mV_{p-p}, respectively.

● $V_{O(2\theta)}$: Output harmonic distortion

Adjust V_1 so that an output voltage will be 400 mV_{p-p} when a 7 MHz input signal and 1 mV_{p-p} signal voltage are applied.

Assuming a 7 MHz, 400 mV_{p-p} output signal as 0 dB, measure a level of 14 MHz signal component.

● β : Control sensitivity

Measure a Pin ⑧ DC voltage when a 7 MHz input signal and a 1 mV_{p-p} signal voltage are applied, and when a 7 MHz input signal and a 3 mV_{p-p} signal voltage are applied.

$$\text{Control sensitivity } \beta = (V_1 - V_3) / 9.54$$

V_1 ...DC voltage in case of SG4

V_3 ...DC voltage in case of SG3

$$9.45(\text{dB}) = 20 \log \left[\frac{3(\text{mV}_{P-P})}{1(\text{mV}_{P-P})} \right]$$

● V_{CA} : AGC level

Measure a Pin ⑦ output amplitude when a 7 MHz input signal and a 1 mV_{p-p} signal voltage are applied.

● n_O : Noise level

Measure a noise level up to a frequency band of 10 MHz in a no-input state.

Test Circuit 2 (G_{AFT} , G_P)

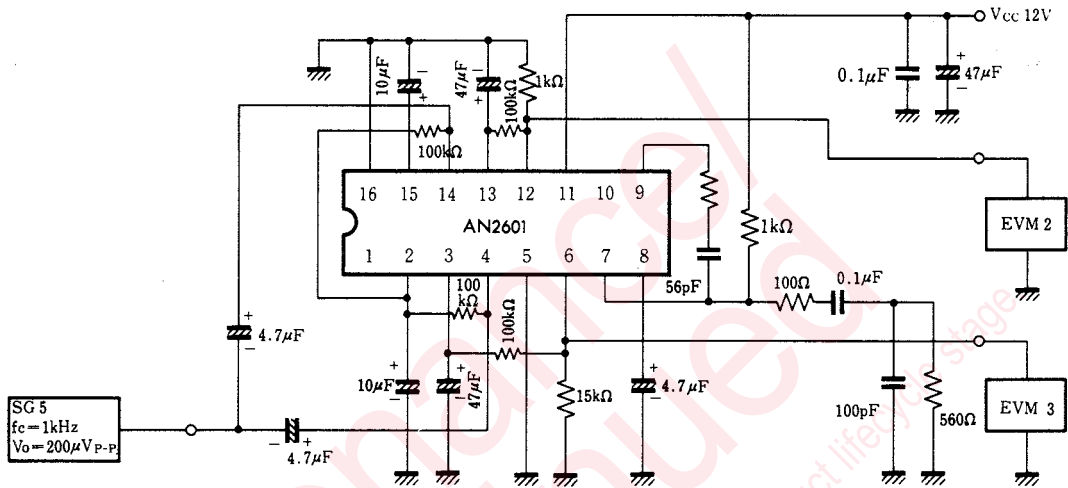

a) Setting of each device

SG5 $f_c = 1\text{kHz}$, $V_o = 200\mu\text{V}_{p-p}$

$V_{CC} = 12\text{V}$

EVM2...Electronic voltmeter

EVM3...Electronic voltmeter

b) Testing method

G_{AFT} : AFT open circuit gain

Measure the Pin ⑥ output voltage when a 1 kHz input signal and a $200\mu\text{V}_{p-p}$ signal voltage are applied.

G_P : P_o open circuit gain

Measure the Pin ⑫ output voltage when a 1 KHz and a $200\mu\text{V}_{p-p}$ signal voltage are applied.

Request for your special attention and precautions in using the technical information and semiconductors described in this book

- (1) If any of the products or technical information described in this book is to be exported or provided to non-residents, the laws and regulations of the exporting country, especially, those with regard to security export control, must be observed.
- (2) The technical information described in this book is intended only to show the main characteristics and application circuit examples of the products. No license is granted in and to any intellectual property right or other right owned by Panasonic Corporation or any other company. Therefore, no responsibility is assumed by our company as to the infringement upon any such right owned by any other company which may arise as a result of the use of technical information described in this book.
- (3) The products described in this book are intended to be used for standard applications or general electronic equipment (such as office equipment, communications equipment, measuring instruments and household appliances).
Consult our sales staff in advance for information on the following applications:
 - Special applications (such as for airplanes, aerospace, automobiles, traffic control equipment, combustion equipment, life support systems and safety devices) in which exceptional quality and reliability are required, or if the failure or malfunction of the products may directly jeopardize life or harm the human body.
 - Any applications other than the standard applications intended.
- (4) The products and product specifications described in this book are subject to change without notice for modification and/or improvement. At the final stage of your design, purchasing, or use of the products, therefore, ask for the most up-to-date Product Standards in advance to make sure that the latest specifications satisfy your requirements.
- (5) When designing your equipment, comply with the range of absolute maximum rating and the guaranteed operating conditions (operating power supply voltage and operating environment etc.). Especially, please be careful not to exceed the range of absolute maximum rating on the transient state, such as power-on, power-off and mode-switching. Otherwise, we will not be liable for any defect which may arise later in your equipment.
 - Even when the products are used within the guaranteed values, take into the consideration of incidence of break down and failure mode, possible to occur to semiconductor products. Measures on the systems such as redundant design, arresting the spread of fire or preventing glitch are recommended in order to prevent physical injury, fire, social damages, for example, by using the products.
- (6) Comply with the instructions for use in order to prevent breakdown and characteristics change due to external factors (ESD, EOS, thermal stress and mechanical stress) at the time of handling, mounting or at customer's process. When using products for which damp-proof packing is required, satisfy the conditions, such as shelf life and the elapsed time since first opening the packages.
- (7) This book may be not reprinted or reproduced whether wholly or partially, without the prior written permission of our company.



LittleDiode supplies new, hard to find or obsolete electronic components and semiconductors all over the world.

With over two million different components listed you are sure to find the part you need.

Feel free to visit us today at our online store:

LittleDiode.com

Looking forward to providing you with the best possible service.