

A DESIGNER'S GUIDE TO THE L200 VOLTAGE REGULATOR

Delivering 2 A at a voltage variable from 2.85 V to 36 V, the L200 voltage regulator is a versatile device that simplifies the design of linear supplies. This design guide describes the operation of the device and its applications.

The introduction of integrated regulator circuits has greatly simplified the work involved in designing supplies. Regulation and protection circuits required for the supply, previously realized using discrete components, are now integrated in a single chip. This had led to significant cost and space saving as well as increased reliability. Today the designer has a wide range of fixed and adjustable, positive and negative series regulators to choose from as well as an increasing number of switching regulators.

The L200 is a positive variable voltage regulator which includes a current limiter and supplies up to 2 A at 2.85 to 36 V.

The output voltage is fixed with two resistors or, if a continuously variable output voltage is required, with one fixed and one variable resistor.

The maximum output current is fixed with a low value resistor. The device has all the characteristics common to normal fixed regulators and these are described in the datasheet. The L200 is particularly suitable for applications requiring output voltage variation or when a voltage not provided by the standard regulators is required or when a special limit must be placed on the output current.

The L200 is available in two packages :

Pentawatt - Offers easy assembly and good reliability. The guaranteed thermal resistance ($R_{th\ j-case}$) is 3 °C/W (typically 2 °C/W) while if the device is used without heatsink we can consider a guaranteed junction-ambient thermal resistance of 50 °C/W.

TO-3 - For professional and military use or where good hermeticity is required.

The guaranteed junction-case thermal resistance is 4 °C/W, while the junction-ambient thermal resistance is 35 °C/W.

The junction-case thermal resistance of this package, which is greater than that of the Pentawatt, is

partly compensated by the lower contact resistance with the heatsink, especially when an electrical insulator is used.

CIRCUIT OPERATION

As can be seen from the block diagram (fig. 1) the voltage regulation loop is almost identical to that of fixed regulators. The only difference is that the negative feedback network is external, so it can be varied (fig. 3). The output is linked to the reference by :

$$V_{out} = V_{ref} \left(1 + \frac{R2}{R1} \right) \quad (1)$$

Considering V_{out} as the output of an operational amplifier with gain equal to $G_v = 1 + R2/R1$ and input signal equal to V_{ref} , variability of the output voltage can be obtained by varying $R1$ or $R2$ (or both). It's best to vary $R1$ because in this way the current in resistors $R1$ and $R2$ remains constant (this current is in fact given by $V_{ref}/R1$).

Equation(1) can also be found in another way which is more useful in order to understand the descriptions of the applications discussed.

$$V_{out} = R1\ i_1 + R2\ i_2$$

and since in practice $i_1 \gg i_2$ (i_2 has a typical value of 10 μ A) we can say that

$$V_{out} + R1\ i_1 + R2\ i_1 \text{ with } i_1 = \frac{V_{ref}}{R1}$$

Therefore

$$V_{out} = \frac{R2}{R1} V_{ref} + V_{ref} = V_{ref} \left(1 + \frac{R2}{R1} \right)$$

In other words $R1$ fixes the value of the current circulating in $R2$ so $R2$ is determined.

APPLICATION NOTE

Figure 1 : Block Diagram.

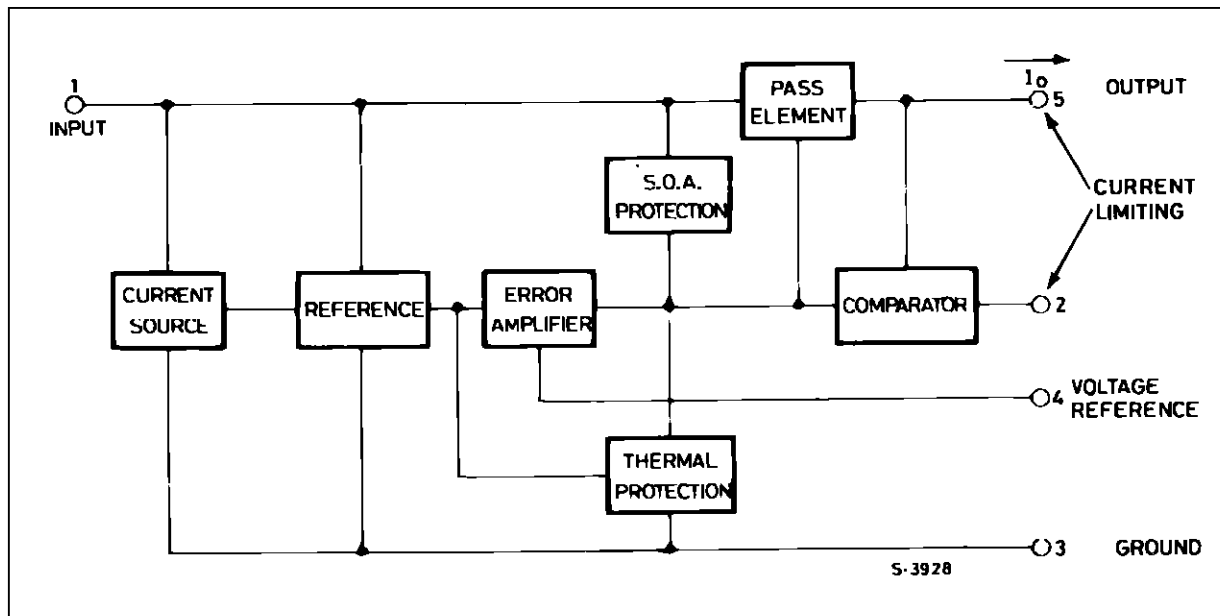

Figure 2 : Schematic Diagram.

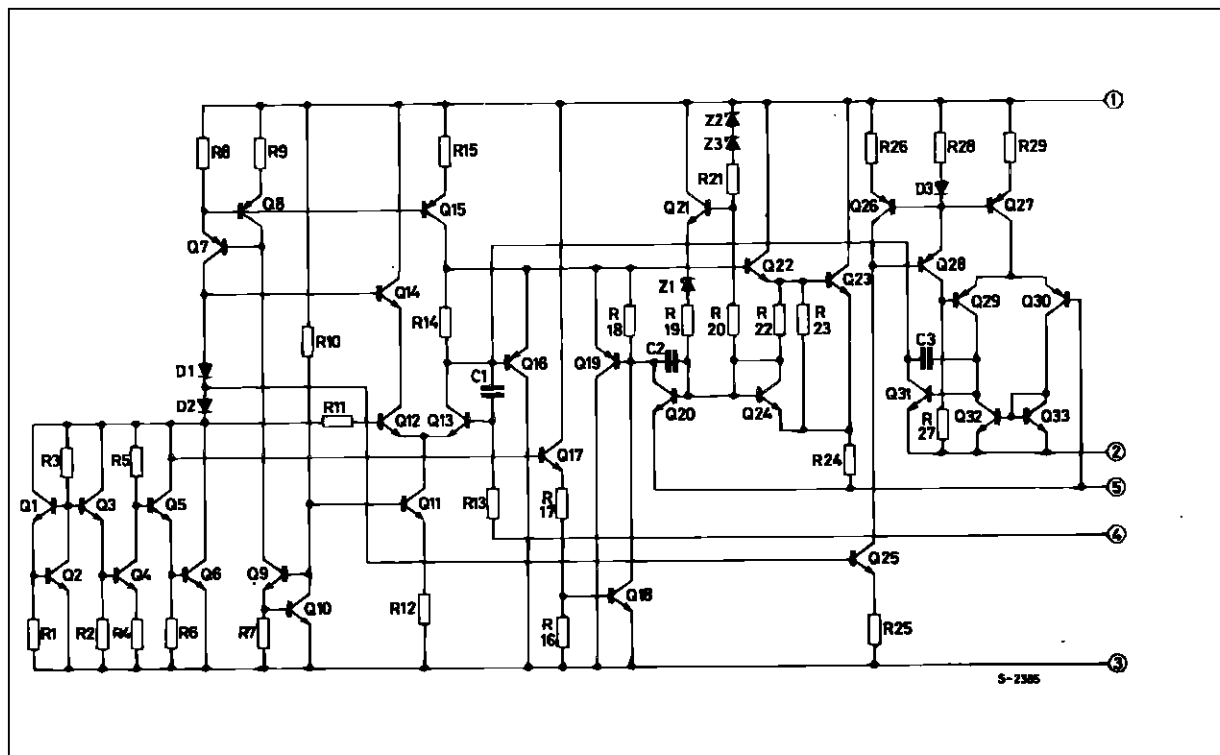
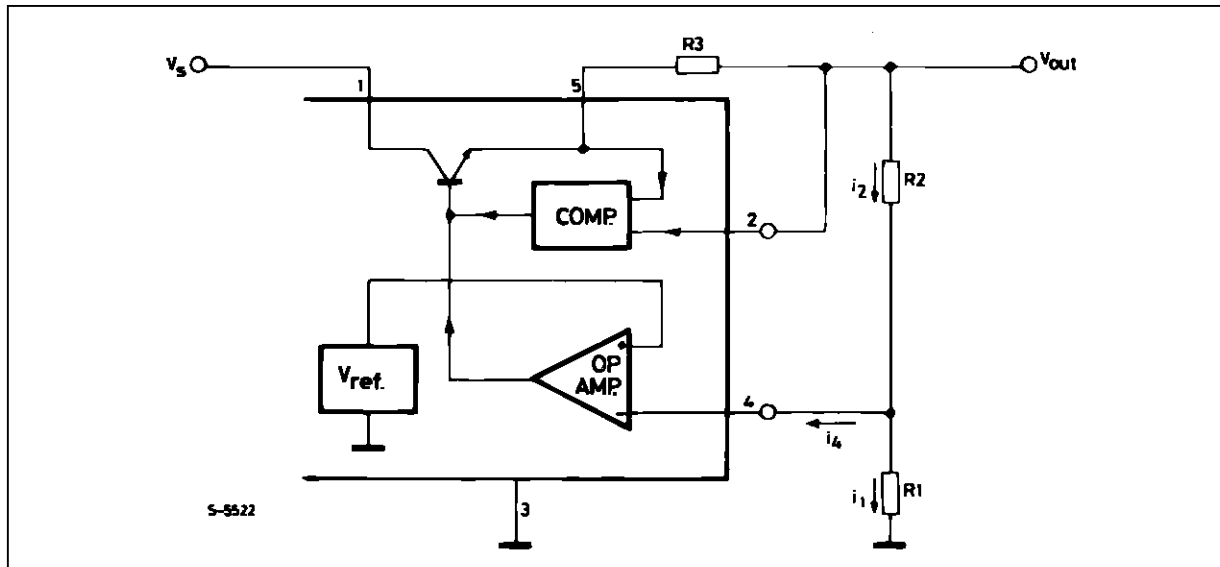

Figure 3.



OVERLOAD PROTECTION

The device has an overload protection circuit which limits the current available.

Referring to fig. 2, R24 operates as a current sensor. When at the terminals of R24 there is a voltage drop sufficient to make Q20 conduct, Q19 begins to draw current from the base of the power transistor (darlington formed by Q22 and Q23) and the output current is limited. The limit depends on the current which Q21 injects into the base of Q20. This current depends on the drop-out and the temperature which explains the trend of the curves in fig. 4.

Figure 4.

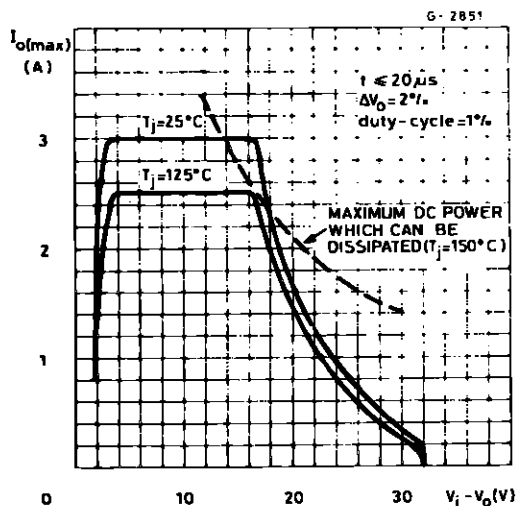

THERMAL PROTECTION

The junction temperature of the device may reach destructive levels during a short circuit at the output or due to an abnormal increase in the ambient temperature. To avoid having to use heatsinks which are costly and bulky, a thermal protection circuit has been introduced to limit the output current so that the dissipated power does not bring the junction temperature above the values allowed. The operation of this circuit can be summarized as follows.

In Q17 there is a constant current equal to :

$$\frac{V_{ref} - V_{BE17}}{R17 + R16} \quad (V_{ref} = 2.75 \text{ V typ})$$

The base of Q18 is therefore biased at :

$$V_{BE18} = \frac{V_{ref} - V_{BE17}}{R16 + R17} \quad \bullet R16 \cong 350 \text{ m}\Omega$$

Therefore at $T_j = 25^\circ\text{C}$ Q18 is off (since 600 mV is needed for it to start conducting). Since the V_{BE} of a silicon transistor decreases by about 2 mV/ $^\circ\text{C}$, Q18 starts conducting at the junction temperature :

$$T_j = \frac{600 - 350}{2} + 25 = 150^\circ\text{C}$$

CURRENT LIMITATION

The innovative feature of this device is the possibility of acting on the current regulation loop, i.e. of limiting the maximum current that can be supplied to the desired value by using a simple resistor (R3 in fig. 2). Obviously if $R3 = 0$ the maximum output current is

APPLICATION NOTE

also the maximum current that the device can supply because of its internal limitation.

The current loop consists of a comparator circuit with fixed threshold whose value is V_{SC} . This comparator intervenes when $I_o \cdot R_3 = V_{SC}$, hence

$$I_o = \frac{V_{SC}}{R_3} \quad (V_{SC} \text{ is the voltage between pin 5 and 2 with typical value of } 0.45 \text{ V}).$$

Special attention has been given to the comparator circuit in order to ensure that the device behaves as a current generator with high output impedance.

Special attention has been given to the comparator circuit in order to ensure that the device behaves as a current generator with high output impedance.

TYPICAL APPLICATIONS

PROGRAMMABLE CURRENT REGULATOR

Fig. 5 shows the device used as current generator. In this case the error amplifier is disabled by short-circuiting pin 4 to ground.

Figure 5.

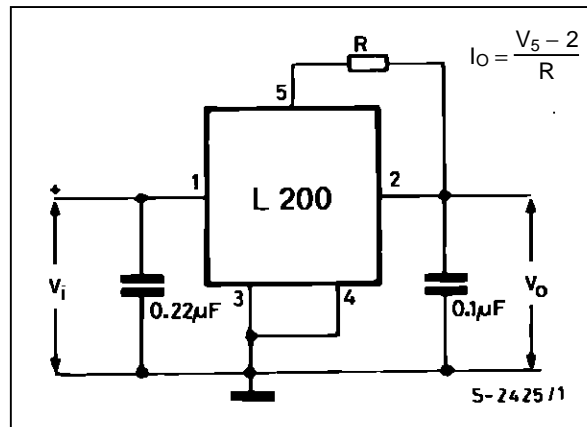

The output current I_o is fixed by means of R :

$$I_o = \frac{V_5 - 2}{R}$$

The output voltage can reach a maximum value $V_i - V_{drop} \cong V_i - 2 \text{ V}$ (V_{drop} depends on I_o).

PROGRAMMABLE VOLTAGE REGULATOR

Fig. 6 shows the device connected as a voltage regulator and the maximum output current is the maximum current that the device can supply. The output voltage V_o is fixed using potentiometer R_2 . The equation which gives the output voltage is as follows :

$$V_o = V_{ref} \left(1 + \frac{R_2}{R_1} \right)$$

By substituting the potentiometer with a fixed resistor and choosing suitable values for R_1 and R_2 , it is

possible to obtain a wide range of fixed output voltages.

Figure 6.

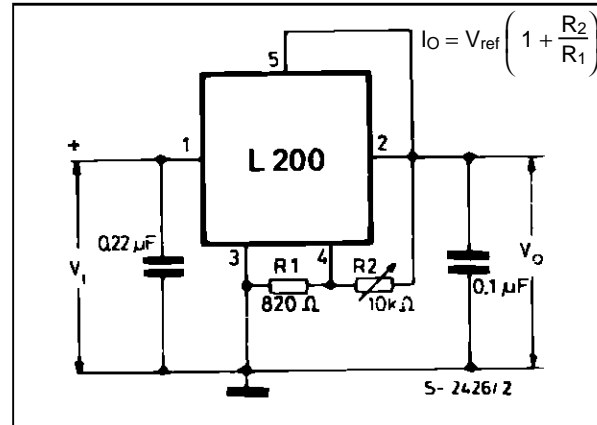

The following formulas and tables can be used to calculate some of the most common output voltages.

Having fixed a certain V_o , using the previous formula, the maximum value is :

$$V_{O \max} = V_{ref \max} \left(1 + \frac{R_{2 \max}}{R_{1 \min}} \right) \quad \text{and the}$$

minimum value is :

$$V_{O \min} = V_{ref \min} \left(1 + \frac{R_{2 \min}}{R_{1 \max}} \right)$$

The table below indicates resistor values for typical output voltages :

$V_o \pm 4\%$	$R_1 \pm 1\%$	$R_2 \pm 1\%$
5V	1.5k Ω	1.2k Ω
12V	1k Ω	3.3k Ω
15V	750 Ω	3.3k Ω
18V	330 Ω	1.8k Ω
24V	510 Ω	3.9k Ω

PROGRAMMABLE CURRENT AND VOLTAGE REGULATOR

The typical configuration used by the device as a voltage regulator with external current limitation is shown in fig. 7. The fixed voltage of 2.77 V at the terminals of R_1 makes it possible to force a constant current across variable resistor R_2 . If R_2 is varied, the voltage at pin 2 is varied and so is the output voltage.

The output voltage is given by :

$$V_O = V_{ref} \cdot \left(1 + \frac{R_2}{R_1} \right), \text{ with } V_{ref} = 2.77 \text{ V typ}$$

and the maximum output current is given by :

$$I_{O \max} = \frac{V_{5-2}}{R_3} \text{ with } V_{5-2} = 0.45 \text{ V typ.}$$

To maintain a sufficient current for good regulation the value of R1 should be kept low. When there is no load, the output current is V_{ref}/R_1 . Suitable values of R1 are between 500 Ω and 1.5 kΩ. If the load is always present the maximum value for R1 is limited by the current value (10 μA) at the input of the error amplifier (pin 4).

Figure 7.

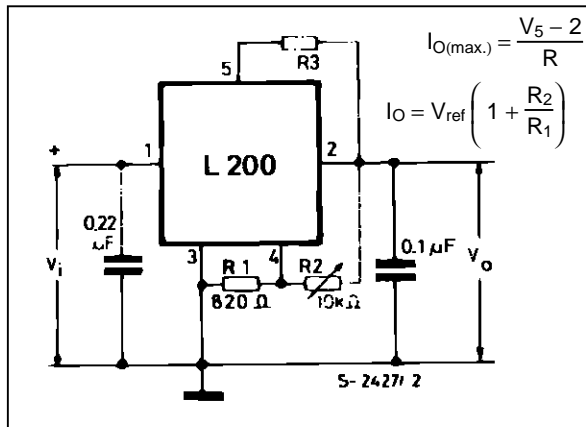

DIGITALLY SELECTED REGULATOR WITH INHIBIT

The output voltage of the device can be regulated digitally as shown in fig. 8. The output voltage depends on the divider formed by R5 and a combination of R1, R2, R3 and P2. The device can be switched off with a transistor.

When the inhibit transistor is saturated, pin 2 is brought to ground potential and the output voltage does not exceed 0.45 V.

REDUCING POWER DISSIPATION WITH DROPPING RESISTOR

It may sometimes be advisable to reduce the power dissipated by the device. A simple and economic method of doing this is to use a resistor connected in series to the input as shown in fig. 9. The input-output differential voltage on the device is thus reduced.

The formula for calculating R is as follows :

$$R = \frac{V_{i \min} - (V_O + V_{drop})}{I_O}$$

Figure 8.

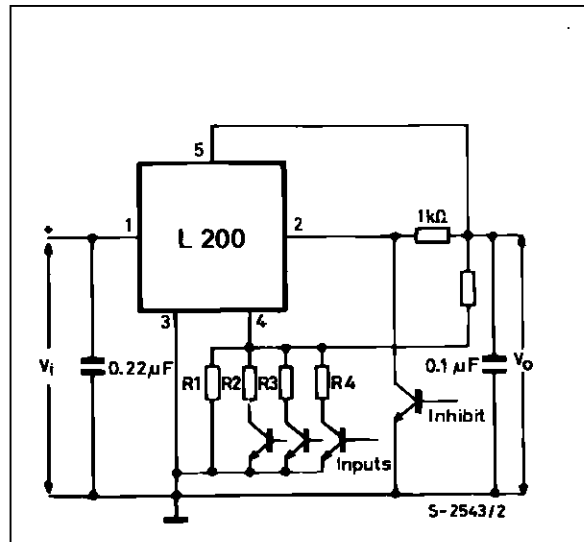
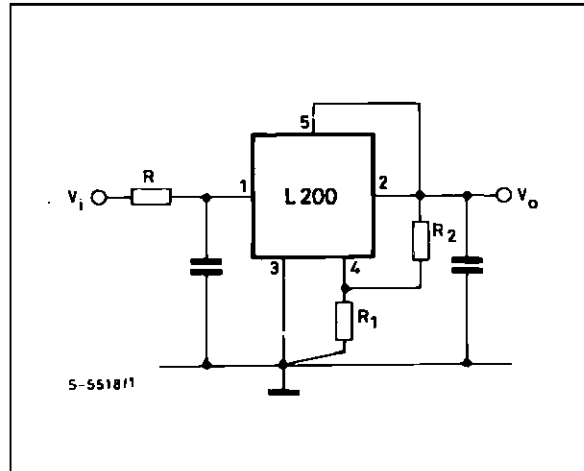

Figure 9.



Where V_{drop} is the minimum differential voltage between the input and the output of the device at current I_O . $V_{in \min}$ is the minimum voltage. V_O is the output voltage and I_O the output current.

With constant load, resistor R can be connected between pins 1 and 2 of the IC instead of in series with the input (fig. 10). In this way, part of the load current flows through the device and part through the resistor. This configuration can be used when the minimum current by the load is :

$$I_{O \min} = \frac{V_{drop}}{R} \text{ (instant by instant)}$$

APPLICATION NOTE

Figure 10.

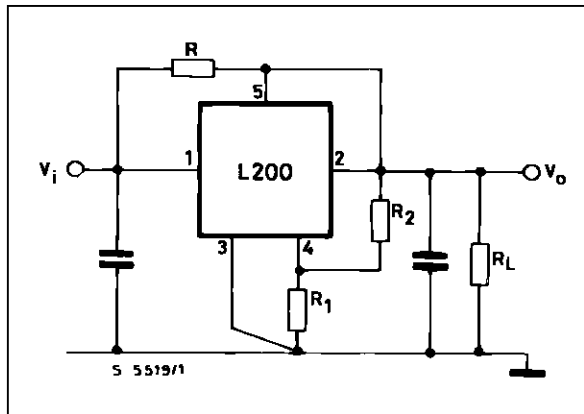

SOFT START

When a slow rise time of the output voltage is required, the configuration in fig. 11 can be used. The rise time can be found using the following formula :

$$t_{on} = \frac{CV_o R}{0.45}$$

At switch on capacitor C is discharged and it keeps the voltage at pin 2 low ; or rather, since a voltage of more than 0.45 V cannot be generated between pins 5 and 2, the V_o follows the voltage at pin 2 at less than 0.45 V.

Figure 11.

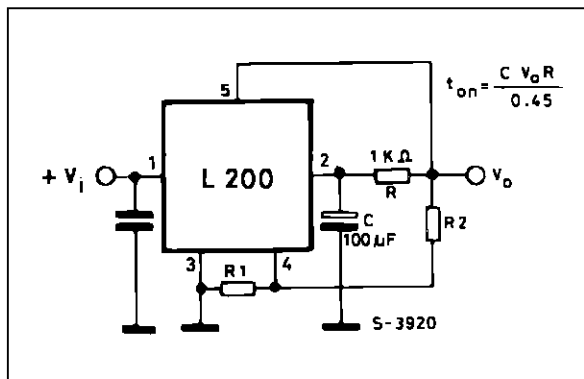

Capacitor C is charged by the constant current i_c .

$$i_c = \frac{V_{sc}}{R}$$

Therefore the output reaches its nominal value after the time t_{on} :

$$V_o - V_{sc} = \frac{i_c \cdot t_{on}}{C}$$

$$t_{on} = C \cdot \frac{V_o - 0.45}{0.45} \cdot R \cong \frac{CV_o R}{0.45}$$

LIGHT CONTROLLER

Fig. 12 shows a circuit in which the output voltage is controlled by the brightness of the surrounding environment. Regulation is by means of a photo resistor in parallel with R1. In this case, the output voltage increases as the brightness increases. The opposite effect, i.e. dimming the light as the ambient light increases, can be obtained by connecting the photoresistor in parallel with R2.

Figure 12.

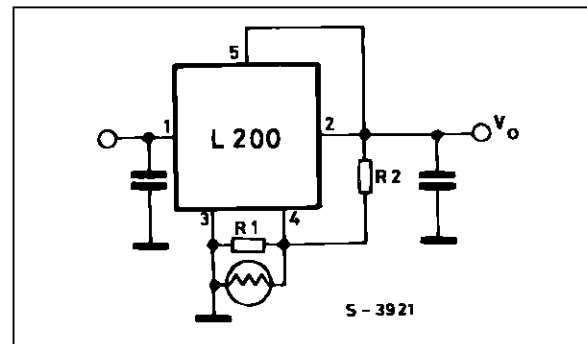

LIGHT DIMMER FOR CAR DISPLAY

Although digital displays in cars are often more aesthetically pleasing and frequently more easily read they do have a problem. Under varying ambient light conditions they are either lost in the background or alternatively appear so bright as to distract the driver. With the system proposed here, this problem is overcome by automatically adjusting the display brightness during daylight conditions and by giving the driver control over the brightness during dusk and darkness conditions.

The circuit is shown in fig. 13. The primary supply is shown taken straight from the car battery however it is worth noting that in a car there is always the risk of dump voltages up to 120 V and it is recommended that some form of protection is included against this.

Under daylight conditions i.e. with sidelights off and T1 not conducting the output of the device is determined by the values of R1, R2 and the photoresistor (PTR). The output voltage is given by

$$V_{out} = V_{ref} \left(1 + \frac{R2}{PTR/R1} \right)$$

If the ambient light intensity is high, the resistance of the photoresistor will be low and therefore V_{out} will be high. As the light decreases, so V_{out} decreases dimming the display to a suitable level.

Figure 13.

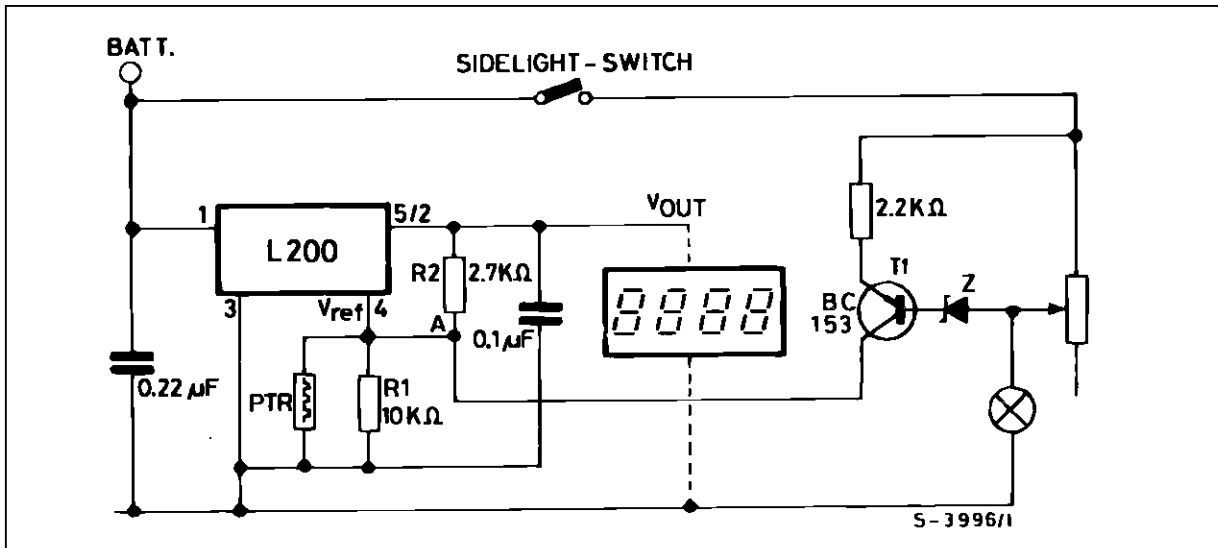

In dusk conditions, when the sidelights are switched on, T1 starts to conduct with its conduction set by the potentiometer wiper at its uppermost position the sidelights are at their brightest and current through T1 would be a minimum. With the wiper at its lowest position obviously the opposite conditions apply.

The current through T1 is felt at the summing node A along with the currents through R2 and the parallel network R1, PTR. Since V_{ref} is constant the current flowing through R1, PTR must also be constant. Therefore any change in the current through T1 causes an equal and opposite change in the current through R2. Therefore as I_{T1} increases, V_{out} decreases i.e. as the brightness of the side-lights is increased or decreased so is the brightness of the display.

The values of R2 and PTR should be selected to give the desired minimum and maximum brightness levels desired under both automatic and manual conditions although the minimum brightness under manual conditions can also be set by the maximum current flowing through T1 and, in any case, this should not exceed the maximum current through R2 under automatic operation.

The circuit shown with a small modification can also be used for dimmers other than in a car. Fig. 15 shows the modification needed. The zener diode should have a V_F ≥ 2.5 V at I = 10 μA.

HIGHER INPUT OR OUTPUT VOLTAGES

Certain applications may require higher input or output voltages than the device can produce. The problem can be solved by bringing the regulator back into

Figure 14.

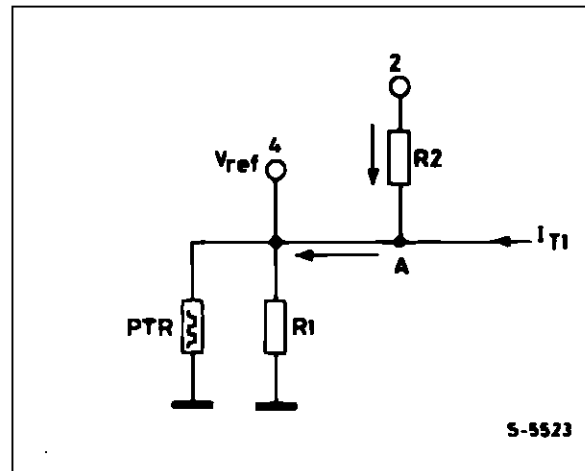
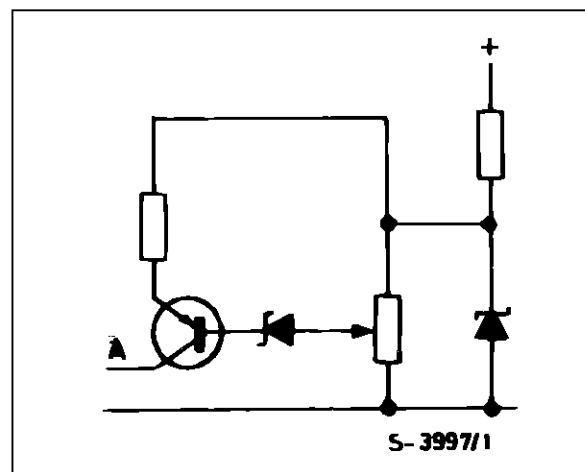

Figure 15.



APPLICATION NOTE

the normal operating units with the help of external components.

When there are high input voltages, the excess voltage must be absorbed with a transistor. Figs. 16 and 17 show the two circuits :

Figure 16.

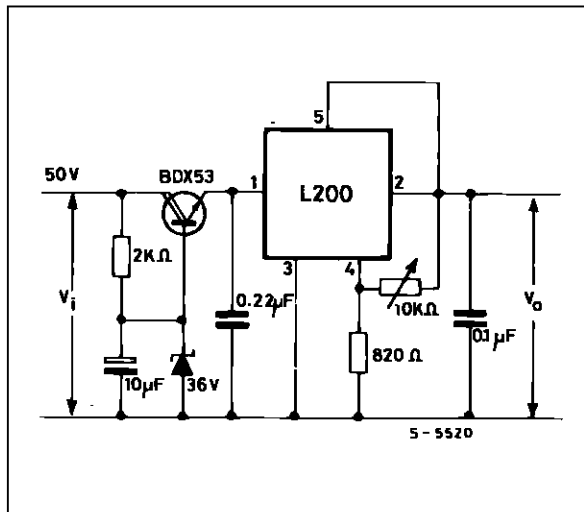
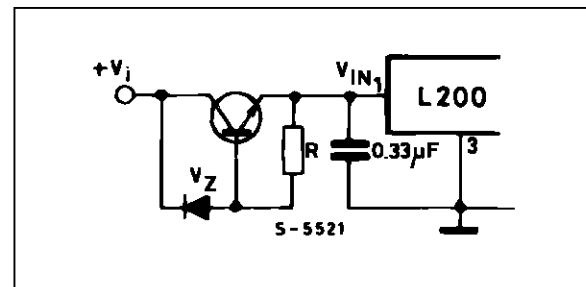

Figure 17.



The designer must take into account the dissipated power and the SOA of the preregulation transistor. For example, using the BDX53, the maximum input voltage can reach 56 V (fig. 16). In these conditions we have 20 V of V_{CE} on the transistor and with a load current of 2 A the operation point remains inside the SOA. The preregulation used in fig. 16 reduces the ripple at the input of the device, making it possible to obtain an output voltage with negligible ripple.

If high output voltages are also required, a second zener, V_z , is used to refer the ground pin of an IC to a potential other than zero ; diode D1 provides output shortcircuit protection (fig. 18).

Figure 18.

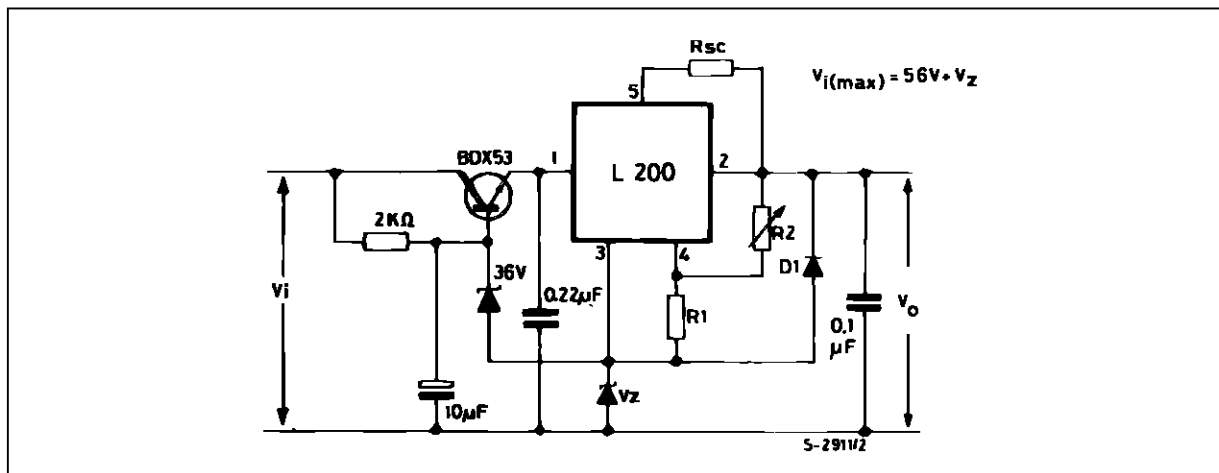

POSITIVE AND NEGATIVE VOLTAGE REGULATORS

The circuit in fig. 19 provides positive and negative balanced, stabilized voltages simultaneously. The L200 regulator supplies the positive voltage while the negative is obtained using an operational amplifier connected as follower with output current booster.

Tracking of the positive voltage is achieved by putting the non-inverting input to ground and using the inverting input to measure the feedback voltage coming from divider R1-R2.

The system is balanced when the inputs of the operational amplifier are at the same voltage, or, since one input is at fixed ground potential, when the voltage of the intermediate point of the divider goes to 0 Volts. This is only possible if the negative voltage, on command of the op-amp, goes to a value which will make a current equal to that in R1 flows in R2. The ratio which expresses the negative output voltage is :

$$V^- = V^+ \cdot \frac{R_2}{R_1} \quad (\text{If } R_2 = R_1, \text{ we'll get } V^- = V^+)$$

Figure 19.

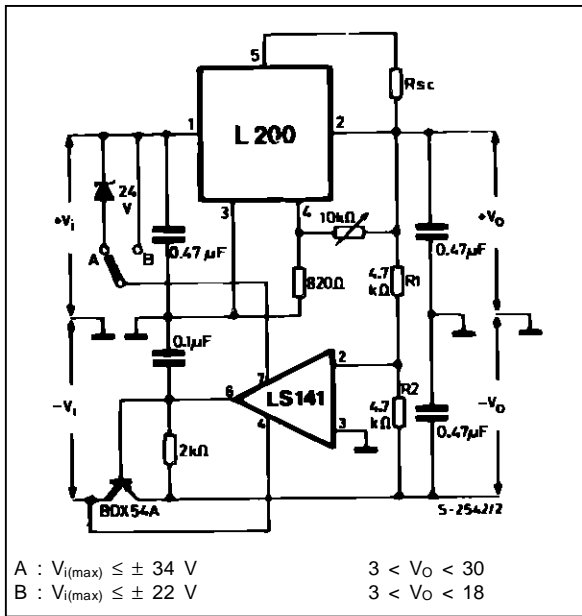

Since the maximum supply voltage of the op amp used is ± 22 V, when pin 7 is connected to point B output voltages up to about 18 V can be obtained. If on the other hand pin 7 is connected to point A, much higher output voltages, up to about 30 V, be obtained since in this case the input voltage can rise to 34 V.

Fig. 20 shows a diagram in which the L165 power op amp is used to produce the negative voltage. In this case (as in fig. 19) the output voltage is limited by the absolute maximum rating of the supply voltage of the L165 which is ± 18 V. Therefore to get a higher V_{out} we must use a zener to keep the device supply within the safety limits.

If we have a transformer with two separate secondaries, the diagram of fig. 21 can be used to obtain independent positive and negative voltages. The two output diodes, D1 and D2, protect the devices from shortcircuits between the positive and negative outputs.

Figure 20.

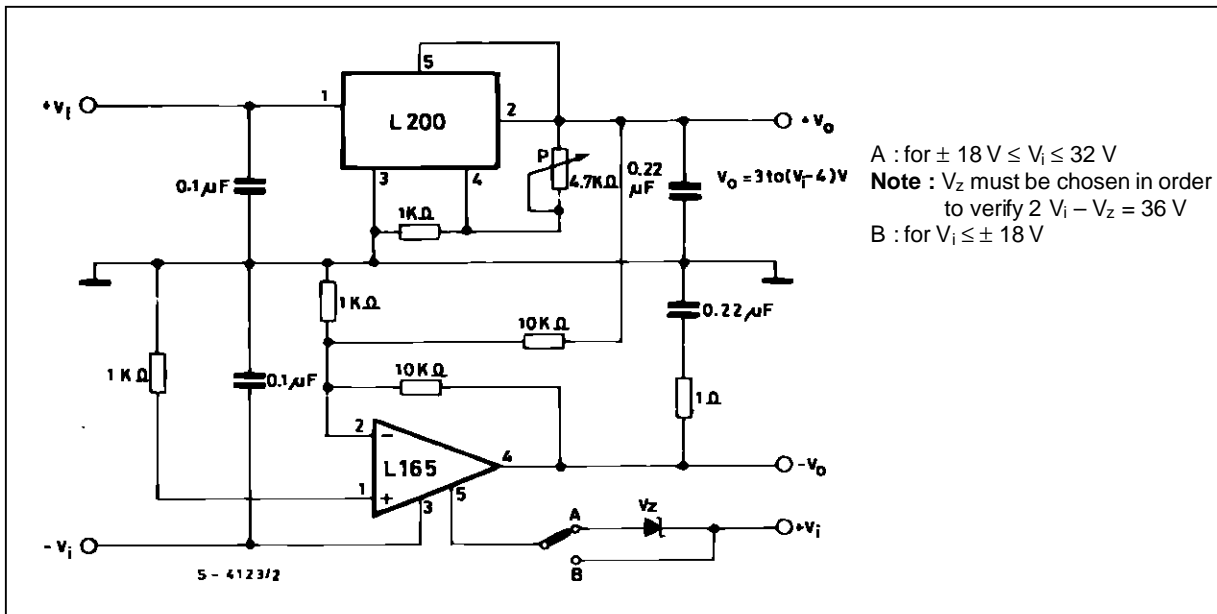

Figure 23.

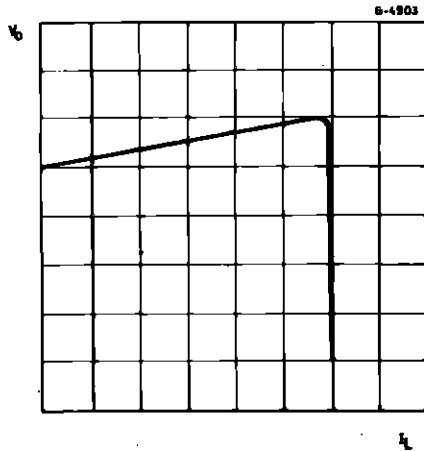
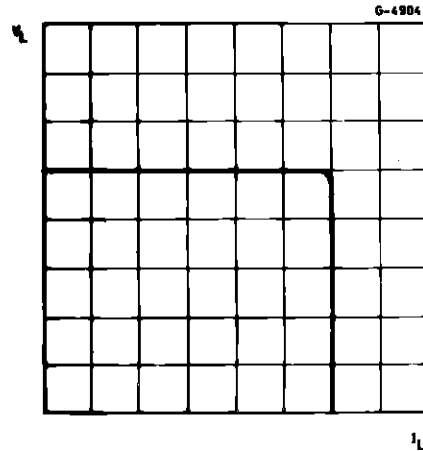

Figure 24.



MOTOR SPEED CONTROL

Fig. 25 shows how to use the device for the speed control of permanent magnet motors. The desired speed, proportional to the voltage at the terminal of the motor, is obtained by means of R1 and R2.

$$V_M = V_{ref} \left(1 + \frac{R_2}{R_1} \right)$$

To obtain better compensation of the internal motor resistance, which is essential for good regulation, the following equation is used :

$$R_3 \leq \frac{R_1}{R_2} \cdot R_M$$

This equation works with infinite R4. If R4 is finite, the motor speed can be increased without altering the ratio R2/R1 and R3. Since R4 has a constant voltage (V_{ref}) at its terminals, which does not vary as R4 varies, this voltage acts on R2 as a constant current source variable with R4. The voltage drop on R2 thus increases, and the increase is felt by the voltage at the terminals of the motor. The voltage increase at the motor terminals is :

$$V_M = \frac{V_{ref}}{R_4 + R_3} \cdot R_2$$

A circuit for a 30 W motor with R_M = 4 Ω, R₁ = 1 kΩ, R₂ = 4.3 kΩ, R₄ = 22 kΩ and R₃ = 0.82 Ω has been realized.

POWER AMPLITUDE MODULATOR

In the configuration of fig. 26 the L200 is used to send a signal onto a supply line. Since the input signal V_i is DC decoupled, the V_o is defined by :

$$V_O = V_{ref} \left(1 + \frac{R_2}{R_1} \right)$$

Figure 25.

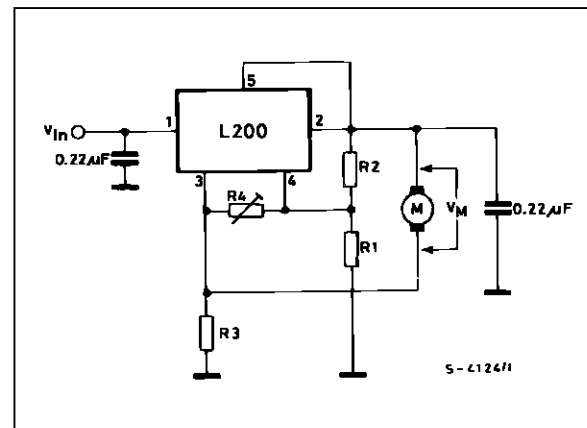

The amplified signal V_i whose value is :

$$G_V = - \frac{R_2}{R_3}$$

is added to this component. By ignoring the current entering pin 4, we must impose i₁ = i₂ + i₃ (1) and since the voltage between pin 4 and ground remains fixed (V_{ref}) as long as the device is not in saturation, i₁ = 0 and equation (1) becomes :

$$i_2 = -i_3 \text{ with } i_3 = \frac{V_i}{R_3} \quad (\text{for } X_c \ll R_3) \text{ Therefore}$$

$$V_o = R_2 i_2 = - \frac{V_i}{R_3} \cdot R_2$$

An application is shown in fig. 27. If the DC level is to be varied but not the AC gain, R₁ should be replaced by a potentiometer.

APPLICATION NOTE

Figure 26.

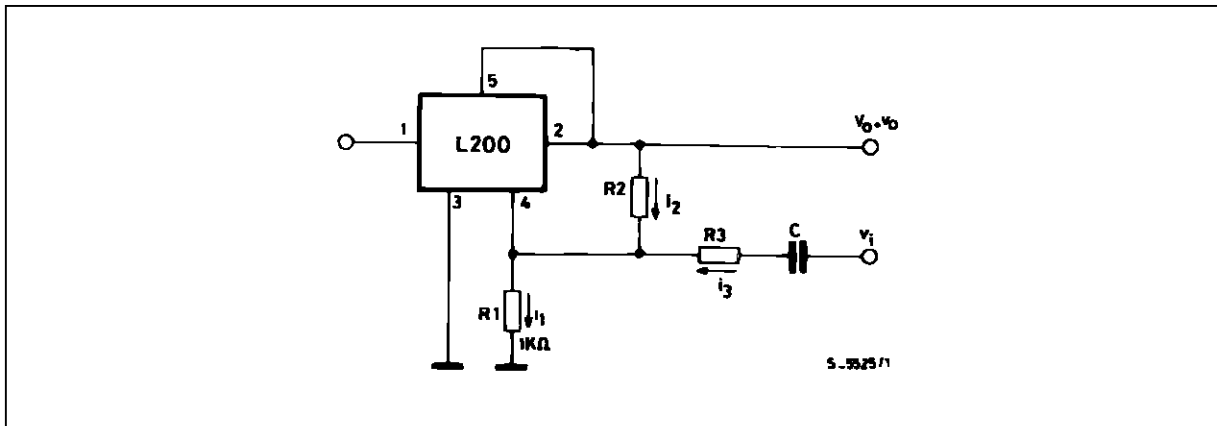
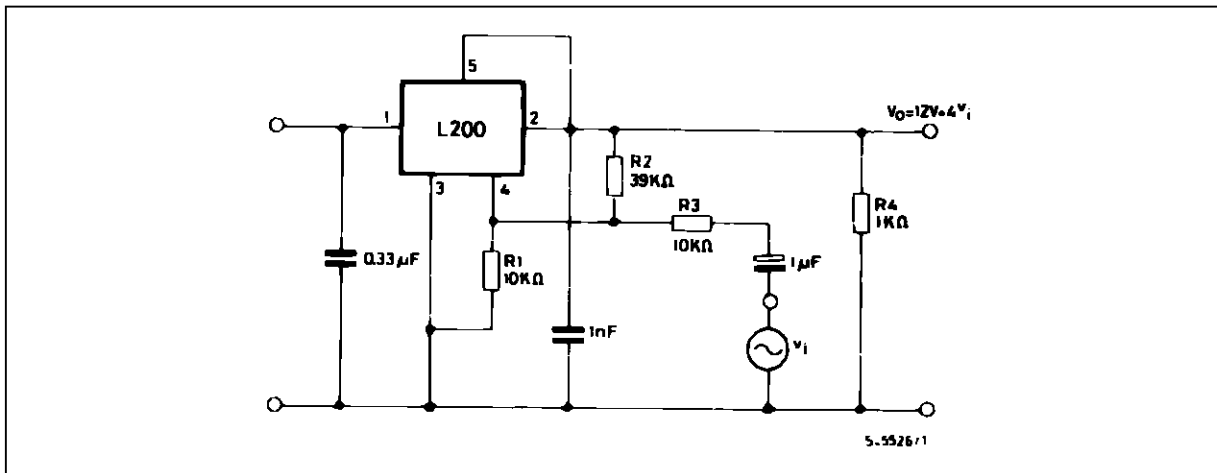

Figure 27.



HIGH CURRENT REGULATORS

To get a higher current than can be supplied by a single device one or more external power transistors must be introduced. The problem is then to extend all the device's protection circuits (short-circuit protection, limitation of T_j of external power devices and overload protection) to the external transistors. Constant current or foldback current limitation therefore becomes necessary.

When the regulator is expected to withstand a permanent shortcircuit, constant current limitation becomes more and more difficult to guarantee as the nominal V_o increases. This is because of the increase in V_{CE} at the terminals of the transistor, which leads to an increase in the dissipated power. The heatsink has to be calculated in the heaviest working conditions, and therefore in shortcircuit. This increases weight, volume and cost of the heatsink and increase of the ambient temperature (because of high power dissipation). Besides heatsink, power

transistors must be dimensioned for the short-circuit.

This type, of limitation is suited, for example, with highly capacitive loads. Efficiency is increased if pre-regulation is used on the input voltage to maintain a constant drop-out on the power element for all V_{out} , even in shortcircuit. Foldback limitation, on the other hand, allows lighter shortcircuit operating conditions than the previous case. The type of load is important.

If the load is highly capacitive, it is not possible to have a high ratio between I_{max} and I_{sc} because at switch-on, with load inserted, the output may not reach its nominal value.

Other protection against input shortcircuit, mains failure, overvoltages and output reverse bias can be realized using two diodes, D1 and D2, inserted as indicated in fig. 28.

Figure 28.

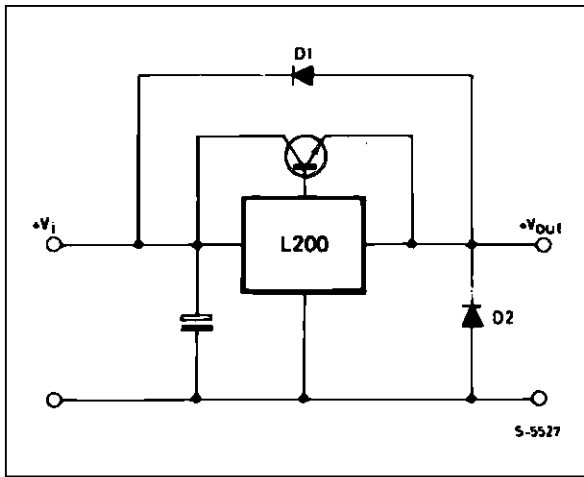

USE OF A PNP TRANSISTOR

Fig. 29 shows the diagram of a high current supply using the current limitation of the L200. The output current is calculated using the following formula :

$$I_o = \frac{V_{SC}}{R_{SC}} \cong \frac{0.45 \text{ V}}{0.1 \Omega} = 4.5 \text{ A}$$

Constant current limitation is used ; so, in output shortcircuit conditions, the transistor dissipates a power equal to :

$$P_D = V_i \cdot I_o = V_i \cdot \frac{V_{SC}}{R_{SC}}$$

The operating point of the transistor should be kept well within the SOA ; with $R_{SC} = 0.1 \Omega$, V_i must not exceed 20 V. Part of the I_o crosses the transistor and part crosses the regulator.

Figure 30.

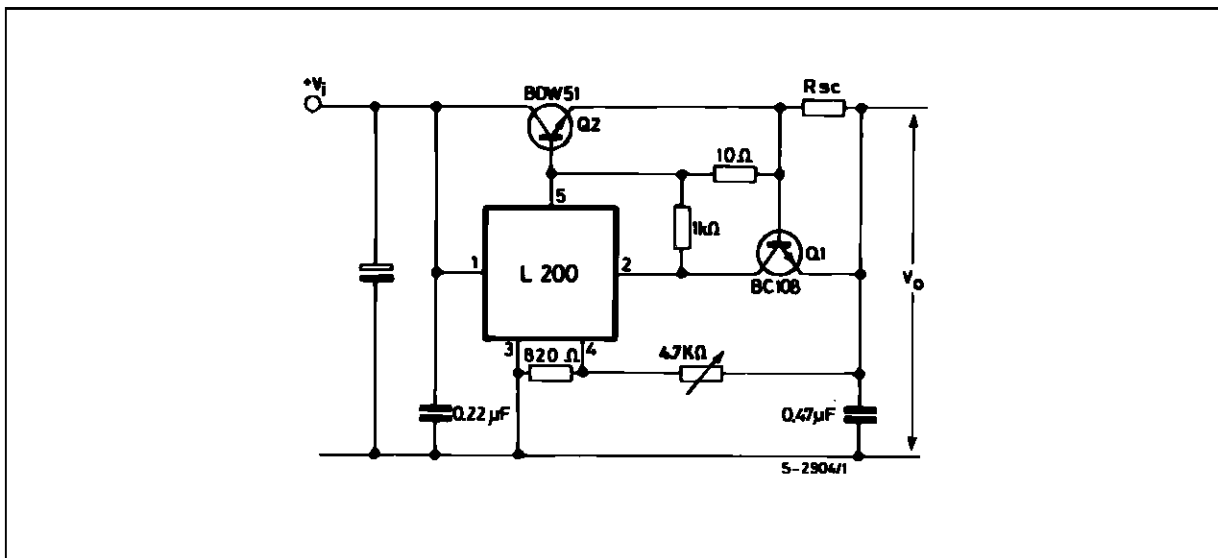
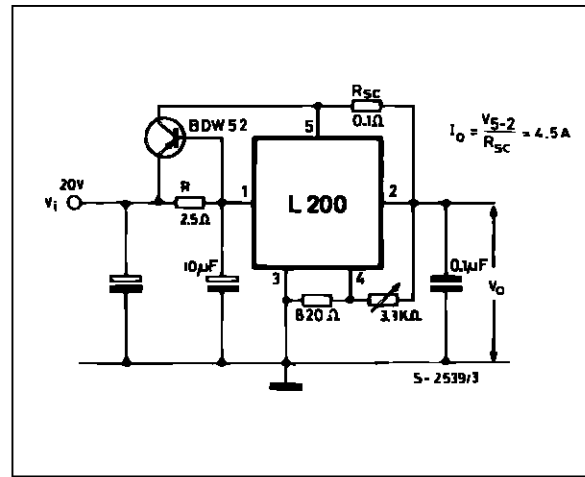

Figure 29.



The latter is given by : $I_{REG} = I_B + \frac{V_{BE}}{R}$

where I_B is the base current of the transistor (-100 mA at $I_C = 4 \text{ A}$) and V_{BE} is the base-emitter voltage (-1 V at $I_C = 4 \text{ A}$) ; with $R = 2.5 \Omega$, $I_{REG} \cong 500 \text{ mA}$.

USE OF AN NPN POWER TRANSISTOR

Fig. 30 shows the same application as described in figure 29, using an NPN power transistor instead of a PNP. In this case an external signal transistor must be used to limit the current. Therefore :

$$I_o = \frac{V_{BE Q1}}{R_{SC}}$$

As regards the output shortcircuit, see par. 1.5.

APPLICATION NOTE

12V - 4A POWER SUPPLY

The diagram in fig. 31 shows a supply using the L200 and the BD705. The 1 k Ω potentiometer, PT1, together with the 3.3k resistor are used for fine regulation of the output voltage.

Current limitation is of the type shown in fig. 32. Trimmer PT2 acts on stretch AB of characteristic. With the values indicated (PT2 = 1 k Ω , PT3 = 470 Ω , R = 3 k Ω), currents from 3 to 4 A can be limited. The field of variation can be increased by increasing the value of Rsc or by connecting one terminal of PT to the base of the power transistor, which, however, provides less stable limitation. If section AB is moved, section BC will also be moved.

The slope of BC can be varied using PT3. The voltage level at point B is fixed by the voltage of the zener diode. The capacitor in parallel to the zener ensures correct switch-on with full load. The BD705 should always be used well within its safe operating area. If this is not possible two or more BD705s should be used, connected in parallel (fig. 33).

Further protection for the external power transistor can be provided as shown in fig. 34. The PTC resistor, whose temperature intervention point must prevent the T_j of the power transistor from reaching its maximum value, should be fixed to the dissipator near the power transistor. Dimensioning of R_A and R_B depends on the PTC used.

Figure 31.

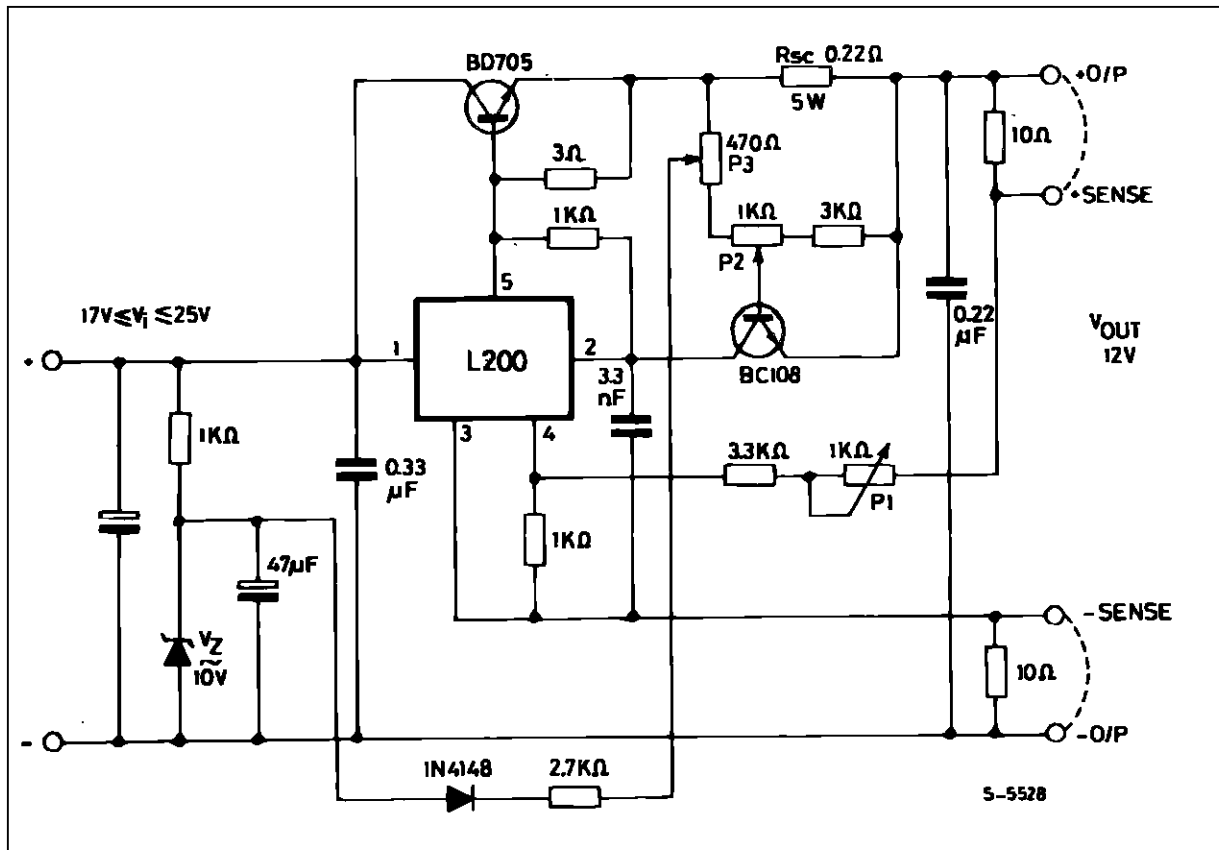

Figure 32.

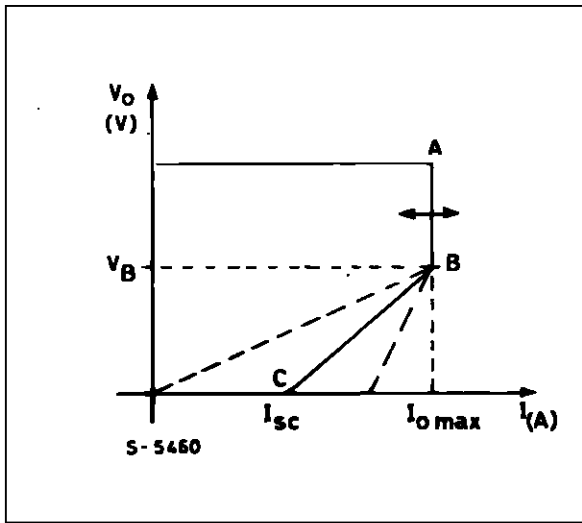

Figure 33.

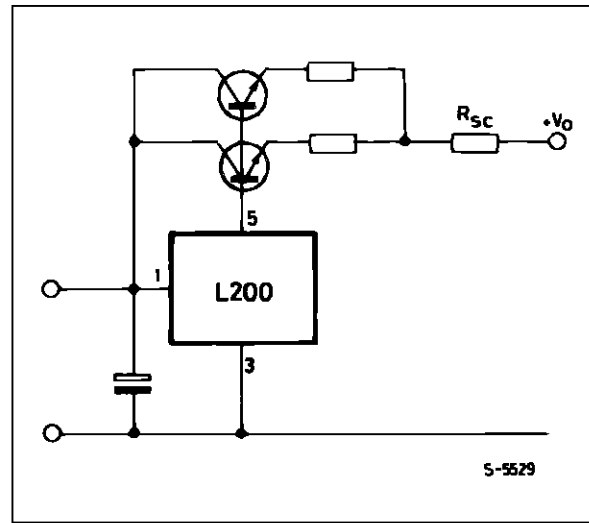
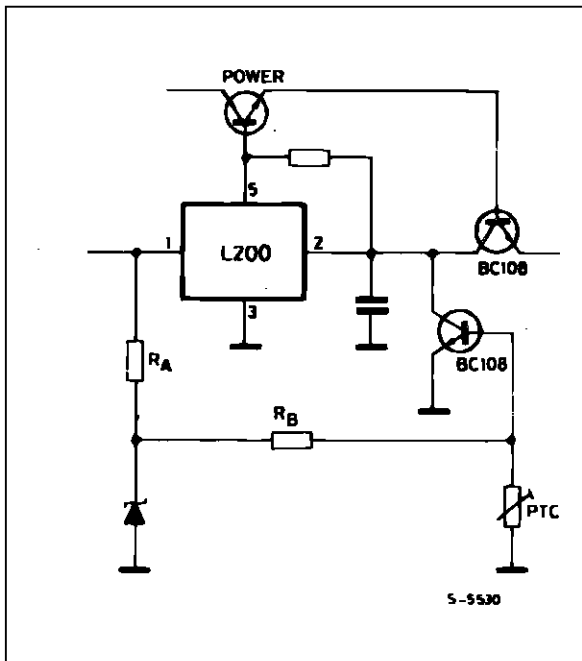

Figure 34.



VOLTAGE REGULATOR FROM 0V TO 16V - 4.5A

Fig. 35 shows an application for a high current supply with output voltage adjustable from 0 V to 16 V, realized with two L200 regulators and an external power transistor. With the values indicated, the current can be regulated from 2 A to 4.5 A by potentiometer PT2. PT1, on the other hand, is used for constant current or foldback current limitation. The integrated circuit IC2, which does not require a heatsink and has excellent temperature stability, is used to obtain the 0 V output. It is connected so as to lower pin 3 of IC1 until pin 4 reaches 0 V. Q1 and Q2 ensure correct operation of the supply at switch-on and switch-off.

APPLICATION NOTE

Figure 35.

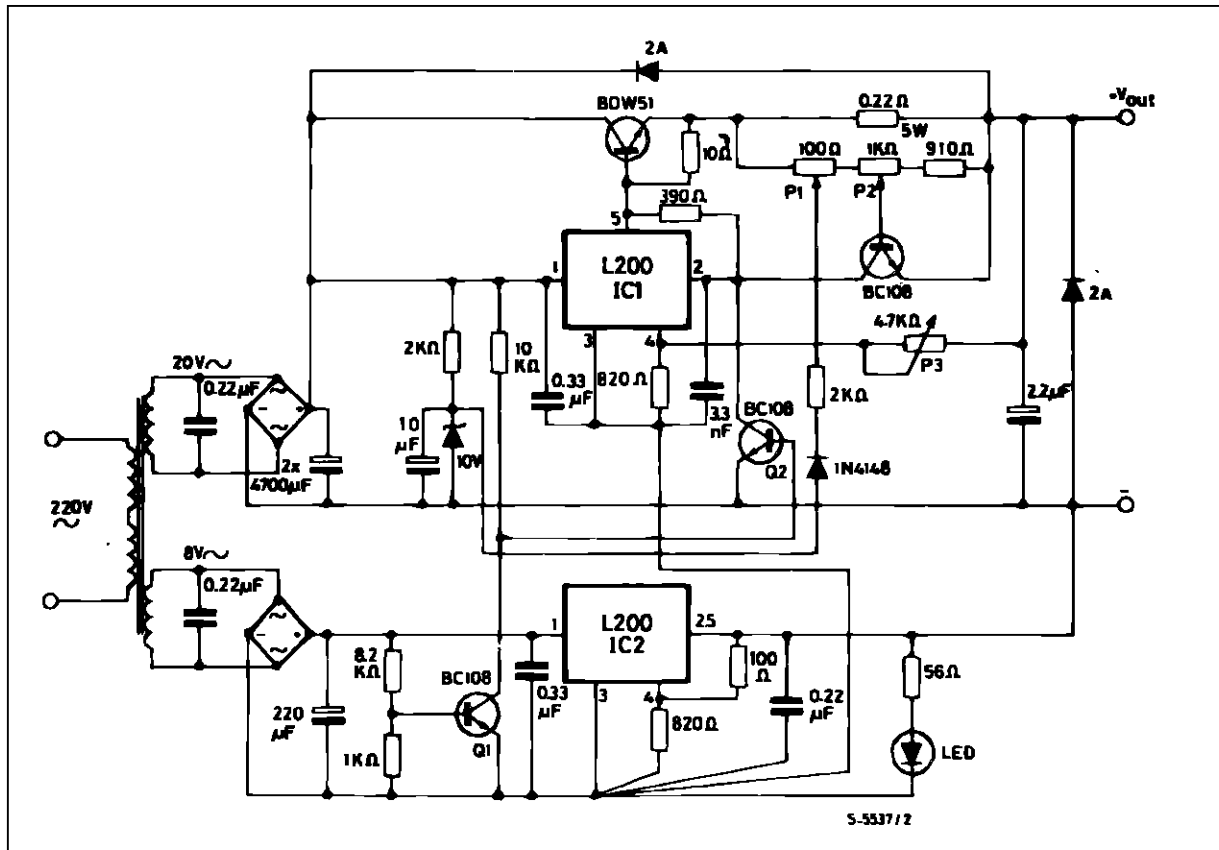

POWER SUPPLY WITH $V_o = 2.8$ TO 18 V, $I_o = 0$ TO 2.5 A

The diagram in fig. 36 shows a supply with output voltage variable from 2.8 V to 18 V and constant current limitation from 0 A to 2.5 A. The output current can be regulated over a wide range by means of the op. amp. and signal transistor TR_2 . The op. amp. and the transistor are connected in the voltage-current converter configuration. The voltage is taken at the terminals of R_3 and converted into current by PT_2 .

I_o is fixed as follows :

$$\frac{R_4 I_o}{PT_2} = I_1 (*) \quad (**) I_{sc} = \frac{V_{sc}}{R_2}$$

When $I_1 = I_{sc}$, the regulator starts to operate as a current generator. By making (*) equal to (**) we get :

$$\frac{R_4 I_o}{PT_2} = \frac{V_{sc}}{R_2} \quad \text{Therefore } I_o = \frac{V_{sc}}{R_2 \cdot R_4} \cdot PT_2$$

Diodes D_1 and D_2 keep transistor TR_2 in linear condition in the case of small output currents. If it is not necessary to limit the current to zero, one of the diodes can be eliminated : the second diode could also be eliminated if TR_1 were a darlington instead of a transistor.

The op. amp. must have inputs compatible with ground in order to guarantee current limitation even in shortcircuit. With a negative voltage available, even of only a few volts, current limitation is simplified.

Figure 36.

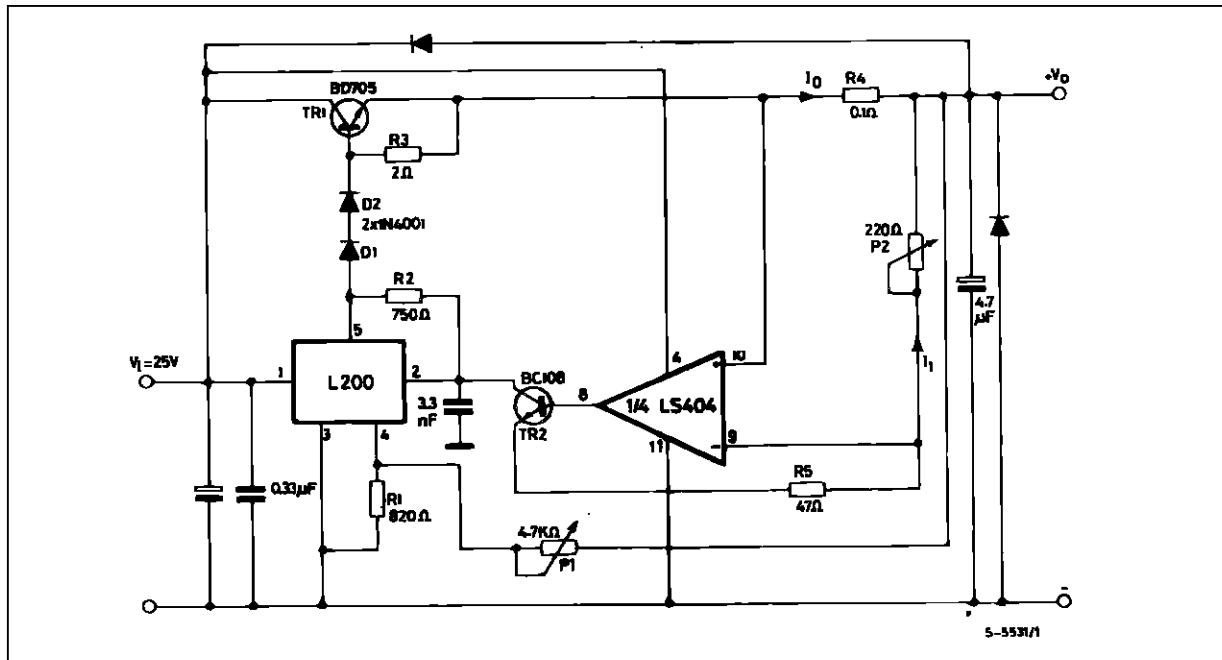

LAYOUT CONSIDERATIONS

The performance of a regulator depends to a great extent on the case with which the printed circuit is produced. There must be no impulsive currents (like the one in the electrolytic filter capacitor at the input of the regulator) between the ground pin of the device (pin 3) and the negative output terminal because these would increase the output ripple. Care must also be taken when inserting the resistor connected between pin 4 and pin 3 of the device.

The track connecting pin 3 to a terminal of this resistor should be very short and must not be crossed

by the load current (which, since it is generally variable, would give rise to a voltage drop on this stretch of track, altering the value of V_{ref} and therefore of V_o).

When the load is not in the immediate proximity of the regulator output "+ sense" and "- sense" terminals should be used (see fig. 37). By connecting the "+ sense" and "- sense" terminals directly at the charge terminals the voltage drop on the connection cable between supply and load are compensated. Fig. 37 shows how to connect supply and load using the sensing clamps terminals.

Figure 37.

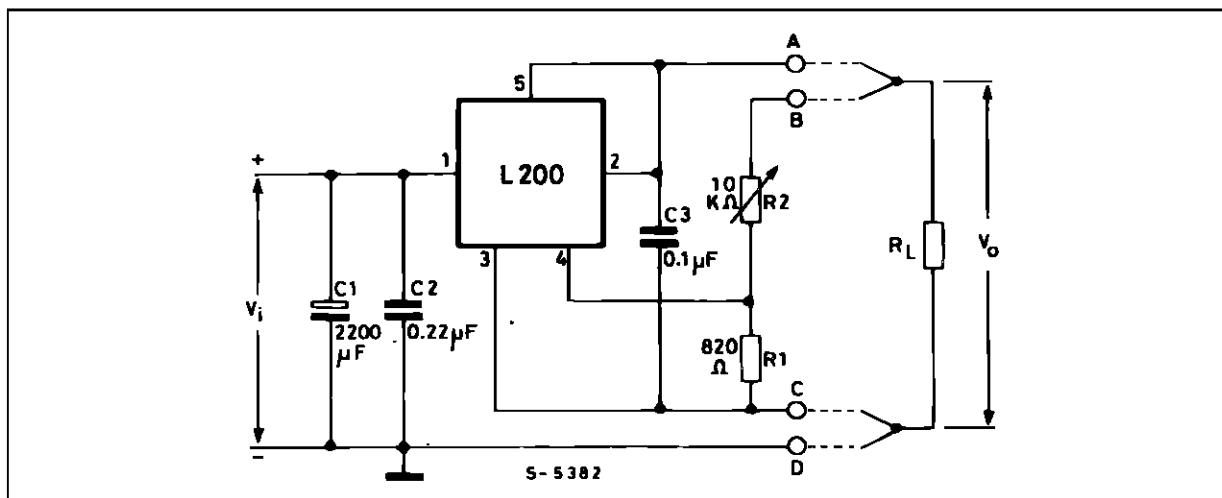

APPLICATION NOTE

Figure 38.

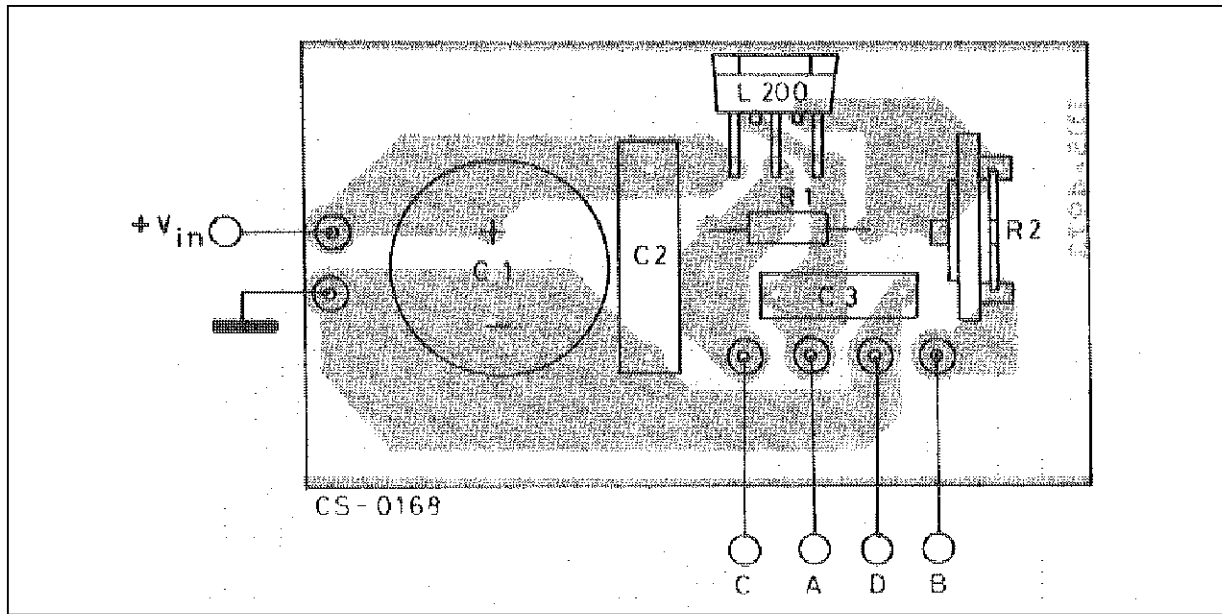

HEATSINK DIMENSIONING

The heatsink dissipates the heat produced by the device to prevent the internal temperature from reaching a value which could be dangerous for device operation and reliability.

Integrated circuits in plastic packages must never exceed 150 °C even in the worst conditions. This limit has been set because the encapsulating resin has problems of vitrification if subjected to temperatures of more than 150 °C for long periods or of more than 170 °C for short periods (24 h). In any case the temperature accelerates the ageing process and therefore influences the device life; an increase of 10 °C can halve the device life. A well designed heatsink should keep the junction temperature between 90 °C and 110 °C. Fig. 39 shows the structure of a power device. As demonstrated in thermodynamics, a thermal circuit can be considered to be an electrical circuit where R1, 2 represent the thermal resistance of the single elements (expressed in C/W);

Figure 39.

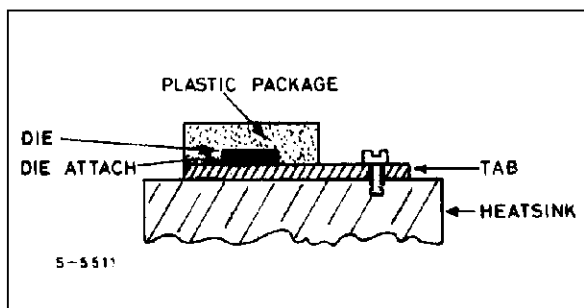
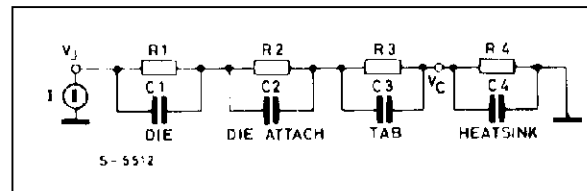

Figure 40.



- C1, 2 the thermal capacitance (expressed in °C/W)
- I the dissipated power
- V the temperature difference with respect to the reference (ground)

This circuit can be simplified as follows :

Figure 41.

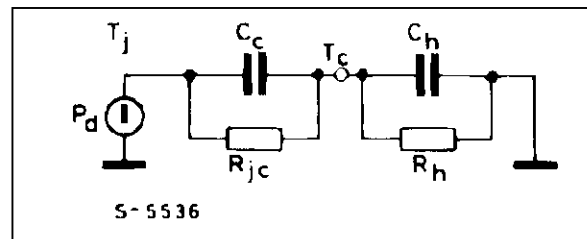

Where C_e is the thermal capacitance of the die plus that of the tab.

- C_h is the thermal capacitance of the heatsink
- R_{jc} is the junction case thermal resistance
- R_h is the heatsink thermal resistance

But since the aim of this section is not that of studying the transistors, the circuit can be further reduced.

Figure 42.

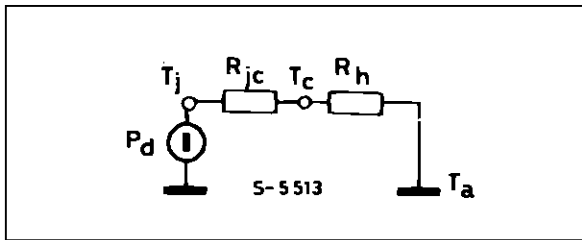

If we now consider the ground potential as ambient temperature, we have :

$$T_j = T_a + (R_{jc} + R_h) P_D \quad (1)$$

$$R_{th} = \frac{T_j - T_a - R_{jc} \cdot P_D}{P_D} \quad (1a)$$

$$T_c = T_a + R_h \cdot P_D \quad (2)$$

For example, consider an application of the L200 with the following characteristics :

$V_{in\ typ} = 20\ V$
 $V_o = 14\ V$
 $I_o\ typ = 1\ A$
 $T_a = 40\ ^\circ C$

typical conditions

$V_{in\ max} = 22\ V$
 $V_o = 14\ V$
 $I_o\ max = 1.2\ A$
 $T_a = 60\ ^\circ C$

overload conditions

$$P_{d\ typ} = (V_{in} - V_o) \cdot I_o = (20 - 14) \cdot 1 = 6\ W$$

$$P_{d\ max} = (22 - 14) \cdot 1.2 = 9.6\ W$$

Imposing $T_j = 90\ ^\circ C$ of (1) we get (from L200 characteristics we get $R_{jc} = 3\ ^\circ C/W$).

$$R_h = \frac{90 - 40 - 3 \cdot 6}{6} = 5.3\ ^\circ C/W$$

Using the value thus obtained in (1), we get that the junction temperature during the overload goes to the following value :

$$T_j = 60 + (3 + 5.3) \cdot 9.6 = 140\ ^\circ C$$

If the overload occurs only rarely and for short periods, dimensioning can be considered to be correct. Obviously during the shortcircuit, the dissipated power reaches much higher values (about 40 W for the case considered) but in this case the thermal protection intervenes to maintain the temperature below the maximum values allowed.

Note 1 : If insulating materials are used between device and heatsink, the thermal contact resistance must be taken into account (0.5 to 1 $^\circ C/W$, depending on the type of insulant used) and the circuit in fig. 43 becomes :

Figure 43.

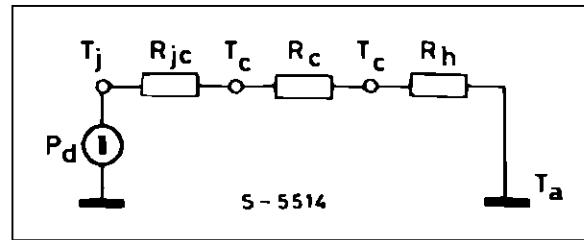

Note 2 : In applications where one or more external transistors are used together with the L200, the dissipated power must be calculated for each component. The various junction temperatures can be calculated by solving the following circuit :

Figure 44.

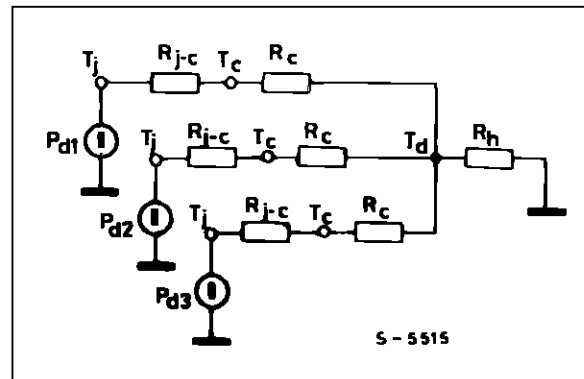

This applies if the various dissipating elements are fairly near to one another with respect to the heatsink dimensions, otherwise the heatsink can no longer be considered as a concentrated constant and the calculation becomes difficult.

This concept is better explained by the graph in fig. 45 which shows the case (and therefore junction) temperature variation as a function of the distance between two dissipating elements with the same type of dissipator and the same dissipated power. The graph in fig. 45 refers to the specific case of two elements dissipating the same power, fixed on a rectangular aluminium plate with a ratio of 3 between the two sides. The temperature jump will depend on the dissipated power and on the device geometry but we want to show that there exists an optimal position between the two devices :

$$d = \frac{1}{2} \cdot \text{side of the plate}$$

Fig. 46 shows the trend of the temperatures as a function of the distance between two dissipating elements

APPLICATION NOTE

ments whose dissipated power is fairly different (ratio 1 to 4).

This graph may be useful in applications with the L200 + external transistor (in which the transistor generally dissipates more than the L200) where the temperature of the L200 has to be kept as low as possible and especially where the thermal protection of the L200 is to be used to limit the transistor

temperature in the case of an overload or abnormal increase in the ambient temperature. In other words the distance between the two elements can be selected so that the power transistor reaches the $T_{j\max}$ (200 °C for a TO-3 transistor) when the L200 reaches the thermal protection intervention temperature.

Figure 45.

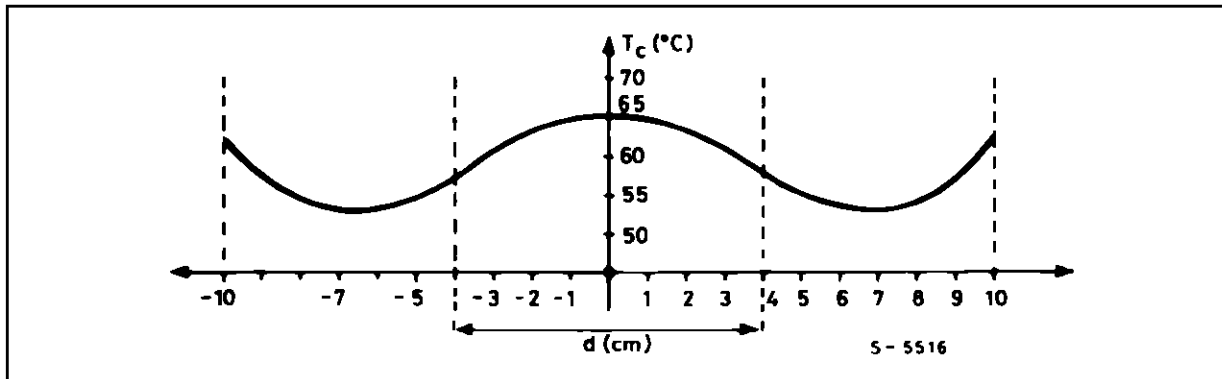
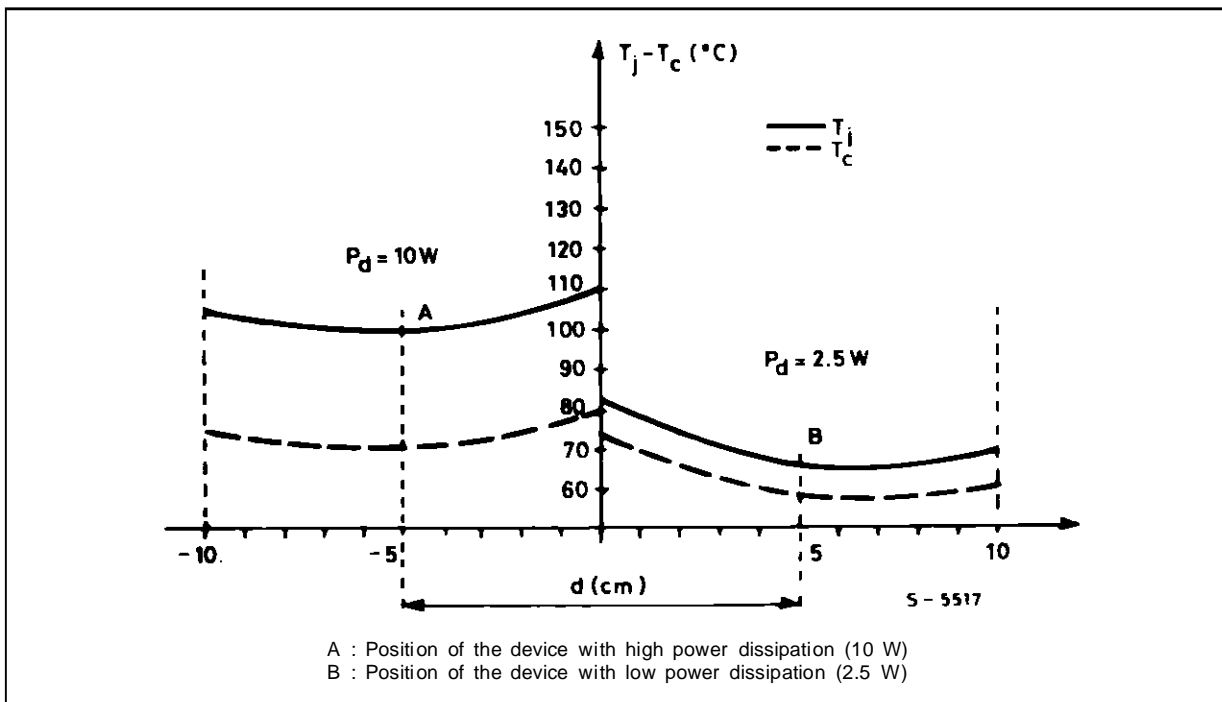

Figure 46.



Information furnished is believed to be accurate and reliable. However, SGS-THOMSON Microelectronics assumes no responsibility for the consequences of use of such information nor for any infringement of patents or other rights of third parties which may result from its use. No license is granted by implication or otherwise under any patent or patent rights of SGS-THOMSON Microelectronics. Specifications mentioned in this publication are subject to change without notice. This publication supersedes and replaces all information previously supplied. SGS-THOMSON Microelectronics products are not authorized for use as critical components in life support devices or systems without express written approval of SGS-THOMSON Microelectronics.

© 1995 SGS-THOMSON Microelectronics - All Rights Reserved

SGS-THOMSON Microelectronics GROUP OF COMPANIES

Australia - Brazil - France - Germany - Hong Kong - Italy - Japan - Korea - Malaysia - Malta - Morocco - The Netherlands - Singapore - Spain - Sweden - Switzerland - Taiwan - Thailand - United Kingdom - U.S.A.



LittleDiode supplies new, hard to find or obsolete electronic components and semiconductors all over the world.

With over two million different components listed you are sure to find the part you need.

Feel free to visit us today at our online store:

LittleDiode.com

Looking forward to providing you with the best possible service.