

LOW DROP VOLTAGE REGULATORS FOR AUTOMOTIVE ELECTRONICS

By S. CISCATO

Linear voltage regulators with an input-output voltage drop of less than 2V are used to ensure continuity of the stabilized output in applications where a battery supply is used. This note describes the characteristics and operation of these devices.

Low drop linear voltage regulators are low voltage (5 to 12V) regulators which are able to provide effective stabilization of the output voltage even when the difference between input voltage and output voltage is less than 2V.

This situation can arise accidentally for a brief period when the main supply source is overloaded. It may also result from a deliberate design decision aimed at reducing the power dissipated in the supply - for example, when the device is used as a post regulator in portable instruments.

Low drop regulators are used widely in automotive applications, a field where integrated circuits have to be particularly rugged. For this reason most low drop devices include protection functions not found in standard regulators. Before describing the SGS THOMSON family of low drop regulators we will therefore begin with a brief description of the automotive electrical environment.

AUTOMOTIVE ENVIRONMENT

In addition to the battery voltage drop during starting, the automotive field presents a number of other serious problems concerning the regulator input voltage : positive and negative high energy / high voltage transients (load dump and field decay), positive and negative low energy/very-high-voltage spikes (switching spikes), battery reversal and battery voltage doubling.

All of these hazards must be withstood by the regulator without damage over an ambient temperature range very close to military standards (- 40 to + 125°C for underhood devices ; - 40 to + 85°C for other devices). Moreover, an output voltage precision of $\pm 4\%$ to $\pm 2\%$ is required over the whole temperature range and in all conditions of input voltage and load current.

BATTERY VOLTAGE DROP

During motor starting the battery is overloaded by a peak current of up to 100A drawn by the starter motor. In this condition, which persists for 20-30ms, the battery voltage drops to about 6V in very cold weather (figure 1).

Figure 1 : Cold Starting Supply Voltage Drop.

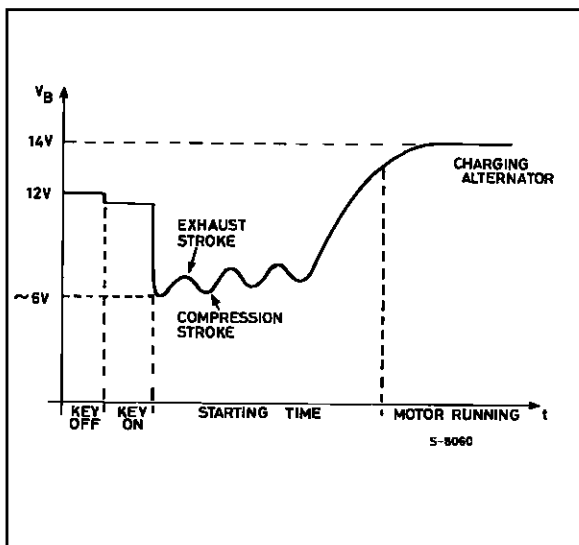

Using standard regulators with a dropout of 1.7V to 2.1V the minimum 4.75V supply necessary for essential functions such as ignition, injection and electronic engine control cannot be guaranteed. Another unfortunate consequence is the loss of RAM memory contents in car radios and trip computers.

A voltage regulator with a voltage drop of less than 1.2V is therefore necessary.

BATTERY VOLTAGE DOUBLING

To aid cold weather starting with a partially flat battery, sometimes two batteries are used in series, doubling the voltage. Regulators must therefore withstand input voltages of 24-26V without disturbing operation.

BATTERY REVERSAL

Voltage regulators must be protected internally against negative input voltages to guard against accidental battery reversal.

LOAD DUMP TRANSIENTS

Load dump transients are high voltage, high energy positive transients.

APPLICATION NOTE

The response time of the output voltage of an alternator to load variations is very long because of the long time constant of the excitation winding and mechanical inertia.

When the load is reduced instantaneously (by turning off lights, cooling fans and so on) the output voltage of the alternator tends to present a positive peak, the amplitude of which depends on the speed of rotation and the excitation current.

During normal operation this does not cause problems because of the high capacity of the battery which, connected in parallel with the alternator output, is able to absorb the transient energy without a significant increase in voltage.

However, motor manufactures impose the standard that electronic devices must be protected against load dump transients because it is possible for the connection between battery and alternator to break.

The worst case voltage peak occurs when the battery-alternator cable is disconnected with the battery discharged and the motor running at its fastest rotation speed. In this case, the load variation is at a maximum and the voltage peak reaches a value comparable with the no-load output of the alternator running at maximum speed with the maximum excitation current.

Figure 2 shows a typical load dump waveform.

Motor manufacturers require that voltage regulators are able to protect themselves and the load against peak voltages of 60 - 100V with an equivalent series resistance of 0.1 to 1 Ω , depending on the type of alternator and external protection device used.

Figure 2 : Load Dump Transient.

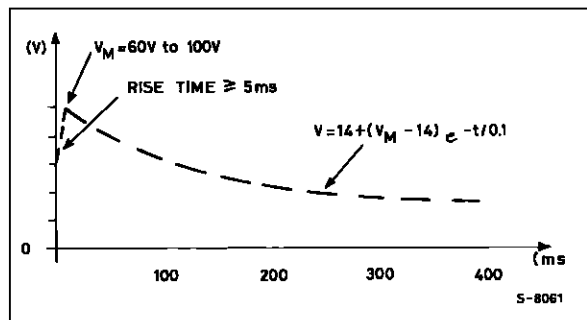

FIELD DECAY TRANSIENTS

Field decay transients are high energy, high voltage negative transients.

If the ignition switch is turned off while current is flowing in inductive loads (electric motors, alternator field coil and so on) a negative voltage transient appears on the supply rail. The peak value in modulo

of this transient is of the same order of magnitude as a load dump transient. In this case, too, the regulator must protect itself and the load.

SWITCHING SPIKES

Windscreen wiper motors, lamp flashers and ignition sparks behave as high frequency noise generators with an equivalent series resistance of 50 to 500 Ω . The energy associated with these transients

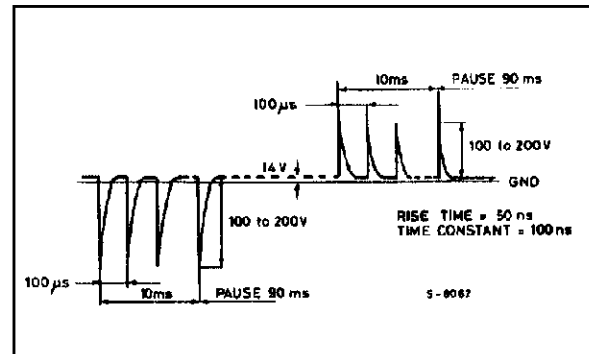

is much lower than load dump or field decay transients but the negative and positive peaks can reach 200V. Figure 3 shows the voltage waveform which the regulators must withstand.

Figure 3 : Switching Spikes.

REGULATOR DESIGN

DROPOUT

The dropout voltage of a linear voltage regulator can be defined for a given output current, I_o , as the minimum difference between input and output voltage below which the output voltage is 100mV lower than the voltage measured at I_o with the nominal input voltage. The current I_o must be specified since the dropout voltage increases as the load current increases.

To obtain a dropout voltage of 0.05 to 1V with an output current of 10 to 50mA, the regulator types L387A, L487, L47XX, L48XX, L4920, L4921, LM2930A and LM2931A are configured with a PNP series-pass transistor as shown in figure 4. The PNP transistor is connected in the common emitter configuration and can therefore operate in saturation, yielding the low dropout voltage desired.

For higher dropout values an NPN series-pass element in emitter follower configuration may be used. This approach, shown in Figure 5, is used in the L2600 series regulators which have a maximum dropout voltage of 1.9V at 500mA.

Figure 4 : PNP Series Pass Transistor in Common Emitter Configuration for very Low Drop Out Voltage Regulators.

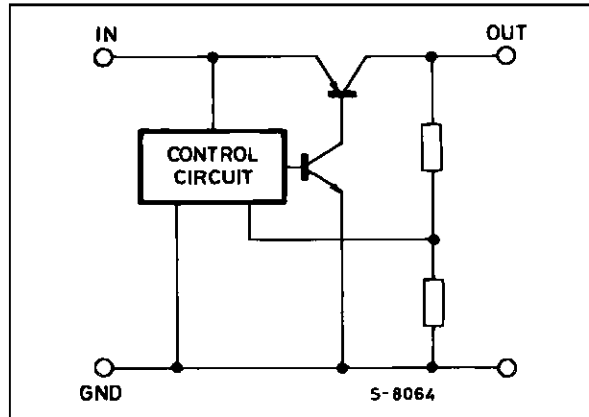
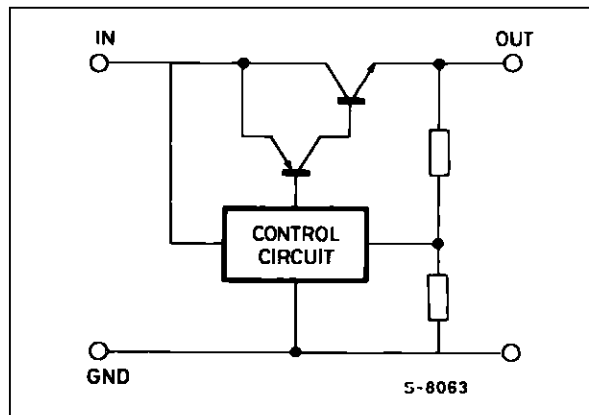

Figure 5 : NPN Series Pass Transistor in Emitter Follower Configuration.



CURRENT CONSUMPTION/QUIESCENT CURRENT

The circuit configurations shown in figures 4 and 5 behave differently as far as concerns the current consumed by the device but not delivered to the load. In the case of figure 5, this current is that necessary for the functioning of the auxiliary circuitry of the regulator (voltage reference, op amp and so on). The base current of the output transistor flows into the load.

In the Figure 4 circuit, in contrast, the base current of the output transistor does not flow through the load and, particularly in saturation, depends heavily on the load current.

Normally lateral PNP transistors are chosen for ICs because they can withstand high positive and negative overvoltages. When negative overvoltages at the input do not occur, or are eliminated by external protection devices, vertical PNP transistors can be used in place of lateral types.

Since vertical PNP transistors have higher gain the current consumed in the regulator is significantly reduced. Vertical PNP transistors will be used in future designs.

VOLTAGE REFERENCE

The wide operating range of input voltage (6 to 26V) and ambient temperature (40 to 125 °C) over which high output voltage precision is required means that a well stabilized voltage reference must be used.

All low drop regulators use bandgap type voltage references (see figure 6). In this structure the two transistors Q₂ and Q₁ have an emitter area ratio of 10 and carry equal collector currents imposed by the current mirror Q₃, Q₄, Q₅. In these conditions the base-emitter voltages of Q₁ and Q₂ differ (at 25 °C) by :

$$V_{BE} = \frac{KT}{q} \ln \frac{A(Q_2)}{A(Q_1)} = 60 \text{ mV}$$

where $\frac{A(Q_2)}{A(Q_1)} = 10$ (emitter area ratio)

$$\frac{KT}{q} = 26 \text{ mV}$$

K = Boltzmann's constant

T = Temperature in Kelvin

q = Charge on an electron

Figure 6 : Bandgap Voltage Reference Circuit in Low Drop Voltage Regulators.

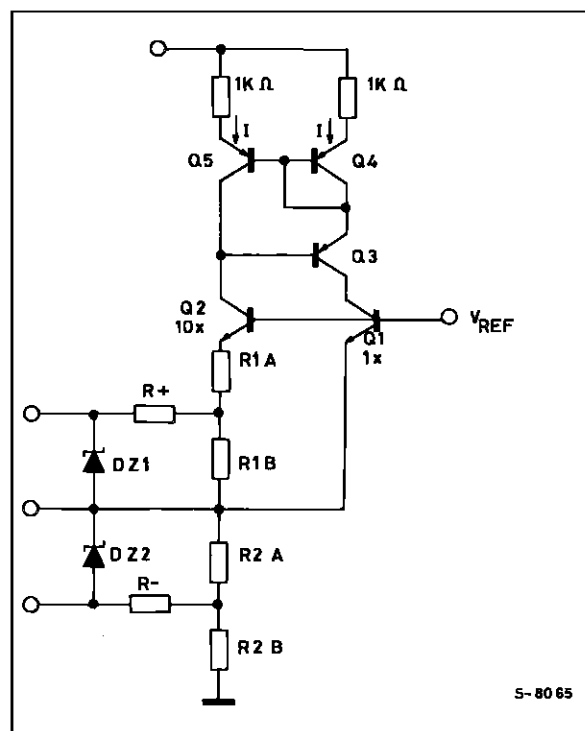

APPLICATION NOTE

The rejection of V_{ref} to variations in the supply voltage is improved by supplying the reference circuit from a stabilized voltage. This is achieved in the L26XX, L48XX, L4920, L4921, LM2930A and LM2931A regulators by means of a preregulator. In the L487, analysing the Figure 6 circuit gives :

$$V_{ref} = V_{BE}(Q_1) + 2 \frac{R_1}{R_2} \Delta V_{BE}(Q_2, Q_1)$$

To maintain V_{ref} constant as temperature varies it

is necessary that $\frac{dV_{ref}}{dT} = 0$ which implies choosing $\frac{R_2}{R_1}$ so that $\frac{2R_2}{R_1} \cdot \frac{60}{T(25^\circ)} + \frac{dV_{BE}(Q_1)}{dT} = 0$

where $T(25^\circ) = 298 \text{ K}$

$\frac{dV_{BE}(Q_1)}{dT} = \text{negative temperature coefficient of}$

the base-emitter voltage.

In L387A and L47XX regulators, in contrast, the supply to the bandgap is switched from the input to the output as soon as the nominal output voltage is reached (figures 7, 8, 9). The variation in output voltage with temperature is shown in figure 10.

Figure 7 : Block Diagram of SGS L2600 Series Regulators.

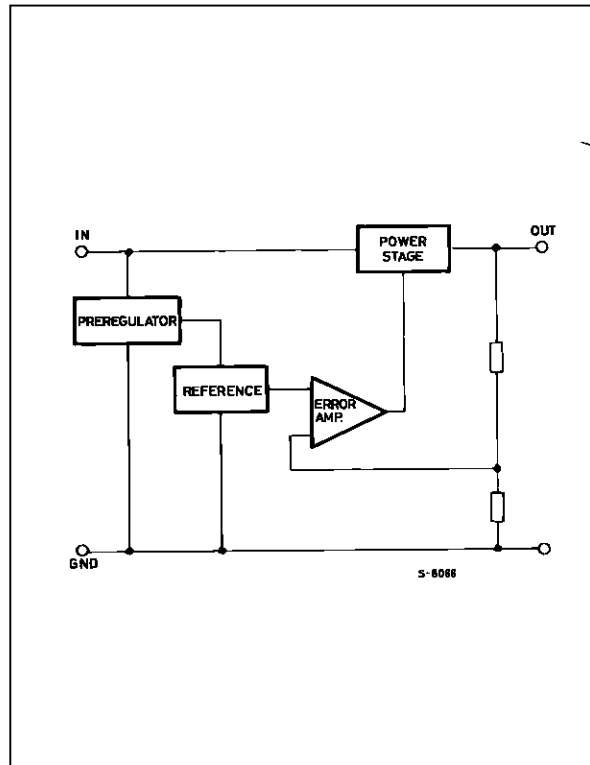

Figure 8 : Block Diagram of L387A and L487 Series Regulators.

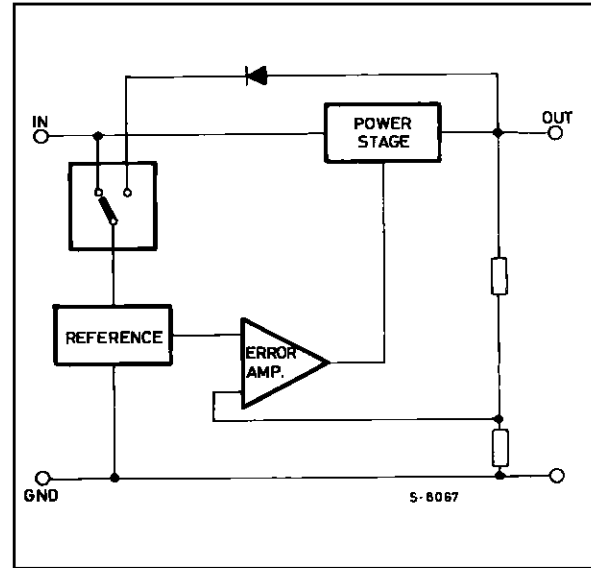

Figure 9 : Block Diagram of LM2930A, LM2931A and L4800 Series Regulators.

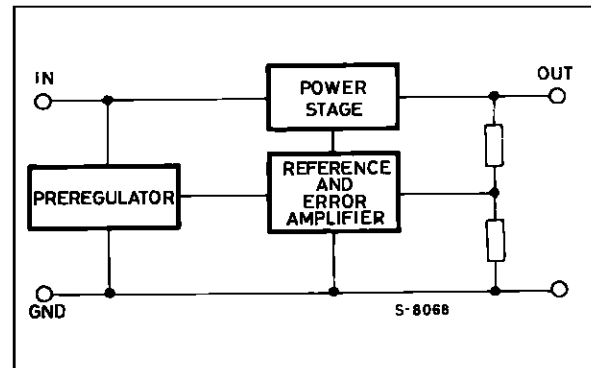
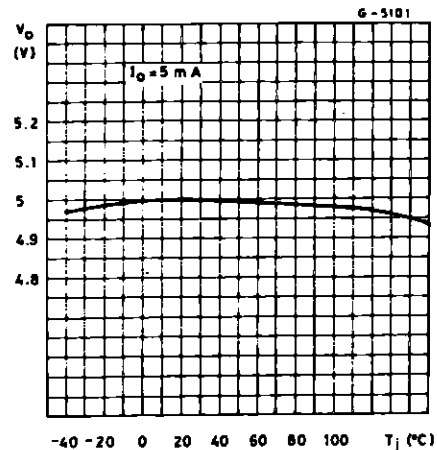

Figure 10 : Outputs Voltage vs. Temperature.



PROTECTION AGAINST HIGH ENERGY TRANSIENTS

To protect the LM2930A, LM2931A, L4920, L4921 and L48XX regulators against high-voltage, high-energy positive transients the basic circuit shown in Figure 11 is used. The zeners in this circuit limit the supply voltage to the maximum operating value and turn off the output stage. The output transistor can thus withstand voltages up to the BV_{CES} , breakdown voltage.

In the other regulators (L487, L387A, L47XX and L26XX) the supply to the internal circuits is also turned off.

The speed of intervention of these protection schemes is fast enough to ensure that the regulator can withstand high energy transients with a rising slope of $10V/\mu s$ without problems, interrupting normal operation only momentarily.

Protection against negative transients is provided by the high series impedance of the possible current paths and the reverse BV_{BEO} breakdown voltage of the lateral PNP transistors (BV_{CBO}).

The breakdown voltages BV_{CES} and BV_{CBO} depend on the technology therefore the transient capability is $\pm 60V$, $\pm 80V$ or $\pm 100V$ for the various types.

Figure 11 : Overvoltage Protection Circuit.

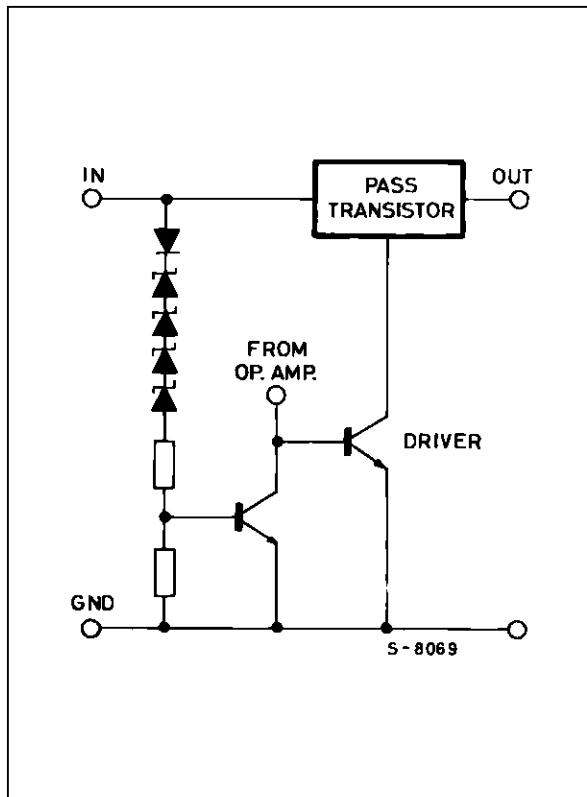

PROTECTION AGAINST LOW ENERGY OVERVOLTAGES

As shown in figure 3, the low energy overvoltages which the devices must resist have very brief rise time and can exceed the breakdown voltages. The protection schemes described above are therefore insufficient. However, since the energy associated with these transients is very low, the regulators can withstand them without problems. Nevertheless it is advisable to place a capacitor of around 100nF at the input.

All of the low drop regulators except the L26XX types need a compensation capacitor at the output. This capacitor also provides extra filtering for low energy transients because it has a low impedance at high frequencies.

Figure 12 : Thermal Protection Circuit.

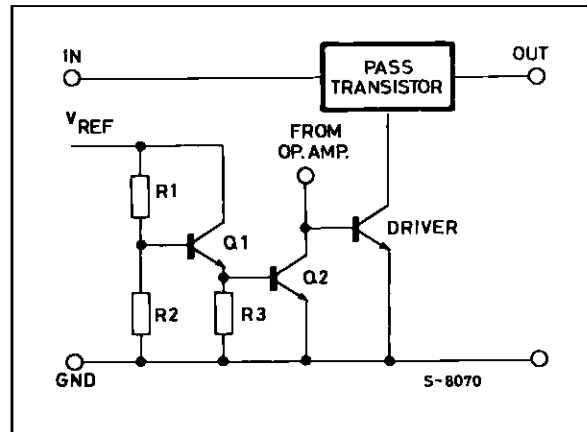

THERMAL PROTECTION

When the junction temperature exceeds the safe maximum for the device a thermal protection circuit (figure 12) holds the output transistor off until the overtemperature condition has passed.

In the figure 12 circuit the resistors R1, R2 and R3 are calculated so that the base voltage of Q1 is 600mV, thus preventing the conduction of Q1 and Q2.

As the junction temperature increases the minimum V_{BE} for conduction of the two transistors fall until, at about $15^{\circ}C$, $2 V_{BE} = 600mV$, the two transistors conduct and Q2 turns off the output transistor driver.

CURRENT PROTECTION

In the L487, L387A and L26XX regulators the output current is limited to its maximum value in the event of a short circuit. A special circuit acts on the base of the output transistor, preventing the output current from exceeding the limit set for the duration of the overload.

APPLICATION NOTE

In the L4920, L4921, LM2930A, LM2931A and L48XX regulators a foldback circuit (figure 13) is used to limit the power dissipated in both the devices and the load in short circuit conditions. The current is limited to a low value (I_{SC}) of about 200 mA as soon as it exceeds the maximum value. The output voltage in this condition reaches a value corresponding to the current I_{SC} flowing through the load.

When the overload condition is removed the output voltage only returns to the nominal load value if the new static load line does not intersect the negative slope region of the curve in figure 13. If it does, the new operating point will be at the intersection.

It is important to note that when power is applied, if the load line intersects the curve in the negative slope region, the regulator will operate with a lower-than-nominal voltage. This can happen with a passive load greater than the normal load (even if it is less than the maximum load I_M) or with active loads such as a current sinker which draw more than I_{SC} even at low voltages (figure 13, curve 3).

Figure 13 : 1) Acceptable Load Line for Turn-on
2) Unacceptable Load Line for Turn-on.

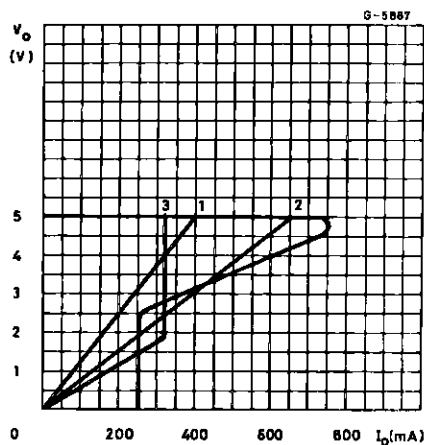

EXTERNAL COMPENSATION

Since the purpose of a voltage regulator is to supply a fixed output voltage in spite of supply and load variations, the open loop gain of the regulator must be very high at low frequencies. This may cause instability as a result of the various poles present in the loop. To avoid this instability dominant pole compensation is used to reduce phase shifts due to other poles at the unity gain frequency. The lower the frequency of these other poles, the greater must be the capacitor used to create the dominant pole for the same DC gain.

Where the output transistor is a lateral PNP type there is a pole in the regulation loop at a frequency too

low to be compensated by a capacitor which can be integrated. For the L487, L47XX, L48XX, L387A, LM2930A and LM2931A external compensation is therefore necessary so a very high value capacitor must be connected from the output to ground.

The parasitic equivalent series resistance of the capacitor used adds a zero to the regulation loop. This zero may compromise the stability of the system since its effect tends to cancel the effect of the pole added. In regulators this ESR must be less than 3Ω and the minimum capacitor value is 47 F (100 μ F for L4800 series).

In the L2600, which uses an NPN power transistor, the stabilization capacitor is small enough to be integrated so no output capacitor is needed. Indeed, if an output capacitor is used it may cause oscillation unless it is greater than 100 μ F, in which case it would itself be the dominant pole. If an electrolytic capacitor of more than 100 μ F is used, a small capacitor must not be added in parallel or with the ESR of the electrolytic it would form another pole, worsening the stability of the system.

TURN-ON WITH CAPACITIVE LOADS

A load which presents a significant capacity between the output and ground (including the external compensation capacitor) will be seen by the regulator as a short circuit when power is applied. The regulator therefore delivers the short circuit current until the load capacitor has been charged to the nominal value.

This factor is extremely important for the dimensioning of the power source. Even a very small DC load can in such cases behave like a maximum load and the power drained from the supply is the sum of the short circuit current delivered to the load and the maximum current consumed in the regulator.

Moreover, as explained above, in regulators with foldback protection the static load line must not cross the negative slope region of figure 13 or the output voltage will not reach the nominal value when power is applied.

SPECIAL FUNCTIONS

RESET

The L387A and L487 include a power on/off reset function which inhibits the operation of circuits supplied by the regulator when the output voltage is too low (4.75V) to guarantee correct operation of logic (figure 14). To avoid malfunctions a delay is also introduced so that the enable signal is only issued some time after the safe output voltage has been reached.

Figure 14 : Reset Timing Waveforms.

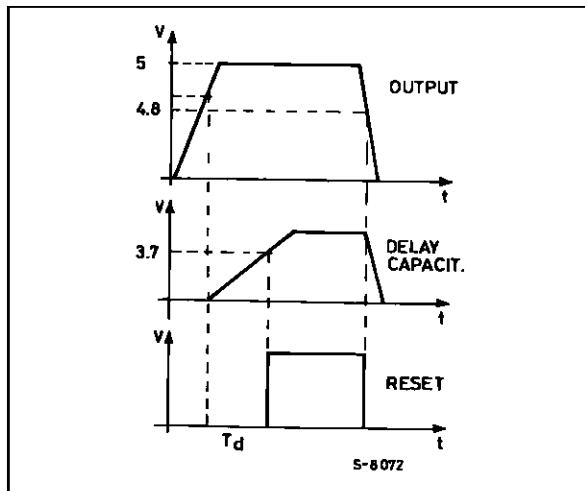

The reset circuitry (figure 15) consists of :

- a comparator connected between the voltage reference and a tap of the output divider, the voltage of which is higher than the feedback voltage ;
- an SCR to memorize any brief glitches in the output voltage that can cause some trouble with the logic.
- a delay circuit with an external capacitor charged by an internal current source

This function has been integrated into the voltage

regulator to exploit the basic advantage of taking information at the source. The use of double calibrations can thus be avoided.

For the correct operation of the reset function, two basic relations must be satisfied in all cases

$$V_{res\ max} < V_{out\ min} \tag{1}$$

$$V_{res\ min} > 4.75\ V \tag{2}$$

where $V_{res\ max}/V_{res\ min}$ are maximum/minimum value for the reset signal going high-low.

(1) means that the RESET signal must be high when the device is regulating

(2) means that the RESET signal must be low when the output voltage goes under 95 % of the nominal (5V). Expressions (1) and (2) can be rewritten as :

$$(V_{res\ max} - V_{res\ min}) + (V_{nom} - V_{out\ min}) < V_{nom} \cdot 4.75\% \tag{3}$$

This means that the sum of all the errors in the worst case must be less than 5 % (250mV).

- absolute spread of the reference
- error due to the load regulation (1 % max)
- error due to the offset of the reset comparator and error amplifier (0.5 %)
- errors due to the output divider (0.5 %)
- hysteresis of the comparator to speed up the transitions (50mV that is 1 % referred to 5V output)

Figure 15 : Schematic Block Diagram of a Voltage Regulator with Reset Function.

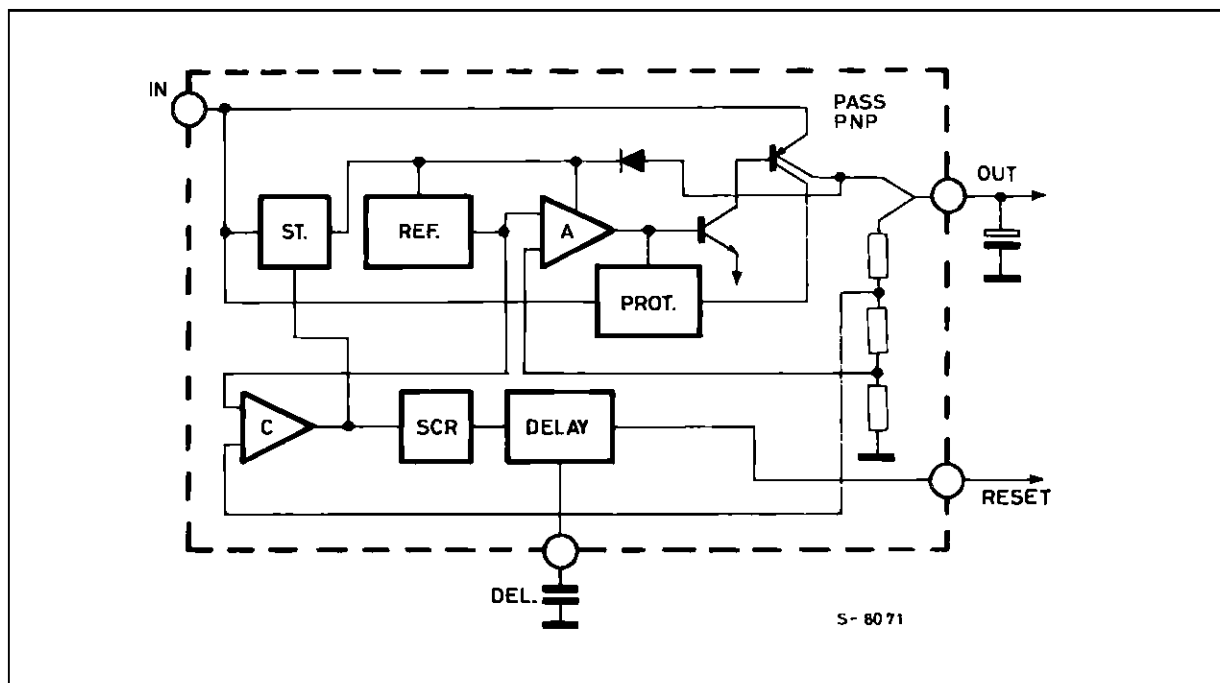

APPLICATION NOTE

VARIABLE OUTPUT VOLTAGE

The L4920 and L4921 are structurally identical to L48XX series regulators except that the voltage divider in the feedback loop is available externally (figure 16). The output voltage can therefore be varied from 1.25V (the reference voltage) to 20V. It should be noted, however, that the minimum input voltage is 5.1V for operation with output voltages below 4.5V

(otherwise the internal circuits will not work). For output voltages above 4.5V the input voltage must be at least equal to the output voltage plus the dropout voltage. The L4920 and L4921 are therefore low dropout regulators only for voltages above 4.5V.

A value of 6 K Ω is recommended for R2 to match the internal circuitry.

Figure 16 : The L4920 and L4921 are Structurally Identical to L48XX Series Regulators Except that the Voltage Divider in the Feedback Loop is Available Externally.

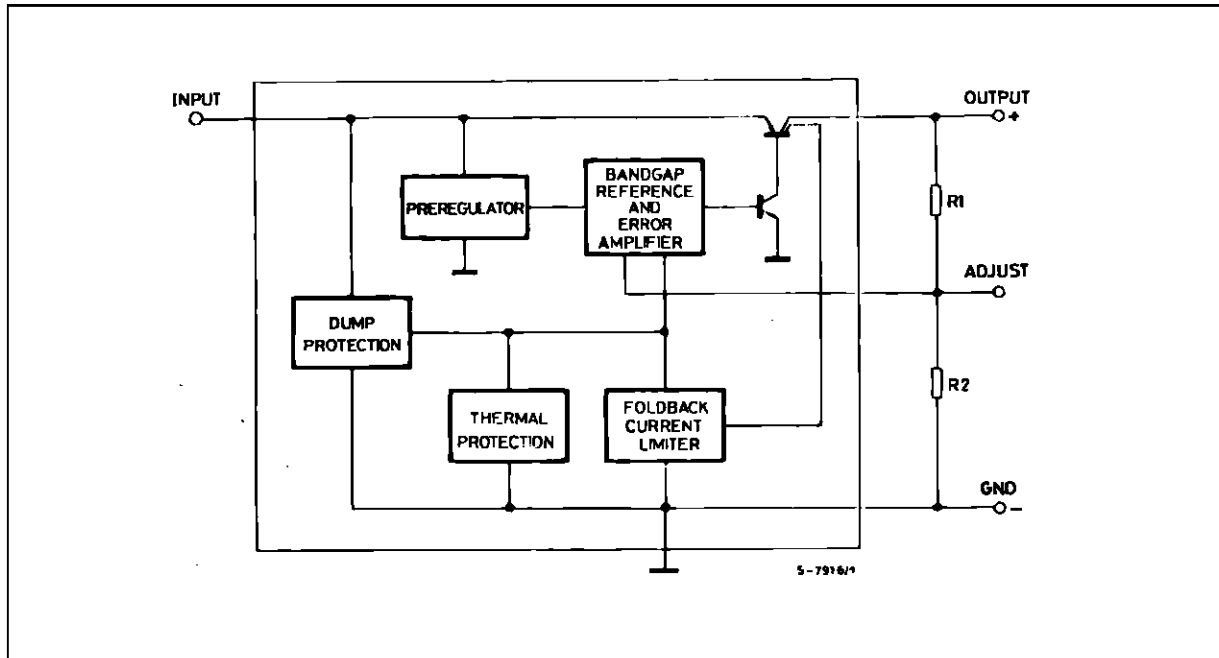

Information furnished is believed to be accurate and reliable. However, SGS-THOMSON Microelectronics assumes no responsibility for the consequences of use of such information nor for any infringement of patents or other rights of third parties which may result from its use. No license is granted by implication or otherwise under any patent or patent rights of SGS-THOMSON Microelectronics. Specifications mentioned in this publication are subject to change without notice. This publication supersedes and replaces all information previously supplied. SGS-THOMSON Microelectronics products are not authorized for use as critical components in life support devices or systems without express written approval of SGS-THOMSON Microelectronics.

© 1995 SGS-THOMSON Microelectronics - All Rights Reserved

SGS-THOMSON Microelectronics GROUP OF COMPANIES

Australia - Brazil - France - Germany - Hong Kong - Italy - Japan - Korea - Malaysia - Malta - Morocco - The Netherlands - Singapore - Spain - Sweden - Switzerland - Taiwan - Thailand - United Kingdom - U.S.A.



LittleDiode supplies new, hard to find or obsolete electronic components and semiconductors all over the world.

With over two million different components listed you are sure to find the part you need.

Feel free to visit us today at our online store:

LittleDiode.com

Looking forward to providing you with the best possible service.