

Application Note

AN2532/D
Rev. 0, 5/2003

Standard Space Vector
Modulation – 3 outputs
version TPU Function Set
(svmStd3)



By Milan Brejl, Ph.D.

Functional Overview

Standard Space Vector Modulation – 3 outputs version (svmStd3) is a variant of the svmStd function that, in contrary to svmStd, generates only top channel signal of each PWM pair. The bottom channel signal could be derived from the top channel signal by an external hardware. The function set consists of 4 TPU functions:

- Standard Space Vector Modulation – 3 outputs version (svmStd3)
- Synchronization signal for Standard Space Vector Modulation – 3 outputs version (svmStd3_sync)
- Resolver Reference Signal for Standard Space Vector Modulation – 3 outputs version (svmStd3_res)
- Fault Input for Standard Space Vector Modulation – 3 outputs version (svmStd3_fault)

The svmStd3 TPU function generates a 3-channel 3-phase center-aligned PWM signal. The generated signals control external hardware, which outputs pair of transistor signals (top and bottom) with dead-time inserted.

The Synchronization Signal for the svmStd3 function can be used to generate one or more adjustable signals for a wide range of uses, which are synchronized to

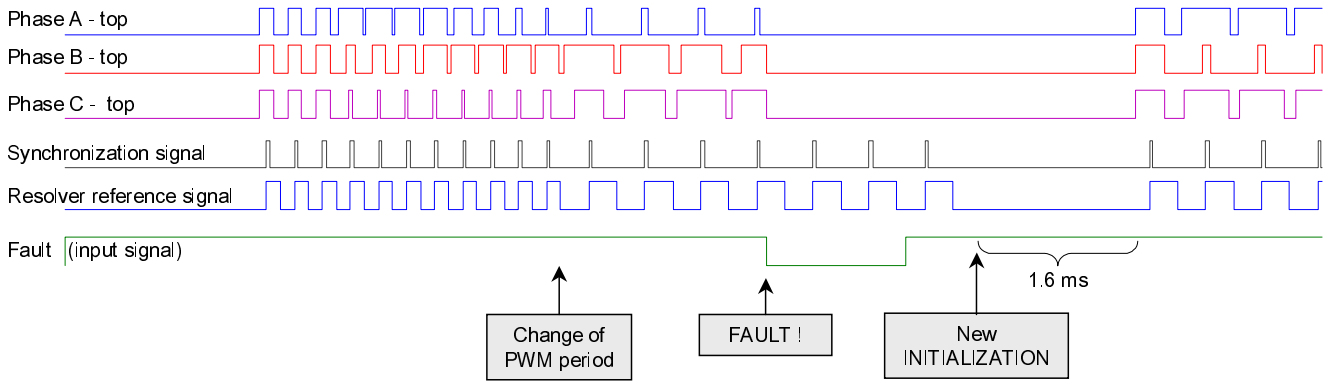

Figure 1. Signals generated by svmStd3 TPU function set

the PWM, and track changes in the PWM period. The Resolver Reference Signal for svmStd3 function can be used to generate one or more 50% duty-cycle adjustable signals that are also synchronized to the PWM. The Fault Input for the svmStd3 function is a TPU input function that sets all PWM outputs low when the input signal goes low. See [Figure 1](#).

Function Set Configuration

The Standard Space Vector Modulation – 3 outputs version TPU function is the main function of the set. It can be used either alone, with some of the supporting functions, or with all of them. One or more channels running a Synchronization Signal for svmStd3 as well as Resolver Reference Signals for svmStd3 functions can be added to the main svmStd3 function. Each channel can run with different settings. When the Fault Input for svmStd3 is added, it is recommended to use it on channel 15, and to select the hardware option that disables all TPU output pins when the channel 15 input signal is low (DTPU bit = 1). This ensures that the hardware reacts quickly to a pin fault state. Note that it is not only the PWM channels, but all TPU output channels including the synchronization signals, that are disabled in this configuration.

[Table 1](#) shows the configuration options and restrictions.

Table 1. svmStd3 TPU function set configuration options and restrictions

TPU function	Optional/ Mandatory	How many channels	Assignable channels
svmStd3_fault	optional	1	any, recommended is 15 and DTTPU bit set

Table 2 shows an example of configuration.

Table 2. Example of configuration

Channel	TPU function	Priority
0	svmStd3	high
1	svmStd3	high
2	svmStd3	high
10	svmStd3_sync	low
11	svmStd3_res	low
15	svmStd3_fault	high

Table 3 shows the TPU function code sizes.

Table 3. TPU function code sizes

TPU function	Code size
svmStd3	176 μ instructions + 8 entries = 184 long words
svmStd3_sync	26 μ instructions + 8 entries = 34 long words
svmStd3_res	38 μ instructions + 8 entries = 46 long words
svmStd3_fault	9 μ instructions + 8 entries = 17 long words

Configuration Order

The CPU configures the TPU as follows.

1. Disables the channels by clearing the two channel priority bits on each channel used (not necessary after reset).
2. Selects the channel functions on all used channels by writing the function numbers to the channel function select bits.
3. Initializes function parameters. The parameters *T*, *prescaler*, *MPW*, *SQRT3* and *sync_presc_addr* must be set before initialization. If an svmStd3_sync channel or an svmStd3_res channel is used, then also its parameters must be set before initialization.
4. Issues an HSR (Host Service Request) type %10 to one of the svmStd3 channels to initialize all PWM channels. Issues an HSR type %10 to the svmStd3_sync channels, svmStd3_res channels and svmStd3_fault channel, if used.

5. Enables servicing by assigning high, middle or low priority to the channel priority bits. All PWM channels must be assigned the same priority to ensure correct operation. The CPU must ensure that the svmStd3_sync or svmStd3_res channels are initialized after the initialization of PWM channels:
 - assign a priority to the PWM channels to enable their initialization
 - if a Synchronization Signal or a Resolver Reference Signal channel is used, wait until the HSR bits are cleared to indicate that initialization of the PWM channels has completed and
 - assign a priority to the svmStd3_sync or svmStd3_res channels to enable their initialization

NOTE: A CPU routine that configures the TPU is generated automatically using MPC500_Quick_Start Graphical Configuration Tool.

Detailed Function Description

Standard Space Vector Modulation – 3 outputs version (svmStd3)

The svmStd3 TPU function generates a 3-channel, 3-phase PWM signal. Unlike svmStd, the generated signals are not top-bottom pairs with dead-times but only top-like signals without dead-times. In order to charge the bootstrap transistors, the PWM signals start to run 1.6ms after their initialization (at 20MHz TCR1 clock). The function generates signals corresponding to a Reference Voltage Vector Amplitude of 0 (50% duty-cycle) until the first reloaded values are processed.

The CPU controls the PWM output by setting the TPU parameters. The Stator Reference Voltage Vector components u_a and u_b have to be adjusted during run time. The PWM period T and the *prescaler* – the number of PWM periods per reload of new values – are also read at each reload, so these parameters can be changed during run time. Conversely, minimum pulse width (*MPW*) is not supposed to be changed during run time. The CPU notifies the TPU that the new reload values are prepared by setting the LD_OK parameter. The TPU notifies the CPU that the reload values have been read and new values can be written by clearing the LD_OK parameter.

The TPU writes the parameter Sector that indicates the current Stator Reference Voltage Vector position in sector 1 to 6.

The following figures show the input Stator Reference Voltage Vector components $u_{\hat{\alpha}}$ and $u_{\hat{\beta}}$, corresponding sectors and output PWM signal duty cycle ratios:

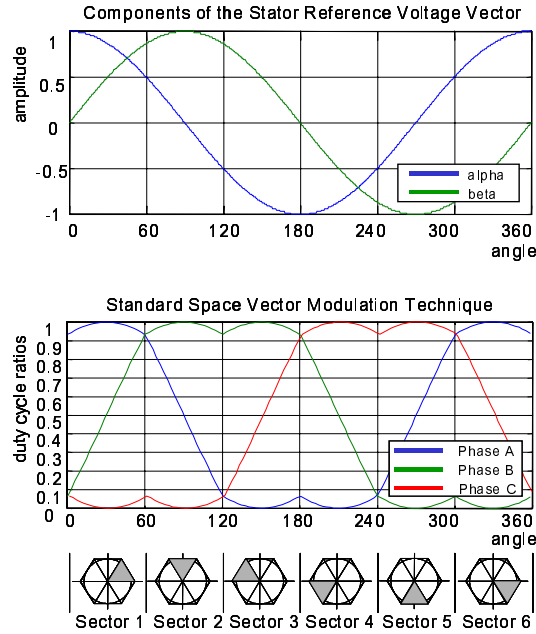

Figure 2. Standard Space Vector Modulation – 3 outputs version Technique

The following equations describe how the Space Vector Modulation PWM signal high-times ht_A , ht_B , ht_C and transition times $t_{low-high}$ and $t_{high-low}$ of each channel are calculated:

$$U_{\beta} = T \cdot u_{\beta}$$

$$U_{\alpha} = T \cdot u_{\alpha}$$

$$X = U_{\beta}$$

$$Y = \frac{U_{\beta} + U_{\alpha} \sqrt{3}}{2}$$

$$Z = \frac{U_{\beta} - U_{\alpha} \sqrt{3}}{2}$$

	Y < 0		Y >= 0		
	Z < 0	Z >= 0	Z < 0	Z >= 0	
		X <= 0	X > 0	X <= 0	X > 0
Sector:	V.	IV.	III.	VI.	I.
				I.	II.

Sector I., IV.: $ht_A = \frac{T+X-Z}{2}$
 $ht_B = \frac{T+X+Z}{2} = t_A + Z$
 $ht_C = \frac{T-X+Z}{2} = t_B - X$

Sector II., V.: $ht_A = \frac{T+Y-Z}{2}$
 $ht_B = \frac{T+Y+Z}{2} = t_A + Z$
 $ht_C = \frac{T-Y-Z}{2} = t_A - Y$

Sector III., VI.: $ht_A = \frac{T-X+Y}{2}$
 $ht_B = \frac{T+X-Y}{2} = t_C + X$
 $ht_C = \frac{T-X-Y}{2} = t_A - Y$

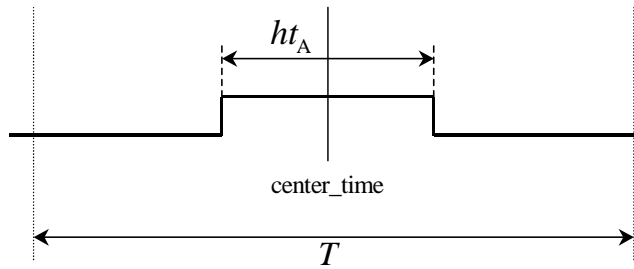

Phase A:

$$t_{low-high} = center_time - \frac{ht_A}{2}$$

$$t_{high-low} = center_time + \frac{ht_A}{2}$$

Phase B and Phase C similarly with ht_B and ht_C substituted to ht_A .

Host Interface

- Written By CPU
- Written by both CPU and TPU
- Written By TPU
- Not Used

Table 4. svmStd3 Control Bits

Name	Options
<div style="display: flex; justify-content: space-around; font-size: small;"> 3210 </div> <div style="display: flex; align-items: center; margin-top: 5px;"> <div style="border: 1px solid black; width: 20px; height: 20px; margin-right: 5px;"></div> <div style="border: 1px solid black; width: 20px; height: 20px; margin-right: 5px;"></div> <div style="border: 1px solid black; width: 20px; height: 20px; margin-right: 5px;"></div> <div style="border: 1px solid black; width: 20px; height: 20px;"></div> Channel Function Select </div>	svmStd3 function number (Assigned during assembly the DPTRAM code from library TPU functions)

Table 4. svmStd3 Control Bits

Name	Options
<div style="display: flex; align-items: center;"> <div style="margin-right: 10px;"> <div style="display: flex; justify-content: space-between; width: 20px; height: 20px; border: 1px solid black; margin-bottom: 2px;">1</div> <div style="display: flex; justify-content: space-between; width: 20px; height: 20px; border: 1px solid black;">0</div> </div> <div>Channel Priority</div> </div>	00 – Channel Disabled 01 – Low Priority 10 – Middle Priority 11 – High Priority
<div style="display: flex; align-items: center;"> <div style="margin-right: 10px;"> <div style="display: flex; justify-content: space-between; width: 20px; height: 20px; border: 1px solid black; margin-bottom: 2px;">1</div> <div style="display: flex; justify-content: space-between; width: 20px; height: 20px; border: 1px solid black;">0</div> </div> <div>Host Service Bits (HSR)</div> </div>	00 – No Host Service Request 01 – Not used 10 – Initialization 11 – Stop
<div style="display: flex; align-items: center;"> <div style="margin-right: 10px;"> <div style="display: flex; justify-content: space-between; width: 20px; height: 20px; background-color: green; margin-bottom: 2px;">1</div> <div style="display: flex; justify-content: space-between; width: 20px; height: 20px; background-color: green;">0</div> </div> <div>Host Sequence Bits (HSQ)</div> </div>	xx – Not used
<div style="display: flex; align-items: center;"> <div style="margin-right: 10px;"> <div style="display: flex; justify-content: space-between; width: 20px; height: 20px; border: 1px solid black; margin-bottom: 2px;">0</div> </div> <div>Channel Interrupt Enable</div> </div>	0 – Channel Interrupt Disabled 1 – Channel Interrupt Enabled
<div style="display: flex; align-items: center;"> <div style="margin-right: 10px;"> <div style="display: flex; justify-content: space-between; width: 20px; height: 20px; background-color: blue; margin-bottom: 2px;">0</div> </div> <div>Channel Interrupt Status</div> </div>	0 – Interrupt Not Asserted 1 – Interrupt Asserted

TPU function svmStd3 generates an interrupt when the current values of *Ualfa*, *Ubeta*, *T* and *prescaler* have been read by the TPU and indicates to the CPU that it can write new variables. The CPU program can either wait for this interrupt to occur, or poll the *LD_OK* bit to check it has cleared. The interrupt is generated at each reload by one of the PWM channels.

Table 5. svmStd3 Parameter RAM

Channel	Parameter	15	14	13	12	11	10	9	8	7	6	5	4	3	2	1	0	
Phase A	0	htA																
	1	HLtime_A																
	2	center_time																
	3	LD_OK																
	4	SQRT3																
	5	MPW																
	6	UA3																
	7	fault_pinstate																
Phase B	0	htB																
	1	HLtime_B																
	2	UA																
	3	UB																
	4	Ualfa																
	5	Ubeta																
	6	Sector																
	7	max_ht																

Table 5. svmStd3 Parameter RAM

Channel	Parameter	15	14	13	12	11	10	9	8	7	6	5	4	3	2	1	0	
Phase C	0	htC																
	1	HLtime_C																
	2	T_copy																
	3	dec																
	4	T																
	5	prescaler																
	6	prsc_copy																
	7	sync_presc_addr																

Table 6. svmStd3 parameter description

Parameter	Format	Description
Parameters written by CPU		
Ualfa, Ubeta	16-bit fractional	Stator Reference Voltage Vector components
T	16-bit unsigned integer	PWM period in number of TCR1 TPU cycles
prescaler	16-bit unsigned integer	The number of PWM periods per reload of new values
MPW	16-bit unsigned integer	Minimum pulse width in number of TCR1 TPU cycles. See Performance for details.
SQRT3	16-bit fractional	$\sqrt{3}/2 = 0.866 = \$6EDA$ constant
sync_presc_addr	8-bit unsigned integer	address of synchronization channel <i>prescaler</i> parameter: $\$X4$, where X is synchronization channel number. $\$0$ if no synchronization channel is used.
Parameters written by both TPU and CPU		
LD_OK	1-bit	0 ... CPU can update variables 1 ... TPU can read variables CPU sets 1, TPU sets 0
Parameters written by TPU		
Sector	16-bit unsigned integer	The position of Stator Reference Voltage Vector in a sector. The Sector can be 1, 2, 3, 4, 5 or 6
fault_pinstate	0 or 1	If fault channel is used, state of fault pin: 0 ... low 1 ... high
Other parameters are just for TPU function inner use.		

Performance

Table 7. svmStd3 State Statistics

State	Max IMB Clock Cycles	RAM Accesses by TPU
INIT	66	19
STOP	20	0
LH	26	5
HL	2	1
HL_RLD	44	16
C1	48	3
C2	48	4
C3	50	3
C4	48	8

NOTE: Execution times do not include the time slot transition time ($TST = 10$ or 14 IMB clocks)

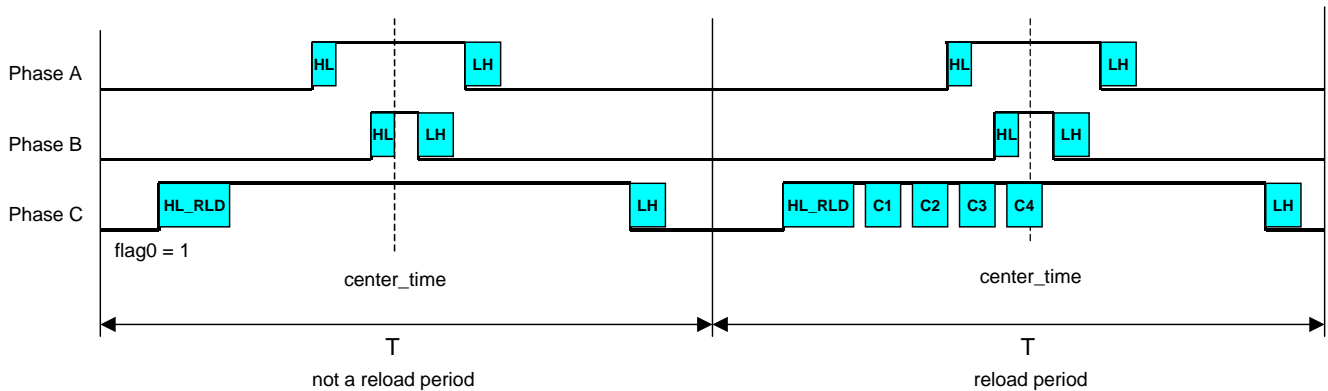

Figure 3. svmStd3 timing

NOTE: The channel with longest momentary high-time is marked by a flag0 and runs the HL_RLD and C1, C2, C3, C4 states.

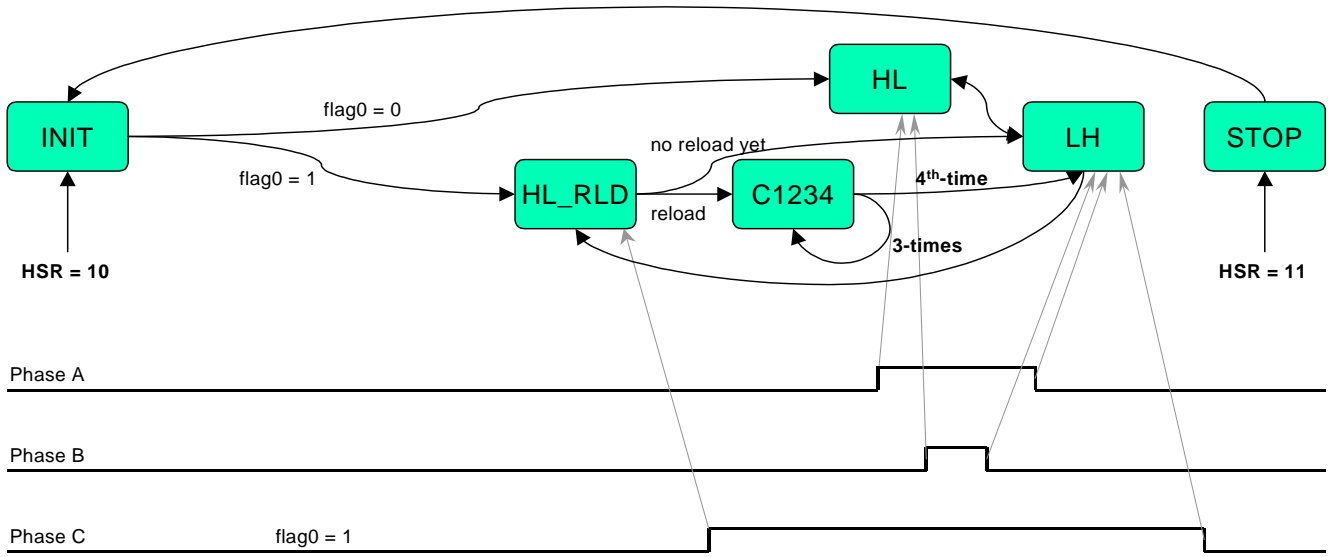

Figure 4. svmStd3 state diagram

Minimum Pulse Width

The TPU cannot generate PWM signals with duty cycle ratios very close to 0% or 100%. The minimum pulse width that the TPU can be guaranteed to generate correctly is determined by the TPU function itself and by the activity on the other channels. When the TPU function is requested to generate a narrower pulse a collision can occur. To prevent this, the parameter *MPW* (minimum pulse width) is introduced. The TPU function svmStd3 limits the narrowest generated pulse widths to *MPW*. The CPU program should check, and limit, the maximum amplitude of the Stator Reference Voltage Vector before decomposition to $u_{\hat{a}}$, $u_{\hat{a}}$ components. The maximum amplitude of the Stator Reference Voltage Vector should be less than

$$1 - \frac{2 MPW}{T}$$

If this is not the case, the TPU function will start to limit the minimum pulse widths to *MPW* to prevent a collision, and the duty cycle ratio traces will be deformed as shown on [Figure 5](#).

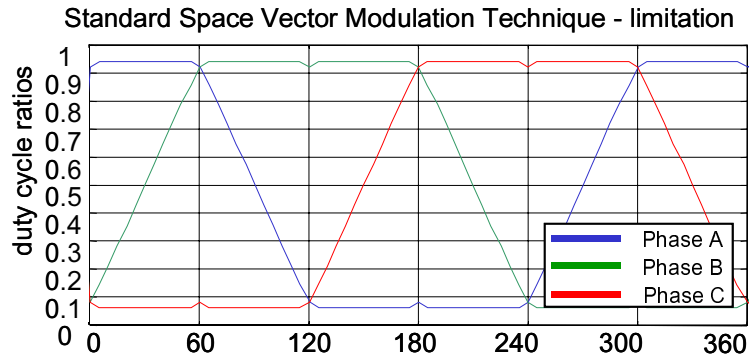

Figure 5. Effect of limitation

The *MPW* is written by the CPU. The *MPW* depends on the whole TPU unit configuration, especially the lengths of the longest states of other functions, and their priorities, running on the same TPU. The *MPW* has to be correctly calculated at the time the whole TPU unit is configured.

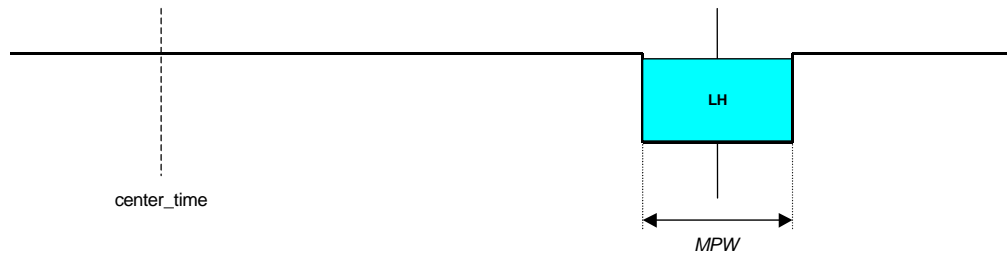

Figure 6. Timing of the worst case

When *svmStd3* is running alone on one TPU, the minimum pulse width can be calculated according to **Figure 6**. This illustrates the worst case timing. The high to low transition runs the LH state that sets the following low to high transition. The LH state lasts 26 IMB clock cycles (see **Table 7**). Each state is preceded by the Time Slot Transition (TST), which takes 10 or 14 IMB clock cycles. So the time necessary to set the next transition, that corresponds to *MPW*, is 40 IMB clock cycles .

Note that the *MPW* is not entered into the parameter RAM in IMB clock cycles, but in TCR1 clock cycles. It is recommended for the *svmStd3* function, that the TCR1 clock is configured for its maximum speed, which is the IMB clock divided by 2. In this case the *MPW* = 20.

When other functions are running together, on the same TPU, with the svmStd3 functions, a latency between the high-low transition and the start of the LH state can appear. To maintain sufficiently high performance of svmStd3, it is recommended that the following rules are followed to configure the TPU:

- assign svmStd3 PWM channels high priority
- assign svmStd3 PWM functions on low channel numbers so that no other function with high priority is assigned a channel with a lower number

In this instance, the worst case timing case that can happen is illustrated in Figure 7.

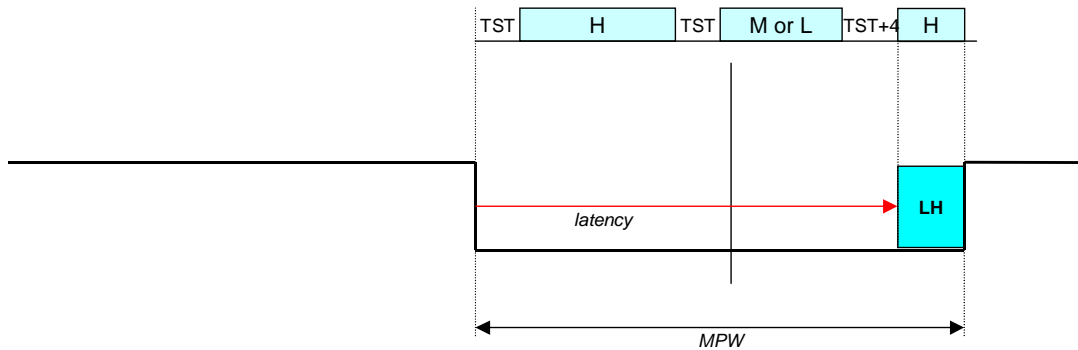

Figure 7. Worst case timing

The time slot sequences at the top of the figure shows when a state of a high (H), middle (M) or low (L) priority is serviced in the worst case. To calculate the MPW follow these steps:

- Get the lengths of the longest states.
 - It is necessary to know the lengths of the longest states within all functions of each priority group. The initialization states are not considered – only the running states. Let's denote H as the time period of the longest state within all functions running on high priority (Do not consider svmStd3 functions). Let's denote M as the time period of the longest state within all functions running on middle priority and L as the time period of the longest state within all functions running on low priority.
- Calculate MPW according to Figure 7.
 - $TST + H + TST + \max(M,L) + TST+4 + LH$
that is $60 + H + \max(M,L)$ IMB clock cycles.

$$MPW \text{ (in IMB clock cycles)} = 60 + H + \max(M,L)$$

- Convert *MPW* in IMB clock cycles to *MPW* in TCR1 clock cycles based on TCR1 prescaler settings.

When there are no channels of middle or low priority, simply leave out all the *H* or *L* and the following TST or TST+4 from the formulas.

When the recommended configuration rules are not adhered to, the timing of the worst case is much more complicated. It requires some familiarity with the details of the TPU priority scheme. In this case, the Worst-Case Latency (WCL), which is automatically calculated by the MPC500_Quick_Start Graphical Configuration Tool, can serve as a good approximation. This is always longer than the real-case is. Let the WCL be calculated after the configuration of the TPU channels and then find the longest WCL value within all *svmStd3* PWM channels. Convert the number, from IMB clock cycles to TCR1 clock cycles, to get the *MPW*.

Synchronization signal for Standard Space Vector Modulation – 3 outputs version (svmStd3_sync)

The *svmStd3_sync* TPU function uses information obtained from the *svmStd3* PWM functions, the actual PWM center times and the PWM periods. This allows a signal to be generated, which tracks the changes in the PWM period and is always synchronized with the PWM. The synchronization signal is a positive pulse generated repeatedly after the *prescaler* or *presc_copy* PWM periods (see next paragraph). The low to high transition of the pulse can be adjusted by a parameter, either negative or positive, to go a number of TCR1 TPU cycles before or after the PWM period center time. The pulse width *pw* is another synchronization signal parameter.

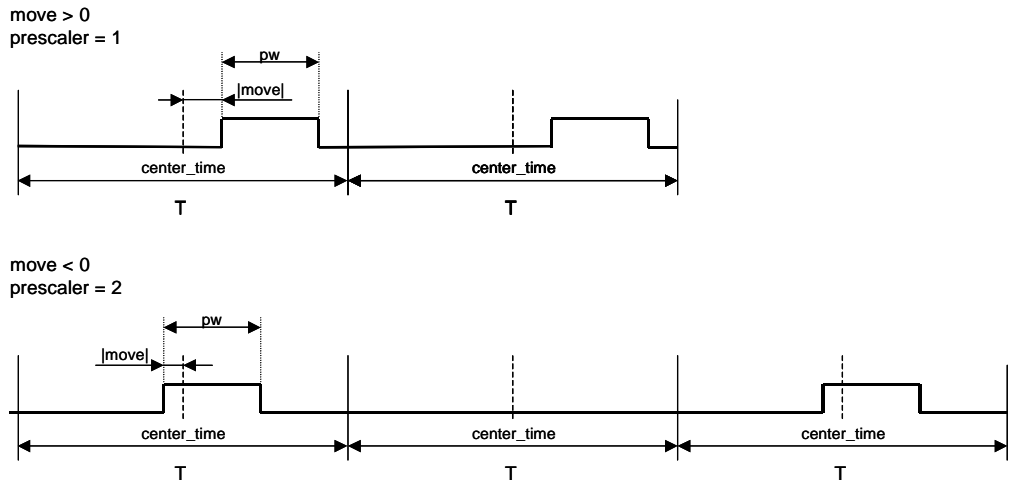

Figure 8. Synchronization signal adjustment examples

Synchronized Change of PWM Prescaler And Synchronization Signal Prescaler

The svmStd3_sync TPU function actually uses the *presc_copy* parameter instead of the *prescaler* parameter. The *prescaler* parameter holds the prescaler value that is copied to the *presc_copy* by the svmStd3_bottom function at the time the PWM parameters are reloaded. This ensures that new prescaler values for the PWM signals, as well as the synchronization signal, are applied at the same time. Write the synchronization signal *prescaler* parameter address to the *sync_presc_addr* parameter to enable this mechanism. Write 0 to disable it, and remember to set the synchronization signal *presc_copy* parameter instead of the *prescaler* parameter in this case.

Host Interface











 Written By CPU	 Written by both CPU and TPU
 Written By TPU	 Not Used

Table 8. svmStd3_sync Control Bits

Name	Options
<div style="display: flex; justify-content: space-around; width: 100px;"> 3210 </div>  Channel Function Select	svmStd3_sync function number (Assigned during assembly the DPTRAM code from library TPU functions)
<div style="display: flex; justify-content: space-around; width: 100px;"> 10 </div>  Channel Priority	00 – Channel Disabled 01 – Low Priority 10 – Middle Priority 11 – High Priority
<div style="display: flex; justify-content: space-around; width: 100px;"> 10 </div>  Host Service Bits (HSR)	00 – No Host Service Request 01 – Not used 10 – Initialization 11 – Not used
<div style="display: flex; justify-content: space-around; width: 100px;"> 10 </div>  Host Sequence Bits (HSQ)	xx – Not used
<div style="display: flex; justify-content: space-around; width: 100px;"> 0 </div>  Channel Interrupt Enable	0 – Channel Interrupt Disabled 1 – Channel Interrupt Enabled
<div style="display: flex; justify-content: space-around; width: 100px;"> 0 </div>  Channel Interrupt Status	0 – Interrupt Not Asserted 1 – Interrupt Asserted

TPU function svmStd3_sync generates an interrupt after each low to high transition.

Table 9. svmStd3_sync Parameter RAM

Channel	Parameter	15	14	13	12	11	10	9	8	7	6	5	4	3	2	1	0	
Synchronization channel	0	move																
	1	pw																
	2	prescaler																
	3	presc_copy																
	4	time																
	5	dec																
	6	T_copy																
	7																	

Table 10. svmStd3_sync parameter description

Parameter	Format	Description
Parameters written by CPU		
move	16-bit signed integer	The number of TCR1 TPU cycles to forego (negative) or come after (positive) the PWM period center time
pw	16-bit unsigned integer	Synchronization pulse width in number of TCR1 TPU cycles.
prescaler	16-bit unsigned integer	The number of PWM periods per synchronization pulse – use in case of synchronized prescalers change
presc_copy	16-bit unsigned integer	The number of PWM periods per synchronization pulse – use in case of asynchronous prescalers change
Parameters written by TPU		
Other parameters are just for TPU function inner use.		

Performance

There is one limitation. The absolute value of parameter *move* has to be less than a quarter of the PWM period *T*.

$$|move| < \frac{T}{4}$$

Table 11. svmStd3_sync State Statistics

State	Max IMB Clock Cycles	RAM Accesses by TPU
INIT	12	5

Table 11. svmStd3_sync State Statistics

State	Max IMB Clock Cycles	RAM Accesses by TPU
S1	12	6
S2	8	3
S3	16	7

NOTE: Execution times do not include the time slot transition time ($TST = 10$ or 14 IMB clocks)

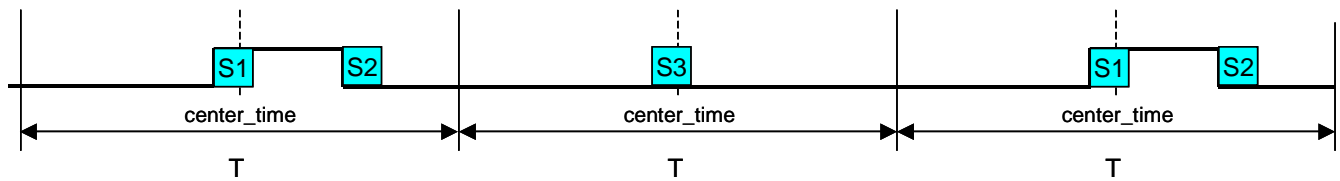

Figure 9. svmStd3_sync timing

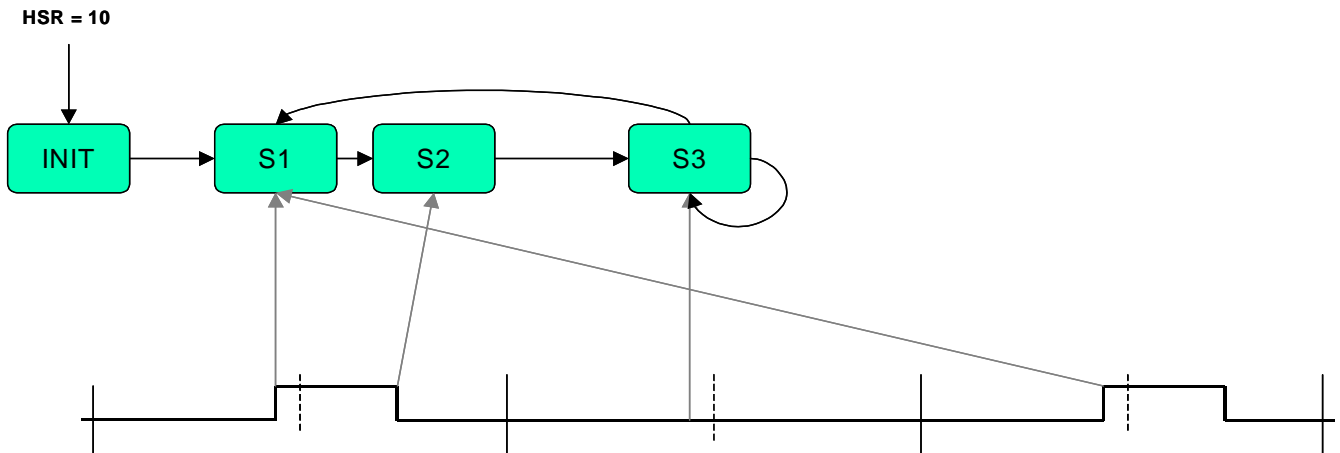

Figure 10. svmStd3_sync state diagram

Resolver Reference Signal for Standard Space Vector Modulation – 3 outputs version (svmStd3_res)

The svmStd3_res TPU function uses information read from the svmStd3 PWM functions, the actual PWM center times and the PWM periods. This allows a signal to be generated, which tracks the changes of the PWM period and is always synchronized with the PWM. The resolver reference signal is a 50% duty-cycle signal with a period equal to *prescaler* or synchronization channel *presc_copy* PWM periods (see next paragraph). The low to high transition of the pulse can be adjusted by a parameter, either negative or positive, to go a number of TCR1 TPU cycles before or after the PWM period center time.

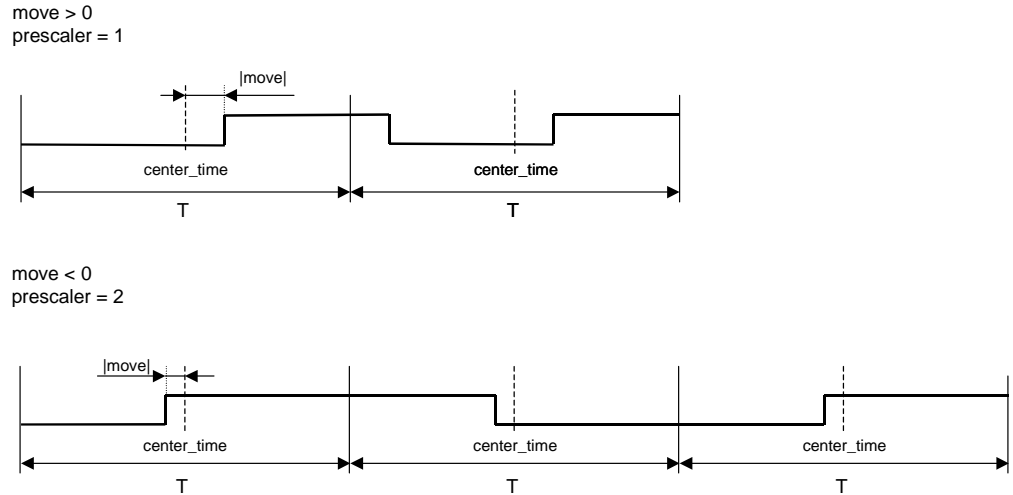

Figure 11. Resolver reference signal adjustment examples

Synchronized Change of PWM Prescaler And Resolver Reference Signals Prescaler

The svmStd3_res TPU function can inherit the Synchronization Signal prescaler that is synchronously changed with the PWM prescaler. Write the synchronization signals *presc_copy* parameter address to the *presc_addr* parameter to enable this mechanism. Write 0 to disable it, and in this case set the *prescaler* parameter to directly specify prescaler value.

Host Interface

- Written By CPU
- Written by both CPU and TPU
- Written By TPU
- Not Used

Table 12. svmStd3_res Control Bits

Name	Options
<div style="display: flex; justify-content: space-around; width: 100px;"> 3210 </div> <div style="display: flex; align-items: center;"> <div style="border: 1px solid black; width: 15px; height: 15px; margin-right: 5px;"></div> <div style="border: 1px solid black; width: 15px; height: 15px; margin-right: 5px;"></div> <div style="border: 1px solid black; width: 15px; height: 15px; margin-right: 5px;"></div> <div style="border: 1px solid black; width: 15px; height: 15px;"></div> Channel Function Select </div>	svmStd3_res function number (Assigned during assembly the DPTRAM code from library TPU functions)
<div style="display: flex; justify-content: space-around; width: 100px;"> 10 </div> <div style="display: flex; align-items: center;"> <div style="border: 1px solid black; width: 15px; height: 15px; margin-right: 5px;"></div> <div style="border: 1px solid black; width: 15px; height: 15px;"></div> Channel Priority </div>	00 – Channel Disabled 01 – Low Priority 10 – Middle Priority 11 – High Priority
<div style="display: flex; justify-content: space-around; width: 100px;"> 10 </div> <div style="display: flex; align-items: center;"> <div style="border: 1px solid black; width: 15px; height: 15px; margin-right: 5px;"></div> <div style="border: 1px solid black; width: 15px; height: 15px;"></div> Host Service Bits (HSR) </div>	00 – No Host Service Request 01 – Not used 10 – Initialization 11 – Not used

Table 12. svmStd3_res Control Bits

Name	Options
<div style="display: flex; align-items: center;"> <div style="margin-right: 10px;"> <div style="display: flex; justify-content: space-around; width: 20px;"> 10 </div> <div style="display: flex; justify-content: space-around; width: 20px;"> <div style="width: 10px; height: 10px; background-color: red;"></div> <div style="width: 10px; height: 10px; background-color: red;"></div> </div> </div> <div> Host Sequence Bits (HSQ) </div> <div style="margin-left: 20px;"> xx – Not used </div> </div>	
<div style="display: flex; align-items: center;"> <div style="margin-right: 10px;"> <div style="width: 20px; height: 10px; background-color: red;"></div> </div> <div> Channel Interrupt Enable </div> <div style="margin-left: 20px;"> x – Not used </div> </div>	
<div style="display: flex; align-items: center;"> <div style="margin-right: 10px;"> <div style="width: 20px; height: 10px; background-color: red;"></div> </div> <div> Channel Interrupt Status </div> <div style="margin-left: 20px;"> x – Not used </div> </div>	

Table 13. svmStd3_res Parameter RAM

Channel	Parameter	15	14	13	12	11	10	9	8	7	6	5	4	3	2	1	0
Resolver	0	move															
	1																
	2	presc_addr															
	3	prescaler															
	4																
	5																
	6																
	7																

Table 14. svmStd3_res parameter description

Parameter	Format	Description
Parameters written by CPU		
move	16-bit signed integer	The number of TCR1 TPU cycles to forego (negative) or come after (positive) the PWM period center time
presc_addr	16-bit unsigned integer	\$00X6, where X is a number of Synchronization Signal channel, to inherit Sync. channel prescaler or \$0000 to enable direct specification of prescaler value in prescaler parameter
prescaler	1, 2, 4, 6, 8, 10, 12, 14, ...	The number of PWM periods per synchronization pulse – use when apresc_addr = 0
Parameters written by TPU		

Table 14. svmStd3_res parameter description

Parameter	Format	Description
Other parameters are just for TPU function inner use.		

Performance

There is one limitation. The absolute value of parameter *move* has to be less than a quarter of the PWM period *T*.

$$|move| < \frac{T}{4}$$

Table 15. svmStd3_res State Statistics

State	Max IMB Clock Cycles	RAM Accesses by TPU
INIT	12	5
S1	26	9
S3	18	7

NOTE: Execution times do not include the time slot transition time ($TST = 10$ or 14 IMB clocks)

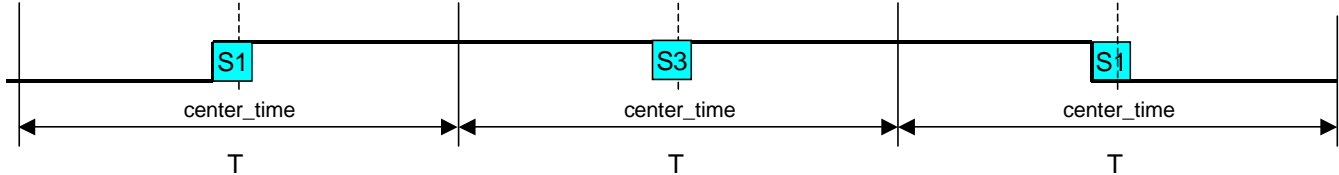

Figure 12. svmStd3_res timing

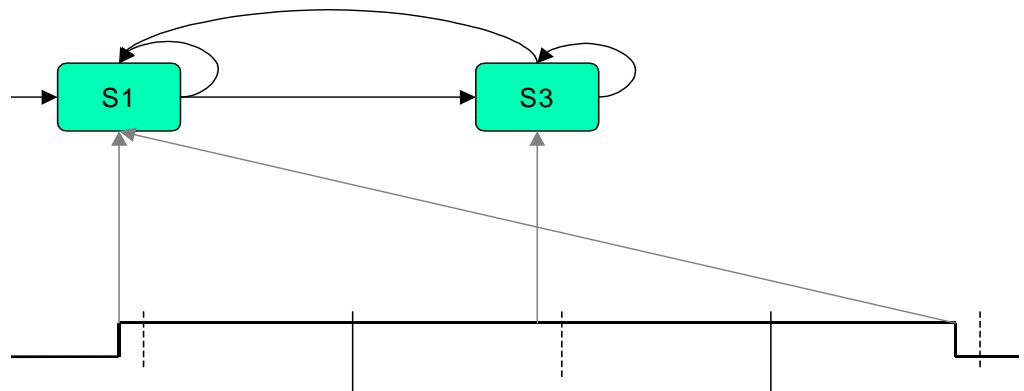

Figure 13. svmStd3_res state diagram

Fault Input for Standard Space Vector Modulation – 3 outputs version (svmStd3_fault)

The svmStd3_fault is an input TPU function that monitors the pin, and if a high to low transition occurs, immediately sets all PWM channels low and cancels all further transitions on them. The PWM channels, as well as the synchronization and resolver reference signal channels (if used), have to be initialized again to start them running.

The function returns the actual pinstate as a value of 0 (low) or 1 (high) in the parameter *fault_pinstate*. The parameter is placed on the Phase A channel to keep the fault channel parameter space free.

Host Interface

- Written By CPU
- Written by both CPU and TPU
- Written By TPU
- Not Used

Table 16. svmStd3_fault Control Bits

Name	Options
<div style="display: flex; justify-content: space-around; font-size: small;"> 3210 </div> <div style="display: flex; align-items: center; margin-top: 5px;"> <div style="display: flex; gap: 5px;"> <div style="width: 15px; height: 15px; border: 1px solid black; background-color: white;"></div> <div style="width: 15px; height: 15px; border: 1px solid black; background-color: white;"></div> <div style="width: 15px; height: 15px; border: 1px solid black; background-color: white;"></div> <div style="width: 15px; height: 15px; border: 1px solid black; background-color: white;"></div> </div> Channel Function Select </div>	svmStd3_fault function number (Assigned during assembly the DPTRAM code from library TPU functions)
<div style="display: flex; justify-content: center; font-size: small; margin-bottom: 5px;"> 10 </div> <div style="display: flex; align-items: center; margin-top: 5px;"> <div style="display: flex; gap: 5px;"> <div style="width: 15px; height: 15px; border: 1px solid black; background-color: white;"></div> <div style="width: 15px; height: 15px; border: 1px solid black; background-color: white;"></div> </div> Channel Priority </div>	00 – Channel Disabled 01 – Low Priority 10 – Middle Priority 11 – High Priority

Table 16. svmStd3_fault Control Bits

Name	Options
<div style="display: flex; align-items: center;"> <div style="margin-right: 10px;"> <div style="display: flex; justify-content: space-between; width: 20px;"> 10 </div> <div style="border: 1px solid black; width: 15px; height: 15px; margin: 2px;"></div> <div style="border: 1px solid black; width: 15px; height: 15px; margin: 2px;"></div> </div> <div>Host Service Bits (HSR)</div> </div>	00 – No Host Service Request 01 – Not used 10 – Initialization 11 – Not used
<div style="display: flex; align-items: center;"> <div style="margin-right: 10px;"> <div style="display: flex; justify-content: space-between; width: 20px;"> 10 </div> <div style="background-color: green; border: 1px solid black; width: 15px; height: 15px; margin: 2px;"></div> <div style="background-color: green; border: 1px solid black; width: 15px; height: 15px; margin: 2px;"></div> </div> <div>Host Sequence Bits (HSQ)</div> </div>	xx – Not used
<div style="display: flex; align-items: center;"> <div style="margin-right: 10px;"> <div style="display: flex; justify-content: space-between; width: 20px;"> 0 </div> <div style="border: 1px solid black; width: 15px; height: 15px; margin: 2px;"></div> </div> <div>Channel Interrupt Enable</div> </div>	0 – Channel Interrupt Disabled 1 – Channel Interrupt Enabled
<div style="display: flex; align-items: center;"> <div style="margin-right: 10px;"> <div style="display: flex; justify-content: space-between; width: 20px;"> 0 </div> <div style="background-color: blue; border: 1px solid black; width: 15px; height: 15px; margin: 2px;"></div> </div> <div>Channel Interrupt Status</div> </div>	0 – Interrupt Not Asserted 1 – Interrupt Asserted

TPU function svmStd3_fault generates an interrupt when a high to low transition appears.

Table 17. svmStd3_fault Parameter RAM

Channel	Parameter	15	14	13	12	11	10	9	8	7	6	5	4	3	2	1	0
Fault input	0																
	1																
	2																
	3																
	4																
	5																
	6																
	7																

Table 18. svmStd3_fault parameter description

Parameter	Format	Description
Parameters written by TPU		
fault_pinstate	0 or 1	State of fault pin: 0 ... low 1 ... high

Performance

Table 19. svmStd3_fault State Statistics

State	Max IMB Clock Cycles	RAM Accesses by TPU
INIT	8	2
FAULT	26	1

Table 19. svmStd3_fault State Statistics

State	Max IMB Clock Cycles	RAM Accesses by TPU
NO_FAULT	4	1

NOTE: Execution times do not include the time slot transition time (TST = 10 or 14 IMB clocks)



Figure 14. svmStd3_fault timing

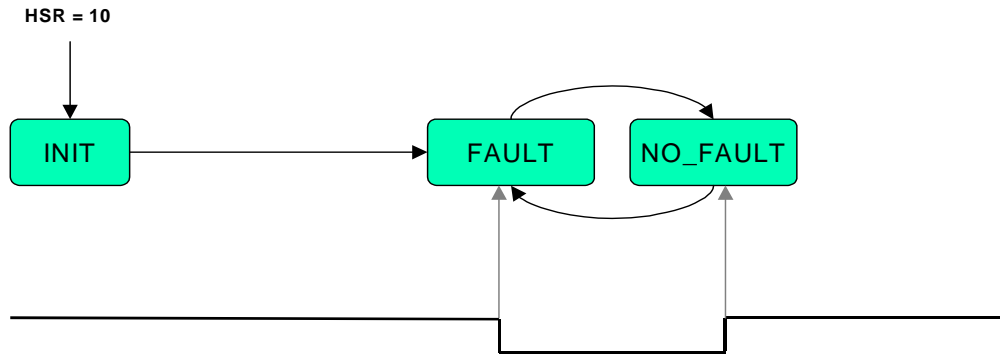

Figure 15. svmStd3_fault state diagram

HOW TO REACH US:

USA/EUROPE/LOCATIONS NOT LISTED:

Motorola Literature Distribution
P.O. Box 5405
Denver, Colorado 80217
1-800-521-6274 or 480-768-2130

JAPAN:

Motorola Japan Ltd.
SPS, Technical Information Center
3-20-1, Minami-Azabu, Minato-ku
Tokyo 106-8573, Japan
81-3-3440-3569

ASIA/PACIFIC:

Motorola Semiconductors H.K. Ltd.
Silicon Harbour Centre
2 Dai King Street
Tai Po Industrial Estate
Tai Po, N.T., Hong Kong
852-26668334

HOME PAGE:

<http://motorola.com/semiconductors>



Information in this document is provided solely to enable system and software implementers to use Motorola products. There are no express or implied copyright licenses granted hereunder to design or fabricate any integrated circuits or integrated circuits based on the information in this document.

Motorola reserves the right to make changes without further notice to any products herein. Motorola makes no warranty, representation or guarantee regarding the suitability of its products for any particular purpose, nor does Motorola assume any liability arising out of the application or use of any product or circuit, and specifically disclaims any and all liability, including without limitation consequential or incidental damages. "Typical" parameters that may be provided in Motorola data sheets and/or specifications can and do vary in different applications and actual performance may vary over time. All operating parameters, including "Typicals", must be validated for each customer application by customer's technical experts. Motorola does not convey any license under its patent rights nor the rights of others. Motorola products are not designed, intended, or authorized for use as components in systems intended for surgical implant into the body, or other applications intended to support or sustain life, or for any other application in which the failure of the Motorola product could create a situation where personal injury or death may occur. Should Buyer purchase or use Motorola products for any such unintended or unauthorized application, Buyer shall indemnify and hold Motorola and its officers, employees, subsidiaries, affiliates, and distributors harmless against all claims, costs, damages, and expenses, and reasonable attorney fees arising out of, directly or indirectly, any claim of personal injury or death associated with such unintended or unauthorized use, even if such claim alleges that Motorola was negligent regarding the design or manufacture of the part.

MOTOROLA and the Stylized M Logo are registered in the US Patent and Trademark Office. All other product or service names are the property of their respective owners. Motorola, Inc. is an Equal Opportunity/Affirmative Action Employer.

© Motorola Inc. 2003

AN2532/D
Rev. 0
5/2003

**For More Information On This Product,
Go to: www.freescale.com**

This datasheet has been downloaded from:

www.DatasheetCatalog.com

Datasheets for electronic components.



LittleDiode supplies new, hard to find or obsolete electronic components and semiconductors all over the world.

With over two million different components listed you are sure to find the part you need.

Feel free to visit us today at our online store:

LittleDiode.com

Looking forward to providing you with the best possible service.