

# AN2104NFHQ

## Digital Pre-Processing IC

### ■ Overview

The AN2104NFHQ is a digital pre-processing IC for CCD cameras. It is a single chip IC including a 10-bit A/D converter as well as CDS and AGC circuits. The CDS circuit achieves high-speed sampling at rates up to 25 MHz, and thus the AN2104NFHQ can support advanced CCD cameras developing in higher density pixels and image quality, such as XGA or SXGA resolutions. The AGC and OB circuits can be adjusted with 9-bit and 8-bit serial data respectively through on-chip D/A converter.

### ■ Features

- Low power (114 mW typ. at 3 V supply voltage)
- High-speed sample-and-hold circuit operates up to 25 MHz.
- The AGC can be adjusted over 0.5 dB to 36 dB range.
- The OB circuit is adjustable over a  $\{V_{RB} \text{ to } V_{RB} + (V_{RT} - V_{RB}) / 4\}$  range.
- On-chip A/D converter reference voltage supply circuit ( $V_{RT}$  and  $V_{RB}$ )
- On-chip 10-bit A/D converter (maximum conversion speed: 25 MSPS)
- Built-in 3-channel 8-bit D/A converter for adjustments and mode settings.

### ■ Applications

- Digital still cameras
- Video cameras
- PC input cameras
- Surveillance cameras
- Board cameras
- Cameras that use CCDs and digital signal processing.

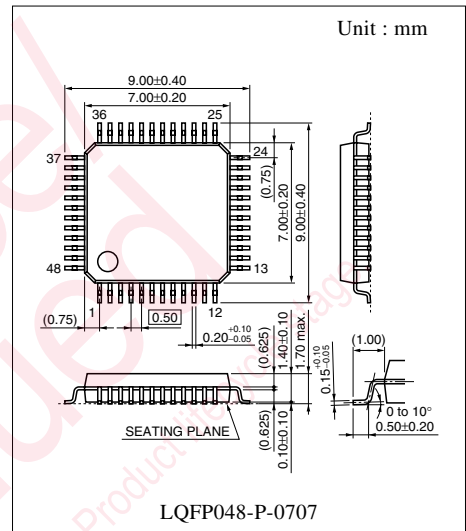

Note) The package of this product will be changed to lead-free type (LQFP048-P-0707A). See the new package dimensions section later of this datasheet.

■ Block Diagram

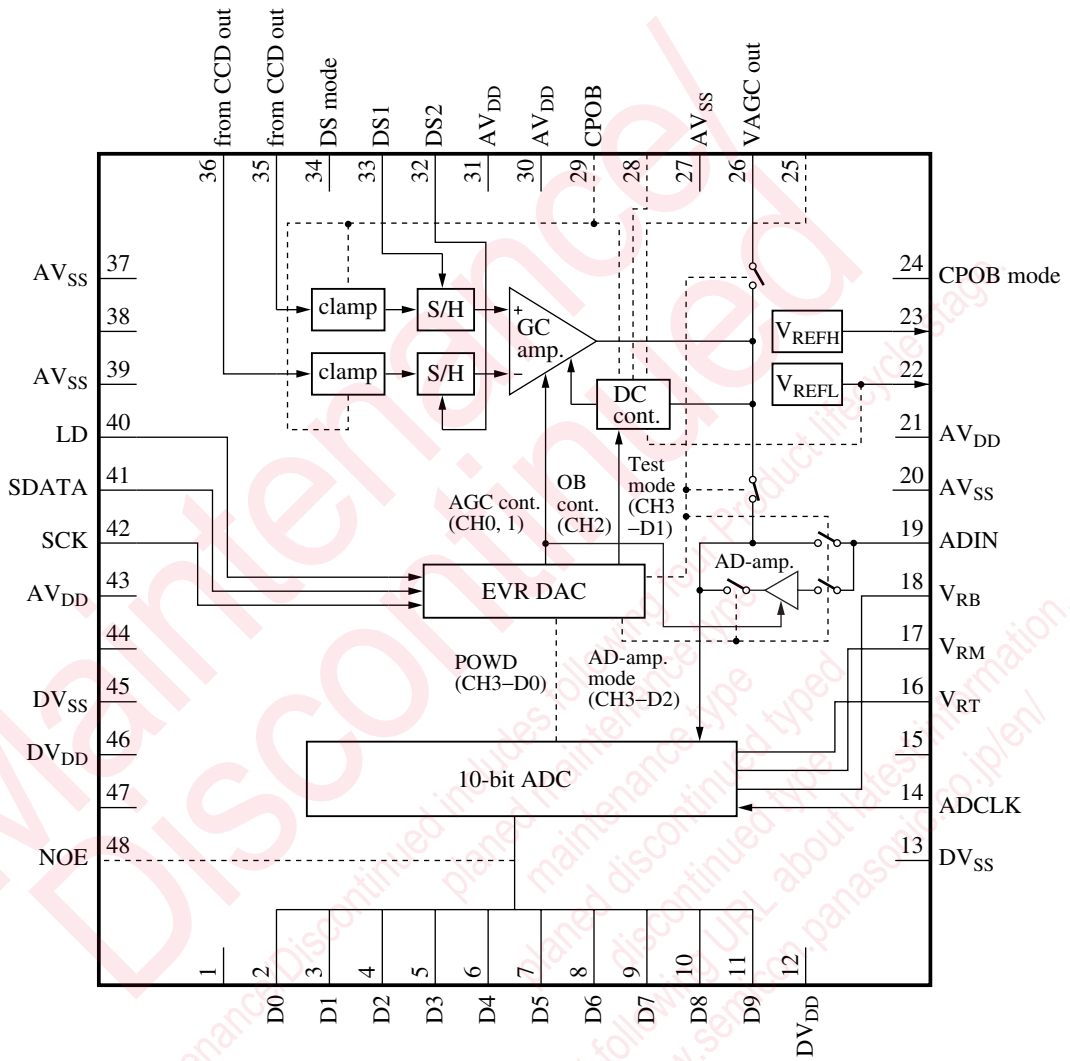

## ■ Pin Descriptions

Pin No.	Description	Pin No.	Description
1	Unused (Must be connected to ground.)	25	Output OB level stabilization
2	A/D converter output D0	26	AGC output in test mode
3	A/D converter output D1	27	Analog system ground 2
4	A/D converter output D2	28	Input DC level stabilization
5	A/D converter output D3	29	CPOB pulse input
6	A/D converter output D4	30	Analog system power supply 2
7	A/D converter output D5	31	Analog system power supply 3
8	A/D converter output D6	32	DS2 pulse input
9	A/D converter output D7	33	DS1 pulse input
10	A/D converter output D8	34	DS1 and DS2 pulse. Active high/active low setting
11	A/D converter output D9	35	CCD output signal input 1
12	Digital system power supply 1	36	CCD output signal input 2
13	Digital system ground 1	37	Analog system ground 3
14	A/D converter clock input	38	Unused (Must be connected to ground.)
15	Unused (Must be connected to ground.)	39	Analog system ground 4
16	A/D converter reference supply $V_{RT}$ input	40	Load pulse input
17	A/D converter reference supply $V_{RM}$	41	Serial data input
18	A/D converter reference supply $V_{RB}$ input	42	Serial clock input
19	AGC input in test mode	43	Analog system power supply 4
20	Analog system ground 1	44	Unused (Must be connected to ground.)
21	Analog system power supply 1	45	Digital system ground 2
22	Reference voltage supply $V_{REFL}$ output (1.1 V typical)	46	Digital system power supply 2
23	Reference voltage supply $V_{REFH}$ output (2.5 V typical)	47	Unused (Must be connected to ground.)
24	CPOB pulse. Active high/active low setting	48	A/D converter output enable setting

## ■ Absolute Maximum Ratings

Parameter	Symbol	Rating	Unit
Supply voltage	$V_{DD}$	-0.3 to +4.6	V
Supply current	$I_{DD}$	—	mA
Power dissipation *2	$P_D$	226	mW
Operating temperature *1	$T_{opr}$	-20 to +75	°C
Storage temperature *1	$T_{stg}$	-55 to +125	°C

Notes: \*1 : Except for the operating temperature and storage temperature, all items are measured at  $T_a = 25$  °C.

\*2 : The power dissipation is for the package at  $T_a = 75$  °C in free air.

### ■ Recommended Operating Range

Parameter	Symbol	Range	Unit
Supply voltage	$V_{CC}$	2.7 to 3.0 to 3.6	V

### ■ Electrical Characteristics at $AV_{DD} = DV_{DD} = 3.0\text{ V}$ , $T_a = 25\text{ °C}$

Parameter	Symbol	Conditions	Min	Typ	Max	Unit
Supply current (in CDS mode)	$I_{DD1}$	$AV_{DD} = DV_{DD} = 3.0\text{ V}$ , $f_{CLK} = 25\text{ MHz}$	—	38	51	mA
Supply current (in AD amplifier mode)	$I_{DD2}$	$AV_{DD} = DV_{DD} = 3.0\text{ V}$ , $f_{CLK} = 25\text{ MHz}$	—	24	39	mA
Low power mode supply current	$I_{POWD}$	$f_{CLK} = 25\text{ MHz}$	—	5.0	16	mA
Reference voltage (1)	$V_{REFH}$	$AV_{DD} = DV_{DD} = 3.0\text{ V}$	2.3	2.5	2.7	V
Reference voltage (2)	$V_{REFL}$	$AV_{DD} = DV_{DD} = 3.0\text{ V}$	0.8	1.0	1.2	V
CPOB pulse input voltage high level	$CPOB_H$	—	2.4	—	$V_{DD}$	V
CPOB pulse input voltage low level	$CPOB_L$	—	$V_{SS}$	—	0.8	V
DS1 pulse input voltage high level	$DS1_H$	—	2.4	—	$V_{DD}$	V
DS1 pulse input voltage low level	$DS1_L$	—	$V_{SS}$	—	0.8	V
DS2 pulse input voltage high level	$DS2_H$	—	2.4	—	$V_{DD}$	V
DS2 pulse input voltage low level	$DS2_L$	—	$V_{SS}$	—	0.8	V
AGC frequency characteristics	$G_{fA}$	10 MHz, with upper blanking, sine wave, 300 mV[p-p]	-2.9	-0.4	2.1	dB
AGC input dynamic range	$G_{AG3}$	With upper BLK, sine wave, 600 mV[p-p]	-1.8	0	1.8	dB
Minimum AGC gain	$G_{AG4}$	With upper BLK, sine wave, 300 mV[p-p]	-2.0	0.5	3.0	dB
Maximum AGC gain	$G_{AG5}$	With upper BLK, sine wave, 20 mV[p-p]	32.0	36.0	40.0	dB
AGC output dynamic range	$V_{AG6}$	With upper BLK, sine wave, 50 mV[p-p]	1350	1700	—	mV[p-p]
AGC output DC (1)	$V_{OFF1}$	CH2 = 00, the difference with respect to $V_{REF}$	-70	0	70	mV
AGC output DC (2)	$V_{OFF2}$	CH2 = FF, the difference with respect to $(V_{REFH} - V_{REFL})/4$	-70	0	70	mV
CDS sampling capability	$G_{CDS}$	DS1 = DS2 = 25 MHz CDS input: 300 mV[p-p]	-2.0	0	2.0	dB
Reference resistor ( $V_{RB}$ to $V_{RT}$ )	$R_{REF}$	—	278	570	950	$\Omega$
AD-amplifier maximum gain	$G_{AA1}$	3.58 MHz sine wave, 300 mV[p-p]	5.0	—	—	dB
AD-amplifier minimum gain	$G_{AA2}$	3.58 MHz sine wave, 300 mV[p-p]	—	—	-2.0	dB

**■ Electrical Characteristics (continued) at  $V_{DD} = DV_{DD} = 3.0\text{ V}$ ,  $T_a = 25\text{ °C}$** 

Parameter	Symbol	Conditions	Min	Typ	Max	Unit
Digital input current (high)	$I_{DINH}$	CLK and POWD pins Pin19 = $0.8 \times V_{DD}$	—	—	45	$\mu\text{A}$
Digital input current (low)	$I_{DINL}$	CLK and POWD pins Pin19 = $0.2 \times V_{DD}$	—	—	45	$\mu\text{A}$
Analog input current (high)	$I_{AIH}$	Pin19 = 3.0 V	—	—	200	$\mu\text{A}$
Analog input current (low)	$I_{AIL}$	Pin19 = 0.5 V	-200	—	—	$\mu\text{A}$
High-level digital input current	$V_{IH}$	—	2.4	—	$V_{DD}$	V
Low-level digital input current	$V_{IL}$	—	$V_{SS}$	—	0.8	V
High-level digital output current	$I_{OH}$	$V_{OH} = 0.8 \times V_{DD}$	—	—	-1.5	mA
Low-level digital output current	$I_{OL}$	$V_{OL} = -0.2 \times V_{DD}$	1.5	—	—	mA
Differential linearity error	$E_D$	—	—	$\pm 0.5$	$\pm 1.0$	LSB
Dynamic linearity error	$DE_L$	$f_{CLK} = 25\text{ MHz}$ , $f_{IN} = 12.5\text{ MHz}$	—	—	$\pm 13$	LSB
Quantization noise *1	S/N	$f_{CLK} = 20\text{ MHz}$ , $f_{IN} = 3.58\text{ MHz}$	42	47	—	dB



Note: \*1. Including the total harmonic distortion.

**• Design Reference Data**

Note: The characteristics shown below are design reference values, and are not guaranteed.

Parameter	Symbol	Conditions	Min	Typ	Max	Unit
Maximum conversion rate	$F_{CMAX}$	—	25	—	—	MSPS
Reference voltage difference	$V_{DELTA}$	$AV_{DD} = DV_{DD} = 3.0\text{ V}$	1.38	1.48	1.58	V

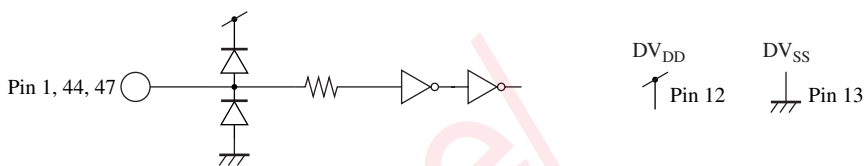
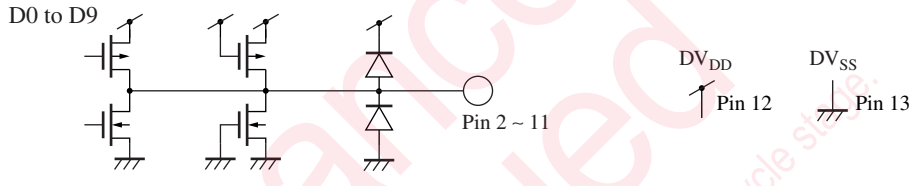
■ Terminal Equivalent Circuits

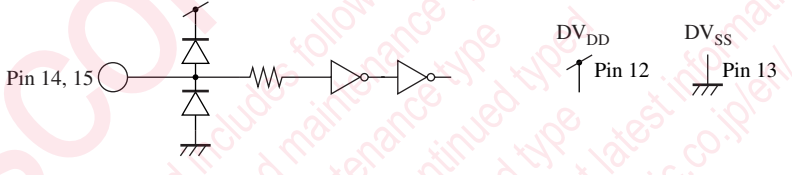
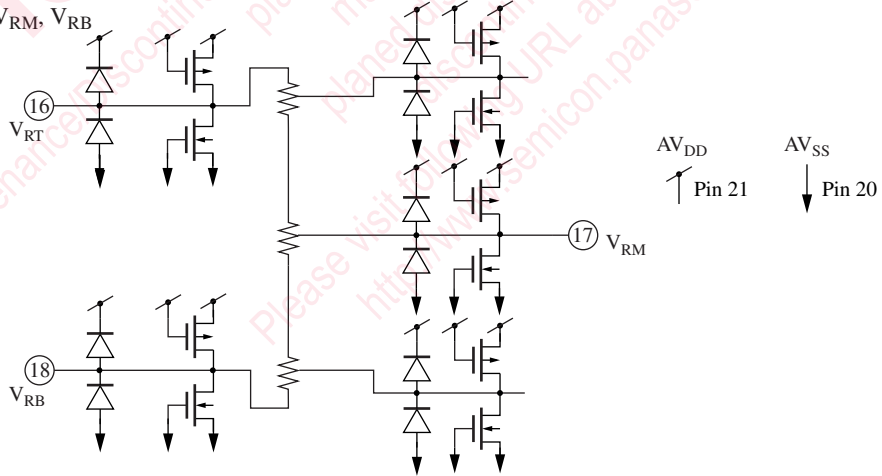
Pin No.	Equivalent circuit
1	<p>N.C. (Ground to analog system ground)</p> 
2 to 11	<p>D0 to D9</p> 
12 13	<p>Pin 12 : DV<sub>DD</sub></p> <p>Pin 13 : DV<sub>SS</sub></p> 
14 15	<p>Pin 14 : ADCLK</p> <p>Pin 15 : N.C. (Ground to analog system ground)</p> 
16 17 18	<p>V<sub>RT</sub>, V<sub>RM</sub>, V<sub>RB</sub></p> 

■ Terminal Equivalent Circuits (continued)

Pin No.	Equivalent circuit
19	<p>ADIN</p> <p>ADIN (19)</p> <p>AV<sub>DD</sub> ↑ Pin 21    AV<sub>SS</sub> ↓ Pin 20</p>
20 21	<p>Pin 20 : AV<sub>SS</sub> ↓</p> <p>Pin 21 : AV<sub>DD</sub> ↑</p>
22 23	<p>Pin 22 : V<sub>REFL</sub> Pin 23 : V<sub>REFH</sub></p> <p>Pin 22, 23</p> <p>AV<sub>DD</sub> ↑ Pin 30    AV<sub>SS</sub> ↓ Pin 27</p>
24	<p>CPOB mode</p> <p>(24)</p> <p>AV<sub>DD</sub> ↑ Pin 30    AV<sub>SS</sub> ↓ Pin 27</p>
25	<p>VOBDAT</p> <p>Pin 25, 28</p> <p>AV<sub>DD</sub> ↑ Pin 30    AV<sub>SS</sub> ↓ Pin 27</p>
26	<p>V<sub>AGC</sub> out</p> <p>(26)</p> <p>AV<sub>DD</sub> ↑ Pin 30    AV<sub>SS</sub> ↓ Pin 27</p>

■ Terminal Equivalent Circuits (continued)

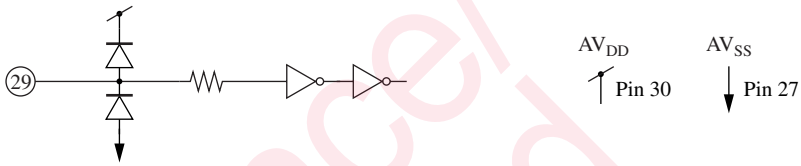
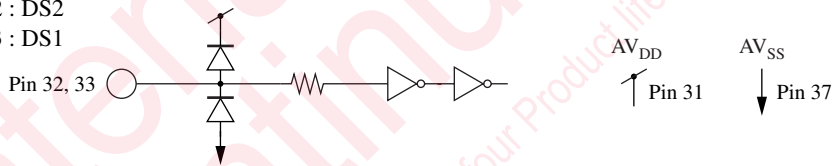
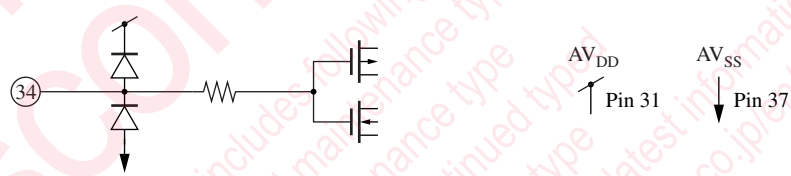
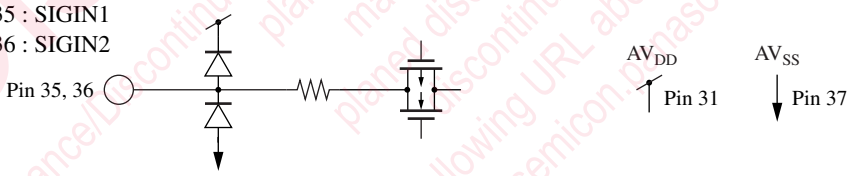
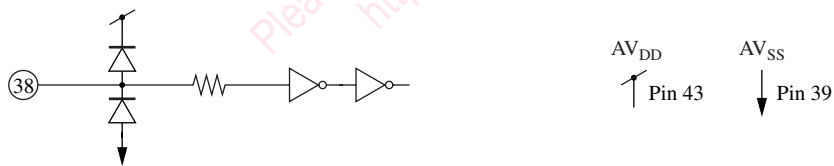
Pin No.	Equivalent circuit
27	Analog ground
28	VCLIPDAT See pin 25
29	CPOB 
30	AV <sub>DD</sub> (analog system power supply 2)
31	AV <sub>DD</sub> (analog system power supply 3)
32 33	Pin 32 : DS2 Pin 33 : DS1 
34	DS mode 
35 36	Pin 35 : SIGIN1 Pin 36 : SIGIN2 
37	Analog ground3
38	Unused (Must be connected to ground.) 
39	Analog ground 4

■ Terminal Equivalent Circuits (continued)

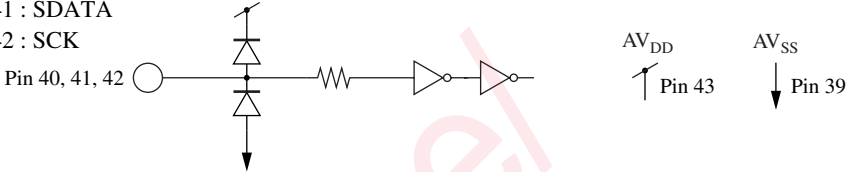
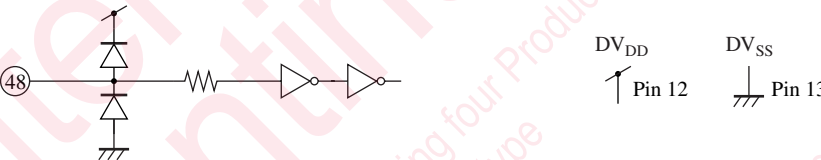
Pin No.	Equivalent circuit
40 41 42	<p data-bbox="289 253 452 334">Pin 40 : LD Pin 41 : SDATA Pin 42 : SCK</p> <p data-bbox="340 349 500 374">Pin 40, 41, 42</p> 
43	Analog system power supply 4
44	Unused (Must be connected to ground.)
45	Digital system ground 2
46	Digital system power supply 2
47	Unused (Must be connected to ground.)
48	<p data-bbox="289 736 340 761">NOE</p> <p data-bbox="367 817 395 842">(48)</p> 

■ Application Circuit Example

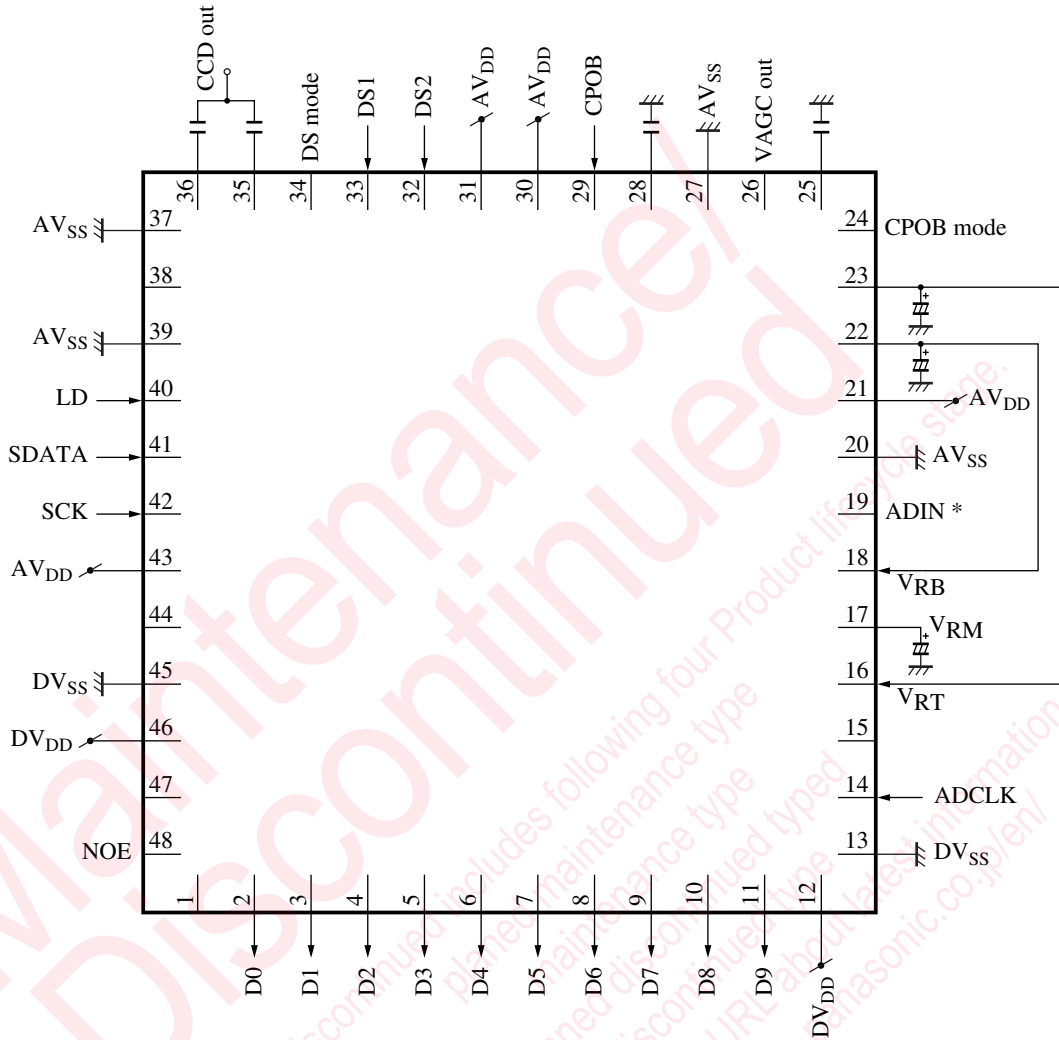

Note \*: When the AD amplifier is used, signals should be input to pin 19 through a capacitor. (Assumed chrominance signal may be input.)

■ Usage Notes

The unused pins (pins 1, 15, 38, 44, and 47) are connected internally to the circuit shown in the "Pin Equivalent Circuits" table. Therefore, these pins must be held fixed at either  $V_{SS}$  or  $V_{DD}$ .

■ New Package Dimensions (Unit: mm)

- LQFP048-P-0707A (Lead-free package)

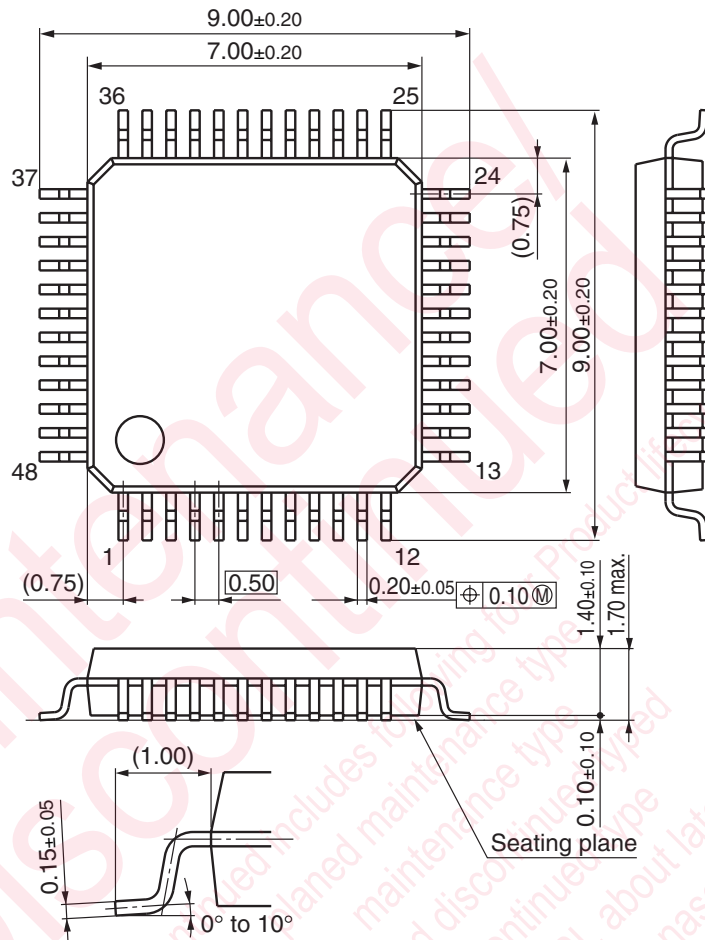

## Request for your special attention and precautions in using the technical information and semiconductors described in this book

- (1) If any of the products or technical information described in this book is to be exported or provided to non-residents, the laws and regulations of the exporting country, especially, those with regard to security export control, must be observed.
- (2) The technical information described in this book is intended only to show the main characteristics and application circuit examples of the products, and no license is granted under any intellectual property right or other right owned by our company or any other company. Therefore, no responsibility is assumed by our company as to the infringement upon any such right owned by any other company which may arise as a result of the use of technical information described in this book.
- (3) The products described in this book are intended to be used for standard applications or general electronic equipment (such as office equipment, communications equipment, measuring instruments and household appliances).  
Consult our sales staff in advance for information on the following applications:
  - Special applications (such as for airplanes, aerospace, automobiles, traffic control equipment, combustion equipment, life support systems and safety devices) in which exceptional quality and reliability are required, or if the failure or malfunction of the products may directly jeopardize life or harm the human body.
  - Any applications other than the standard applications intended.
- (4) The products and product specifications described in this book are subject to change without notice for modification and/or improvement. At the final stage of your design, purchasing, or use of the products, therefore, ask for the most up-to-date Product Standards in advance to make sure that the latest specifications satisfy your requirements.
- (5) When designing your equipment, comply with the range of absolute maximum rating and the guaranteed operating conditions (operating power supply voltage and operating environment etc.). Especially, please be careful not to exceed the range of absolute maximum rating on the transient state, such as power-on, power-off and mode-switching. Otherwise, we will not be liable for any defect which may arise later in your equipment.
  - Even when the products are used within the guaranteed values, take into the consideration of incidence of break down and failure mode, possible to occur to semiconductor products. Measures on the systems such as redundant design, arresting the spread of fire or preventing glitch are recommended in order to prevent physical injury, fire, social damages, for example, by using the products.
- (6) Comply with the instructions for use in order to prevent breakdown and characteristics change due to external factors (ESD, EOS, thermal stress and mechanical stress) at the time of handling, mounting or at customer's process. When using products for which damp-proof packing is required, satisfy the conditions, such as shelf life and the elapsed time since first opening the packages.
- (7) This book may be not reprinted or reproduced whether wholly or partially, without the prior written permission of Matsushita Electric Industrial Co., Ltd.



LittleDiode supplies new, hard to find or obsolete electronic components and semiconductors all over the world.

With over two million different components listed you are sure to find the part you need.

Feel free to visit us today at our online store:

[LittleDiode.com](http://LittleDiode.com)

Looking forward to providing you with the best possible service.