

AN2042SB

Filter IC for CCD Video Camera Signal Processing

Overview

The AN2042SB is a filter IC to be used in a latter stage of CCD video camera signal processing. It filters and outputs the luminance and chroma signals sent from a DSP.

Features

- Built-in LPF for brightness signal
- Built-in BPF for chroma signal
- Built-in synchronous signal mixer

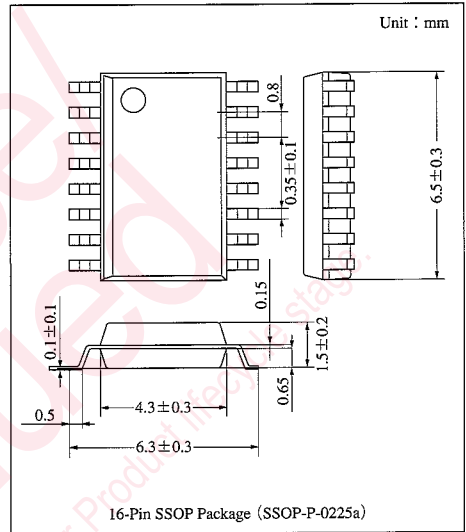

Block Diagram

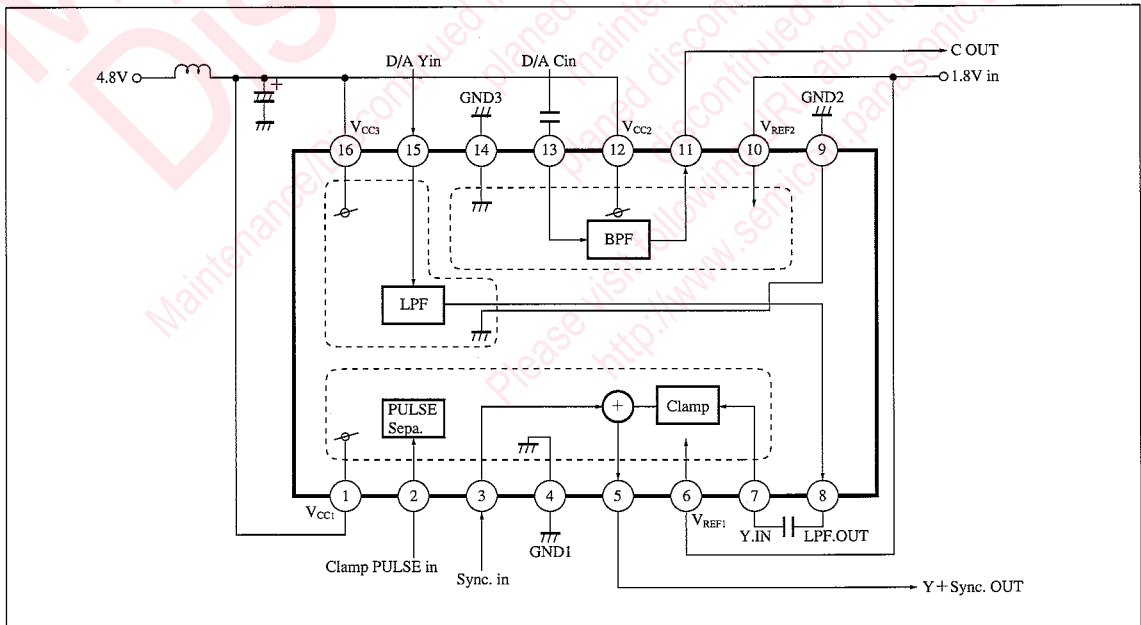

Pin Descriptions

Pin No.	Pin name	Pin No.	Pin name
1	V _{CC1}	9	GND2
2	Clamp pulse input	10	Reference voltage input 2
3	SYNC pulse input	11	Chroma signal output
4	GND1	12	V _{CC2}
5	Luminance + sync. signal output	13	D/A converter chroma signal input
6	Reference voltage input 1	14	GND3
7	Luminance signal input	15	D/A converter luminance signal input
8	Luminance LPF output	16	V _{CC3}

Absolute Maximum Ratings (T_a = 25°C)

Parameter	Symbol	Rating	Unit
Supply voltage	V _{CC}	5.5	V
Supply current	I _{CC}	15	mA
Power dissipation	P _D	83	mW
Operating ambient temperature ^{note)}	T _{opr}	-20 to +75	°C
Storage temperature ^{note)}	T _{stg}	-55 to +125	°C

Note) T_a = 25°C except operating temperature ambient and storage temperature.

Recommended Operating Range (T_a = 25°C)

Parameter	Symbol	Range
Operating supply voltage range	V _{CC}	4.5V to 5.1V

Electrical Characteristics (V_{CC} = 4.8V, T_a = 25 ± 2°C)

Parameter	Symbol	Condition	min	typ	max	Unit
Supply current	I _{CC}	V _{CC1} = V _{CC2} = V _{CC3} = 4.8V	7.0	10.0	13.0	mA
Clamp pulse separation level	THCP2	V _{CC1} = V _{CC2} = V _{CC3} = 4.8V	1.1	1.5	1.9	V
SYNC pulse separation level	THSYNC	V _{CC1} = V _{CC2} = V _{CC3} = 4.8V	1.1	1.5	1.9	V
Y filter input-output gain	GYLPF	input = Sine 100kHz, 700mV _{P-P}	-1.3	0	1.3	dB
Y filter amplitude characteristics	FYLPF	input = Sine 6MHz, 700mV _{P-P}	-7.0	-4.5	-2.0	dB
Y group-delay characteristics	DYLPF	input = Sine 1MHz, 700mV _{P-P}	95	130	165	ns
C filter input-output gain	GCBPF	input = Sine 3.58MHz, 500mV _{P-P}	-2.3	-1.0	0.3	dB
C filter amplitude characteristics (1)	FCBPF1	input = Sine 1MHz, 500mV _{P-P}	-14	-8	-4	dB
C filter amplitude characteristics (2)	FCBPF2	input = Sine 10MHz, 500mV _{P-P}	-14	-8	-4	dB
Y amp. gain	GYAMP	input = Sine 100kHz, 700mV _{P-P}	-1.2	0	1.2	dB
Y amp. dynamic range	DYAMP	input = 10STEP, 1500mV _{P-P}	1200	—	—	mV
SYNC level	SYNC	Pin⑦ = C - GND Pin③ = SYNC Pulse	260	286	312	mV

ICs for
Video
Camera

Pin Descriptions

Pin No.	Symbol	Waveform	Equivalent circuit	Description
1	V _{CC1}			Power supply
2	CP2 IN	<p>Input waveform</p>		Clamp pulse (CP2) input. 1.5V threshold. Grounded when not used.
3	SYNC IN	<p>Output waveform</p>		SYNC pulse input. Connect high (to V _{CC}) when not used. 1.5V threshold. Sync. signal (approx. 266 mV _{PP}) is mixed to NTSC-signal at Pin⑤.
4	GND1			Ground
5	Y+SYNC OUT	<p>Output waveform</p>		Y+SYNC signal output. 2.3V typ. DC output. 50-Ω output impedance. A luminance signal (Y signal) input at Pin⑦ is mixed with a sync. signal and those mixed signals are output.
6	V _{REF1}			Reference voltage input (1.8V typ.)

■ Pin Descriptions (cont.)

Pin No.	Symbol	Waveform	Equivalent circuit	Description
7	Y IN	<p>Input waveform</p>		<p>Clamp input for Y-signal passed LPF. This pin is coupled to Pin ⑧ through an external capacitor. The input signal is mixed with a sync. signal, and those mixed signals, are output at Pin⑤.</p>
8	YLP OUT	<p>Output waveform</p>		<p>Y signal output having passed through the LPF. 65-Ω output impedance. The DC output is Pin⑮ voltage $-V_D$ D/A converter-output Y signal that was input at Pin⑮ passes through the LPF and then output at this pin.</p>
9	GND2	—	—	Ground
10	VREF2	—	—	Reference voltage input (1.8V typ.)
11	C OUT	<p>Output waveform</p>		<p>Chroma signal output having passed through the BPF. 2.0V DC output. 65-Ω output impedance. D/A converter-output chroma signal that was input at Pin⑬ passes through the BPF and then output at this pin.</p>
12	VCC2	—	—	Power supply

ICs for Video Camera

■ Pin Descriptions (cont.)

Pin No.	Symbol	Waveform	Equivalent circuit	Description
13	D/A C IN	<p>Output waveform</p>		<p>D/A converter-output chroma signal input which is input through an external capacitor.</p> <p>DC input bias is V_{REF} plus V_D (2.5V typ.)</p> <p>The input at this pin passes through the internal BPF and then is output at Pin①.</p>
14	GND3			Ground
15	D/A Y IN	<p>Output waveform</p>		<p>D/A converter-output Y-signal input.</p> <p>1.8 to 4.3V input dynamic range.</p> <p>The input at this pin passes through the internal LPF and then is output at Pin⑧.</p>
16	V _{CC3}			Power supply

Request for your special attention and precautions in using the technical information and semiconductors described in this book

- (1) If any of the products or technical information described in this book is to be exported or provided to non-residents, the laws and regulations of the exporting country, especially, those with regard to security export control, must be observed.
- (2) The technical information described in this book is intended only to show the main characteristics and application circuit examples of the products. No license is granted in and to any intellectual property right or other right owned by Panasonic Corporation or any other company. Therefore, no responsibility is assumed by our company as to the infringement upon any such right owned by any other company which may arise as a result of the use of technical information described in this book.
- (3) The products described in this book are intended to be used for standard applications or general electronic equipment (such as office equipment, communications equipment, measuring instruments and household appliances).
Consult our sales staff in advance for information on the following applications:
 - Special applications (such as for airplanes, aerospace, automobiles, traffic control equipment, combustion equipment, life support systems and safety devices) in which exceptional quality and reliability are required, or if the failure or malfunction of the products may directly jeopardize life or harm the human body.
 - Any applications other than the standard applications intended.
- (4) The products and product specifications described in this book are subject to change without notice for modification and/or improvement. At the final stage of your design, purchasing, or use of the products, therefore, ask for the most up-to-date Product Standards in advance to make sure that the latest specifications satisfy your requirements.
- (5) When designing your equipment, comply with the range of absolute maximum rating and the guaranteed operating conditions (operating power supply voltage and operating environment etc.). Especially, please be careful not to exceed the range of absolute maximum rating on the transient state, such as power-on, power-off and mode-switching. Otherwise, we will not be liable for any defect which may arise later in your equipment.
 - Even when the products are used within the guaranteed values, take into the consideration of incidence of break down and failure mode, possible to occur to semiconductor products. Measures on the systems such as redundant design, arresting the spread of fire or preventing glitch are recommended in order to prevent physical injury, fire, social damages, for example, by using the products.
- (6) Comply with the instructions for use in order to prevent breakdown and characteristics change due to external factors (ESD, EOS, thermal stress and mechanical stress) at the time of handling, mounting or at customer's process. When using products for which damp-proof packing is required, satisfy the conditions, such as shelf life and the elapsed time since first opening the packages.
- (7) This book may be not reprinted or reproduced whether wholly or partially, without the prior written permission of our company.



LittleDiode supplies new, hard to find or obsolete electronic components and semiconductors all over the world.

With over two million different components listed you are sure to find the part you need.

Feel free to visit us today at our online store:

LittleDiode.com

Looking forward to providing you with the best possible service.