

# AN2034FAP

## CCD Video Camera Signal Processor IC

### Overview

The AN2034FAP is a signal processor IC for a video camera. Receiving CDS signals, it performs AGC and  $\gamma$  correction, and outputs combined luminance and color signal.

### Features

- Operating on low voltage ( $V_{CC} = 4.8V$ )
- 1.3 and 3.3V outputs for AD converter reference

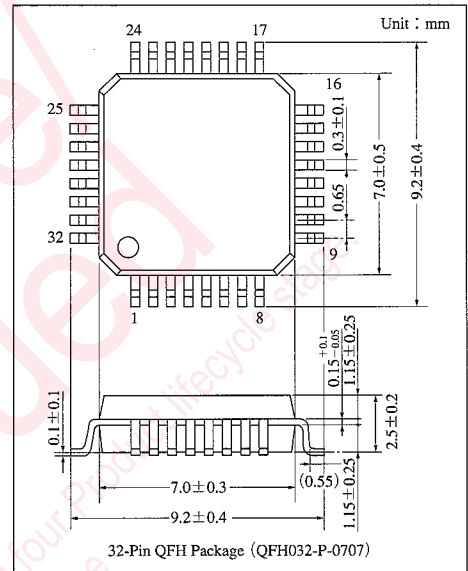

### Block Diagram

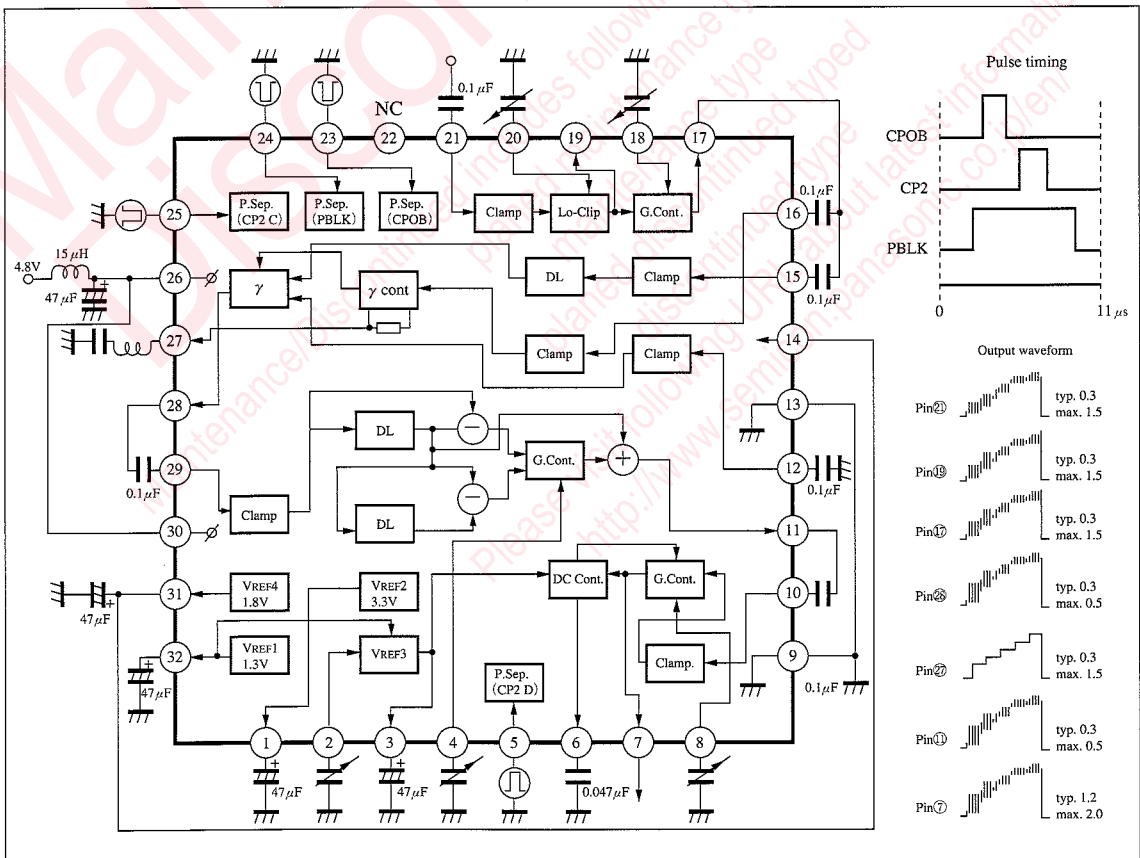

## Absolute Maximum Ratings

Parameter	Symbol	Rating	Unit
Supply voltage	$V_{CC}$	5.5	V
Supply current	$I_{CC}$	—	mA
Power dissipation <sup>Note 2)</sup>	$P_D$	200	mW
Operating ambient temperature <sup>Note 1)</sup>	$T_{opr}$	-20 to +70	°C
Storage temperature <sup>Note 1)</sup>	$T_{stg}$	-55 to +125	°C

Note 1)  $T_a=25^\circ\text{C}$  except operating ambient temperature and storage temperature unless otherwise specified.

Note 2) Allowable power dissipation of the package at  $T_a=70^\circ\text{C}$ .

## Recommended Operating Range ( $T_a=25^\circ\text{C}$ )

Parameter	Symbol	Range
Operating supply voltage range	$V_{CC}$	4.5V to 5.1V

## Electrical Characteristics ( $T_a=25\pm 2^\circ\text{C}$ )

Parameter	Symbol	Condition	min	typ	max	Unit
Total circuit current	$I_{tot}$	$V_{26}=4.8\text{V}$ , $V_{30}=4.8\text{V}$	20	30	40	mA
Reference voltage (1)	$V_{REF1}$	$V_{26}=4.8\text{V}$ , $V_{30}=4.8\text{V}$	1.22	1.32	1.42	V
Reference voltage (2)	$V_{REF2}$	$V_{26}=4.8\text{V}$ , $V_{30}=4.8\text{V}$	3.22	3.32	3.42	V
Reference voltage (3)	$V_{REF3}$	$V_{26}=4.8\text{V}$ , $V_{30}=4.8\text{V}$	1.74	1.84	1.94	V
Pulse separation (1)	CPOB	$V_{26}=4.8\text{V}$ , $V_{30}=4.8\text{V}$	2.4	2.7	2.9	V
Pulse separation (2)	CP2	$V_{26}=4.8\text{V}$ , $V_{30}=4.8\text{V}$	2.4	2.7	2.9	V
Pulse separation (3)	PBLK	$V_{26}=4.8\text{V}$ , $V_{30}=4.8\text{V}$	1.2	1.5	1.8	V
AGC f-characteristics	$G_{FA}$	10MHz with BLK below sine wave 300mV <sub>P-P</sub>	-3.0	-0.5	1.5	dB
AGC level adjustment	$V_{ADJ}$	10step 300mV <sub>P-P</sub>	0.9	1.35	1.8	V
AGC output D range	$V_{AG3}$	10step 1.2V <sub>P-P</sub>	1000	1200	1400	mV <sub>P-P</sub>
AGC max gain	$G_{AG}$	10step 100mV <sub>P-P</sub>	18.5	21.0	24.0	dB
Pre-Aperture corr. output D range	$V_{PR1}$	10step 1.2V <sub>P-P</sub>	1000	1200	1400	mV <sub>P-P</sub>
Pre-Aperture corr. gain (1)	$G_{PR1}$	8MHz with BLK below sine wave 300mV <sub>P-P</sub>	3.5	5.0	6.5	dB
Pre-Aperture corr. gain (2)	$G_{PR2}$	8MHz with BLK below sine wave 300mV <sub>P-P</sub>	-5.0	-2.2	-1.0	dB
Pre-Aperture corr. gain (3)	$G_{PR3}$	8MHz with BLK below sine wave 300mV <sub>P-P</sub>	2.5	5.5	8.0	dB
$\gamma$ f-characteristics	$G_{FG}$	10MHz with BLK below sine wave 300mV <sub>P-P</sub>	-3.0	-0.5	1.5	dB
$\gamma$ characteristics (1)	$V_{GM1}$	10step 300mV <sub>P-P</sub>	80	100	120	mV <sub>P-P</sub>
$\gamma$ characteristics (2)	$G_{GM2}$	10step 300mV <sub>P-P</sub>	5.0	6.0	7.0	dB
$\gamma$ characteristics (3)	$G_{GM3}$	10step 300mV <sub>P-P</sub>	8.5	9.5	10.5	dB
$\gamma$ characteristics (4)	$G_{GM4}$	10step 1.5V <sub>P-P</sub>	1.0	2.5	4.0	dB
$\gamma$ characteristics (5)	$V_{GH}$	10step 1.5V <sub>P-P</sub>	40	—	—	mV <sub>P-P</sub>
Output amp. f-characteristics	$G_{FB}$	10MHz with BLK below sine wave 300mV <sub>P-P</sub>	-3.0	-0.5	1.5	dB
Output amp. gain (1)	$V_{AD1}$	10step 300mV <sub>P-P</sub>	900	1100	1300	mV <sub>P-P</sub>
Output amp. gain (2)	$G_{AD2}$	10step 300mV <sub>P-P</sub>	-5.5	-2.5	-1.0	dB
Output amp. gain (3)	$G_{AD3}$	10step 300mV <sub>P-P</sub>	1.5	4.0	6.5	dB

Pin Descriptions

Pin No.	Symbol	Equivalent circuit	Pin voltage	Pin No.	Symbol	Equivalent circuit	Pin voltage
1	V <sub>REF2</sub> OUT	—	3.3V	6	DC— Cont.C		—
2	OBA <sub>Adj.</sub>		1.3V to 3.3V	7	A/D OUT		1.5V  (15Ω)
3	V <sub>REF3</sub> OUT		1.2V to 1.5V	8	Output amp. G. Cont		—
4	Pre—Apa GC		—	9	GND1	—	—
5	CP2 IN		Thresh 2.7V	10	Output amp. IN		1.8V clamp

ICs for  
Video  
Camera

Note) A value in parentheses means impedance.

■ Pin Descriptions (cont.)

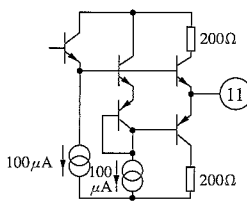
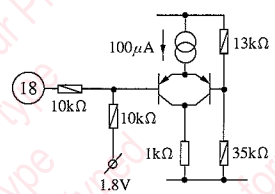
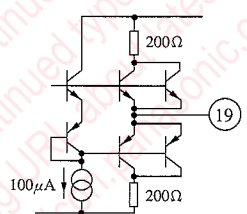
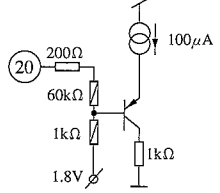
Pin No.	Symbol	Equivalent circuit	Pin voltage	Pin No.	Symbol	Equivalent circuit	Pin voltage
11	Pre-Apa. OUT		1.7V (60Ω)	16	$\gamma$ Cont. IN	Same as for Pin⑩	—
12	DUMMY	Same as for Pin⑩	—	17	AGC OUT	Same as for Pin⑪	—
13	GND 2	—	—	18	AGC Cont.		—
14	V <sub>REF4</sub> IN	—	—	19	AF OUT		—
15	$\gamma$ SIG IN	Same as for Pin⑩	—	20	PEDE Adj.		—

Note) A value in parentheses means impedance.

■ Pin Descriptions (cont.)

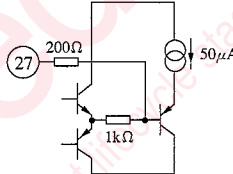
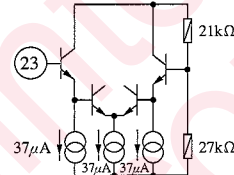
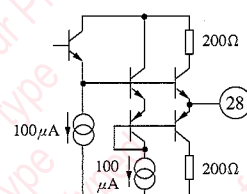
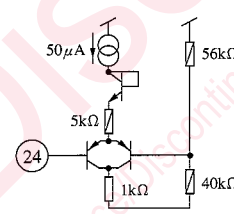
Pin No.	Symbol	Equivalent circuit	Pin voltage	Pin No.	Symbol	Equivalent circuit	Pin voltage
21	(CDS- OUT) IN	Same as for Pin⑩	—	26	V <sub>CC1</sub>	—	—
22	NC	(Surge diode only)	—	27	Trap OUT		—
23	CPOB IN		Thresh 2.7V	28	γOUT		—
24	PBLK IN		Thresh 1.5V	29	Pre-Apa. IN	Same as for Pin⑩	—
				30	V <sub>CC2</sub>	—	—
25	CP2IN	Same as for Pin⑭	Thresh 2.7V	31	V <sub>REF4</sub> OUT	—	1.8V
				32	V <sub>REF1</sub> OUT	—	1.3V

ICs for  
Video  
Camera

## Pin Descriptions

Pin No.	Pin name	Pin No.	Pin name
1	V <sub>REF2</sub> OUT (3.3V)	17	AGC OUT
2	OB adj	18	AGC Cont
3	V <sub>REF3</sub> OUT	19	AF OUT
4	Pre Apa G. Cont	20	Pedestal adjustment
5	CP2 IN	21	(CDS - OUT) IN
6	DC Cont - C	22	No connection (surge diode only)
7	A/D OUT	23	CPOB IN
8	Output amp. G. Cont.	24	PBLK IN
9	GND1	25	CP2 IN
10	Output amp. IN	26	V <sub>CC1</sub>
11	Pre Apa OUT	27	Trap OUT
12	DUMMY Clamp	28	γOUT
13	GND2	29	Pre-aperture corr. IN
14	V <sub>REF4</sub> IN	30	V <sub>CC2</sub>
15	γSIG IN	31	V <sub>REF4</sub> OUT (1.8V)
16	γCont IN	32	V <sub>REF1</sub> OUT (1.3V)

## Reference

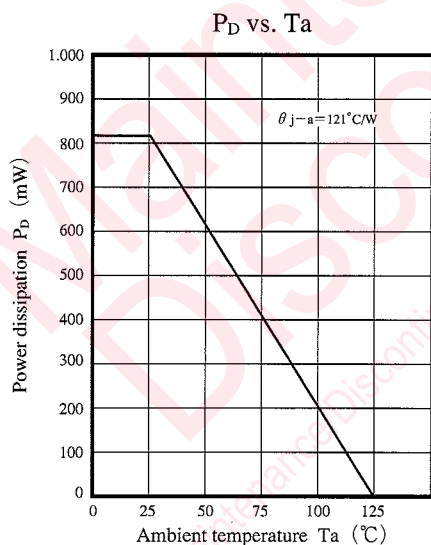

■ Reference (cont.)

Pedestal characteristics

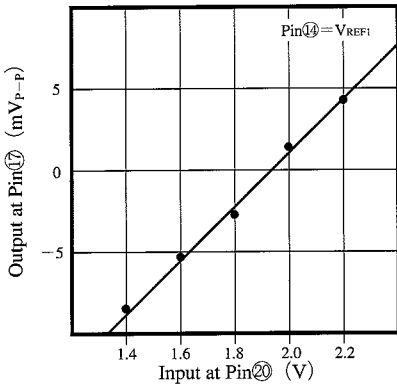

OB adjustment characteristics

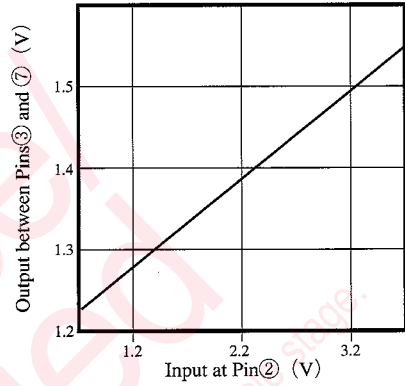

AGC characteristics

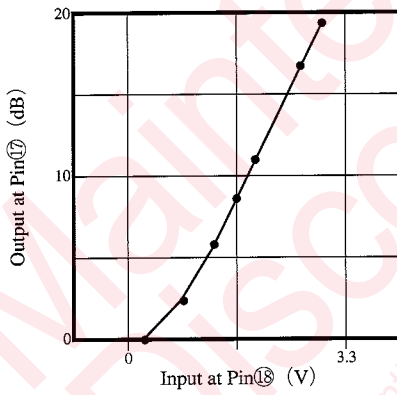

Pre Apa. gain control

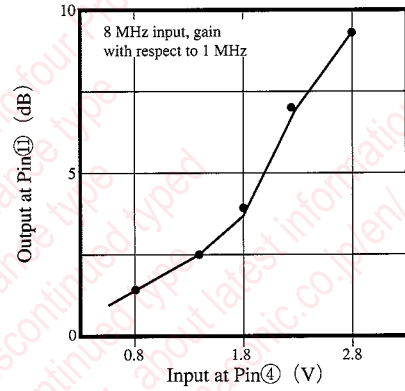

Output amp. gain control

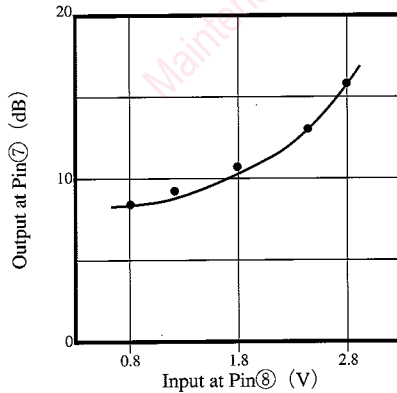

ICs for Video Camera

## Request for your special attention and precautions in using the technical information and semiconductors described in this book

- (1) If any of the products or technical information described in this book is to be exported or provided to non-residents, the laws and regulations of the exporting country, especially, those with regard to security export control, must be observed.
- (2) The technical information described in this book is intended only to show the main characteristics and application circuit examples of the products. No license is granted in and to any intellectual property right or other right owned by Panasonic Corporation or any other company. Therefore, no responsibility is assumed by our company as to the infringement upon any such right owned by any other company which may arise as a result of the use of technical information described in this book.
- (3) The products described in this book are intended to be used for standard applications or general electronic equipment (such as office equipment, communications equipment, measuring instruments and household appliances).  
Consult our sales staff in advance for information on the following applications:
  - Special applications (such as for airplanes, aerospace, automobiles, traffic control equipment, combustion equipment, life support systems and safety devices) in which exceptional quality and reliability are required, or if the failure or malfunction of the products may directly jeopardize life or harm the human body.
  - Any applications other than the standard applications intended.
- (4) The products and product specifications described in this book are subject to change without notice for modification and/or improvement. At the final stage of your design, purchasing, or use of the products, therefore, ask for the most up-to-date Product Standards in advance to make sure that the latest specifications satisfy your requirements.
- (5) When designing your equipment, comply with the range of absolute maximum rating and the guaranteed operating conditions (operating power supply voltage and operating environment etc.). Especially, please be careful not to exceed the range of absolute maximum rating on the transient state, such as power-on, power-off and mode-switching. Otherwise, we will not be liable for any defect which may arise later in your equipment.
  - Even when the products are used within the guaranteed values, take into the consideration of incidence of break down and failure mode, possible to occur to semiconductor products. Measures on the systems such as redundant design, arresting the spread of fire or preventing glitch are recommended in order to prevent physical injury, fire, social damages, for example, by using the products.
- (6) Comply with the instructions for use in order to prevent breakdown and characteristics change due to external factors (ESD, EOS, thermal stress and mechanical stress) at the time of handling, mounting or at customer's process. When using products for which damp-proof packing is required, satisfy the conditions, such as shelf life and the elapsed time since first opening the packages.
- (7) This book may be not reprinted or reproduced whether wholly or partially, without the prior written permission of our company.



LittleDiode supplies new, hard to find or obsolete electronic components and semiconductors all over the world.

With over two million different components listed you are sure to find the part you need.

Feel free to visit us today at our online store:

[LittleDiode.com](http://LittleDiode.com)

Looking forward to providing you with the best possible service.