

AN1833, AN1833S

Low Noise, High Slew Rate Operational Amplifiers

Outline

The AN1833 and the AN1833S are low noise, high slew rate type dual operational amplifiers with phase compensation circuits built-in. They have wide band and high stability, and suited for application to various electronic circuits such as active filters and audio preamplifiers.

Features

- Phase compensation circuit
- High gain : $G_v = 110\text{dB}$ typ.
- Low noise : $V_{ni} = 0.9\mu\text{Vrms}$ typ.
- High slew rate : $SR = 6\text{V}/\mu\text{s}$ typ.
- High stability

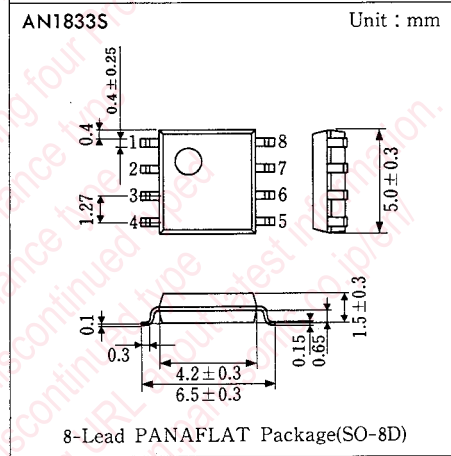
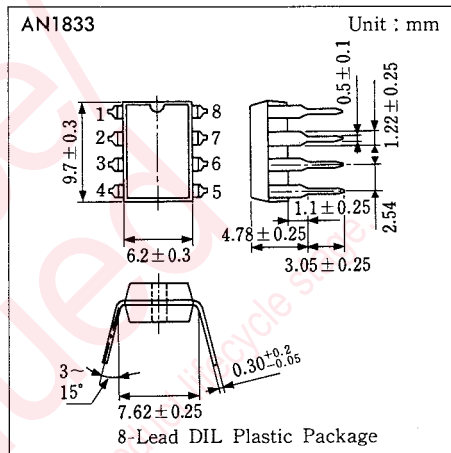

Block Diagram

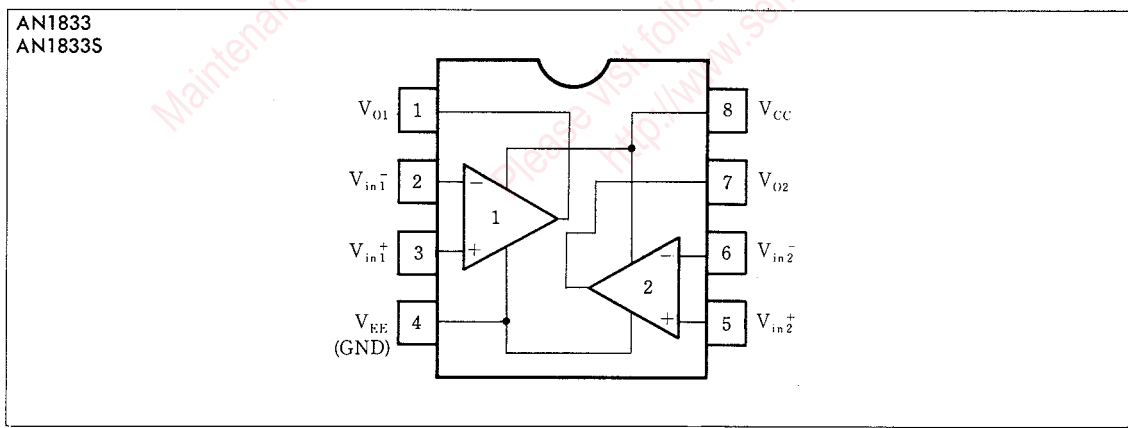

■ Pin

Pin No.	Pin Name
1	Ch. 1 Output
2	Ch. 1 Invert Input
3	Ch. 1 Non Invert Input
4	V _{EE} (GND)
5	Ch. 2 Non Invert Input
6	Ch. 2 Invert Input
7	Ch. 2 Output
8	V _{CC}

■ Absolute Maximum Ratings (T_a = 25°C)

Item		Symbol	Rating	Unit
Voltage	Supply Voltage	V _{CC}	±18	V
	Differential Input Voltage	V _{ID}	±30	V
	Common-Mode Input Voltage	V _{ICM}	±15	V
Power Dissipation	AN1833	P _D	500	mW
	AN1833S		360	
Operating Ambient Temperature		T _{opr}	-20 ~ +75	°C
Storage Temperature	AN1833	T _{stg}	-55 ~ +150	°C
	AN1833S		-55 ~ +125	

■ Electrical Characteristics (V_{CC} = 15V, V_{EE} = -15V, T_a = 25°C)

Item	Symbol	Test Circuit	Condition	min.	typ.	max.	Unit
Input Offset Voltage	V _{I(offset)}	1	R _S ≤ 10kΩ		0.3	5	mV
Input Offset Current	I _{IO}	1			5	200	nA
Input Bias Current	I _{Bias}	1			300	1000	nA
Voltage Gain	G _V	1		90	110		dB
Maximum Output Voltage	V _{O(max.)}	2	R _L ≥ 10kΩ	±12	±13.5		V
Maximum Output Voltage	V _{O(max.)}	2	R _L ≥ 2kΩ	±10	±13.4		V
Common-Mode Input Voltage Width	V _{CM}	3		±12	±14		V
Common-Mode Rejection Ratio	CMR	1		80	100		dB
Supply Voltage Rejection Ratio	SVR	1			10	100	dB
Power Consumption	P _C	4	R _L = ∞		150	240	mW
Slew Rate	SR	5	R _L ≥ 2kΩ		6		V/μs
Unity-gain Band Width	f _(T)	6	A _V = 1		7		MHz
Equivalent Input Noise Voltage	V _{ni}	7	R _S = 1kΩ, DIN/AUDIO		0.9		μV _{rms}

Test Circuit 1 ($V_{I(offset)}$, I_{IO} , I_{Bias} , G_V , CMR , SVR)

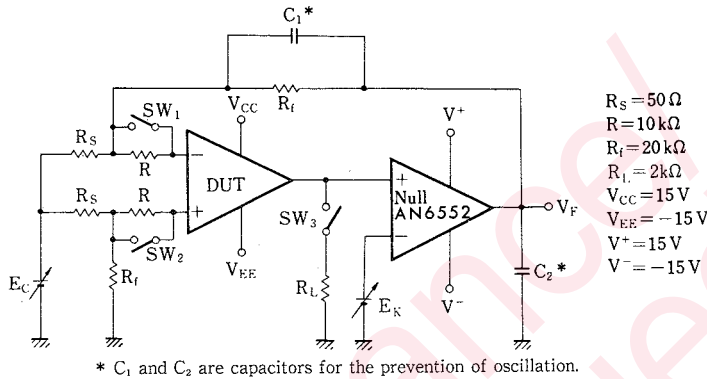

Item	Measurement Conditions
Input Offset Voltage	V_{F1} is measured with the SW_1 , SW_2 and SW_3 set to OFF and $E_C = E_K = 0V$. Can be given by $V_{I(offset)} = \frac{V_{F1}}{400} (V)$
Input Offset Current	V_{F2} is measured with the SW_1 and SW_2 set to ON, the SW_3 set to OFF and $E_C = E_K = 0V$. Can be given by $I_{IO} = \frac{ V_{F2} - V_{F1} }{4 \times 10^6} (A)$
Input Bias Current	V_{F3} is measured with the SW_3 set to OFF, $E_C = E_K = 0V$, the SW_1 set to ON and the SW_2 set to OFF. V_{F4} is measured with the SW_1 and SW_2 reversed. Can be given by $I_{Bias} = \frac{ V_{F3} - V_{F4} }{8 \times 10^6} (A)$
Voltage Gain	V_{F5} is measured with the SW_1 , SW_2 and SW_3 set to ON, $E_C = 0V$ and $E_K = 10V$. V_{F5}' is measured with $E_K = -10V$. Can be given by $G_V = 20 \log \left(\frac{8000}{ V_{F5} - V_{F5}' } \right)$
Common-Mode Rejection Ratio	V_{F6} is measured with both the SW_1 and SW_2 set to ON, the SW_3 set to OFF, $E_K = 0V$ and $E_C = 5V$. V_{F6}' is measured with $E_C = -5V$. Can be given by $CMR = 20 \log \left(\frac{4000}{ V_{F6} - V_{F6}' } \right)$
Supply Voltage Rejection Ratio I	V_{F7} is measured with both the SW_1 and SW_2 set to ON, the SW_3 set to OFF, $E_K = E_C = 0V$ and $V_{CC} = 10V$. Can be given by $SVR(+)= \frac{ V_{F7} - V_{F2} }{2 \times 10^3}$
Supply Voltage Rejection Ratio II	V_{F8} is measured with both the SW_1 and SW_2 set to ON, the SW_3 set to OFF, $E_K = E_C = 0V$ and $V_{EE} = -10V$. Can be given by $SVR(-)= \frac{ V_{F8} - V_{F2} }{2 \times 10^3}$

Note) When not specified in the above table, $V_{CC} = 15V$ and $V_{EE} = -15V$.

Test Circuit 2 ($V_{O(max)}$)

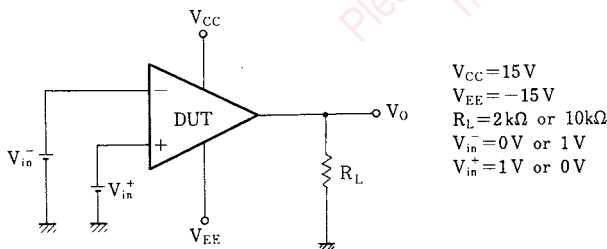

Test Circuit 3 (V_{CM})

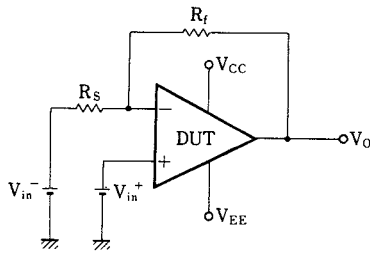

$V_{CC}=15V$
 $V_{EE}=-15V$
 $R_S=200\Omega$
 $R_f=2k\Omega$

Note) Apply a voltage of $|V_{in^+}| > 12V$ and check $V_o = V_{in^+} + \frac{R_f}{R_s}(V_{in^+} - V_{in^-})$

Test Circuit 4 (P_C)

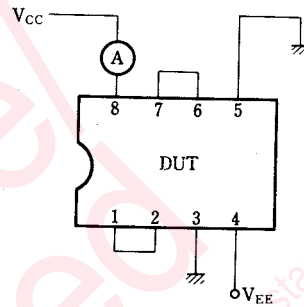

$V_{CC}=15V$
 $V_{EE}=-15V$

Test Circuit 5 (SR)

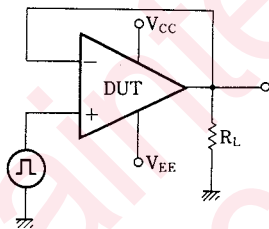

$V_{CC}=15V$
 $V_{EE}=-15V$
 $R_L=2k\Omega$

Test Circuit 6 ($f_{(T)}$)

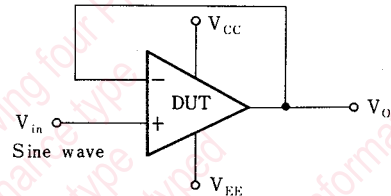

Test Circuit 7 (V_{ni})

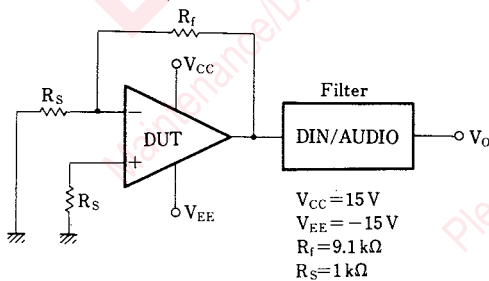

$V_{CC}=15V$
 $V_{EE}=-15V$
 $R_f=9.1k\Omega$
 $R_S=1k\Omega$

Note) A noise voltage referred to Input: $V_{ni} = \frac{V_o}{(1 + R_f/R_s)}$ (V) is given.

$G_v - f$

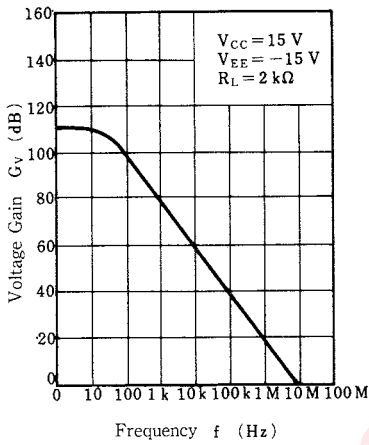

$V_{O(max.)} - f$

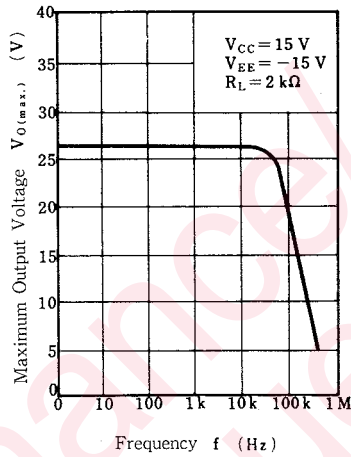

$V_{O(max.)} - R_L$

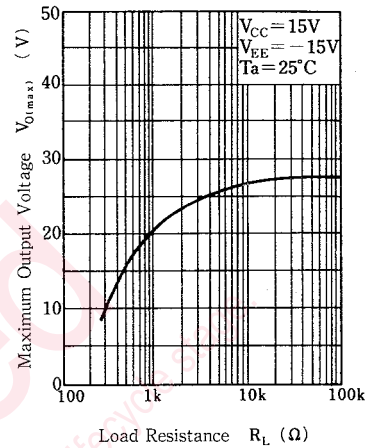

$V_{ni} - f$

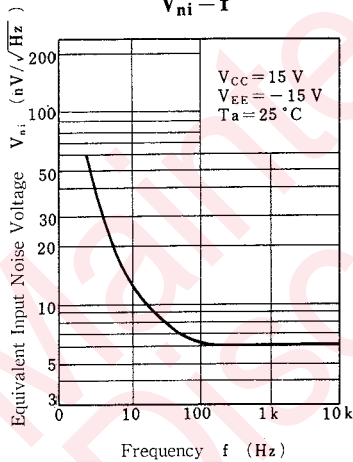

$I_{CC} - V_{CC}$

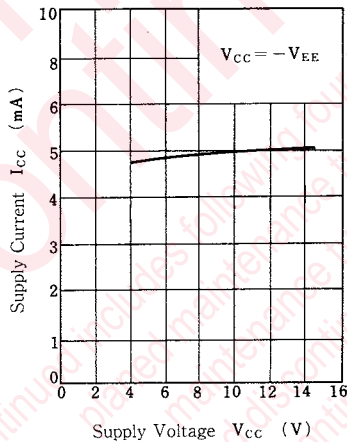

$V_{O(max.)} - V_{CC}$

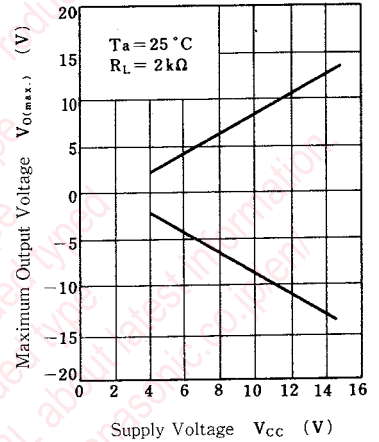

Application Circuit

RIAA Amplifier

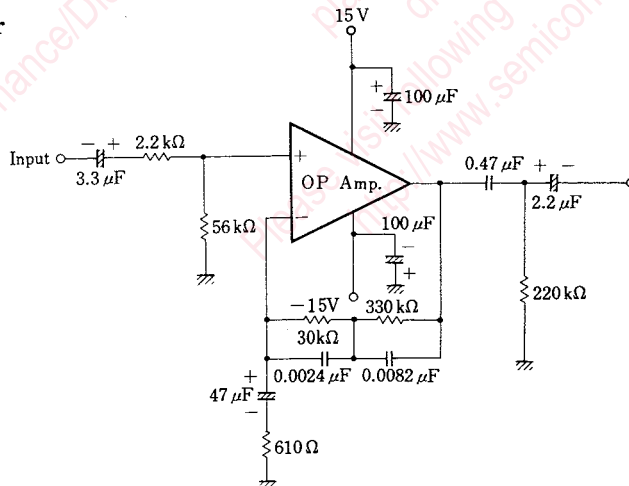

Request for your special attention and precautions in using the technical information and semiconductors described in this book

- (1) If any of the products or technical information described in this book is to be exported or provided to non-residents, the laws and regulations of the exporting country, especially, those with regard to security export control, must be observed.
- (2) The technical information described in this book is intended only to show the main characteristics and application circuit examples of the products. No license is granted in and to any intellectual property right or other right owned by Panasonic Corporation or any other company. Therefore, no responsibility is assumed by our company as to the infringement upon any such right owned by any other company which may arise as a result of the use of technical information described in this book.
- (3) The products described in this book are intended to be used for standard applications or general electronic equipment (such as office equipment, communications equipment, measuring instruments and household appliances).
Consult our sales staff in advance for information on the following applications:
 - Special applications (such as for airplanes, aerospace, automobiles, traffic control equipment, combustion equipment, life support systems and safety devices) in which exceptional quality and reliability are required, or if the failure or malfunction of the products may directly jeopardize life or harm the human body.
 - Any applications other than the standard applications intended.
- (4) The products and product specifications described in this book are subject to change without notice for modification and/or improvement. At the final stage of your design, purchasing, or use of the products, therefore, ask for the most up-to-date Product Standards in advance to make sure that the latest specifications satisfy your requirements.
- (5) When designing your equipment, comply with the range of absolute maximum rating and the guaranteed operating conditions (operating power supply voltage and operating environment etc.). Especially, please be careful not to exceed the range of absolute maximum rating on the transient state, such as power-on, power-off and mode-switching. Otherwise, we will not be liable for any defect which may arise later in your equipment.
 - Even when the products are used within the guaranteed values, take into the consideration of incidence of break down and failure mode, possible to occur to semiconductor products. Measures on the systems such as redundant design, arresting the spread of fire or preventing glitch are recommended in order to prevent physical injury, fire, social damages, for example, by using the products.
- (6) Comply with the instructions for use in order to prevent breakdown and characteristics change due to external factors (ESD, EOS, thermal stress and mechanical stress) at the time of handling, mounting or at customer's process. When using products for which damp-proof packing is required, satisfy the conditions, such as shelf life and the elapsed time since first opening the packages.
- (7) This book may be not reprinted or reproduced whether wholly or partially, without the prior written permission of our company.



LittleDiode supplies new, hard to find or obsolete electronic components and semiconductors all over the world.

With over two million different components listed you are sure to find the part you need.

Feel free to visit us today at our online store:

LittleDiode.com

Looking forward to providing you with the best possible service.