

---

## *Application Note*

---

# ACOUSTIC PATH DESIGN FOR FULL-DUPLEX CELLULAR HANDS-FREE CAR KITS



This application note describes a design procedure coupled with some testing procedures to enable a system designer to implement a low cost full-duplex cellular hands-free system for cars using the CS6422 Enhanced Echo Cancelling IC. This application note focuses on the design of the acoustic path, that is, the path between the acoustic output (AO) and the acoustic input (APO) of the CS6422. The acoustic path contains the speaker driver, the speaker, the air path between the speaker and the microphone, the microphone, and the microphone preamp.

Additionally, a suggested set of CS6422 configuration parameters is presented as well as some system-level tests that can be used to optimize the parameters for a particular environment.

## **1. DESIGN PROCESS AND CONSIDERATIONS**

There are four parts to the hands-free design process: mechanical design, electrical design, echo

canceler coefficient optimization, and testing. This note will investigate all four.

### **1.1 Design Flow**

The design flow for full-duplex systems is as follows:

- 1) Design the mechanical and electrical systems for low distortion, specifically less than 2% THD across frequency.
- 2) Install the equipment in the target test system, usually a car.
- 3) Tweak the mic preamp gain to achieve -9 dB acoustic coupling.
- 4) Load the starting point example CS6422 register configuration.
- 5) Perform parameter optimization tweaking tests.
- 6) Test under actual driving conditions. If necessary, modify speaker/mic placement and test again.

**TABLE OF CONTENTS**

<b>1. DESIGN PROCESS AND CONSIDERATIONS .....</b>	<b>1</b>
1.1 Design Flow .....	1
1.2 Mechanical Design .....	4
1.2.1 Selecting the Acoustic Components .....	4
1.2.1.1 Speaker Requirements .....	4
1.2.1.2 Microphone Requirements .....	4
1.2.1.3 Speaker Housing Requirements .....	5
1.2.2 Placing the Speaker and Microphone .....	5
1.3 Electrical Design .....	5
1.3.1 Selecting the Speaker Driver .....	5
1.3.2 Setting the Speaker Driver Gain .....	6
1.3.3 Volume Control .....	7
1.3.4 Acoustic Coupling .....	8
1.3.5 Setting the Mic Preamp Gain .....	8
1.3.6 Acoustic Sidetone .....	11
1.4 Echo Canceler Parameter Optimization .....	11
1.4.1 Starting Example .....	11
1.4.2 Tweaking the Parameters .....	12
1.4.3 Network Sidetone .....	13
1.4.4 Loop Gain .....	14
1.5 Tests .....	14
1.5.1 Acoustic Coupling .....	15
1.5.1.1 Loop Gain Method .....	15
1.5.1.2 Frequency Response Method .....	17
1.5.2 Acoustic Distortion .....	17
1.5.2.1 Frequency Sweep Test .....	18
1.5.2.2 Buzz Test .....	18
1.5.3 Acoustic ERLE .....	19
1.5.3.1 White Noise RMS Method .....	19
1.5.3.2 Loop Gain Method .....	20
1.5.4 Call Testing and Coefficient Optimization .....	23
1.5.4.1 Far-end single-talk counting .....	23
1.5.4.1.1 Subtest A, EC Convergence Test .....	23
1.5.4.1.2 Subtest B, Half-Duplex to Full-Duplex transition time .....	24
1.5.4.1.3 Subtest C, Transmit Suppression test .....	24
1.5.4.2 Double-talk .....	24
1.5.4.3 Half-duplex alternate counting .....	25

---

**Contacting Cirrus Logic Support**

For a complete listing of Direct Sales, Distributor, and Sales Representative contacts, visit the Cirrus Logic web site at:  
<http://www.cirrus.com/corporate/contacts/>

---

Preliminary product information describes products which are in production, but for which full characterization data is not yet available. Advance product information describes products which are in development and subject to development changes. Cirrus Logic, Inc. has made best efforts to ensure that the information contained in this document is accurate and reliable. However, the information is subject to change without notice and is provided "AS IS" without warranty of any kind (express or implied). No responsibility is assumed by Cirrus Logic, Inc. for the use of this information, nor for infringements of patents or other rights of third parties. This document is the property of Cirrus Logic, Inc. and implies no license under patents, copyrights, trademarks, or trade secrets. No part of this publication may be copied, reproduced, stored in a retrieval system, or transmitted, in any form or by any means (electronic, mechanical, photographic, or otherwise) without the prior written consent of Cirrus Logic, Inc. Items from any Cirrus Logic website or disk may be printed for use by the user. However, no part of the printout or electronic files may be copied, reproduced, stored in a retrieval system, or transmitted, in any form or by any means (electronic, mechanical, photographic, or otherwise) without the prior written consent of Cirrus Logic, Inc. Furthermore, no part of this publication may be used as a basis for manufacture or sale of any items without the prior written consent of Cirrus Logic, Inc. The names of products of Cirrus Logic, Inc. or other vendors and suppliers appearing in this document may be trademarks or service marks of their respective owners which may be registered in some jurisdictions. A list of Cirrus Logic, Inc. trademarks and service marks can be found at <http://www.cirrus.com>.

1.6 Layout Guidelines .....	25
1.6.1 CS6422-specific guidelines .....	25
1.6.2 Car-Kit guidelines .....	26
1.6.2.1 +5VA/AGND Components .....	26
1.6.2.2 +5VD/DGND Components .....	26
1.6.2.3 +12VBATT/BATTGND Components .....	27
1.7 Quick list of important points: .....	27
1.7.1 Reset and configuration timing .....	27
1.7.2 Distortion .....	27
1.7.3 Speaker/mic placement .....	27
1.7.4 Acoustic coupling .....	28
1.7.5 Training sequence .....	28
<b>2. APPENDIX - EXAMPLE SPEAKER DRIVER CIRCUITS .....</b>	<b>29</b>
2.1 Example 1: TDA1519A -- 15 Watts into 4 W .....	29
2.2 Example 2: TDA2003 -- 3 Watts into 4 W .....	29
2.3 Example 3: TDA1905 -- 2.5 Watts into 4 W .....	33
2.4 Example 4: LM1877-- 2 Watts into 4 W .....	34
2.5 Example 5: LM4861-- 1 Watt into 4 W .....	34

## LIST OF FIGURES

Figure 1. Speaker Distortion .....	4
Figure 2. Speaker Driver Distortion.....	6
Figure 3. Generic Speaker Driver Configuration .....	7
Figure 4. Using RVol to Implement Volume Control .....	7
Figure 5. Three Common Sources of Acoustic Path Distortion.....	9
Figure 6. Acoustic Coupling Design Target.....	9
Figure 7. Example Acoustic Coupling Frequency Response .....	9
Figure 8. Setting the Acoustic Coupling .....	10
Figure 9. Loop Gain with Network Sidetone.....	13
Figure 10. Loop Gain Diagram.....	15
Figure 11. Acoustic Coupling Measurement Method .....	16
Figure 12. Example Acoustic Coupling Frequency Response .....	17
Figure 13. Relative THD+N.....	18
Figure 14. Coupling-Weighted THD+N .....	19
Figure 15. Acoustic ERLE Measurement -- Train the AEC .....	21
Figure 16. Acoustic ERLE Measurement -- Freeze AEC .....	22
Figure 17. Acoustic ERLE Measurement -- Clear AEC.....	22
Figure 18. Suggested CS6422 Layout .....	25
Figure 19. Speaker Driver Implementation .....	26
Figure 20. CS6422 Reset and Configuration Timing .....	27
Figure 21. Example 4 kHz, 3-Pole Butterworth Low-Pass Filter .....	30
Figure 22. TDA 1519A Schematic.....	31
Figure 23. TDA 2003 Schematic .....	32
Figure 24. TDA 1905 Schematic .....	33
Figure 25. LM 1877 Schematic .....	35
Figure 26. LM 4861 Schematic .....	36

## 1.2 Mechanical Design

The performance of full-duplex hands-free designs is strongly influenced by the mechanical hardware, far more so than comparable half-duplex systems. Upgrading a half-duplex design by adding a full-duplex echo controller without changing the half-duplex mechanical hardware typically results in a system whose performance is unacceptable. This section describes the critical parameters of the mechanical design that ensure quality full-duplex operation.

The mechanical design consists of speaker and microphone component selection, speaker housing and mounting, and speaker and microphone placement in the car..

### 1.2.1 Selecting the Acoustic Components

#### 1.2.1.1 Speaker Requirements

The quality of the speaker in a full-duplex system is critical to system performance because echo cancelers are sensitive to signal distortion. Because the echo canceler uses a linear filter to model the acoustic path, the acoustic path to be modeled must be linear in order for the echo canceler to work well. The total worst-case distortion in the acoustic path, which includes the speaker driver, the speaker, the microphone, and the microphone preamp, should be less than 2% THD across frequency.

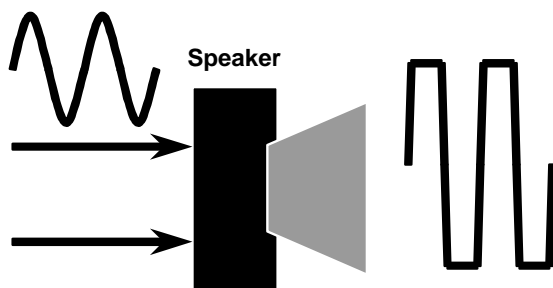


Figure 1. Speaker Distortion

The speakers in automotive hands-free systems are typically driven with a maximum RMS power between 0.5 and 5 Watts. In order to maintain 2% THD or less, it is necessary to install a speaker whose RATED power is at least twice as large as the maximum power to be driven. For example, if we wish to drive 2 Watts into the speaker, then the speaker's RATED power should be 4 Watts or greater. The RATED power of a speaker is the power at which the distortion performance is specified. The typical distortion specification for a speaker operating at its RATED power is either 5% or 10% THD, depending on how the manufacturer specifies distortion.

Speakers are also specified with a MAX power rating. The MAX power is the power level above which the speaker can be damaged. The RATED power, if it is given, is typically about half as large as the MAX power. Thus if the RATED power is not given, a good rule is to assume that the RATED power is about half of the MAX power.

NOTE: The above RATED power/MAX power generalization does not hold for new generation ultra-thin Mylar speakers. The poor distortion performance of these thin speakers makes them unsuitable for full-duplex car designs. Thick speakers exhibit a more linear behavior than thin speakers of equal diameter and are preferred in full-duplex designs.

#### 1.2.1.2 Microphone Requirements

Less care is needed in microphone selection than in speaker selection. Almost any standard inexpensive electret microphone will work because microphones are inherently fairly linear devices. Microphones that cancel background noise due to their mechanical construction are preferred over those that do not. Microphones that are omnidirectional are preferred over those that are directional.

### *1.2.1.3 Speaker Housing Requirements*

The quality of the speaker housing affects the performance of the system because the speaker can induce vibrations in its housing if it is not properly mounted. These vibrations tend to create “buzzing” artifacts which are not linear and result in poor echo canceler performance.

Speakers that are supplied after-market in a housing and speakers that are part of the car's radio system generally do not present problems. It is the speakers that are glued or otherwise rigidly affixed to their plastics that create nonlinear buzzing artifacts.

Speakers should be soft-mounted to their housings by using soft pliable acoustic foam. Care should be taken to minimize any physical means by which the speaker can induce vibrations in the plastics.

The *Test* section contains a test procedure for testing and eliminating buzzing artifacts.

### *1.2.2 Placing the Speaker and Microphone*

The placement of the speaker and the microphone affects the gain selection portion of the electrical design of the system which will be covered shortly. The microphone should be placed as close as feasible to the talker's mouth. This maximizes the signal-to-noise ratio (SNR) of the talker's speech. In a car, the optimal place for the microphone is near the rear view mirror, usually attached to the driver's visor.

There are two considerations for the speaker placement. The more important of the two is that the speaker be placed such that there is a minimum of movement in the air space between the speaker and the microphone. This will minimize the number of updates and corrections that the adaptive filter makes during the call, resulting in the transmission of very little residual echo to the

far-end listener. The second consideration is that the speaker should be placed as far from the microphone as possible. This minimizes the acoustic coupling between the speaker and mic and allows the mic preamp gain and speaker driver gain to be maximized.

The optimum placement for the speaker in a car is the top of the dashboard. Whereas this does not minimize the distance between the speaker and the mic, it does limit the changes in the acoustic path, allowing the adaptive filter to update less often, resulting in less residual echo transmission. Other placement options, below the dash, driver's side door, and passenger's side door, favorably decrease the acoustic coupling, but result in the driver or the passengers being positioned directly in the path between the speaker and the microphone.

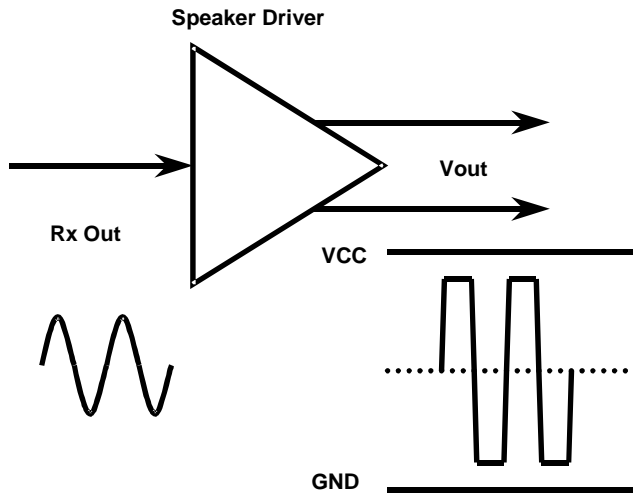
## **1.3 Electrical Design**

The electrical design process consists of the component selection of the speaker driver, the gain selections of the speaker driver and the mic preamp, and the implementation of an acoustic sidetone. The primary design consideration of the electrical design process is to limit the distortion in the acoustic path to less than 2% THD.

### *1.3.1 Selecting the Speaker Driver*

Many system designers overestimate the quality of their speaker drivers. For example, a speaker driver that claims to be “5 Watts” on the cover of its data sheet is not suitable to drive 5 Watts of power into the speaker of a full-duplex echo cancelling system. The reasons are two-fold:

- 1) The “5 Watts” number is usually a Typical number, not a Maximum or a Minimum specification
- 2) “5 Watts” is specified with a THD of 10%, not the 2% number that we are designing to.



**Figure 2. Speaker Driver Distortion**

The Appendix lists five example speaker driver circuits that are suitable for full-duplex hands-free systems.

**1.3.2 Setting the Speaker Driver Gain**

The speaker’s RATED power and the power driven into the speaker are RMS powers. The RMS power is given by the product of the RMS current and the RMS voltage, or the square of the RMS voltage over the speaker resistance.

The maximum speaker driver gain is determined by the square root of the product of the RMS power and the speaker driver resistance:

$$P = V \times I = \frac{V^2}{R}$$

$$V = \sqrt{P \times R}$$

where P = RMS power delivered to speaker, V = RMS voltage across speaker terminals, I = RMS current through speaker, and R = resistance of speaker in Ohms.

$$Gain = \frac{V}{V_{in}}$$

where  $V_{in}$  = full-scale voltage at the AO pin of the CS6422, which is 1 Vrms, or 0 dBV.

Additionally, the gain can be expressed in dB using the following relationship:

$$Gain(dB) = 20 \times \log(Gain)$$

The following example shows how to derive the gain required to drive 2 Watts of RMS power into a 4 Ω speaker. Keep in mind that the RATED power for this speaker should be 4 Watts or greater, and the MAX power should be 8 Watts or greater.

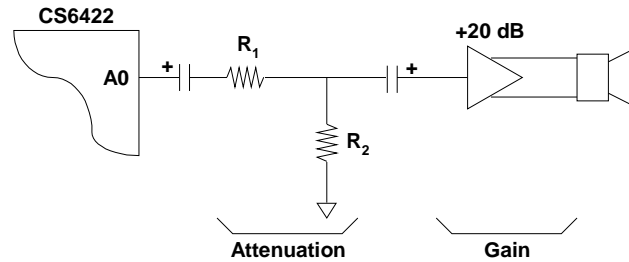
$$P = I \times V = \frac{V^2}{R}$$

$$V = \sqrt{P \times R} = \sqrt{2 \times 4} = \sqrt{8} = 2.828$$

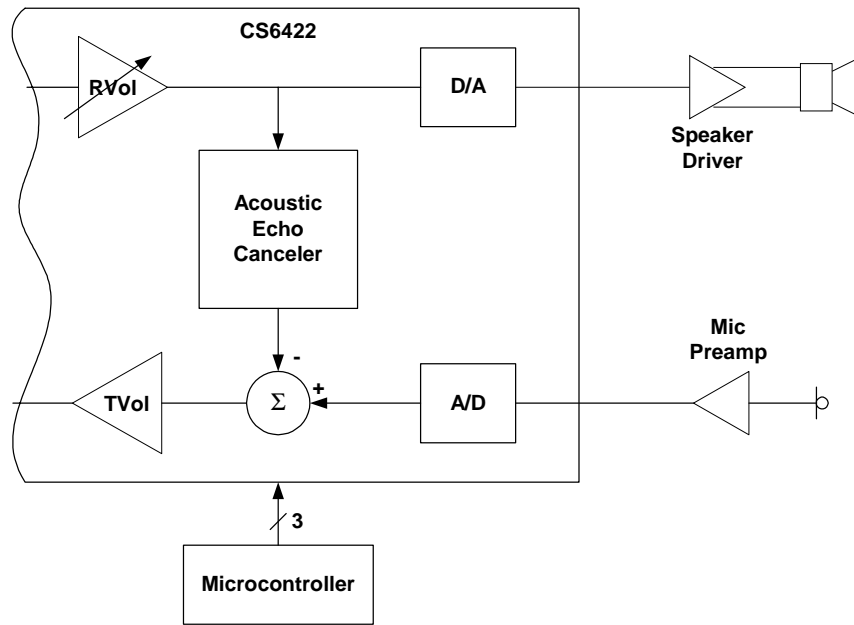
$$Gain = \frac{V}{V_{in}} = \frac{2.828}{1} = 2.828$$

$$Gain(dB) = 20 \times \log(2.828) = 9dB$$

Many speaker drivers suitable for hands-free full-duplex design have fixed gains of 20 dB or more, or are not stable for gains less than 20 dB. Adding 20 dB of gain to the full-scale output of the CS6422 (=1 Vrms, =0 dBV, =2.8 Vpp) results in a huge signal at the speaker terminals (=10 Vrms, =20 dBV, =28 Vpp). Because of this, the speaker driver gain is implemented in two stages, an attenuator stage followed by a gain stage. The attenuator can be implemented using a simple resistor voltage divider network as shown in Figure 3.



**Figure 3. Generic Speaker Driver Configuration**



**Figure 4. Using RVol to Implement Volume Control**

**1.3.3 Volume Control**

In most half-duplex systems, volume control is implemented by changing the gain of the speaker driver. In a full-duplex system, this is undesirable because gain changes in the acoustic path require the echo canceler to readapt, resulting in elevated levels of residual echo during the training process or a temporary drop to half-duplex operation.

In CS6422 systems, it is best to implement volume changes by using the RVol control. The RVol control provides up to +30 dB of AGC'd gain to the receive path, and because the output of the

RVol control is fed both to the echo canceler and to the DAC driving the speaker, changes in RVol do not cause changes in the acoustic path, which keeps the echo canceler from having to readapt. This portion of the signal flow diagram is shown in Figure 4.

In general, the RVol control should be set to a value between +6 dB and +30 dB. In systems which have a network sidetone (a coupling path between NO and NI supplied by the phone), the maximum RVol value may need to be limited due to loop gain concerns. See the sections entitled *Network Sidetone* and *Loop Gain* for more information.

### 1.3.4 Acoustic Coupling

Figure 5 shows the three most common places for distortion to be introduced into the acoustic path. These are the speaker driver, the speaker, and clipping at the A/D converter after the mic preamp. With careful choice of the speaker and speaker driver gain, we can eliminate the first two by using the techniques previously discussed. The third distortion source, clipping at the A/D converter, is controlled by limiting the amount of acoustic coupling.

The acoustic coupling is defined as the gain (or loss) between the AO pin and the APO pin on the CS6422, with TGain set to 0 dB. If TGain is set to a non-zero value, then the TGain value is added to the AO/APO gain number to compute the amount of acoustic coupling.

The acoustic coupling is determined by 5 factors: the speaker driver gain, the speaker efficiency, the air coupling between the speaker and the microphone, the microphone sensitivity, and the mic preamp gain. Assuming the speaker and mic have been chosen, the remaining design variables are the speaker driver gain, the mic preamp gain, and the speaker and mic position.

Usually, the speaker driver gain is chosen based on the linearity requirements previously described. The speaker and mic placement are determined by ergonomic factors and the desired acoustic path stability described above. The remaining variable is the mic preamp gain, which is typically set such that the worst-case acoustic coupling is between -9 dB and -15 dB, the first number being the preferred design target, as shown in Figure 6.

The acoustic path response is highly frequency dependent. The contributions of the speaker driver and the mic preamp to the frequency response are essentially negligible since both of these amplifiers typically have a stable and well-behaved frequency response. The dominant factors in the frequency response of the acoustic path are the speaker's

inherent frequency response, the microphone's inherent frequency response, and the frequency response of the path between the speaker and the mic which is strongly affected by the speaker's housing. The flatter the frequency response, the better the echo cancellation.

Figure 7 shows an example acoustic path frequency response for a speaker and microphone separated by approximately one meter.

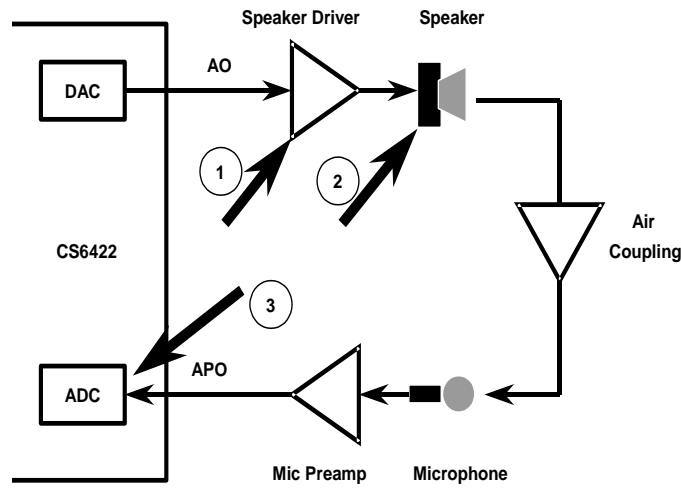
The signal at APO will visibly clip for signals greater than +5 dBV (5 Vpp). Keep in mind that the acoustic A/D converter clips at 0 dBV (2.8 Vpp) when TGain is set to 0 dB.

### 1.3.5 Setting the Mic Preamp Gain

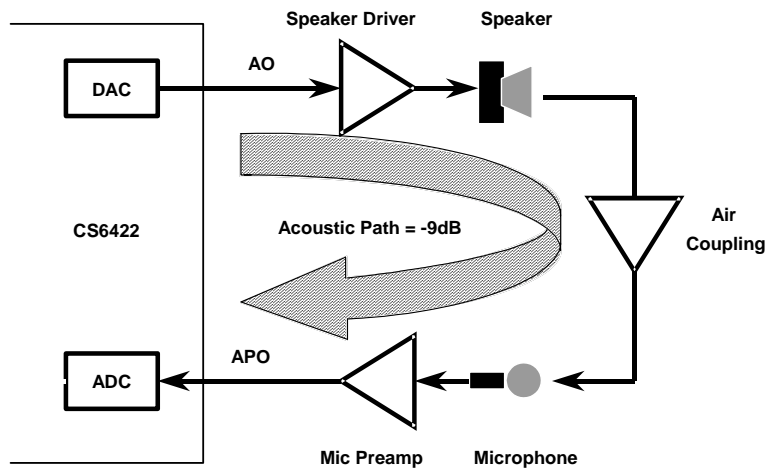
As stated above, the design goal is to have the worst-case value for the acoustic coupling, the highest value across the frequency band of interest, less than or equal to -9 dB. Strictly speaking, it need only be less than 0 dB to avoid clipping at the acoustic A/D converter. The additional 9 dB provides margin for component tolerance variation (dominated by speaker variation), component installation (dominated by speaker/mic placement), and acoustic path variation (dominated by the position of the driver, passengers, and objects in the car). The mic preamp gain is adjusted to achieve the desired level of acoustic coupling.

There are two methods that can be used to set the acoustic coupling: the frequency response method and the loop gain method. The frequency response method is good because it provides frequency response information that can be used to increase the quality of the system (flat frequency response is desired). The loop gain method is quick, easy, and requires no additional test hardware beyond the ability to configure the CS6422's registers.

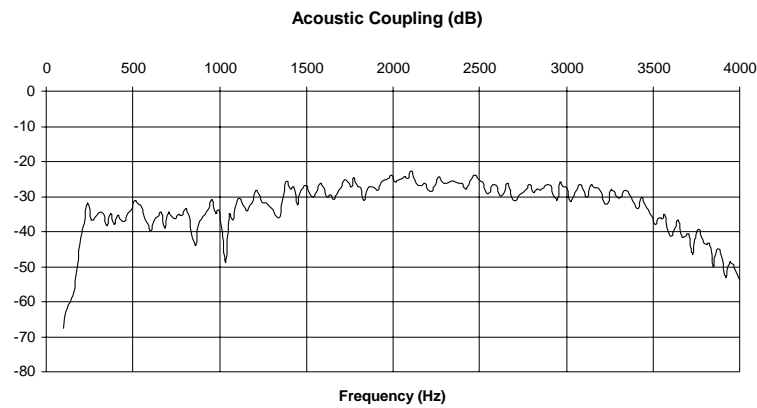
In the frequency response method, the acoustic path frequency response, the gain between the AO and the APO pins on the CS6422, is measured by automated test equipment and plotted. The



**Figure 5. Three Common Sources of Acoustic Path Distortion**



**Figure 6. Acoustic Coupling Design Target**



**Figure 7. Example Acoustic Coupling Frequency Response**

maximum value of this curve is then noted, and gain is added or subtracted at the mic preamp in order to set this maximum value to -9 dBV (with TGain set to 0 dB). This procedure is further described in the *Tests* section of this note.

The loop gain method uses howling to determine the optimum mic preamp gain. In short, the phone network is disconnected from the CS6422, and TVol, RVol and NSdt are used to create a +9 dB path between APO and AO inside the CS6422. The system will howl, go into regenerative feedback, at the point that the total loop gain reaches a factor of '1', or 0 dB. This happens whenever the gain between AO and APO outside the CS6422 reaches -9 dB. The frequency of the howl is the frequency of the maximum loop gain, which is dominated by the speaker, microphone, and the air path between the two. Figure 8 illustrates.

The loop gain procedure is as follows:

- 1) Configure the CS6422 with its default configuration, with the exception of the following:
  - a) *Mic* = '1' or '0', depending on whether the internal mic preamp is used or not
  - b) *TSD* = *RSD* = *HDD* = '1', transmit and receive suppressors and half-duplex mode are disabled
  - c) *ACC* = *NCC* = 'cleared', echo cancelers are forced to a cleared state to prevent updates
  - d) *AECD* = *NECD* = '1', echo cancelers are disabled
  - e) *TVol* = +12 dB
  - f) *NSdt* = -12 dB
  - g) *RVol* = +9 dB
- 2) Adjust the mic preamp gain (or the speaker driver gain) until the system is just on the verge of howling. At this point the gain between AO and APO will be the desired -9 dB.

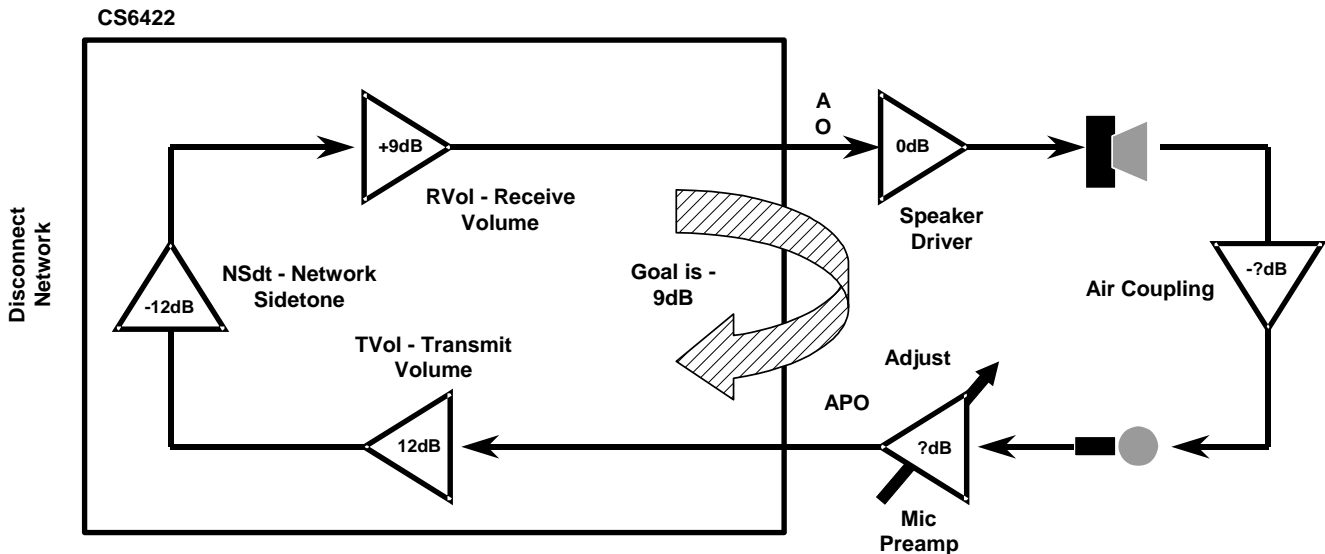


Figure 8. Setting the Acoustic Coupling

The register settings to accomplish the above are as follows:

- reg 0: 47a0 (or c7a0 if internal mic preamp is used)
- reg 1: 26a2
- reg 2: 0004 (default)
- reg 3: 0006 (default)
- reg 4: 0008 (default)
- reg 5: 033a

Note: If the mic preamp gain is not easily adjustable in the test circuit, coarse amounts of gain can be added by using the TGain control, which can be set to 0 dB, +6 dB, +9.5 dB, or +12 dB.

### **1.3.6 Acoustic Sidetone**

When the coupling path between the speaker and the microphone is relatively consistent, linear, and has a high signal-to-noise ratio (SNR), the CS6422 provides good echo cancellation and makes good training decisions. In the car environment, the SNR of the acoustic path can be degraded significantly by road and engine noise and the separation between the speaker and the mic. In these systems, it is often useful to introduce a strong, linear, predictable coupling path electrically by using an acoustic sidetone.

The acoustic sidetone provides 3 main benefits:

- 1) The presence of a strong path decreases convergence time, meaning it decreases the time the CS6422 spends in half-duplex.
- 2) The linear path enhances stability in systems in which the strongest real (air) path is distorted. Note that even though the echo canceller will not cancel the nonlinear elements of the acoustic echo, it will make better decisions regarding when to engage the supplementary suppression algorithms to mask such echo. This results in improved performance during far-end single-talk.

- 3) The consistent path provides an echo path that is independent of the acoustic environment, making the system less sensitive to path changes and noise. This enhances full-duplex performance by reducing the tendency of the CS6422 to drop to half-duplex when the driver moves.

The amount of sidetone required depends on several factors. Typically, a good number is between -24 dB and -12 dB. To be useful, the electrical coupling should be about as strong as the strongest typical air coupling, but not much stronger. A good starting point for systems whose peak acoustic coupling is -9 dB is -18 dB of acoustic sidetone. The acoustic sidetone can be implemented in CS6422 systems by using the ASdt control, which is configurable to none, -24 dB, -18 dB, or -12 dB.

## **1.4 Echo Canceler Parameter Optimization**

One of the benefits of the CS6422 is its high degree of configurability. Whereas the number of parameters may seem daunting at first, there are only a few that need to be tweaked to optimize performance. The rest can be set once and left alone.

### **1.4.1 Starting Example**

The following is an example register configuration that is useful as a starting point for cellular car hands-free systems.

Note: Actual performance testing should be performed in a car, not a lab. This is because the car and the lab present different acoustic environments to the echo canceler, and the goal is to optimize the parameters for the target environment, which requires testing in that target environment.

The following parameter set assumes that there is no coupling on the network interface to the phone. If there is a network coupling path, see the *Network Sidetone* and *Loop Gain* sections below.

Configure the CS6422 from reset with the following:

- 1) *Mic* set to '1' or '0', depending on whether the internal mic preamp is used or not
- 2) *GB* = 0.75 dB/ms
- 3) *RVol* = +18 dB (this is the default setting; *RVol* should be set between +6 dB and +30 dB)
- 4) *Taps* = 55.5 ms
- 5) *TVol* = 0 dB (this is the default setting; close to 0 dB is better; *TVol* should be between 0 dB and +12 dB)
- 6) *NseRmp* = 12 dB/s
- 7) *HDly* = 150 ms
- 8) *IdlTx* = enabled
- 9) *TSAtt* = 24 dB
- 10) *PCSen* = low
- 11) *TSThd* = 12 dB
- 12) *TSBias* = 18 dB (default setting)
- 13) *AErle* = 18 dB
- 14) *AFNse* = -42 dB
- 15) *TGain* = 0 dB (can be 0 dB, +6 dB, +9.5 dB, or +12 dB, depending on mic preamp requirements)
- 16) *NECD* = '1' (should be '0' if a network sidetone is present)
- 17) *ASdt* = -18 dB

The register configuration which implements the above is:

- reg 0: 1400 (9400 if internal mic preamp is used)
- reg 1: 0a22
- reg 2: 0a14
- reg 3: a046
- reg 4: 5008
- reg 5: 018a

### 1.4.2 Tweaking the Parameters

- 1) *TGain* can be set to 0 dB, +6 dB, +9.5 dB, or +12 dB, to add gain to the mic preamp if needed based on acoustic coupling tests.
- 2) *RVol* can be adjusted down or up based on desired signal level. The value should be kept between +6 dB and +30 dB.
- 3) *TVol* can be adjusted to a value between 0 dB and +12 dB to add gain to the transmit path, particularly if the mic preamp gain was reduced to satisfy acoustic coupling requirements.
- 4) *TSThd* controls the ERLE level at which the transmit suppressor engages during far-end single-talk (when the far-end is talking while the near-end listener is silent). This parameter is tested using the Far-End Single-Talk Counting Test described in the *Tests* section.
- 5) *TSBias* controls the ERLE level at which the transmit suppressor disengages during double-talk. Lower values make it easier to disengage the transmit suppressor, preventing the undesirable attenuation of near-end speech. This parameter is tested using the Double-talk test described in the *Tests* section.
- 6) *AErle* and *AFNse* control the behavior of the transition between half-duplex and full-duplex. Specifically, they influence the time it takes for the CS6422 to transition between half-duplex and full-duplex. Lower values of *AErle* tend to decrease the transition time. This parameter is tested using the Full-duplex Transition test described in the *Tests* section.
- 7) *TSAtt* controls the amount of attenuation added to the transmit path when the transmit suppressor engages. This parameter is tested using the Far-End Single Talk Test described in the *Tests* section.
- 8) *IdlTx* causes the half-duplex engine to switch to transmit during an idle period. This parameter only has an effect during half-duplex operation.

This parameter can be tested using the Half-Duplex Alternate Counting Test as described in the *Tests* section.

- 9) *RSD* controls the enable/disable of the receive suppression engine. The receive suppressor is a noise squelch that provides 24 dB of attenuation to the receive path when the far-end talker is silent. The receive suppressor operates in half-duplex and full-duplex modes. When the far-end talker is silent, the signal sent to the speaker drops to almost nothing, that is, background noise is not transmitted. If this is undesirable, the receive suppressor can be disabled by setting *RSD* to '1', allowing the noise to pass to the speaker unattenuated.

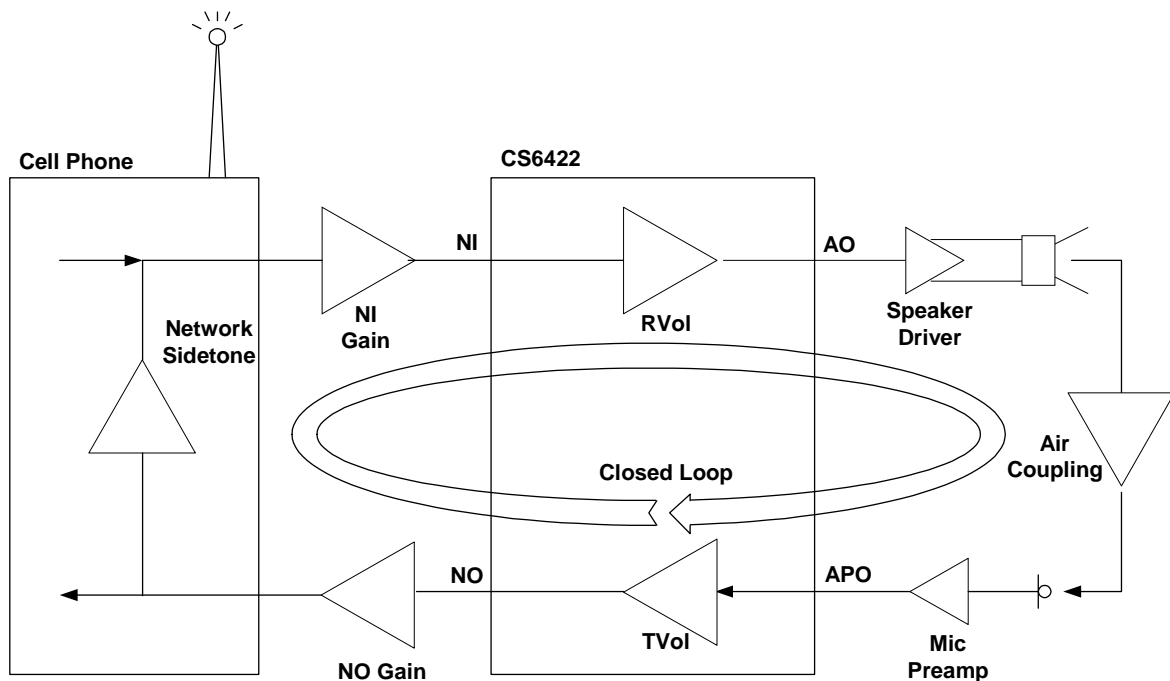
**1.4.3 Network Sidetone**

Some cellular phones provide a coupling path between the network transmit and network receive paths which is used when a full-duplex earpiece and mic are used. This sidetone path provides an

echo between the mic and the earpiece to let the user know that the phone is active, similar to the sidetone supplied by the Central Office in a standard analog phone handset.

The presence of a network sidetone, here defined as a coupling path between the NO pin and the NI pin on the CS6422, increases the complexity of the system considerably because it forms a closed loop with the receive path, the acoustic path, and the transmit path. When a system has a closed loop, care must be taken to ensure that the loop gain of the system remains below a factor of '1', or 0 dB, or howling, regenerative feedback, will result. Figure 9 illustrates.

It is strongly recommended that the network sidetone on the cellular phone be disabled if possible. Most cellular phones that provide only an analog hands-free interface have a means of disabling the sidetone. Cellular phones that provide both analog and digital hands-free interfaces



**Figure 9. Loop Gain with Network Sidetone**

typically employ the sidetone only on the analog interface, leaving the digital interface sidetone-free.

If it is not possible to disable the sidetone or work around it by using a different interface, then the presence of the sidetone must be considered in the design of the system. To minimize the loop gain as well as to prevent the local mic signal from being echoed out the speaker, it is necessary to enable the Network Echo Canceler and to allocate Taps to it. These are the two parameter changes necessary from the recommendations given above. Specifically, NECD should be set to '0', and Taps should be set to either 47.5 ms/16 ms or 39.5 ms/24 ms. Either setting will work; 47.5 ms/16 ms is slightly more desirable since the network path delay inside the phone is easily handled by 16 ms of taps, allowing more taps to be used for modeling the acoustic path.

#### **1.4.4 Loop Gain**

The presence of a network sidetone places constraints on the total loop gain allowed in the system. The network interface gains are determined by matching the full scale level of the phone to the full-scale level of the CS6422. The speaker driver, acoustic coupling, and mic preamp gains are determined as described earlier in this note. The remaining gains are TVol and RVol inside the CS6422.

Note: TGain is treated as part of the mic preamp gain, and RGain is treated as part of the network receive gain.

When the echo cancelers are enabled, they provide additional loss in the loop that is equal to the ERLE (Echo Return Loss Enhancement) of each echo canceler. Because the network path is strong and stable, the ERLE of the network echo canceler can be relied upon to reduce the system loop gain. Because the acoustic path is highly variable, the ERLE of the acoustic echo canceler should NOT be

relied on to reduce the system loop gain.

The network echo canceler can provide, worst case, 15 dB of additional loss in the loop, provided that the network path is linear and lossy, that is, the signal level at NO is reflected back at NI at a lower amplitude than it originated.

Here's an illustrative loop gain example. Assuming that the worst-case acoustic coupling is -9 dB and the network sidetone amplitude, here defined as the gain between the NO and NI pins on the CS6422, is -6 dB, and the network ERLE is 15 dB, then

$$RVol + TVol = 9 + 6 + 15 = 30dB$$

maximum. This +30 dB number can be distributed arbitrarily between RVol and TVol. The placement of the gain does not affect the stability of the system. Usually, the gain is distributed to provide a balance between the transmit path volume and the receive path volume.

#### **1.5 Tests**

In this section, we present some tests which are useful to identify and solve system-level problems. These tests should be performed in the listed order. The first set of tests, Acoustic Coupling, Acoustic Distortion, and Acoustic ERLE, should be performed in a lab and in a car. These tests verify the electrical and the mechanical design of the system.

The last set of tests, which are actual call test scenarios, are used to fine-tune the CS6422 register settings.

NOTE: These tests should be performed in a car.

The latter tests can be performed in a lab, however, it is likely that the set of optimum coefficients derived in lab testing will not be optimal for car use.

**1.5.1 Acoustic Coupling**

The term ‘Acoustic Coupling’ refers to the gain between the AO and the APO pins on the CS6422. It includes the speaker driver gain, the efficiency of the speaker, the loss in the air path between the speaker and the microphone, the sensitivity of the microphone, and the gain of the microphone preamp.

Here we present two methods of measuring the acoustic coupling, the loop gain method and the frequency response measurement method. The loop gain method is quick, easy, and requires no additional test equipment to perform, yet provides only one worst-case coupling number. The frequency response method is more thorough and yields more information, but requires automated test equipment.

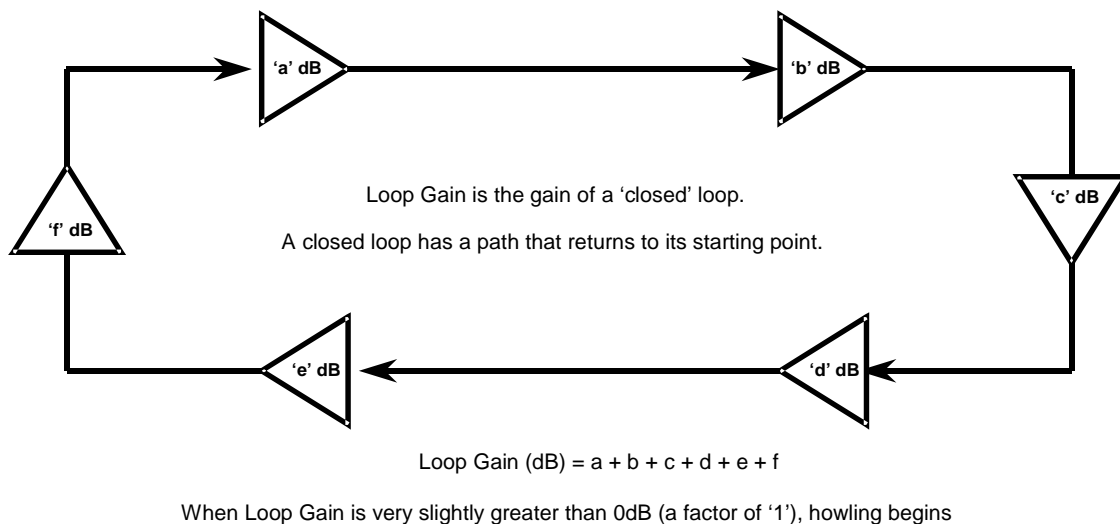
**1.5.1.1 Loop Gain Method**

When a system contains a closed loop whose gain is greater than 1, howling, or regenerative feedback, results. See Figure 10.

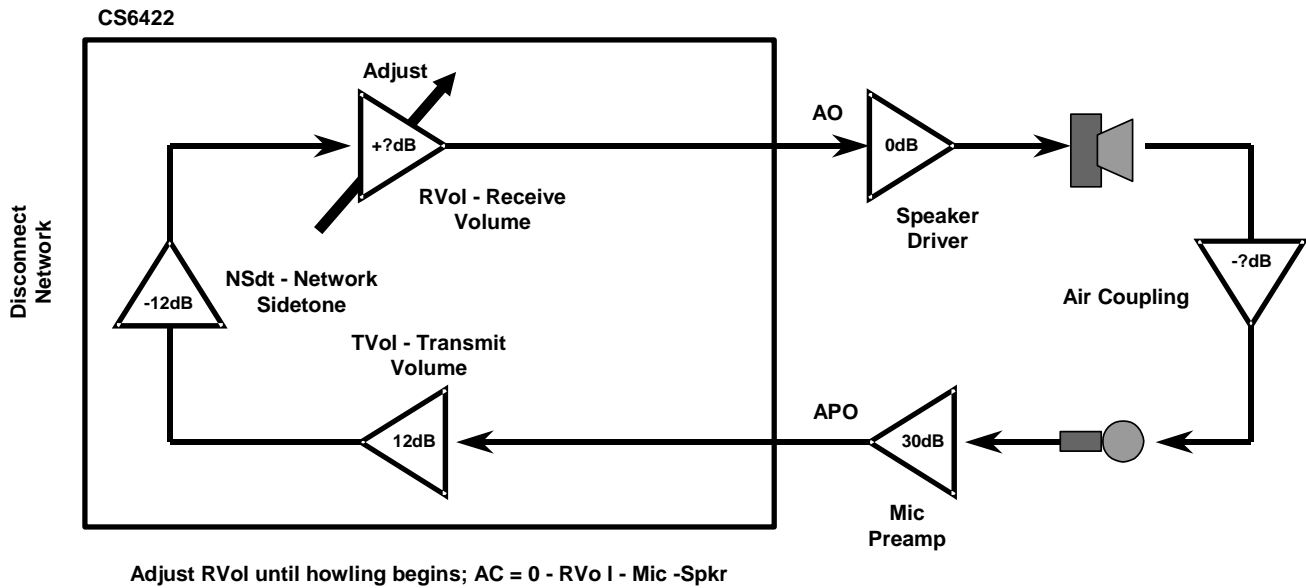
This howling phenomenon can be used to make a quick and accurate measurement of the acoustic coupling between a speaker and a microphone.

In essence, we create a known gain between APO and AO inside the CS6422 using the TVol, NSdt, and RVol controls, and increase this gain until howling results. At the point that howling occurs, the loop gain of the system is 0dB, or a factor of ‘1’.

In this particular example, we set TVol to +12dB, NSdt to -12dB, and increase RVol until howling occurs. The speaker driver gain and mic preamp gain are known, and the remaining unknown, the air coupling between the speaker and the mic, is determined. See Figure 11.



**Figure 10. Loop Gain Diagram**



**Figure 11. Acoustic Coupling Measurement Method**

The loop gain measurement procedure is as follows:

- 1) Configure the CS6422 with its default configuration, with the exception of the following:
  - a) *Mic* = '1' or '0', depending on whether the internal mic preamp is used or not
  - b) *TSD* = *RSD* = *HDD* = '1', transmit and receive suppressors and half-duplex mode are disabled
  - c) *ACC* = *NCC* = 'cleared', echo cancelers are forced to a cleared state to prevent updates
  - d) *AECD* = *NECD* = '1', echo cancelers are disabled
  - e) *TVol* = +12 dB
  - f) *NSdt* = -12 dB
  - g) *RVol* = 0 dB
- 2) Adjust *RVol* until the system is just on the verge of howling. At this point the loop gain is 0 dB, and the loss between AO and APO (outside the CS6422) is equal to the *RVol* value.

The register settings to accomplish the above are as follows:

- reg 0: 4xa0 (or cxa0 if internal mic preamp is used); "x" is the value of *RVol*
- reg 1: 26a2
- reg 2: 0004 (default)
- reg 3: 0006 (default)
- reg 4: 0008 (default)
- reg 5: 033a

*RVol* contains a 4-bit value that results in a gain given by the following equation:

$$Gain(dB) = 30dB - (RVol \times 3dB)$$

For example, if the *RVol* value required to make the system howl is '5', then the loss between AO and APO is (30 - 5 \* 3 = 15 dB)

Physical law ensures that the system will howl at the frequency of maximum coupling. Furthermore,

the frequency of the howl itself is the frequency at which the loop gain, whose frequency response is dominated by the acoustic coupling, is maximum.

**1.5.1.2 Frequency Response Method**

Measuring the frequency response of the acoustic path in the target environment is strongly recommended. In general, the flatter the frequency response, the better the performance of the echo canceler.

In this method, an automated piece of test equipment that contains a variable-frequency sine wave generator coupled with an RMS measurement device, such as an Audio Precision System One or System Two, or a Rohde and Schwarz UPL or UPD is used. Automated equipment is recommended over a manual sine wave generator due to the number of frequency points required (100 or more) and the difficulty of measuring the mic signal due to constructive and destructive interference.

The measurement device’s generator can be connected to the input of the speaker driver or to the NI pin of the CS6422 through a DC-blocking capacitor. If connected to the NI pin, RGain and RVol should each be set to 0 dB, RSD and HDD

should be set to ‘1’, and NCC should be set to ‘cleared’. If connected to the speaker driver input, the connection between the AO pin and the speaker driver should be broken.

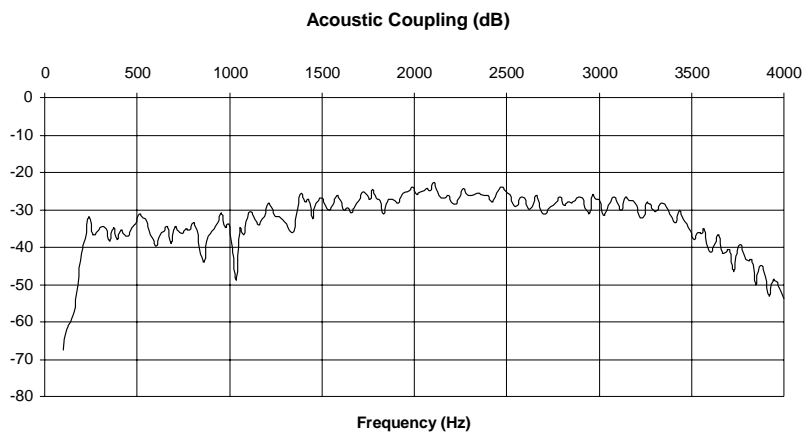
The sine wave generator should be configured to output a 1 Vrms (0 dBV) sine wave that sweeps between 100 Hz and 4 kHz, log distribution is preferred over linear, and samples at least 100 points, preferably 200 or more for this range.

The return signal can be monitored either at the APO pin or the NO pin of the CS6422. If monitored at the NO pin, TSD should be set to ‘1’, and ACC should be set to ‘cleared’. In either case, the Mic bit should be set to ‘1’ if the internal mic preamp is used, or ‘0’ if the internal mic preamp is not being used.

An example acoustic coupling plot is shown in Figure 12.

**1.5.2 Acoustic Distortion**

Earlier in this note, we described a process by which we could limit the distortion in the acoustic path by designing the electrical system carefully. It is still necessary to test the distortion to verify that the distortion level is below 2% THD.



**Figure 12. Example Acoustic Coupling Frequency Response**

There are two tests which should be performed, a Frequency Sweep distortion test and a Buzz test.

*1.5.2.1 Frequency Sweep Test*

In this test, a piece of automated test equipment sweeps a sinewave between 100 Hz and 4 kHz, similar to the Frequency Response Method of testing acoustic coupling. In this test, the input to the analyzer is analyzed for relative THD+N by filtering with a high-Q notch filter at the fundamental frequency of the input. Additionally, a C-message filter or a high-order (5 poles or more) 4 kHz low-pass filter should be applied to keep out-of-band noise from corrupting the measurement.

The resulting curve shows relative THD+N vs. Frequency. An example is shown in Figure 13.

This curve, although useful, is not complete because it lacks information about the coupling strength at each frequency. A relative THD+N reading can be degraded by an increase in the distortion component or a decrease in SNR (which can be caused by a decrease in signal level or an increase in noise level). The residual echo level is dependent only on the amount of distortion. An SNR degradation due to a decrease in signal level

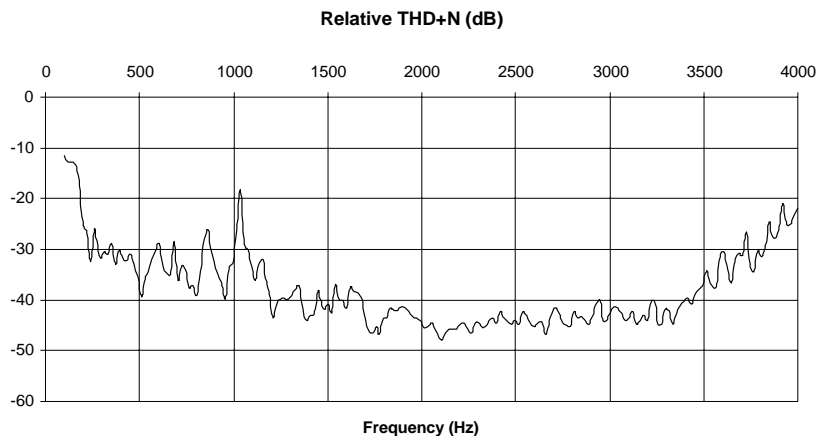
means that there is no echo at those frequencies to cancel.

The graph that we need is a relative THD+N curve that is weighted with the acoustic coupling information. This curve can be constructed by normalizing the acoustic coupling curve by shifting it vertically such that the maximum value is set at 0 dB then adding this normalized curve to the relative THD+N curve. An example is shown in Figure 14. Keep in mind that the goal is to have this weighted distortion curve below 2% THD, or -34 dB at all points.

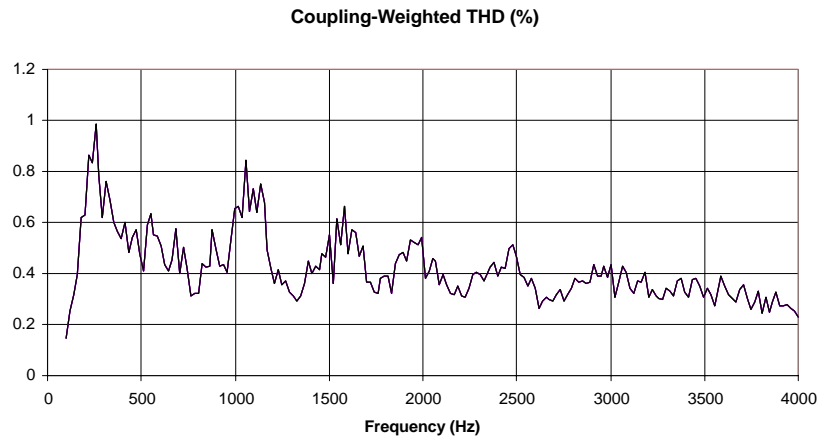
These curves were constructed by saving the data in text format to a file, then importing the information into a spreadsheet for normalization and addition.

*1.5.2.2 Buzz Test*

The distortion measurement method above is designed to detect harmonic distortion resulting from clipping at the speaker driver, the speaker, or the mic preamp. This method is not good at measuring non-harmonic distortion that results when the speaker induces mechanical vibrations in its housing. We refer to these induced vibrations as ‘buzzing’.



**Figure 13. Relative THD+N**



**Figure 14. Coupling-Weighted THD+N**

Similar to harmonic distortion, these ‘buzzing’ artifacts cause elevated levels of residual echo because they result from a non-linear phenomenon that the echo canceler cannot model.

The test for buzzing is similar to the frequency sweep distortion test. A full-scale sine-wave is injected into the speaker-driver input (or the NI input on the CS6422), and swept slowly between 100 Hz and 4 kHz. This sweep can be performed manually. As the frequency is swept, listen for the induced buzzing vibrations. Try placing your hand on the speaker housing to test for mechanical vibrations as well. When a buzz is detected, try to isolate the mechanical cause of the induced vibration and fix it. Typical solutions involve inserting spongy foam gaskets between connecting pieces of plastic or inserting spongy foam between the speaker’s mounting rim and the housing.

### 1.5.3 Acoustic ERLE

In order to tell if the system is properly designed, it is useful to measure the ERLE (Echo Return Loss Enhancement) that the echo canceler is able to provide. We present two methods to test ERLE, the White Noise RMS method and the Loop Gain method.

The White Noise RMS method measures the difference in the spectral power level of the signal with the echo canceler present in the acoustic path and removed. The Loop Gain method measures the worst-case ERLE that the echo canceler is able to achieve by measuring the difference in loop gain with the echo canceler present in the loop versus absent.

Both tests are useful. The White Noise RMS method requires a white noise source and a band-limited RMS voltage measurement instrument. The Loop Gain method requires no additional hardware beyond the ability to configure the CS6422.

#### 1.5.3.1 White Noise RMS Method

In this test, the CS6422 is configured such that the transmit and receive suppressors and half-duplex are disabled. A 2.8 Vpp white noise signal is injected at NI, and the band-limited (preferably C-message) RMS voltage is measured at NO with the echo canceler enabled (ACC = ‘normal’) and disabled (ACC = ‘cleared’).

The test procedure is as follows:

- 1) Set up the speaker and microphone and adjust the acoustic coupling to -9 dB by the methods

discussed earlier in this note.

- 2) Configure the CS6422 from reset with the exception of the following:
  - a) *Mic* set to '1' or '0', depending on whether the internal mic preamp is used or not
  - b) *HDD* = '1'
  - c) *GB* = 0.75 dB/ms
  - d) *TSD* = '1'
  - e) *ACC* = 'Cleared'
  - f) *Taps* = 55.5 ms
  - g) *RSD* = '1'
  - h) *NseRmp* = 12 dB/s
  - i) *PCSen* = 'low'
  - j) *AErle* = 18 dB
  - k) *AFNse* = -42 dB
  - l) *NECD* = '1'
  - m) *ASdt* = -18 dB

The register configuration which implements the above is:

reg 0: 5480 (d480 if internal mic preamp is used)  
 reg 1: 0a82  
 reg 2: 0804  
 reg 3: 2006  
 reg 4: 5008  
 reg 5: 018a

- 3) Inject 2.8 Vpp white noise into NI (capacitively coupled), and measure the RMS signal level at NO. The measured signal should be band-limited with either a C-message filter or at least a 5-pole low-pass filter with a corner frequency of 4 kHz in order to remove out-of-band noise.
- 4) Record the band-limited RMS voltage level at NO.

- 5) Turn OFF the white noise source.
- 6) Set ACC to 'Normal'.
- 7) Turn ON the white noise source.
- 8) Record the band-limited RMS voltage level at NO after 5 seconds or more of white noise.

The ERLE is the difference in dB voltage levels of (8) and (4):

$$ERLE = 20 \times \log(meas(8)) - 20 \times \log(meas(4))$$

The signal at NO can be monitored through headphones to actually hear the echo canceler train to the acoustic path.

If the above tests are to be repeated, it is important to set ACC = 'cleared' and to turn off the white noise source between each test, otherwise results may be inconsistent.

Typical values obtained using the above technique range between -9 dB and -30 dB. In general, the closer together the speaker and mic are and, consequently, the lower the speaker driver gain, the better the performance.

### 1.5.3.2 Loop Gain Method

The loop gain method allows the worst-case ERLE to be determined without the use of a white noise source or an RMS voltage meter. In this method, the adaptive filter is trained on the acoustic path using speech or white noise, its coefficients are then frozen, and a closed loop is formed between TVol, NSdt, RVol, and the acoustic path, which includes the echo canceler. As in the acoustic coupling loop gain test, the receive volume is incremented until howling occurs, and this number is recorded.

The echo canceler coefficients are then cleared, effectively removing the EC from the path, and the receive volume is adjusted again until the point at which howling occurs. This new value is recorded.

The difference between the two RVol values is the worst-case ERLE of the echo canceler. Here is the detailed procedure:

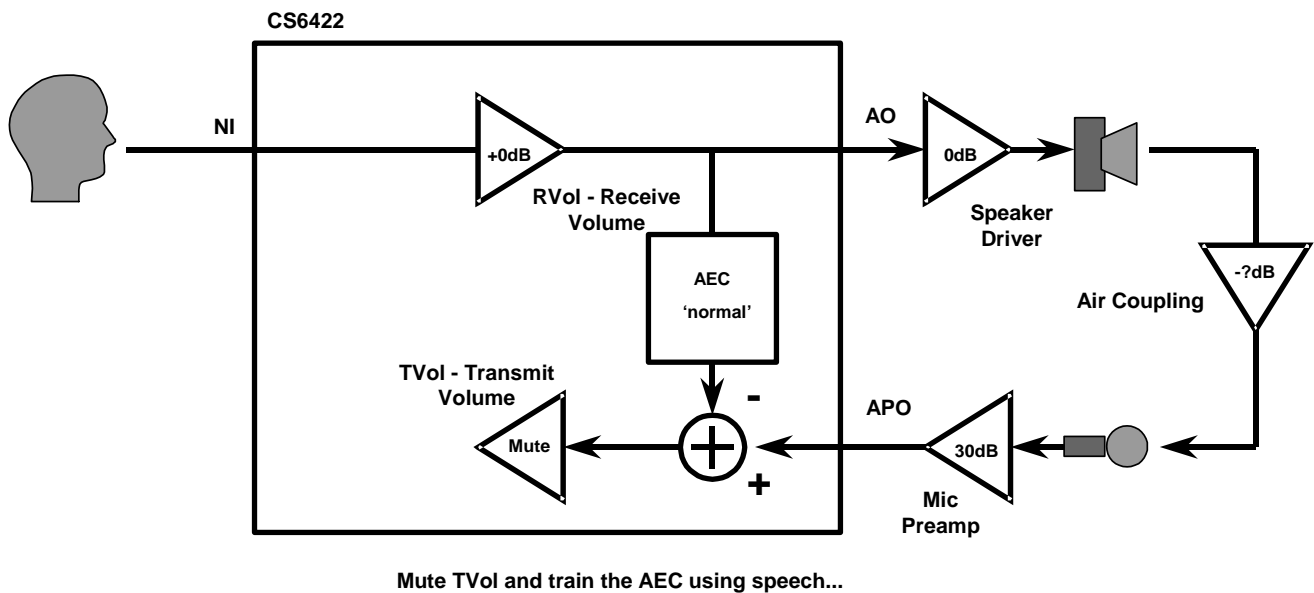
- 1) Set up the speaker and microphone and mic preamp gain for -9 dB of acoustic coupling.
- 2) Configure the CS6422 from reset with the exception of the following:
  - a) *Mic* set to '1' or '0', depending on whether the internal mic preamp is used or not
  - b) *HDD* = '1'
  - c) *GB* = 0.75 dB/ms
  - d) *TSD* = '1'
  - e) *ACC* = 'Cleared'
  - f) *Taps* = 55.5 ms
  - g) *RSD* = '1'
  - h) *NseRmp* = 12 dB/s
  - i) *PCSen* = 'low'
  - j) *AErle* = 18 dB

- k) *AFNse* = -42 dB
- l) *NECD* = '1'
- m) *ASdt* = -18 dB

The register configuration which implements the above is:

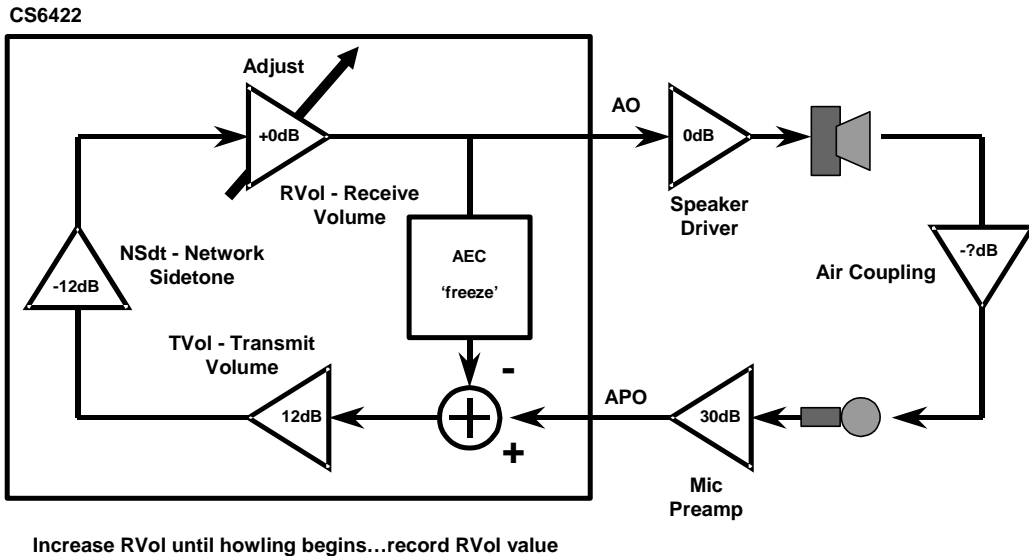
- reg 0: 5480 (d480 if internal mic preamp is used)
- reg 1: 0a82
- reg 2: 0804
- reg 3: 2006
- reg 4: 5008
- reg 5: 018a

- 3) Set *ACC* to 'Normal'.
- 4) Inject speech or 2.8 Vpp white noise into NI for 5 to 10 seconds. This trains the AEC to the acoustic path. See Figure 15.
- 5) Set *ACC* to 'Freeze'. Try to minimize the movement in the acoustic path from here on, as path changes will adversely affect the ERLE re-

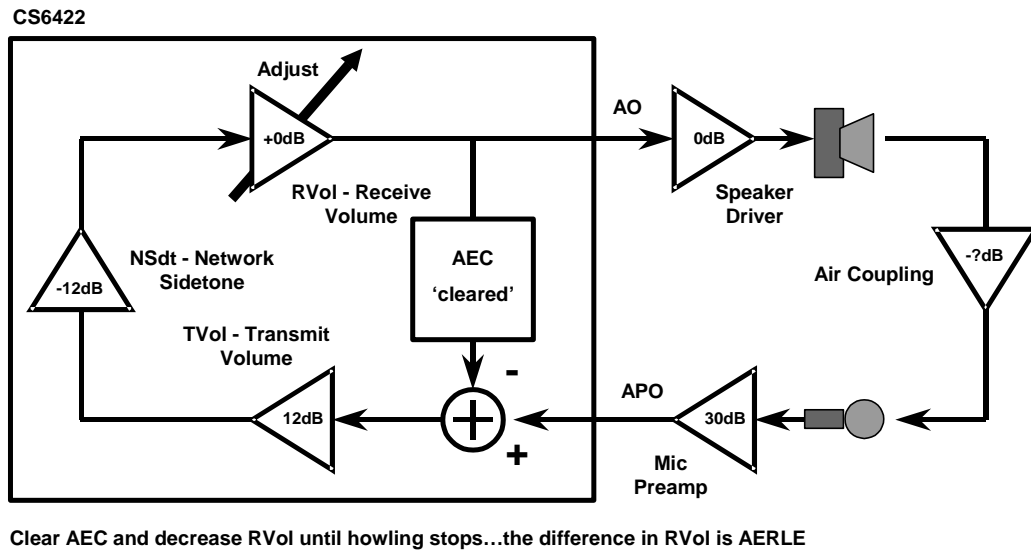


**Figure 15. Acoustic ERLE Measurement -- Train the AEC**

- sults.
- 6) Disconnect the signal source from NI (or simply turn it off).
  - 7) Close the loop by setting NSdt to '-12dB', RVol to '0 dB', and TVol to '+12 dB'.
  - 8) Increase (or decrease) RVol until the system just starts howling. Record this value.
  - 9) Set ACC to 'cleared'.
  - 10) Decrease RVol until the system just stops howling. Record this value.
  - 11) The worst-case ERLE is the difference between



**Figure 16. Acoustic ERLE Measurement -- Freeze AEC**



**Figure 17. Acoustic ERLE Measurement -- Clear AEC**

the two RVol values in dB.

### 1.5.4 Call Testing and Coefficient Optimization

The following tests are useful for optimizing the CS6422 register settings. These tests should be performed in a car, not a lab. They can be performed in a lab, but the resulting coefficients and settings will not be optimal for actual car use.

First, a note on safety. One of the compelling forces driving the use of hands-free kits in cars is added safety. Many governments have realized the dangers inherent when people drive and talk on the phone at the same time and have mandated the use of hands-free accessories when cell phones are used in cars. The studies do not mention the dangers involved in driving while fine-tuning hands-free system parameters.

Please, be careful.

Optimal car testing requires a minimum of three people: a driver, a passenger, and a far-end talker. The driver's responsibility is solely to drive the car and to avoid accidents. The passenger and the far-end talker perform the call testing and parameter optimization.

Once the test hardware is installed in the car, set the Acoustic Coupling to a value of -9 dB using the techniques discussed earlier in this note. Then begin testing.

#### 1.5.4.1 Far-end single-talk counting

The first test is the Far-End Single-Talk Counting test. In this test, the far-end talker speaks, usually incremental counting, and the near-end talker remains silent.

This test has several sub-tests which are used to configure specific parameters.

##### 1.5.4.1.1 Subtest A, EC Convergence Test

The EC Convergence Test allows the far-end listener to hear the echo canceler train, and retrain

on changes in path. In this test, the CS6422 is loaded with the starting register configuration set listed earlier in this note, which is repeated here for convenience:

Configure the CS6422 from reset with the following:

- 1) *Mic* set to '1' or '0', depending on whether the internal mic preamp is used or not
- 2) *GB* = 0.75 dB/ms
- 3) *RVol* = +18 dB (this is the default setting; RVol should be set between +6 dB and +30 dB)
- 4) *Taps* = 55.5 ms
- 5) *TVol* = 0 dB (this is the default setting; close to 0 dB is better; TVol should be between 0 dB and +12 dB)
- 6) *NseRmp* = 12 dB/s
- 7) *HDly* = 150 ms
- 8) *IdlTx* = enabled
- 9) *TSAAtt* = 24 dB
- 10) *PCSen* = low
- 11) *TSThd* = 12 dB
- 12) *TSBias* = 18 dB (default setting)
- 13) *AErle* = 18 dB
- 14) *AFNse* = -42 dB
- 15) *TGain* = 0 dB (can be 0 dB, +6 dB, +9.5 dB, or +12 dB, depending on mic preamp requirements)
- 16) *NECD* = '1' (should be '0' if a network sidetone is present)
- 17) *ASdt* = -18 dB

The register configuration which implements the above is:

reg 0: 1400 (9400 if internal mic preamp is used)

reg 1: 0a22

reg 2: 0a14

reg 3: a046

reg 4: 5008

reg 5: 018a

For the EC Convergence Test, we also disable Half-Duplex mode and the Transmit Suppressor by setting HDD = TSD = '1'.

Start the test by setting ACC to 'cleared' and then back to 'normal'. This resets the adaptive filter to a cleared state.

Initiate the call and have the far-end talker begin counting while listening for his or her echo. The level of the echo should lessen with each count until it reaches a point at which it will attenuate no further. The test is simply to find out if the echo level drops on successive counts or not. If it doesn't attenuate, then there's a problem in the system, usually caused by too much distortion in the path.

The test can be repeated by setting ACC to 'cleared' and then back to 'normal'.

#### 1.5.4.1.2 Subtest B, Half-Duplex to Full-Duplex transition time

Subtest B measures the time it takes for the CS6422 to train sufficiently to move from Half-Duplex mode to Full-Duplex mode.

The CS6422 is loaded with the standard recommended coefficient set. At the start of the test, ACC is set to 'cleared' then back to 'normal'. This resets the adaptive filter to its cleared state and prepares it to train to the acoustic path.

After ACC has been set to 'normal', the far-end talker begins counting and listening for echo. The number at which echo first appears indicates the transition time to full-duplex.

If it is difficult to determine when the echo appears, the transmit suppressor can be disengaged for this test by setting TSD to '1'. This removes the supplementary echo suppression.

#### 1.5.4.1.3 Subtest C, Transmit Suppression test

This test verifies that the TSThd parameter is set correctly, which controls the engagement of the Transmit Suppressor. If TSThd is set too high, the suppressor will not engage reliably, and the far-end listener will hear residual echo during single-talk.

In this test, the CS6422 is loaded with the standard coefficient set, with TSMde set to '1', Noise Guard disabled. The far-end talker counts until the device transitions to full-duplex. Once in full-duplex, the transmit suppressor is disengaged by setting TSD to '1'. The far-end talker resumes counting. If there is no noticeable reduction in the echo level, then the transmit suppressor is not engaging, and the TSThd value should be reduced.

#### 1.5.4.2 Double-talk

In the Double-talk test, both the far-end talker and the near-end talker speak simultaneously. In the Double-talk test, the CS6422 is loaded with the recommended set of coefficients. The AEC trains when the far-end talker speaks while the near-end talker remains silent. Once the far-end talker hears the system move to full-duplex, Double-talk testing can begin.

During the testing, we recommend that one end of the link count numbers while the other end names letters of the alphabet, days of the week, months of the year, or any other syllabic progression that is easy to generate and easy to detect dropped words.

The goals are to detect how "stable" the system is in full-duplex by seeing how long the double-talk can persist without the system dropping to half-duplex and to test the operation of the transmit suppressor.

The transmit suppressor should disengage when the near-end talker speaks. If it doesn't disengage properly, then the near-end talker's speech will be severely attenuated while the far-end is speaking. If this happens, adjust the TSBias control to a lower value (15 dB) and test again.

**1.5.4.3 Half-duplex alternate counting**

The Half-duplex alternate counting test tests the half-duplex behavior of the system. This test is useful even if half-duplex mode is disabled, because the half-duplex engine controls in part the training of the adaptive filters.

In the Half-duplex alternate counting test, the CS6422 is loaded with the recommended configuration set, with the exception that ACC is set to ‘cleared’, which prevents the echo canceler from training and keeps the system in half-duplex. HDD must be set to ‘0’ for this test.

In this test, the talkers alternate counting in sequence. For example, the far-end says, “one”, followed by the near-end saying, “two”, followed by the far-end saying “three”, etc.

Each side listens for the expected count, and looks for dropped counts. If the near-end environment is noisy, it may take a few seconds for the half-duplexor to begin switching properly.

Parameters that can be adjusted for this test are HDly, THDet, RHDet, and RSThd. HDly controls

the delay between the system switching from transmit mode to receive mode. RHDet and THDet control the SNR level at which speech is detected. Generally, RHDet and THDet should be equal; however, if one end of the link is consistently cut off, they may need to be imbalanced in order to improve performance.

If there is a network sidetone, it is important that the Network Echo Canceler be enabled during half-duplex testing, otherwise the transmit path may be cut off by its own network echo, causing halted speech.

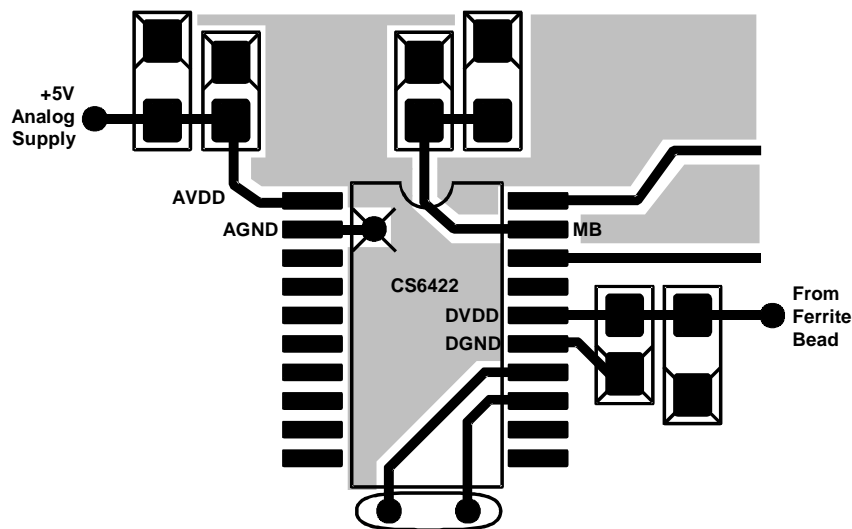
**1.6 Layout Guidelines**

This section contains guidelines regarding PCB layout in CS6422 systems and car kits in particular.

**1.6.1 CS6422-specific guidelines**

- 1) All ground pins on the CS6422 should be referenced to AGND (analog ground plane).

Signals should NOT be routed under the CS6422, with the exception of the crystal oscillator signals and the MB signal as shown in Fig. 18.



**Figure 18. Suggested CS6422 Layout**

- 2) Decoupling and loading capacitors should be placed as close as possible to the pins they decouple (AVDD, AGND, DVDD, DGND, MB, CLKI, CLKO), with the smaller-valued capacitor closest to the pin.
- 3) The traces between the MB pin and the decoupling capacitors connected to it should be short, shielded with ground plane, and located far from potentially interfering signals.

**1.6.2 Car-Kit guidelines**

Cellular car kits typically have three power networks: +12VBATT/BATTGND, +5VD/DGND, and +5VA/AGND.

Components powered from a particular power network should have ground connections to the ground associated with that power network. For example, the CS6422 should be powered from +5VA and its ground pins, including power supply decoupling capacitor grounds and signal grounds, should tie to AGND.

The one exception to this is that the attenuator resistor in the resistor divider between AO and the speaker driver should be tied to the ground of the

speaker driver, typically BATTGND if the speaker driver is powered from the +12V battery source. This prevents the speaker driver from amplifying noise caused by potential differences between AGND and BATT GND.

Following are listed the power networks and components associated with each network.

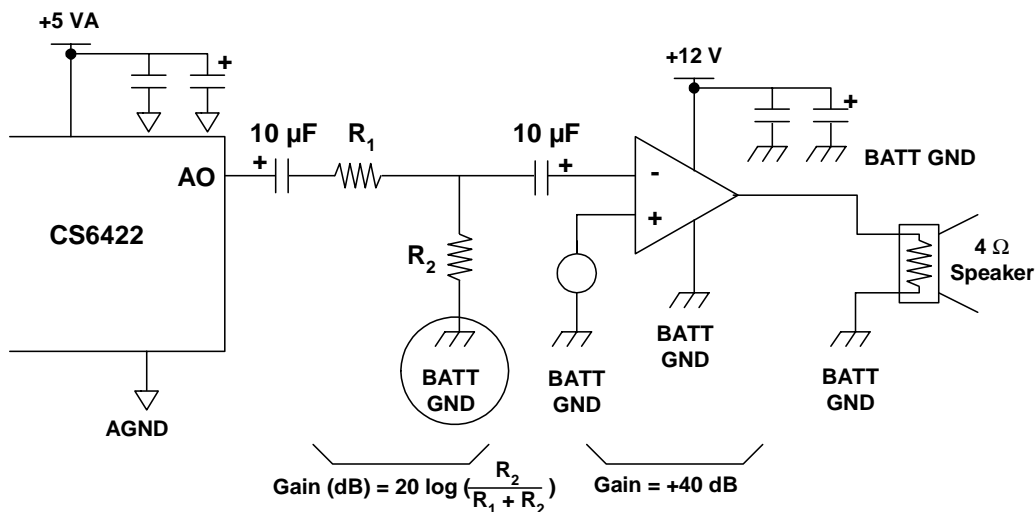
**1.6.2.1 +5VA/AGND Components**

- 1) CS6422, AVDD, DVDD, AGND, DGND, decoupling capacitors, crystal loading capacitors, signal R's and C's with the exception of the attenuator resistor in the voltage divider between AO and the speaker driver input.
- 2) Op-amps and analog circuitry between the cell phone and the CS6422's NO and NI pins.

**1.6.2.2 +5VD/DGND Components**

- 1) Microcontroller
- 2) Additional +5V control logic circuitry

Note: If the CS6422 and the microcontroller are powered from the same +5V regulator, +5VA should be derived from the regulator output (+5VD) through a ferrite bead.



**Figure 19. Speaker Driver Implementation**

**1.6.2.3 +12VBATT/BATTGND Components**

- 1) Cell-phone battery charger circuitry
- 2) Speaker driver (if powered from +12V source)

Most cellular phones provide two grounds at the hands-free connector, DGND and AGND. DGND ties to the phone battery, and should be connected to BATTGND on the hands-free kit. The cell phone’s analog interface pins are referenced to the AGND signal, and this AGND should tie to AGND on the hands-free kit.

The DGND plane on the hands-free kit should be connected to AGND plane in exactly one place.

**1.7 Quick list of important points:**

The following is a list of things to verify in the system.

**1.7.1 Reset and configuration timing**

It is vital that the CS6422 receive a cold reset after power-on.

- 1) The  $\overline{RST}$  low time should be at least 1  $\mu$ s.
- 2) The time between  $\overline{RST}$  rising and  $\overline{DRDY}$  falling should be at least 110 ms. This is commonly overlooked.
- 3) Furthermore, when writing multiple control

words to the CS6422, the words themselves cannot be written at a rate faster than one every 125  $\mu$ s, since this is the rate at which they are polled by the DSP. That is, the time from  $\overline{DRDY}$  falling to  $\overline{DRDY}$  falling must be at least 125  $\mu$ s.

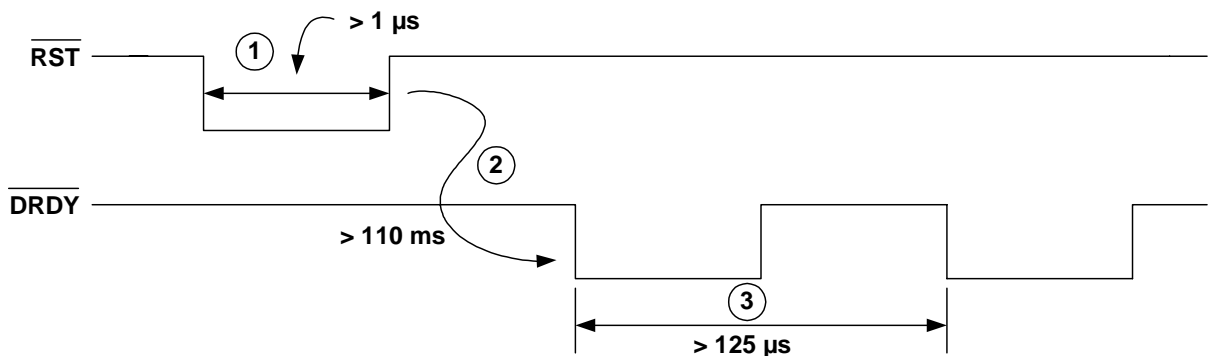
In implementation, it is easiest to ensure this timing by limiting the STROBE frequency. Setting the STROBE period to 10  $\mu$ s, for example, makes the total time for a register write 200  $\mu$ s (16 data bits + 4 extra STROBE pulses = 20 cycles; 20 cycles \* 10  $\mu$ s = 200  $\mu$ s).

**1.7.2 Distortion**

The total distortion present in any signal path that the echo cancelers are trying to model should be limited to 2% THD, worst case across the frequency band of interest.

**1.7.3 Speaker/mic placement**

The system should be tested in a car, not a lab. The microphone should be placed near the driver’s visor or rear-view mirror. The speaker should be placed on top of the dash, or in some location such that there is a minimum of movement in the air space between the speaker and the microphone.



**Figure 20. CS6422 Reset and Configuration Timing**

### ***1.7.4 Acoustic coupling***

The maximum acoustic coupling (across frequency) between the speaker and the microphone should be limited to -9 dB. This can be tested and verified by using techniques described earlier.

### ***1.7.5 Training sequence***

The Acoustic Echo Canceler trains only when the far-end is talking while the near-end is silent. When

the system is in half-duplex mode, the AEC trains whenever the receive path is active. When the system is in full-duplex mode, the AEC does not train during double-talk. It is only when the near-end is silent while the far-end is talking that the acoustic adaptive filter trains.

The Network Echo Canceler trains only when the near-end is talking and the far-end is silent. When the system is in half-duplex mode, the NEC trains when the transmit path is active.

## 2. APPENDIX - EXAMPLE SPEAKER DRIVER CIRCUITS

In the following pages are 5 example speaker driver circuits. In each case, the maximum gain is listed that the speaker driver can assume for the associated power supply voltage and a 4 ohm speaker. If less gain is needed, R1 can be increased or R2 can be decreased. As discussed previously, volume control should be implemented using the RVol control inside the CS6422. DO NOT allow the gain of the speaker driver to be changed during a call.

In each of the circuits, simple bandpass filtering is implemented by using a single-pole high-pass corner around 300 Hz and a single-pole low-pass corner around 4 kHz. In systems that use a high-quality speaker whose frequency response is flat above 15 kHz, additional low-pass filtering may be necessary to reduce the level of D/A noise from the CS6422.

In these systems, a 3-pole Butterworth filter can be placed before the speaker driver. An example 3-pole Butterworth filter is shown in Figure 21.

In this filter, the attenuation can be selected by adjusting the ratio of R2/R1, preferably by reducing R2.

$$Gain = \frac{R2}{R1}$$

$$C2 = \frac{1}{2\pi(R2)(4kHz)}$$

### 2.1 Example 1: TDA1519A -- 15 Watts into 4 Ω

The schematic for the TDA1519A speaker driver is shown in Figure 22. The TDA1519A, from Philips Semiconductors, is capable of supplying 15 Watts of RMS power into a 4 Ω load with less than 2% THD. The gain required to achieve 15 Watts is +17.8 dB, which is implemented with an attenuation stage of -28.2 dB followed by the

TDA1519A's inherent +46 dB of gain.

$$Gain = 200 \times \frac{R2}{R1 + R2}$$

The high-pass corner frequency near 300 Hz is given by:

$$F_{hp} \approx \frac{1}{2\pi C1(R1 + R2)}$$

The low-pass corner frequency near 4 kHz is given by:

$$F_{lp} \approx \frac{1}{2\pi C2(R1 \parallel R2)}$$

### 2.2 Example 2: TDA2003 -- 3 Watts into 4 Ω

The schematic for the TDA2003 speaker driver is shown in Figure 23. The TDA2003, from ST, is capable of supplying 3 Watts of RMS power into a 4 Ω load with less than 2% THD. The gain required to achieve 3 Watts is +10.7 dB, which is implemented with an attenuation stage of -29.3 dB followed by the TDA2003 gain implemented as +40 dB.

$$Gain = \left( \frac{R2}{R1 + R2} \right) \times \left( 1 + \frac{R4}{R5} \right)$$

The high-pass corner frequency near 300 Hz is given by:

$$F_{hp} \approx \frac{1}{2\pi C1(R1 + R2)}$$

The low-pass corner frequency near 4 kHz is given by:

$$F_{lp} \approx \frac{1}{2\pi C2(R1 \parallel R2)}$$

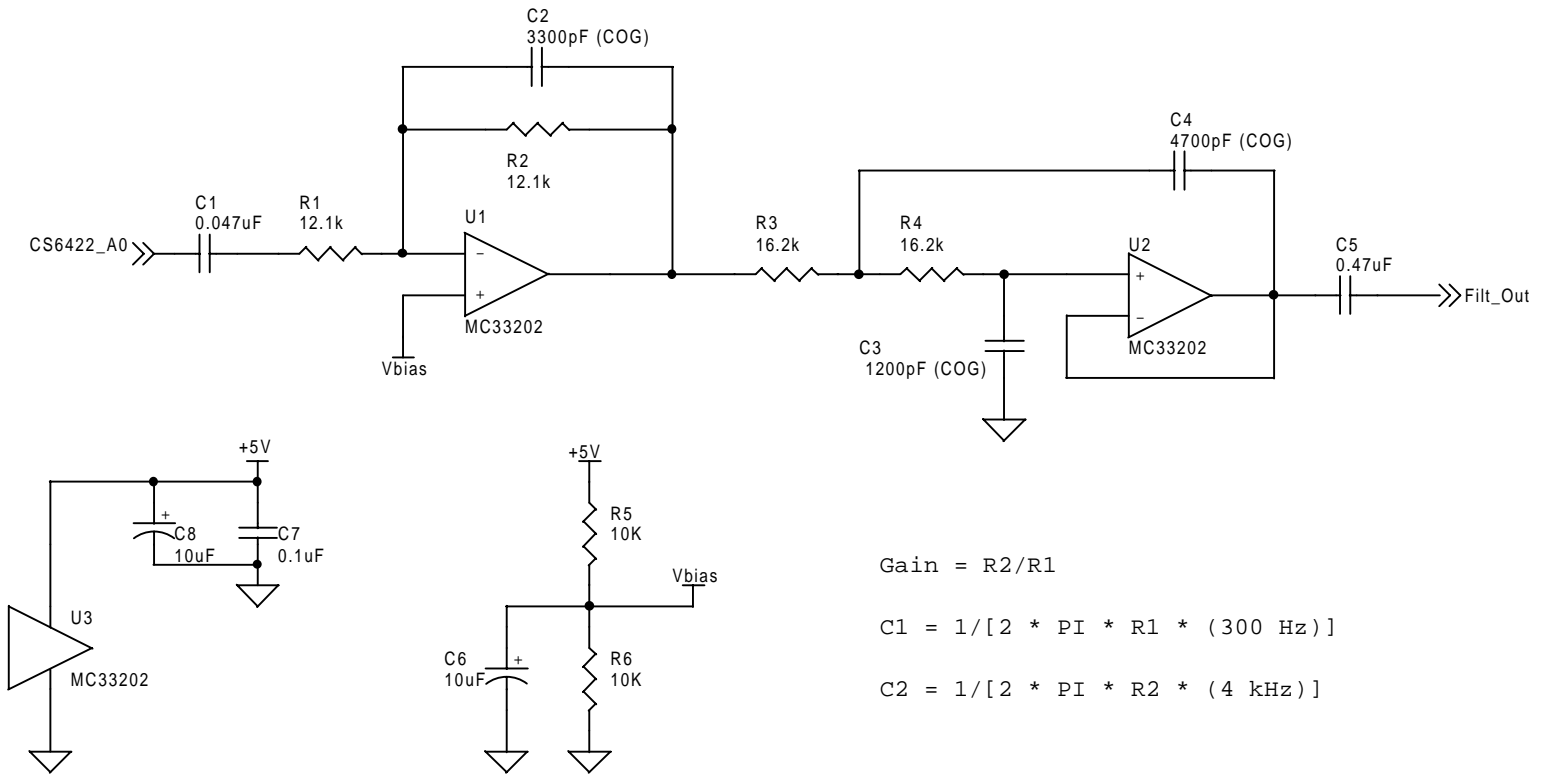


Figure 21. Example 4 kHz, 3-Pole Butterworth Low-Pass Filter

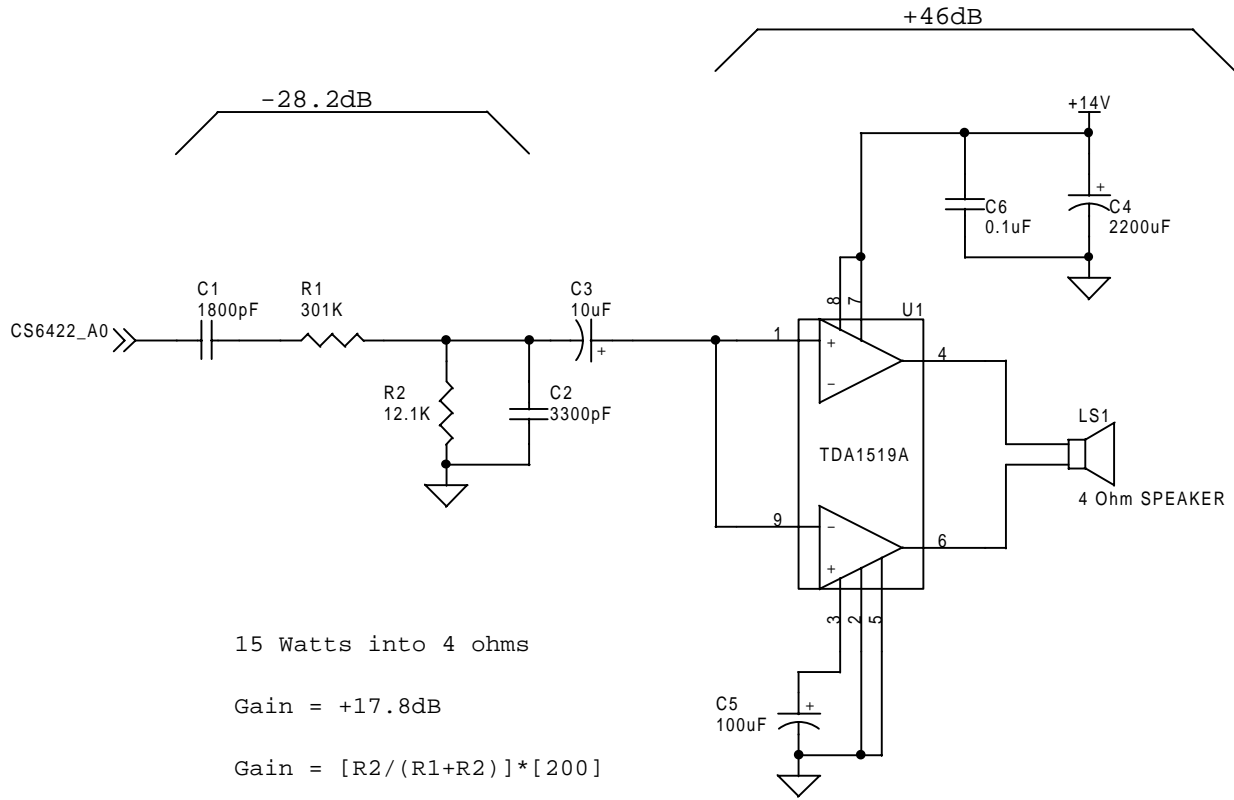


Figure 22. TDA 1519A Schematic

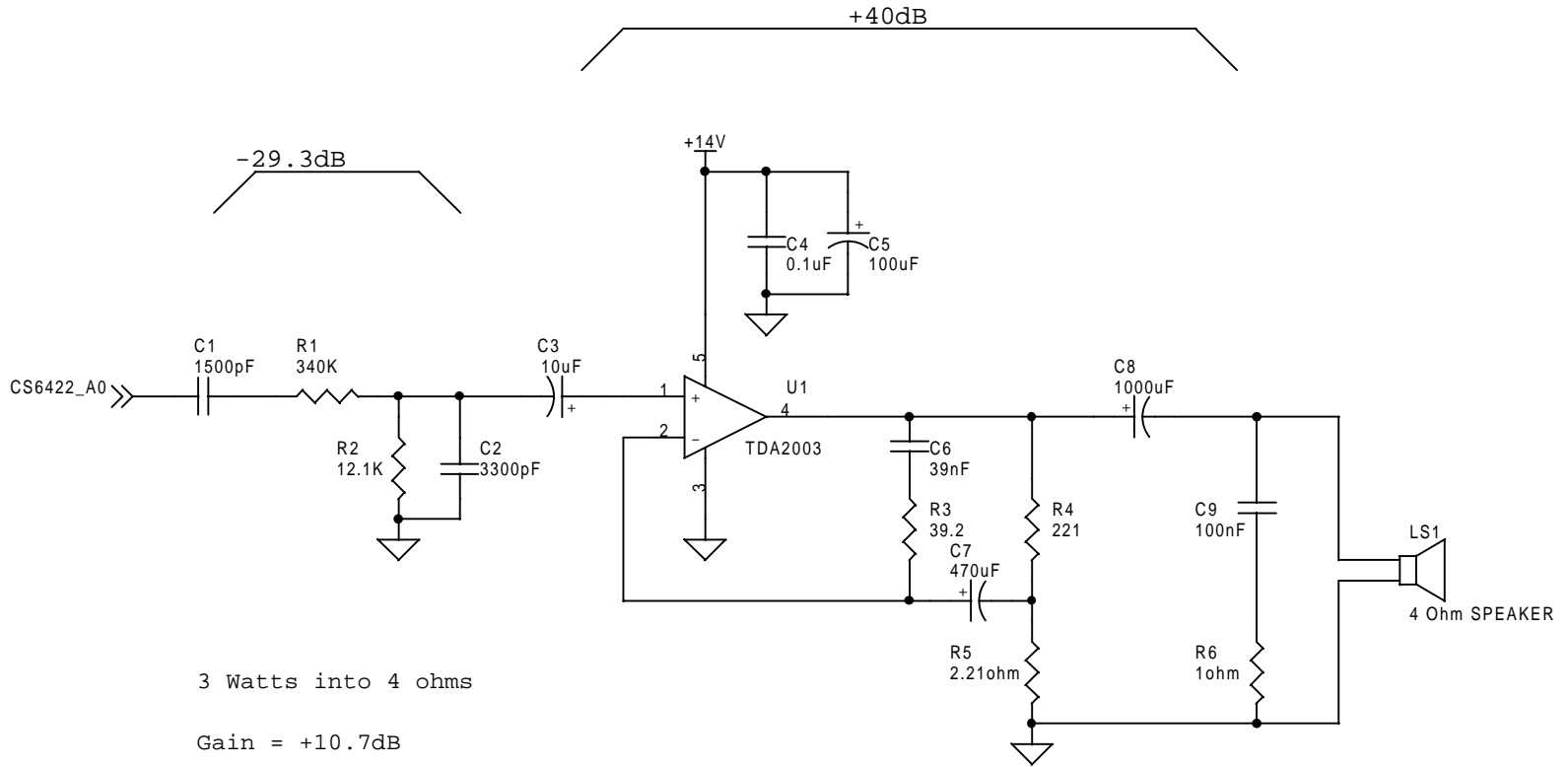


Figure 23. TDA 2003 Schematic



**2.3 Example 3: TDA1905 -- 2.5 Watts into 4 Ω**

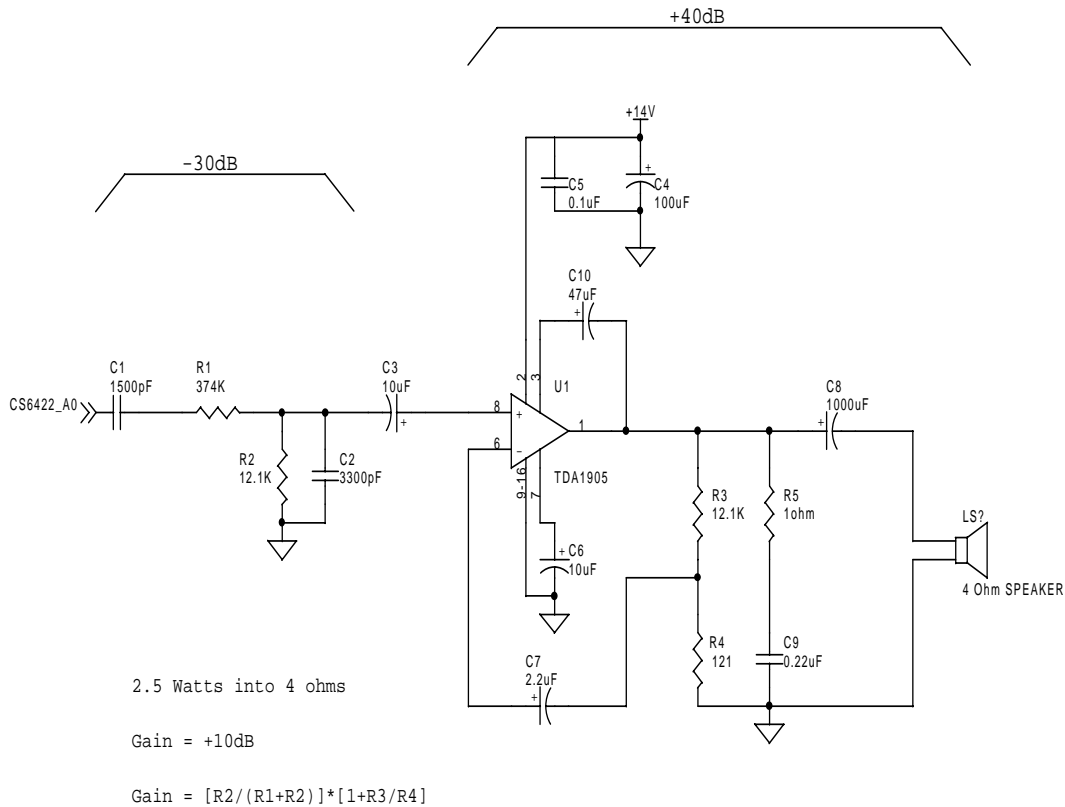
The schematic for the TDA1905 speaker driver is shown in Figure 24. The TDA1905, from ST, is capable of supplying 2.5 Watts of RMS power into a 4 Ω load with less than 2% THD. The gain required to achieve 2.5 Watts is +10 dB, which is implemented with an attenuation stage of -30 dB followed by the TDA1905 gain implemented as +40 dB.

$$Gain = \left( \frac{R2}{R1 + R2} \right) \times \left( 1 + \frac{R3}{R4} \right)$$

The high-pass corner frequency near 300 Hz is given by:

$$F_{hp} \approx \frac{1}{2\pi C1(R1 + R2)}$$

The low-pass corner frequency near 4 kHz is given by:



**Figure 24. TDA 1905 Schematic**

**2.4 Example 4: LM1877-- 2 Watts into 4 Ω**

The schematic for the LM1877 speaker driver is shown in Figure 25. The LM1877, from National Semiconductor, is capable of supplying 2 Watts of RMS power into a 4 Ω load with less than 2% THD. The gain required to achieve 2 Watts is +9 dB, which is implemented with an attenuation stage of -17 dB followed by the LM1877 gain implemented as +26 dB.

$$Gain = \left( \frac{R2}{R1 + R2} \right) \times \left( 1 + \frac{R3}{R5} + \frac{R6}{R5} \right)$$

The high-pass corner frequency near 300 Hz is given by:

$$F_{hp} \approx \frac{1}{2\pi C1(R1 + R2)}$$

The low-pass corner frequencies near 4 kHz are given by:

$$F_{lp} \approx \frac{1}{2\pi C2(R1 \parallel R2)}$$

**2.5 Example 5: LM4861-- 1 Watt into 4 Ω**

The schematic for the LM4861 speaker driver is shown in Figure 26. Note that the power supply for this speaker driver is +5V. The LM4861, from National Semiconductor, is capable of supplying 1 Watt of RMS power into a 4 Ω load with less than 2% THD. The gain required to achieve 1 Watt is +6 dB.

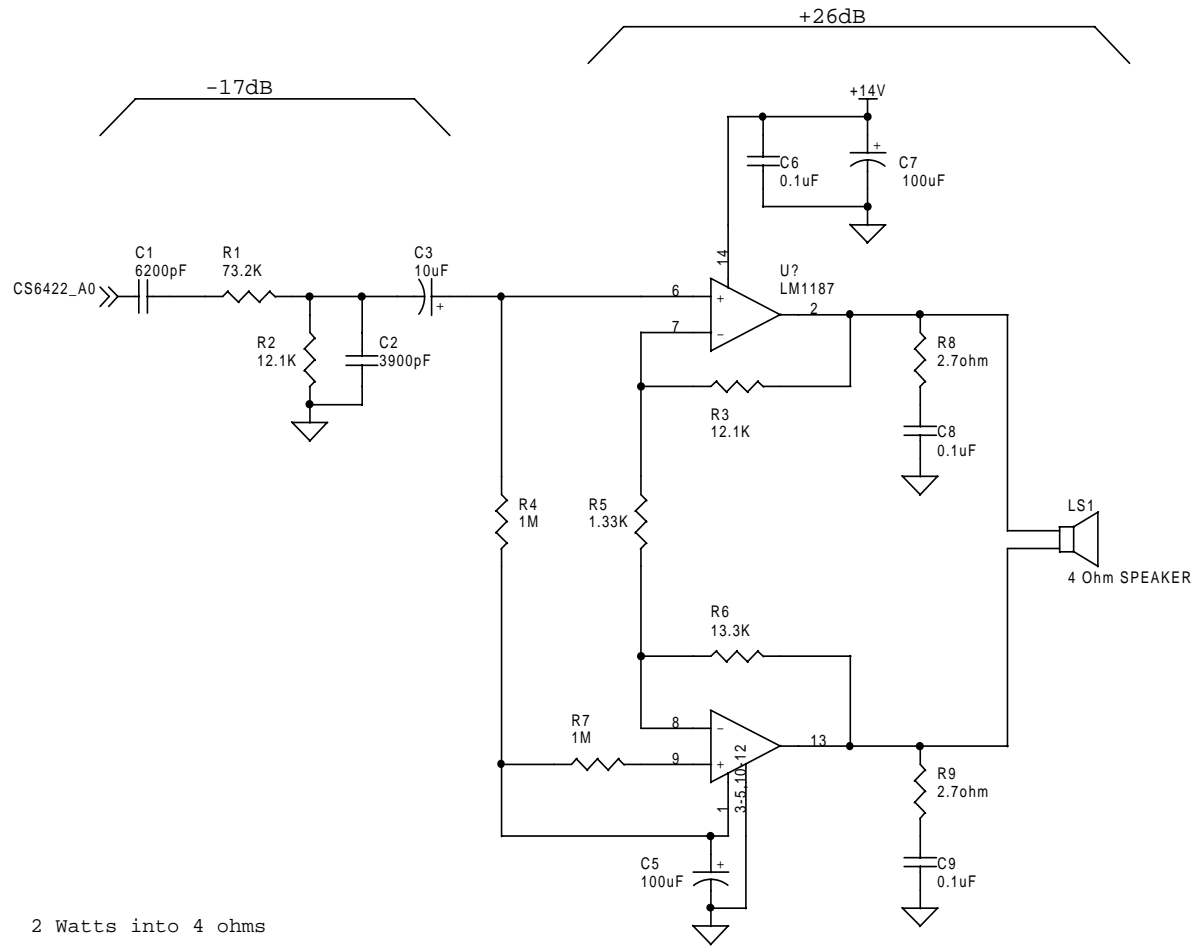
$$Gain = 2 \times \left( \frac{R2}{R1} \right)$$

The high-pass corner frequency near 300 Hz is given by:

$$F_{hp} = \frac{1}{2\pi(C1)(R1)}$$

The low-pass corner frequency near 4 kHz is given by:

$$F_{lp} = \frac{1}{2\pi(C2)(R2)}$$

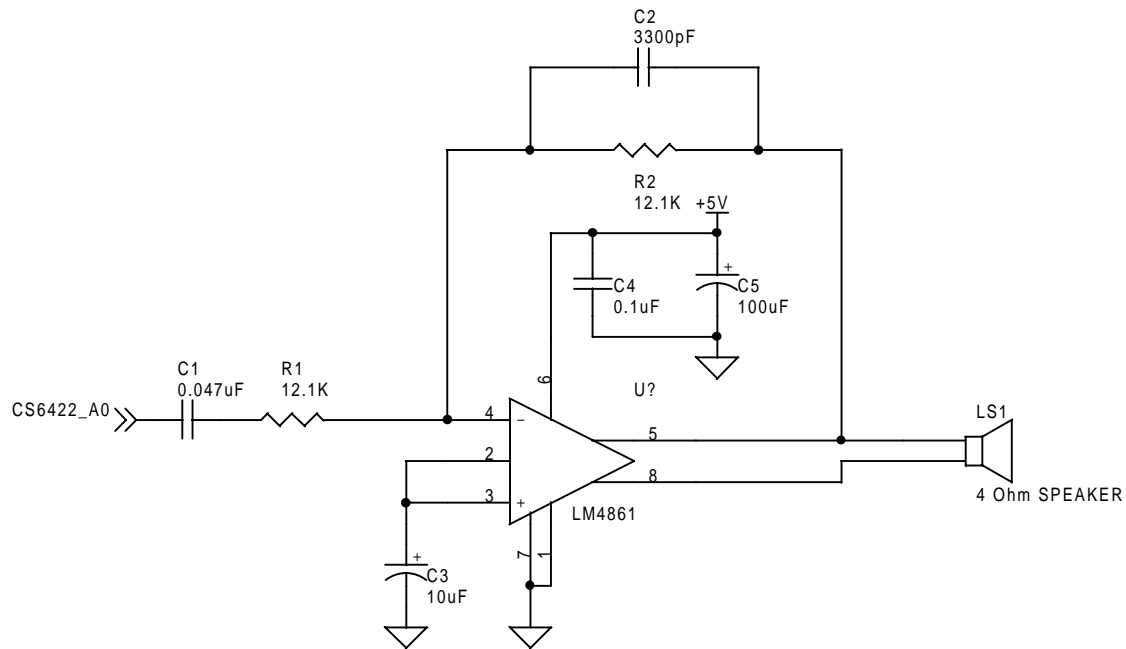


2 Watts into 4 ohms

Gain = +9dB

$$\text{Gain} = [R2 / (R1 + R2)] * [1 + R3 / R5 + R6 / R5]$$

Figure 25. LM 1877 Schematic



1 Watt into 4 ohms

Gain = +6dB

Gain =  $(2) * (R2/R1)$

Figure 26. LM 4861 Schematic

• **Notes** •

SMART  
Analog™



LittleDiode supplies new, hard to find or obsolete electronic components and semiconductors all over the world.

With over two million different components listed you are sure to find the part you need.

Feel free to visit us today at our online store:

[LittleDiode.com](http://LittleDiode.com)

Looking forward to providing you with the best possible service.