

Appendix G to Application Note 163

CRYSTAL DIGITAL POST-PROCESSING USER'S GUIDE FOR THE CS49330

Contents

- Crystal Digital Post-Processing (D.P.P.) Description
- Hardware Configurations Supported by the CS49330 and the Crystal D.P.P. Code
- How to Control Application Modules such as:
 - Audio Manger for Crystal D.P.P.
 - Crystal D.P.P. Manager
 - Tone Control/3-Band Parametric EQ Manager
 - Dual-Precision Bass Manager

Description

This document includes a brief description of hardware configuration and in depth descriptions of application control modules. The main body of this document covers all the features included in the D.P.P. application.

- Crystal D.P.P. Specific Features:
 - Multichannel and Stereo PCM Inputs
 - Full Bandwidth Channel (L,C,R,Ls,Rs) 3-Band Parametric Equalization
 - Full Bandwidth Channel (L,C,R,Ls,Rs) Tone Control
 - LR2LsRs Copy Module
 - Impulse/Noise Generator Module
 - Dual-Precision Bass Management
 - Dolby Downmix Module
 - Dual Zone Output
 - Stereo PCM + Multichannel Source Mixer

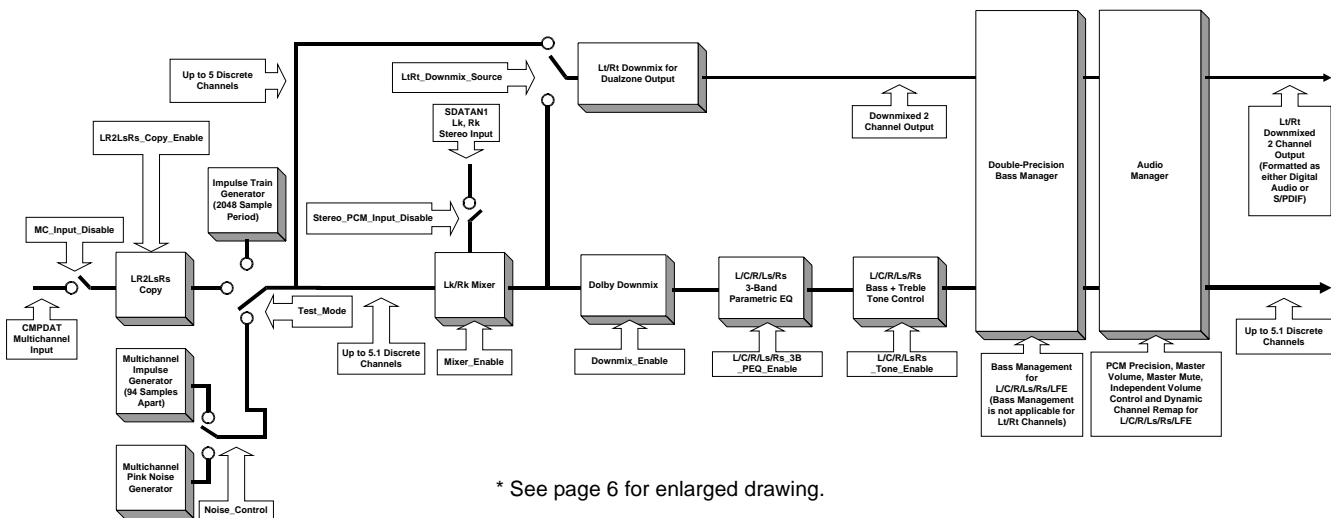

TABLE OF CONTENTS

1. OVERVIEW 4
1.1 Crystal D.P.P. Multichannel PCM Post-Processing Application Description 4
1.2 Crystal D.P.P. and Multichannel Audio Processing Module Terminology 4
2. HARDWARE CONFIGURATION 7
3. APPLICATION MODULES 12

Contacting Cirrus Logic Support

For a complete listing of Direct Sales, Distributor, and Sales Representative contacts, visit the Cirrus Logic web site at: http://www.cirrus.com/corporate/contacts/

Dolby Digital, AC-3, Dolby Pro Logic and Dolby Surround are trademarks and the "Dolby Digital Logo", "Dolby" and the double-"D" symbol are registered trademarks of Dolby Laboratories Licensing Corporation.

Preliminary product information describes products which are in production, but for which full characterization data is not yet available. Advance product information describes products which are in development and subject to development changes.

LIST OF FIGURES

Figure 1. Crystal D.P.P. Block Diagram	6
Figure 2. Filter Topology of Dual-Precision Bass Manager	26
Figure 3. Bass Manager Processing Unit	27
Figure 4. Subwoofer Summing Module	27

LIST OF TABLES

Table 1. Input/Output Configurations Supported By: Crystal D.P.P. Code	7
Table 2. Professional Channel Status bytes 0, 1 and 3	8
Table 3. Consumer Channel Status Bytes 0, 1 and 3	9
Table 4. Unsolicited Messages	11
Table 5. Audio Manager for Crystal D.P.P.	13
Table 6. Crystal D.P.P. Manager	16
Table 7. Dual-Precision Bass Manager	21
Table 8. Tone Control + 3-Band Parametric EQ Manager	28
Table 9. Shelf Gain Values for Tone Control	35

1. OVERVIEW

This software user's guide covers the multichannel PCM Crystal Digital Post-Processing (D.P.P.) application code. This code is designed to run exclusively on the CS49330, which in a Dual-DSP system would act as the digital post-processor to a CS49325, CS49326, CS49328 or the CS49329 that produces up to 5.1 discrete channels of PCM from such decoding algorithms as: AC-3[™], DTS[®], MPEG Multichannel, Crystal Original Surround and MPEG-2 AAC. There is no license requirement for using the Crystal D.P.P. code or the IC that this code runs on, other than a Dolby Pro Logic[™] license from Dolby Laboratories. However, most systems that would use this code should already have a Dolby Digital license for the primary decoder.

This document contains only the Crystal D.P.P. audio IC application code-specific information, such as: Audio Manager for Crystal D.P.P., Crystal D.P.P. Manager, Tone Control and 3-Band Parametric Equalization Manager. For a description of hardware configuration and in-depth descriptions of application messaging protocol, application control modules and application configuration examples other than those pertaining to the Crystal D.P.P. specific features, please refer to AN163.

1.1 Crystal D.P.P. Multichannel PCM Post-Processing Application Description

Figure 1 is a block diagram of the Crystal D.P.P. multichannel PCM post-processing application. The diagram gives an idea of the processing sequence of the various modules in the Crystal D.P.P. application code (DPP_3XXX.LD).

The primary goal of the Crystal D.P.P. multichannel PCM post-processing application code is to off-load typical back-end processing performed on multichannel PCM output from a front-end audio decoder.

The main processing blocks in the Crystal D.P.P. 5.1 channel PCM post-processing application code are: LR2LsRsCopy, Pink Noise/Impulse Generator, Lt/Rt Downmix, Full Bandwidth Channel (L,C,R,Ls,Rs) 3-Band Parametric Equalization, Full Bandwidth Channel (L,C,R,Ls,Rs) Tone Control, Double-Precision Bass Management and Audio Manager (which offers: Independent and Master Volume Control, Independent Channel Muting, Independent Channel Delay, and Channel Remap).

The Lk/Rk Mixer module provides an option for an additional stereo PCM input which may be mixed into the multichannel PCM. Depending on the design, it may be desirable to output a 2 channel (Lt,Rt) downmix of the multichannel PCM input prior to post-processing. This is facilitated by the Lt/Rt Downmix module which outputs the 2 channel downmix via the XMT (S/PDIF) port of the CS49330. Other processing features include a L and R channel to Ls and Rs channel copy module and a test module which is capable of generating noise and impulse signals on selected channels of the multichannel PCM input overriding the multichannel input to the CS49330.

1.2 Crystal D.P.P. and Multichannel Audio Processing Module Terminology

1.2.1 Multichannel PCM Input

Although this is really not a PCM processing function, it is nevertheless worth description. This block is responsible for capture and generation of the multichannel PCM input from the port configured for multichannel PCM input to the CS49330. Note that it is possible to disable this function (see Figure 1) in which case the multichannel PCM input is undefined. It is up to the user to configure the *Mixer* appropriately (i.e. - zero-out multichannel input) to ensure predictable output in this circumstance.

1.2.2 LR2LsRs Copy

This block, if enabled (please refer to Section 3.2 “Crystal D.P.P. Manager”), replaces the Ls and Rs channel data with those from the L and R channels, respectively.

Pink Noise Generator, 94 Sample Impulse Generator, and 2048 Sample Impulse Train Generator

If the test mode function is set to 10 (please refer to Section 3.2 “Crystal D.P.P. Manager”), the input multichannel PCM is replaced by either “Pink Noise” or the “94 Sample Impulse Generator”, on a selected channel. If the test mode function is set to 01 (please refer to Section 3.2 “Crystal D.P.P. Manager”), the input multichannel PCM is replaced by “2048 Sample Impulse Train Generator”.

Pink Noise refers to the “pink” spectrum, having equal energy for equal logarithmic units of frequency, and with a Gaussian distribution of instantaneous amplitude. It has a bandwidth from 500 Hz to 2 KHz to the -3 dB points, with slopes of 18 dB/octave below 500 Hz and above 2 KHz for all but the LFE channel. The LFE channel noise is band-limited by a LPF with a -6 dB response up to 80 Hz and a 24 dB/octave slope. The levels for L, C, R and LFE channels are -30 dBFS while the levels for Ls,Rs,Lsb,Rsb channels are -27 dBFS. Please refer to both Section 3.1 “Audio Manager for Crystal D.P.P.” and Section 3.2 “Crystal D.P.P. Manager” for how to enable this feature.

Alternatively the host may select one of two styles of Impulse Generation (either a Discrete Channel 94-Sample Impulse or a Synchronous All-Channel 2048 Sample Impulse Train). Please refer to both Section 3.1 “Audio Manager for Crystal D.P.P.” and Section 1 “Crystal D.P.P. Block Diagram” for how to enable either of these features.

1.2.3 Mixer

This processing block, if enabled, allows the optional stereo PCM input to be flexibly mixed into

any and all of the 6 channels of multichannel PCM input. Please refer to Section 3.2 “Crystal D.P.P. Manager” for how to enable this feature. It is up to the user to ensure that the mixing of PCM does not overflow.

1.2.4 Dolby Downmix

This processing block, if enabled, performs all the multichannel downmix modes prescribed by Dolby for 5.1 channel downmix. Please refer to Section 3.2 “Crystal D.P.P. Manager” for how to enable this feature.

1.2.5 Tone Control and 3-Band Parametric Equalization

Each full bandwidth channel (L,C,R,Ls,Rs) is provided with independent tone control and a 3-band parametric equalizer with separately controllable pre-attenuation, post-gain and downloadable biquad coefficients for each band. Please refer to Section 3.4 “Tone Control and 3-Band Parametric Equalization Manger” for how to enable and control these processing features.

1.2.6 Dual-Precision Bass Manager

A highly flexible and general bass management module is provided that enables the user to cover all standard bass management functions in the context of multichannel input and output configurations (please refer to Section 3.3 “Dual-Precision Bass Manager”).

1.2.7 Delay

Each of the 6 output channels may be independently delayed from -5 ms to 20 ms (please refer to Section 3.1 “Audio Manager for Crystal D.P.P.”).

Figure 1, located on the following page, is an enlarged version of the Crystal D.P.P. Block Diagram found on the cover page.

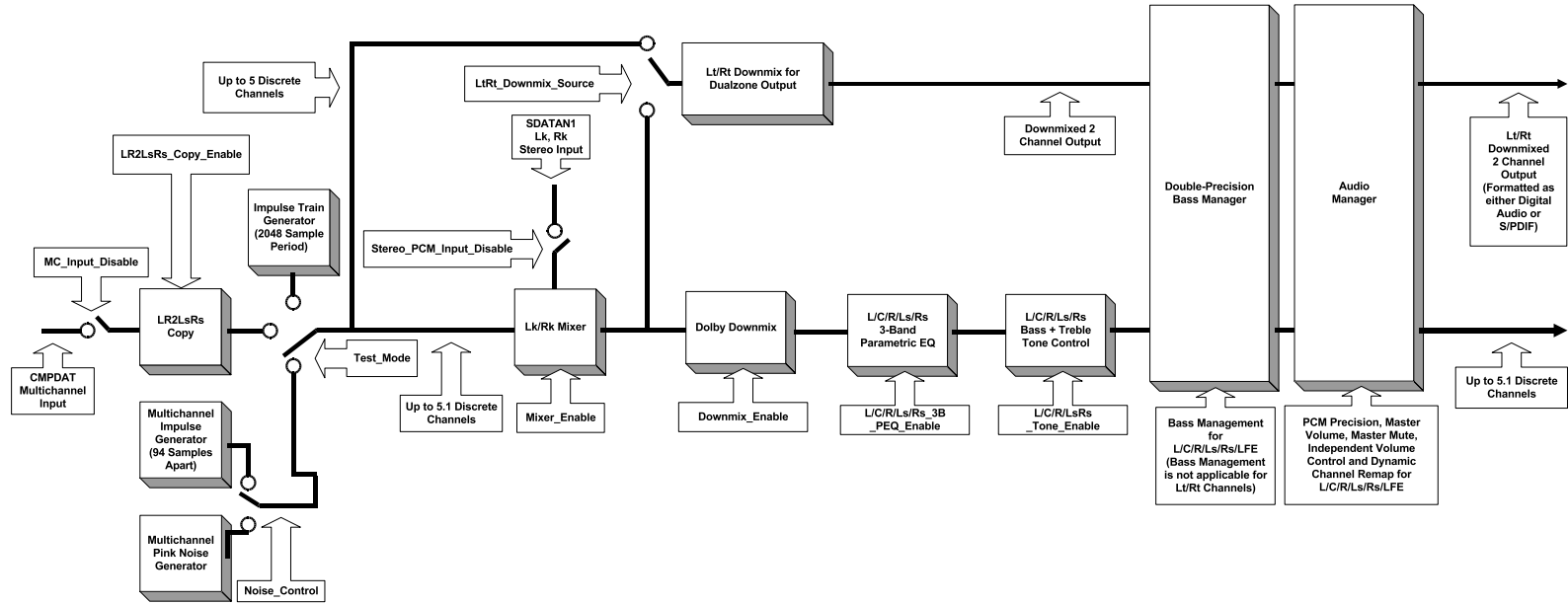

Figure 1. Crystal D.P.P. Block Diagram



2. HARDWARE CONFIGURATION

After download, and before kickstarting the application (please see Section 2.2 “Application Messaging” for more information on kickstarting), the host has the option of changing the default hardware configuration. Address checking for serial communication and data type and format for digital data input and output can be changed through hardware configuration settings. The entire hardware configuration can only be changed immediately after download.

2.1 Supported Input/Output Modes

The CS49330 has two input ports and two output ports (of the two output ports, one is configurable to act as either a S/PDIF or I²S output). The CS49300 Family datasheet describes the digital audio formats supported by the ports and gives a description of the ports themselves. The capabilities of each port are presented in the CS49300 Family datasheet although all configurations are not supported by all softwares. Each Application Code User’s Guide (AN161-AN163) specifies the exact input/output modes supported by the application.

For Crystal D.P.P. multichannel PCM-Processing code, in order to transfer of all 5.1 channels of PCM out of the CS4932X which initially decoded the AC-3, DTS, MPEG Multichannel, etc. data stream, multichannel mode is recommended. Please refer to the CS49300 Family Datasheet for more information on these hardware I/O configurations.

The following input/output modes are supported when the Crystal D.P.P. code is active:

IMPORTANT: Regardless of how the CS49330 is configured for operation while running the Crystal D.P.P. Multichannel PCM post-processing application code, it is assumed that there is a clock

on the port being fed Multichannel input even if the Multichannel PCM input is to be ignored (please refer to Section 3.2 “Crystal D.P.P. Manager” on how to configure the software to ignore Multichannel PCM input) in addition to valid clocks on the output.

I/O Configuration	Description	Supported Modes
INPUTA	Input Data Type	4,5
INPUTB	Input Data Format	2,3,7..9
INPUTC	Input SCLK/Data Edge	0, 1
OUTPUTA	Output Master/Slave Clock Setup	0,1
OUTPUTB	Output Data Format	0..7
OUTPUTC	Output MCLK Rate	0..3
OUTPUTD	Output SCLK Rate	0..3
OUTPUTE	Output SCLK/Data Edge	0..1

Table 1. Input/Output Configurations Supported By: Crystal D.P.P. Code

2.1.1 Configuring the XMT958/AUDAT3 Data Format

The following commands must be sent to configure the data present on the XMT958/AUDAT3 pin to S/PDIF format that is driven from the supplied MCLK that is 256 Fs:

```
0x800271
0xf7fff
0x800171
0x021000
```

The following commands must be sent to configure the data present on the XMT958/AUDAT3 pin to S/PDIF format that is driven from the supplied MCLK that is 512 Fs:

```
0x800271
0xf7fff
0x800171
0x061000
```

The following commands must be sent to configure the data present on the XMT958/AUDAT3 pin to I2S format that is driven from the supplied MCLK that is 256 Fs (set by default in D.P.P.):

```
0x800171
0x0a1000
```

The following commands must be sent to configure the data present on the XMT958/AUDAT3 pin to I2S format that is driven from the supplied MCLK that is 512 Fs:

```
0x800171
0x0e1000
```

One of the above configurations must be sent before kickstart.

2.1.2 S/PDIF (AES/EBU) Channel Status Block Control

The CS49330 offers the “minimum” professional implementation of control over the IEC60958 channel status bits. According to the IEC60958 specification, this means that the host has control over the setting of the “PRO” bit in the channel status word (Channel Status Byte 0, Bit 0).

“Professional use of the channel status block” will be implemented if the host sets the PRO bit to a state of logic 1. The additional following channel status bits may also be set by the host: Channel Status Byte 0, Bits 1-5; Channel Status Byte 1, Bits 0-7; and Channel Status Byte 3, Bits 0 and 1. Please refer to Table 2 for the IEC60958 definition for the setting of each bit or set of bits.

BYTE 0	
bit 0	PRO = 1
0	Consumer use of channel status block
1	Professional use of channel status block
bit 1	Audio
0	Normal Audio
1	Non-Audio
bits 2 3 4	Encoded audio signal emphasis
0 0 0	Emphasis not indicated. Receiver defaults to no emphasis with manual override enabled
1 0 0	None. Rec. manual override disabled
1 1 0	50/15 μS. Rec. manual override disabled
1 1 1	CCITT J.17. Rec. man. override disabled
X X X	All other states of bits 2-4 are reserved
bit 5	Lock: Source Sample Frequency
0	Locked - default
1	Unlocked
bits 6 7	Fs: Sample Frequency
0 0	Not indicated. Receiver default to 48 kHz and manual override or auto set enabled
0 1	48 kHz. Man. override or auto disabled
1 0	44.1 kHz. Man. override or auto disabled
1 1	32 kHz. Man. override or auto disabled

BYTE 1			
bits 0 1 2 3	Channel Mode		
0 0 0 0	Mode not indicated. Receiver default to 2-channel mode. Manual override enabled		
0 0 0 1	Two-channels. Man. override disabled		
0 0 1 0	Single channel. Man. override disabled		
0 0 1 1	Primary/Secondary (Ch. A is primary) Manual override disabled		
0 1 0 0	Stereophonic. (Ch. A is left) Manual override disabled.		
0 1 0 1	Reserved for user defined application		
0 1 1 0	Reserved for user defined application		
1 1 1 1	Vector to byte 3. Reserved		
X X X X	All other states of bits 0-3 are reserved.		
bits 4 5 6 7	User bits management		
0 0 0 0	Default, no user info indicated		
0 0 0 1	192 bit block structure Preamble 'Z' starts block		
0 0 1 0	Reserved		
0 0 1 1	User defined application		
X X X X	All other states of bits 4-7 are reserved.		

BYTE 3	
bits 0-7	Vectored target byte
XXXXXX	Reserved

Table 2. Professional Channel Status bytes 0, 1 and 3

BYTE 0	
bit 0	PRO = 0 (consumer)
0	Consumer use of channel status block
1	Professional use of channel status block
bit 1	Audio
0	Digital Audio
1	Non-Audio
bits 2	Copy / Copyright
0	Copy inhibited / copyright asserted
1	Copy permitted / copyright not asserted
bits 3 4 5	Pre-emphasis - if bit 1 is 0 (dig. audio)
0 0 0	None - 2 channel audio
1 0 0	50/15 μ s - 2 channel audio
0 1 0	Reserved - 2 channel audio
1 1 0	Reserved - 2 channel audio
X X 1	Reserved - 4 channel audio
bits 3 4 5	if bit 1 is 1 (non-audio)
0 0 0	Digital data
X X X	All other states of bits 3-5 are reserved
bits 6 6	Mode
0 0	Mode 0 (defines bytes 1-3)
X X	All other states of bits 6-7 are reserved

BYTE 1 - Category Code 001						
bits 3 4 5 6	Broadcast reception of digital audio					
*	0	0	0	0	0	Japan
*	0	0	1	1		United States
*	1	0	0	0		Europe
*	0	0	0	1		Electronic software delivery
	X	X	X	X		All other states are reserved

BYTE 1 - Category Code 100						
bits 3 4 5 6	Laser Optical					
	0	0	0	0		CD - compatible with IEC-908
*	1	0	0	0		CD - not comp. with IEC-908 (magneto-optical)
	X	X	X	X		All other states are reserved

BYTE 1 - Category Code 110						
bits 3 4 5 6	Magnetic tape or disk					
	0	0	0	0		DAT
*	1	0	0	0		Digital audio sound VCR
	X	X	X	X		All other states are reserved

BYTE 1 - Category Code 101						
bits 3 4 5 6	Musical Instruments, mics, etc.					
*	0	0	0	0		Synthesizer
*	1	0	0	0		Microphone
	X	X	X	X		All other states are reserved

BYTE 1									
bits 0 1 2 3 4 5 6	Category Code								
	0	0	0	0	0	0	General		
*					0	0	1	Experimental	
					X	X	X	Reserved	
*	0	0	0	1		X	X	X	Solid state memory
*	0	0	1	X		X	X	X	Broadcast recep. of digital audio
	0	1	0	X		X	X	X	Digital/digital converters
*	0	1	1	0		0	X	X	A/D converters w/o copyright
*					1	X	X		A/D converters w/ copyright (using Copy and L bits)
*	0	1	1	1		X	X	X	Broadcast recep. of digital audio
	1	0	0	X		X	X	X	Laser-optical
*	1	0	1	X		X	X	X	Musical Instruments, mics, etc.
	1	1	0	X		X	X	X	Magnetic tape or disk
	1	1	1	X		X	X	X	Reserved

bit 7		L: Generation Status.	
		Only category codes:001XXXX, 0111XXX,100XXXX	
*	0	Original/Commercially pre-recorded data	
*	1	No indication or 1st generation or higher	
		All other category codes	
*	0	No indication or 1st generation or higher	
*	1	Original/Commercially pre-recorded data	

The subgroups under the category code groups listed above are described in tables below. Those not listed are reserved.

The Copy and L bits form a copy protection scheme for original works. Further explanations can be found in the proposed amendment (TC84) to IEC-958.

BYTE 1 - Category Code 010						
bits 3 4 5 6	Digital/digital conv. & signal processing					
	0	0	0	0		PCM encoder/decoder
*	0	0	1	0		Digital sound sampler
*	0	1	0	0		Digital signal mixer
*	1	1	0	0		Sample-rate converter
	X	X	X	X		All other states are reserved

BYTE 3						
bits 0 1 2 3	Fs: Sample Frequency					
	0	0	0	0		44.1 kHz
	0	1	0	0		48 kHzr
	1	1	0	0		32 kHz
	1	1	0	0		Sample-rate converter
	X	X	X	X		All other states are reserved

Table 3. Consumer Channel Status Bytes 0, 1 and 3

“Consumer use of the channel status block” will be implemented if the host sets the PRO bit to a state of logic 0. The additional following channel status bits may also be set by the host: Channel Status Byte 0, Bits 1-5; Channel Status Byte 1, Bits 0-7; and Channel Status Byte 3, Bits 0 and 1. Please refer to Table 3 for the IEC60958 definition for the setting of each bit or set of bits.

The channel status bits map to the DSP Write Data Word in the following manner (please refer to Table 7 in AN163):

Channel Status Byte 0, Bit 0 = maps to bit 8 in the DSP Write Data Word.

Channel Status Byte 0, Bits 1:5 = map to bits 9:13 in the DSP Write Data Word.

Channel Status Byte 1, Bits 0:7 = map to bits 14:21 in the DSP Write Data Word.

Channel Status Byte 3, Bits 0 and 1 = map to bits 22 and 23 in the DSP Write Data Word.

Please refer to the IEC60958 Specification for more a more detailed explanation of the channel status block definitions.

The following command performs a following messages can be used to control the Channel Status of Channel A (or Channel B):

0x800072 (or 0x800073)

0xhhhhhh (DSP Data Write Word)

writes the value of 0xhhhhhh absolutely.

0x800272 (or 0x800273)

0xhhhhhh (DSP Data Write Word; data is mask)

ANDs with the mask

0x800172 (or 0x800173)

0xhhhhhh (DSP Data Write Word; data is mask)

ORs with the mask

For example the following command sets the Channel Status Block of the Left Subframe (Channel A) for: Consumer Mode (Byte 0, Bit 0 = 0), 48 kHz Fs (Byte 3, Bit 0 and 1 = 01), Category Code = General (Byte 1, Bits 0:7 = 00000000), 2 Audio Channels without Pre-Emphasis and Copy Prohibited (Byte 0, Bits 1:5 = 00000):

0x800272

0xFFFF00

0x800172

0x800000

For example the following command sets the Channel Status Block of the Right Subframe (Channel B) for: Consumer Mode (Byte 0, Bit 0 = 0), 32 kHz Fs (Byte 3, Bits 0 and 1 = 11), Category Code = General (Byte 1, Bits 0:7 = 00000000), 2 Audio Channels without Pre-Emphasis and Copy Prohibited (Byte 0, Bits 1:5 = 00000):

0x800273

0xFFFF00

0x800173

0xC00000

The first word performs a logical “AND” of the register with the second word, which acts as a mask. The values located in the bit locations “AND’ed” with a one are preserved, while the locations “AND’ed” with a zero are cleared. The third word performs a logical “OR” of the same register with the fourth word, which contains the necessary CSW Bits which the user wants to set.

2.1.3 S/PDIF (AES/EBU) Validity Bit Control

In addition to the Channel Status Block Control, the Validity Bit in the IEC60958 stream may also be set by the host to indicate if the according audio sample is fit for conversion to analog.

The following command must be sent to SET the IEC60958 Validity Bit:

0x800271
0xFFBFFF

The following command must be sent to CLEAR the IEC60958 Validity Bit:

0x800171
0x004000

2.2 Application Messaging

Please refer to Section 3 “Application Messaging”, AN163 for details regarding all application messaging.

2.3 Unsolicited Messages (Read-Only)

No Write Message. No Read Request.

Unsolicited Read Response = 0x8700HH 0xhhhhh

0xHH = index, 0xhhhhh = data value

Index	Variable	Dataword Content
0x10	PLL_Out_Of_Lock	Bit 23 = 1. Bits 22:0 = Reserved.

Table 4. Unsolicited Messages

3. APPLICATION MODULES

This section describes the standard application modules available in the Crystal D.P.P. multichannel PCM post-processing application.

The following should be noted about all values in the application modules:

Variables marked by '*Default**' will only be initialized after download. These variables will retain their values after a soft reset.

Variables marked by '*Default*' will be reinitialized to the values shown in this application note after download, soft reset.

Variables marked by '†' *can* be modified during runtime of any application code. Variables NOT marked by '†' *can NOT* be modified during runtime of any application code.

Only those values which are presented as valid or which fall within the specified range should be written to the application module variables. If a value which falls outside the stated range is written

to a variable, functionality of the application is not guaranteed and erroneous output could result.

All bits that are not defined should be considered reserved and written with 0's unless specified otherwise.

For variables such as volume and scaling factors, the real number range of 0.0-1.0 is written as 0x000000-0x7FFFFFFF. This range is linear, i.e. 1/4 volume, or -12 dB, is represented as 0x1FFFFFFF and is equivalent to a value of 0.25.

The formula for converting variable settings from a hexadecimal number into dB is as follows:

$$20 * \log (\text{variable setting}/\text{max value for variable})$$

$$\text{e.g. } 20 * \log (0x1FFFFFFF/0x7FFFFFFF) == -12 \text{ dB}$$

Numbers preceded by 0x should be interpreted as hex, and numbers followed by 'b' should be interpreted as binary. All values sent to the CS49330 should be converted to hexadecimal. Likewise all values read from the part are in hexadecimal.

3.1 Audio Manager for Crystal D.P.P.

Write Opcode = 0x88; Read Opcode = 0x09; Read Response Opcode = 0x89

Write Message = 0x8800HH 0xhhhhh

Read Request Message = 0x0900HH;

Read Response Message = 0x8900HH 0xhhhhh

0xHH = index, 0xhhhhh = data value

Index	Variable	Dataword Content
0x00	AUDIO_MGR_CONTROL	<p>Bit 9 = Delay_Granularity 0/1 = ms/16 sample.</p> <p>Bit 4 = PLL_Enable = 0/1 = Disable/Enable Phase Locked Loop generation of DSP clock. It is mandatory that the PLL be enabled for the CS49330.</p> <p>Bit 0 = Kickstart_Enable = 0/1 = Disable/Enable Kickstart of application.</p> <p>Default = 0x000000</p>
0x01	NOISE_CONTROL	<p>Bit 8 = 94_Sample_Impulse_Enable = 0/1 = Disables/Enables Impulses 94 Samples apart. †</p> <p>Bit 6 = Band_Pass_Filtered_Bass_Noise_Enable = 0/1 = Disable/Enable. †</p> <p>Note: Bit 6 and Bit 4 are mutually exclusive. Set only one HIGH.</p> <p>Bit 5 = Level_Select = 0/1 = Normal Level / High Level White Noise output. Refer to Section 3.1.2 "Noise_Control: (Index 0x01)". †</p> <p>Note: Bit 5 should only be set HIGH if Bit 4 or Bit 6 has been set HIGH.</p> <p>Bit 4 = White_Noise_Enable = 0/1 = Pink/White Noise output. †</p> <p>Note: Bit 6 and Bit 4 are mutually exclusive. Set only one HIGH.</p> <p>Bits 3:0 = Output_Channel = 0...5 = L, C, R, Ls, Rs, LFE channel output. †</p> <p>Default = 0x000000</p>
0x03	PCM_PRECISION	<p>1...24 = Precision of output PCM.</p> <p>Default* = 24</p>
0x06	MASTER_VOLUME	0x800000-0x7FFFFFF (-1.0 to 1.0). Default* = 0x7FFFFFF †
0x07	L_VOLUME	0x800000-0x7FFFFFF (-1.0 to 1.0). Default* = 0x7FFFFFF †
0x08	C_VOLUME	0x800000-0x7FFFFFF (-1.0 to 1.0). Default* = 0x7FFFFFF †
0x09	R_VOLUME	0x800000-0x7FFFFFF (-1.0 to 1.0). Default* = 0x7FFFFFF †
0x0a	LS_VOLUME	0x800000-0x7FFFFFF (-1.0 to 1.0). Default* = 0x7FFFFFF †
0x0b	RS_VOLUME	0x800000-0x7FFFFFF (-1.0 to 1.0). Default* = 0x7FFFFFF †
0x0c	LFE_VOLUME	0x800000-0x7FFFFFF (-1.0 to 1.0). Default* = 0x7FFFFFF †
0x0d	MUTE	0/1 = Unmute/mute audio. This is a soft mute. Default = 0 †
0x0e	DAO0_CHANNEL ^A	0...7 = Channel type ^a for Digital Audio Output 0. Any channel may be mapped to any valid number of outputs. Default* = 0(L) †
0x0f	DAO1_CHANNEL ^A	0...7 = Channel type ^a for Digital Audio Output 1. Any channel may be mapped to any valid number of outputs. Default* = 2(R) †
0x10	DAO2_CHANNEL ^A	0...7 = Channel type ^a for Digital Audio Output 2. Any channel may be mapped to any valid number of outputs. Default* = 3(Ls) †

Table 5. Audio Manager for Crystal D.P.P.

Index	Variable	Dataword Content
0x11	DAO3_CHANNEL ^A	0...7 = Channel type ^a for Digital Audio Output 3. Any channel may be mapped to any valid number of outputs. <i>Default*</i> = 4(<i>R_s</i>) †
0x12	DAO4_CHANNEL ^A	0...7 = Channel type ^a for Digital Audio Output 4. Any channel may be mapped to any valid number of outputs. <i>Default*</i> = 1(<i>C</i>) †
0x13	DAO5_CHANNEL ^A	0...7 = Channel type ^a for Digital Audio Output 5. Any channel may be mapped to any valid number of outputs. <i>Default*</i> = 5(<i>LFE</i>) †
0x14	SAMPLING_FREQUENCY_CODE	0..2 = Sampling Frequency code to be set by host in case of PCM-only input applications. Irrelevant for non-PCM processing. 0 = 48 KHz (note b) 1 = 44.1 KHz (note c) 2 = 32 KHz (note d) <i>Default*</i> = 0
0x17	PLL_REGISTER_1	Register 1 value for Phase Locked Loop (no Fs generation). The following values should be used for each corresponding CLKIN frequency: <i>Default*</i> = 0x05F1BF
0x18	PLL_REGISTER_2	Register 2 value for Phase Locked Loop (no Fs generation). The following values should be used for each corresponding CLKIN frequency: <i>Default*</i> = 0x002F7D
0x1c	LT_VOLUME	0x800000-0x7FFFFFF (-1.0 to 1.0). <i>Default*</i> = 0x7FFFFFF †
0x1d	RT_VOLUME	0x800000-0x7FFFFFF (-1.0 to 1.0). <i>Default*</i> = 0x7FFFFFF †
0x1e	DAO6_CHANNEL ^A	0...7 = Channel type ^a for Digital Audio Output 6. Any channel may be mapped to any valid number of outputs. <i>Default*</i> = 6(<i>Lt</i>) †
0x1f	DAO7_CHANNEL ^A	0...7 = Channel type ^a for Digital Audio Output 7. Any channel may be mapped to any valid number of outputs. <i>Default*</i> = 7(<i>Rt</i>) †

Table 5. Audio Manager for Crystal D.P.P. (Continued)

- Notes:
- a. Channel type 0...7 corresponds to Channels L, C, R, Ls, Rs, LFE, Lt, and Rt respectively. Lt and Rt refer downmixed outputs. If the source made available to the decoder is a 5.1 Channel AC-3 stream, these outputs will be Pro Logic encoded and should be considered to be Lt and Rt. However, for a 2.0 Channel AC-3 stream, these outputs will be simply L and R.
 - b. Pre-loaded coefficients will provide a 80 Hz Crossover if input Fs is 48 kHz. A different set of coefficients must be downloaded for 96 kHz or 192 kHz Fs support.
 - c. Pre-loaded coefficients will provide a 80 Hz Crossover if input Fs is 44.1 kHz. A different set of coefficients must be downloaded for 88.2 kHz or 176.4 kHz Fs support.
 - d. Pre-loaded coefficients will provide a 80 Hz Crossover if input Fs is 32 kHz. A different set of coefficients must be downloaded for 64 kHz or 128 kHz Fs support.
- † See definition in AN163, page 28.
- “Default” vs. “Default*” See definition AN163, page 28.

3.1.1 Audio_Control: (Index 0x00)

Bit 4: PLL_Enable

Enables the use of the Phase Locked Loop (PLL) to generate internal DSPCLK from the desired external CLKIN.

- 0 - Disables PLL
- 1 - Enables PLL

The register values in PLL_Register_1 (0x17) and PLL_Register_2 (0x18) define the desired DSP clock and reference CLKIN used. The default values at download, setup a 86 MHz DSPCLK from a 12.288 MHz external CLKIN. These register values should be downloaded prior to Kickstart with PLL_Enable.

For other system requirements, please contact the factory for appropriate register values.

Bit 0: Kickstart Enable

Puts CS49330 into run-time mode. Indicates that all hardware and software configuration has been completed and CS49330 can start the application.

- 0 - Application continues waiting for kickstart
- 1 - Application is kickstarted

3.1.2 Noise_Control: (Index 0x01)

Switches ON Pink/White Noise in Channels L, C, R, Ls, Rs, and LFE. Pink/White noise will not be enabled unless the Output_Channel is set to a value in the range 0x0 - 0x5.

3.2 Crystal D.P.P. Manager

Write Opcode = 0x92; Read Opcode = 0x13; Read Response Opcode = 0x93

Write Message = 0x9200HH 0xhhhhh

Read Request Message = 0x1300HH;

Read Response Message = 0x9300HH 0xhhhhh

0xHH = index, 0xhhhhh = data value

Index	Variable	Dataword Content
0x00	DPP_CONTROL	<p>Bit 13:12 = Test_Modes. †</p> <p>0 = Test Mode Outputs Off.</p> <p>1 = Replaces Multichannel Data with Impulse Train @ 2048 Sample Period.</p> <p>2 = Replaces Multichannel Data with Pink Noise, White Noise or Impulse @ 94 Sample Period, depending on setting of Noise_Control in the Audio Manager.</p> <p>Bit 9 = Stereo_PCM_Input_Disable = 0/1 = Enable/Disable stereo PCM (Lk/Rk) input data.</p> <p>Note: Stereo_PCM_Input_Disable = MC_PCM_Input_Disable = 1 is illegal due to the fact there is not input and must be setup before kickstart.</p> <p>Bit 8 = Mixer_Enable = 0/1 = Disable/Enable Mixer. †</p> <p>Bit 5 = LtRt_Source = 0/1 = Pre-Mix/Post-Mix source select for LtRt downmix. †</p> <p>Bit 4 = LtRt_Downmix_Enable = 0/1 = Disable/Enable simultaneous LtRt downmix and output via IEC60958 transmitter. †</p> <p>Bit 2 = MC_LR2LsRs_Copy_Enable = 0/1 = Disable/Enable replacement of Multichannel PCM input Ls and Rs channel data with that in L and R channels, respectively. †</p> <p>Bit 1 = MC_PCM_Input_Disable = 0/1 = Enable/Disable Multichannel PCM input data.</p> <p>Note: Stereo_PCM_Input_Disable = MC_PCM_Input_Disable = 1 is illegal due to the fact there is no input and must be setup before kickstart.</p> <p>Bit 0 = Dolby_Downmix_Enable = 0/1 = Disable/Enable Dolby downmix processing. †</p> <p>Note: All other bits should be 0.</p> <p><i>Default = 0x000000 (Multichannel Pass-Through Mode)</i></p>

Table 6. Crystal D.P.P. Manager

Index	Variable	Dataword Content
0x01	INPUT_ACMOD	<p>Indicates configuration of input multichannel audio. Controller should set this up using AC-3 syntax based on audio configuration reported by preceding decoder. †</p> <ul style="list-style-type: none"> 0 = Ch1/Ch2 dual mono (1+1) 1 = C (1/0) 2 = L, R (2/0) 3 = L, C, R (3/0) 4 = L, R, S (2/1) 5 = L, C, R, S (3/1) 6 = L, R, Ls, Rs (2/2) 7 = L, C, R, Ls, Rs (3/2) <p><i>Default = 0x000007</i></p>
0x02	INPUT_BSMOD	<p>Indicates Karaoke mode of input multichannel audio. Controller should set this up using AC-3 syntax based on Karaoke configuration reported by preceding decoder (typically AC-3 only). †</p> <ul style="list-style-type: none"> 0 = Main audio service, not Karaoke 1...6 = Not used in receiver products. 7 = Main audio service, Karaoke (acmod > 1) <p><i>Default = 0x000000</i></p>
0x03	OUTPUT_MODE	<p>Desired output speaker configuration. †</p> <ul style="list-style-type: none"> 0 = 2/0 Lt, Rt Dolby Surround compatible (equation in AN163). 1 = 1/0 C 2 = 2/0 L, R 3 = 3/0 L, C, R 4 = 2/1 L, R, S (Ls = Rs = S - 3 dB) 5 = 3/1 L, C, R, S (Ls = Rs = S - 3 dB) 6 = 2/2 L, R, Ls, Rs 7 = 3/2 L, C, R, Ls, Rs <p>Note: Undesired Channel outputs should be explicitly muted by setting the corresponding Ch_Vol (see Section 3.1 "Audio Manager for Crystal D.P.P.") to 0.0</p> <p><i>Default = 0x000007</i></p>
0x04	DUALMODE	<p>Desired output configuration in case of dual mono (Input_acmod=0). †</p> <ul style="list-style-type: none"> 0 = Stereo 1 = Left Mono 2 = Right Mono 3 = Mixed-Mono. <p><i>Default = 0x000000</i></p>

Table 6. Crystal D.P.P. Manager (Continued)

Index	Variable	Dataword Content
0x05	KARAOKE_CAPABLE_ENABLE	0/1 = Disables/Enables Karaoke capable downmix mode (default is Karaoke aware) in case multi-channel input is indicated as Karaoke (Input_bsmode = 7 and Input_acmode > 1). † <i>Default = 0x000000</i>
0x06	DOWNMIX_SLEV	Nominal downmix level to be used for surrounds. Controller should set this based on surround mix level reported by preceding decoder. † <i>Default = 0x5a827a = -3 dB</i>
0x07	DOWNMIX_CLEV	Nominal downmix level to be used for center. Controller should set this based on center mix level reported by preceding decoder. † <i>Default = 0x5a827a = -3 dB</i>
0x08	COMPRESSION_CONTROL	Indicates compression control mode used in preceding decoder. † Valid only for AC3 as: <ul style="list-style-type: none"> 0 = Custom Mode 0 (Analog Dialnorm) 1 = Custom Mode 1 (Digital Dialnorm) 2 = Line Out Mode 3 = RF Remodulation Mode For modes 0 and 1, 11 dB attenuation is performed before downmix. For modes 2 and 3, no attenuation is performed since the preceding decoder will ensure headroom by applying dynamic range compression (only for AC-3). Note: For all multichannel sources other than AC-3, maintain the default value of 0x000001. The resulting 11 dB attenuation should be compensated in the analog domain. <i>Default = 0x000001</i>
0x09	MIXER_COEFF_L2L	Mixer configuration parameter, scales Left channel of multichannel PCM as summed forward into Left channel. † <i>Default = 0x7ffff = 0dB</i>
0x0a	MIXER_COEFF_LK2L	Mixer configuration parameter, scales Left channel of mix-in stereo input as summed forward into Left channel. † <i>Default = 0x000000 = 0</i>
0x0b	MIXER_COEFF_RK2L	Mixer configuration parameter, scales Right channel of mix-in stereo input as summed forward into Left channel. † <i>Default = 0x000000 = 0</i>
0x0c	MIXER_COEFF_C2C	Mixer configuration parameter, scales Center channel of multichannel PCM as summed forward into Center channel. † <i>Default = 0x7ffff = 0dB</i>
0x0d	MIXER_COEFF_LK2C	Mixer configuration parameter, scales Left channel of mix-in stereo input as summed forward into Center channel. † <i>Default = 0x000000 = 0</i>

Table 6. Crystal D.P.P. Manager (Continued)

Index	Variable	Dataword Content
0x0e	MIXER_COEFF_RK2C	Mixer configuration parameter, scales Right channel of mix-in stereo input as summed forward into Center channel. † <i>Default = 0x000000 = 0</i>
0x0f	MIXER_COEFF_R2R	Mixer configuration parameter, scales Right channel of multichannel PCM as summed forward into Right channel. † <i>Default = 0x7fffff = 0 dB</i>
0x10	MIXER_COEFF_LK2R	Mixer configuration parameter, scales Left channel of mix-in stereo input as summed forward into Right channel. † <i>Default = 0x000000 = 0</i>
0x11	MIXER_COEFF_RK2R	Mixer configuration parameter, scales Right channel of mix-in stereo input as summed forward into Right channel. † <i>Default = 0x000000 = 0</i>
0x12	MIXER_COEFF_LS2LS	Mixer configuration parameter, scales Left Surround channel of multichannel PCM as summed forward into Left Surround channel. † <i>Default = 0x7fffff = 0 dB</i>
0x13	MIXER_COEFF_LK2LS	Mixer configuration parameter, scales Left channel of mix-in stereo input as summed forward into Left Surround channel. † <i>Default = 0x000000 = 0</i>
0x14	MIXER_COEFF_RK2LS	Mixer configuration parameter, scales Right channel of mix-in stereo input as summed forward into Left Surround channel. † <i>Default = 0x000000 = 0</i>
0x15	MIXER_COEFF_RS2RS	Mixer configuration parameter, scales Right Surround channel of multichannel PCM as summed forward into Right Surround channel. † <i>Default = 0x7fffff = 0 dB</i>
0x16	MIXER_COEFF_LK2RS	Mixer configuration parameter, scales Left channel of mix-in stereo input as summed forward into Right Surround channel. † <i>Default = 0x000000 = 0</i>
0x17	MIXER_COEFF_RK2RS	Mixer configuration parameter, scales Right channel of mix-in stereo input as summed forward into Right Surround channel. † <i>Default = 0x000000 = 0</i>
0x18	MIXER_COEFF_LFE2LFE	Mixer configuration parameter, scales LFE channel of multichannel PCM as summed forward into LFE channel. † <i>Default = 0x7fffff = 0dB</i>
0x19	MIXER_COEFF_LK2LFE	Mixer configuration parameter, scales Left channel of mix-in stereo input as summed forward into LFE channel. † <i>Default = 0x000000 = 0</i>
0x1a	MIXER_COEFF_RK2LFE	Mixer configuration parameter, scales Right channel of mix-in stereo input as summed forward into LFE channel. † <i>Default = 0x000000 = 0</i>

Table 6. Crystal D.P.P. Manager (Continued)

Notes: † See definition in AN163, page 28.

3.2.1 Mixer Coefficients

Mixer_Coeff_L2L, *Mixer_Coeff_Lk2L*,
Mixer_Coeff_Rk2L,..., *Mixer_Coeff_Sb2Sb*,
Mixer_Coeff_Lk2Sb and *Mixer_Coeff_Rk2Sb* are
 Mixer scaling coefficients used in the mixing of
 stereo input (Lk and Rk channels) with
 multichannel input (L, C, R, Ls, Rs and LFE
 channels).

3.2.2 Karaoke Capable Function

Although this is part of AC-3, it is included here
 since it may be reused with other multichannel
 sources.

In a karaoke bit stream, 3 channels should be
 downmixed according to user specification. They
 are M (e.g., guide melody), and V1, V2 (e.g., one
 or two vocal tracks). The downmix coefficients
 used are determined by the number of output front
 channels.

3.2.3 Karaoke Downmix Coefficients:

- 1 front channel

$$Ck = mlev * M + v1lev * V1 + v2lev * V2.$$

- 2 front channels

$$Lk = mllev * M + v1llev * V1 + v2llev * V2.$$

$$Rk = mrlev * M + v1rlev * V1 + v2rlev * V2.$$

Notes: 1. $0 \leq mlev + v1lev + v2lev \leq 0x7ffff$

2. $0 \leq mrlev + v1rlev + v2rlev \leq 0x7ffff$

- 3 front channels

$$Ck = mcpan * M + v1cpan * V1 + v2cpan * V2.$$

$$Lk = mlpan * M + v1lpan * V1 + v2lpan * V2.$$

$$Rk = mrpan * M + v1rpan * V1 + v2rpan * V2.$$

Notes: 1. $0 \leq mcpan + v1cpan + v2cpan \leq 0x7ffff$;

2. $0 \leq mlpan + v1lpan + v2lpan \leq 0x7ffff$;

3. $0 \leq mrpan + v1rpan + v2rpan \leq 0x7ffff$;

3.3 Dual-Precision Bass Manager

Write Opcode = 0x94; Read Opcode = 0x15; Read Response Opcode = 0x95

Write = 0x9400HH 0xhhhhh

Read Request = 0x1500HH;

Read Response = 0x9500HH 0xhhhhh

0xHH = index, 0xhhhhh = data value

Index	Variable	Dataword Content
0x00	BASS_MGR_CONTROL	<p>Bit 16 = LFE_To_Sub_Enable = 0/1 = Disable/Enable LFE Only to subwoofer. If 0, Sum is sent to Subwoofer. †</p> <p>Bit 12 = LPF_Enable = 0/1 = Disable/Enable LPF at the output of summer. †</p> <p>Bit 8 = HPF_L_Enable = 0/1/ = Disable/Enable L channel HPF. †</p> <p>Bit 7 = HPF_C_Enable = 0/1/ = Disable/Enable C channel HPF. †</p> <p>Bit 6 = HPF_R_Enable = 0/1/ = Disable/Enable R channel HPF. †</p> <p>Bit 5 = HPF_Ls_Enable = 0/1/ = Disable/Enable Ls channel HPF. †</p> <p>Bit 4 = HPF_Rs_Enable = 0/1/ = Disable/Enable Rs channel HPF. †</p> <p>Bit 0 = Bass_Mgr_Enable = 0/1 = Disable/Enable Bass Manager post-processing.</p> <p>Note: All other bits should be 0.</p> <p>Default = 0x000000</p>
0x01	BASS_MGR_INPUT_L_LEVEL	<p>0.0-1.0 = Level adjustment for input L channel pass-through. †</p> <p>Default* = 0x7ffffff = 0 dB</p>
0x02	BASS_MGR_INPUT_C_LEVEL	<p>0.0-1.0 = Level adjustment for input C channel input pass-through. †</p> <p>Default* = 0x7ffffff = 0 dB</p>
0x03	BASS_MGR_INPUT_R_LEVEL	<p>0.0-1.0 = Level adjustment for input R channel input pass-through. †</p> <p>Default* = 0x7ffffff = 0 dB</p>
0x04	BASS_MGR_INPUT_LS_LEVEL	<p>0.0-1.0 = Level adjustment for input Ls channel pass-through. †</p> <p>Default* = 0x7ffffff = 0 dB</p>
0x05	BASS_MGR_INPUT_RS_LEVEL	<p>0.0-1.0 = Level adjustment for input Rs channel pass-through. †</p> <p>Default* = 0x7ffffff = 0 dB</p>

Table 7. Dual-Precision Bass Manager

Index	Variable	Dataword Content
0x06	BASS_MGR_INPUT_LFE_LEVEL	0.0-1.0 = Level adjustment for input LFE channel pass-through. † <i>Default* = 0x7ffffff = 0 dB</i>
0x07	RESERVED	Reserved.
0x08	BASS_MGR_SUM_OUTPUT_L_LEVEL	0.0-1.0 = Level adjustment for bass summer output contribution to L channel output. † <i>Default* = 0</i>
0x09	BASS_MGR_SUM_OUTPUT_C_LEVEL	0.0-1.0 = Level adjustment for bass summer output contribution to C channel output. † <i>Default* = 0</i>
0x0a	BASS_MGR_SUM_OUTPUT_R_LEVEL	0.0-1.0 = Level adjustment for bass summer output contribution to R channel output. † <i>Default* = 0</i>
0x0b	BASS_MGR_SUM_OUTPUT_LS_LEVEL	0.0-1.0 = Level adjustment for bass summer output contribution to Ls channel output. † <i>Default* = 0</i>
0x0c	BASS_MGR_SUM_OUTPUT_RS_LEVEL	0.0-1.0 = Level adjustment for bass summer output contribution to Rs channel output. † <i>Default* = 0</i>
0x0d	RESERVED	Reserved.
0x0e	BASS_MGR_LFE_L_LEVEL	0.0-1.0 = Level adjustment for input LFE contribution to L channel output. † <i>Default* = 0</i>
0x0f	BASS_MGR_LFE_C_LEVEL	0.0-1.0 = Level adjustment for input LFE contribution to C channel output. † <i>Default* = 0</i>
0x10	BASS_MGR_LFE_R_LEVEL	0.0-1.0 = Level adjustment for input LFE contribution to R channel output. † <i>Default* = 0f</i>
0x11	BASS_MGR_LFE_LS_LEVEL	0.0-1.0 = Level adjustment for input LFE contribution to Ls channel output. † <i>Default* = 0</i>
0x12	BASS_MGR_LFE_RS_LEVEL	0.0-1.0 = Level adjustment for input LFE contribution to Ls channel output. † <i>Default* = 0</i>
0x13	RESERVED	Reserved.
0x14	BASS_MGR_SUM_INPUT_L_LEVEL	0.0-1.0 = Level adjustment for input L channel contribution to bass summer input. † <i>Default* = 0x16c311 = -15 dB</i>

Table 7. Dual-Precision Bass Manager (Continued)

Index	Variable	Dataword Content
0x15	BASS_MGR_SUM_INPUT_C_LEVEL	0.0-1.0 = Level adjustment for input C channel contribution to bass summer input. † <i>Default*</i> = 0x16c311 = -15 dB
0x16	BASS_MGR_SUM_INPUT_R_LEVEL	0.0-1.0 = Level adjustment for input R channel contribution to bass summer input. † <i>Default*</i> = 0x16c311 = -15 dB
0x17	BASS_MGR_SUM_INPUT_LS_LEVEL	0.0-1.0 = Level adjustment for input Ls channel contribution to bass summer input. † <i>Default*</i> = 0x16c311 = -15 dB
0x18	BASS_MGR_SUM_INPUT_RS_LEVEL	0.0-1.0 = Level adjustment for input Rs channel contribution to bass summer input. † <i>Default*</i> = 0x16c311 = -15 dB
0x19	BASS_MGR_SUM_INPUT_LFE_LEVEL	0.0-1.0 = Level adjustment for input LFE channel contribution to bass summer. † <i>Default*</i> = 0x47facd = -5 dB
0x1a	RESERVED	Reserved.
0x1b	RESERVED	Reserved.
0x1c	RESERVED	Reserved.
0x1d	RESERVED	Reserved.
0x1e	BASS_MGR_LPF_48_B0	0.0-1.0 = b0 coefficient for Low Pass Filter, Fs=48 KHz. <i>Default*</i> = 0x000072
0x1f	BASS_MGR_LPF_48_B1	0.0-1.0 = b1 coefficient for Low Pass Filter, Fs=48 KHz. <i>Default*</i> = 0x0000e4
0x20	BASS_MGR_LPF_48_B2	0.0-1.0 = b2 coefficient for Low Pass Filter, Fs=48 KHz. <i>Default*</i> = 0x000072
0x21	BASS_MGR_LPF_48_A1	0.0-1.0 = a1 coefficient for Low Pass Filter, Fs=48 KHz. <i>Default*</i> = 0x7f0d13
0x22	BASS_MGR_LPF_48_A2	0.0-1.0 = a2 coefficient for Low Pass Filter, Fs=48 KHz. <i>Default*</i> = 0xc0f124
0x23	BASS_MGR_HPF_48_B0	0.0-1.0 = b0 coefficient for High Pass Filter, Fs=48 KHz. <i>Default*</i> = 0x3f8745
0x24	BASS_MGR_HPF_48_B1	0.0-1.0 = b1 coefficient for High Pass Filter, Fs=48 KHz. <i>Default*</i> = 0x80f176
0x25	BASS_MGR_HPF_48_B2	0.0-1.0 = b2 coefficient for High Pass Filter, Fs=48 KHz. <i>Default*</i> = 0x3f8745
0x26	BASS_MGR_HPF_48_A1	0.0-1.0 = a1 coefficient for High Pass Filter, Fs=48 KHz. <i>Default*</i> = 0x7f0da6

Table 7. Dual-Precision Bass Manager (Continued)

Index	Variable	Datword Content
0x27	BASS_MGR_HPF_48_A2	0.0-1.0 = a2 coefficient for High Pass Filter, Fs=48 KHz. <i>Default* = 0xc0f092</i>
0x28	BASS_MGR_SC1_48	0.0-1.0 = Smoother coefficient 1, Fs=48 KHz. Applies to b0. <i>Default* = 0x0000ae</i>
0x29	BASS_MGR_SC2_48	0.0-1.0 = Smoother coefficient 2, Fs=48 KHz. Applies to a1. <i>Default* = 0x7FFF51</i>
0x2a	BASS_MGR_LPF_44_B0	0.0-1.0 = b0 coefficient for Low Pass Filter, Fs=44 KHz. <i>Default* = 0x000087</i>
0x2b	BASS_MGR_LPF_44_B1	0.0-1.0 = b1 coefficient for Low Pass Filter, Fs=44 KHz. <i>Default* = 0x00010e</i>
0x2c	BASS_MGR_LPF_44_B2	0.0-1.0 = b2 coefficient for Low Pass Filter, Fs=44 KHz. <i>Default* = 0x000087</i>
0x2d	BASS_MGR_LPF_44_A1	0.0-1.0 = a1 coefficient for Low Pass Filter, Fs=44 KHz. <i>Default* = 0x7ef797</i>
0x2e	BASS_MGR_LPF_44_A2	0.0-1.0 = a2 coefficient for Low Pass Filter, Fs=44 KHz. <i>Default* = 0xc1064b</i>
0x2f	BASS_MGR_HPF_44_B0	0.0-1.0 = b0 coefficient for High Pass Filter, Fs=44 KHz. <i>Default* = 0x3f7ca3</i>
0x30	BASS_MGR_HPF_44_B1	0.0-1.0 = b1 coefficient for High Pass Filter, Fs=44 KHz. <i>Default* = 0x8106ba</i>
0x31	BASS_MGR_HPF_44_B2	0.0-1.0 = b2 coefficient for High Pass Filter, Fs=44 KHz. <i>Default* = 0x3f7ca3</i>
0x32	BASS_MGR_HPF_44_A1	0.0-1.0 = a1 coefficient for High Pass Filter, Fs=44 KHz. <i>Default* = 0x7ef838</i>
0x33	BASS_MGR_HPF_44_A2	0.0-1.0 = a2 coefficient for High Pass Filter, Fs=44 KHz. <i>Default* = 0xc105ad</i>
0x34	BASS_MGR_SC1_44	0.0-1.0 = Smoother coefficient 1, Fs=44 KHz. Applies to b0. <i>Default* = 0x0000ae</i>
0x35	BASS_MGR_SC2_44	0.0-1.0 = Smoother coefficient 2, Fs=44 KHz. Applies to a1. <i>Default* = 0x7FFF51</i>
0x36	BASS_MGR_LPF_32_B0	0.0-1.0 = b0 coefficient for Low Pass Filter, Fs=32 KHz. <i>Default* = 0x000100</i>
0x37	BASS_MGR_LPF_32_B1	0.0-1.0 = b1 coefficient for Low Pass Filter, Fs=32 KHz. <i>Default* = 0x000200</i>
0x38	BASS_MGR_LPF_32_B2	0.0-1.0 = b2 coefficient for Low Pass Filter, Fs=32 KHz. <i>Default* = 0x000100</i>

Table 7. Dual-Precision Bass Manager (Continued)

Index	Variable	Dataword Content
0x39	BASS_MGR_LPF_32_A1	0.0-1.0 = a1 coefficient for Low Pass Filter, Fs=32 KHz. <i>Default* = 0x7e939f</i>
0x3a	BASS_MGR_LPF_32_A2	0.0-1.0 = a2 coefficient for Low Pass Filter, Fs=32 KHz. <i>Default* = 0xc1685f</i>
0x3b	BASS_MGR_HPF_32_B0	0.0-1.0 = b0 coefficient for High Pass Filter, Fs=32 KHz. <i>Default* = 0x2a77ee</i>
0x3c	BASS_MGR_HPF_32_B1	0.0-1.0 = b1 coefficient for High Pass Filter, Fs=32 KHz. <i>Default* = 0xf8c361</i>
0x3d	BASS_MGR_HPF_32_B2	0.0-1.0 = b2 coefficient for High Pass Filter, Fs=32 KHz. <i>Default* = 0x2a77ee</i>
0x3e	BASS_MGR_HPF_32_A1	0.0-1.0 = a1 coefficient for High Pass Filter, Fs=32 KHz. <i>Default* = 0x7e947c</i>
0x3f	BASS_MGR_HPF_32_A2	0.0-1.0 = a2 coefficient for High Pass Filter, Fs=32 KHz. <i>Default* = 0xc16787</i>
0x40	BASS_MGR_SC1_32	0.0-1.0 = Smoother coefficient 1, Fs=32 KHz. Applies to b0. <i>Default* = 0x0000ae</i>
0x41	BASS_MGR_SC2_32	0.0-1.0 = Smoother coefficient 2, Fs=32 KHz. Applies to a1. <i>Default* = 0x7FFF51</i>

Table 7. Dual-Precision Bass Manager (Continued)

Notes: † See definition in AN163, page 28.

“Default” vs. “Default*” See definition in AN163, page 28.

3.3.1 Understanding the Dual-Precision Bass Manager

The Dual-Precision Bass Manager is best described with the use of a block diagram. Figure shows the topology of the filters used for both the low-pass and the high-pass filters. Note that the greyed boxes are registers of 48-bit precision, allowing extended precision, while the non-grey boxes are of 24-bit precision. The coefficients of LPF and HPF represent the second order digital filter $H(z) = (b_0 + b_1z[-1] + b_2z[-2]) / (1 - a_1z[-1] - a_2z[-2])$. The LPF implementation cascades 2 such identical filters to produce a 4th order filter Linkwitz-Riley filter. Therefore, the corner frequency of the LPF is 6dB. Hence, if it is important to ensure a particular overall 3 dB corner frequency (rather than other attenuation), it is required to specially design the

individual LPF and HPF components to have appropriate attenuation at this desired corner frequency.

The default values (shown in the Table 7) have been designed to result in an 3 dB corner frequency of 80 Hz for the HPF and 6 dB corner frequency of 80 Hz for LPF.

Figure 3 shows the processing unit on each of the output channels (except the LFE). Figure 4 shows the summing module used to redirect bass to the subwoofer channel.

For some typical Bass Manager configuration examples please refer to Section 4.2 “Generalized Bass Manager for Dolby Digital, DTS, MP3, MPEG Multichannel, AAC and Crystal Original Surround”, AN163.

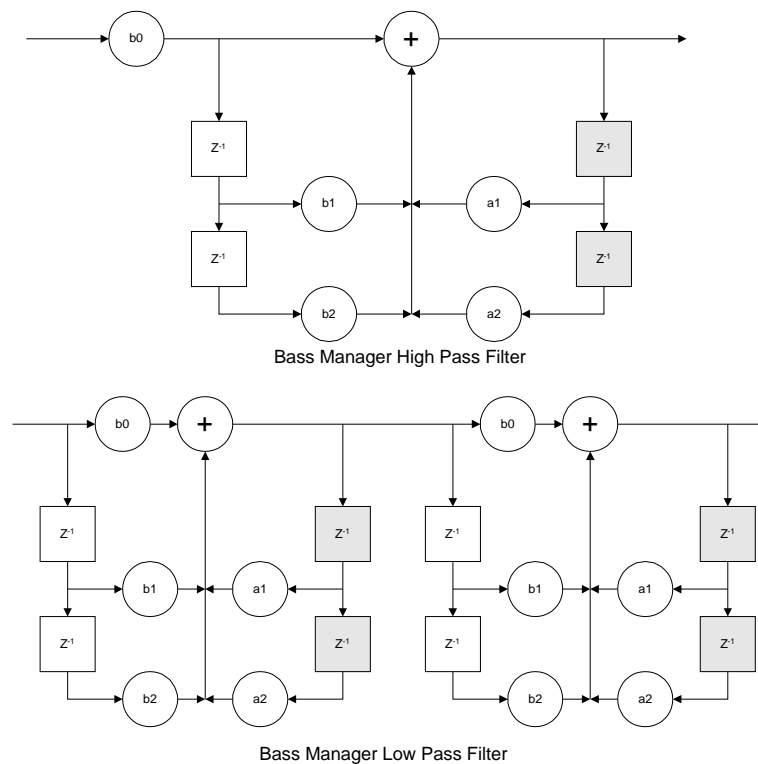

Figure 2. Filter Topology of Dual-Precision Bass Manager

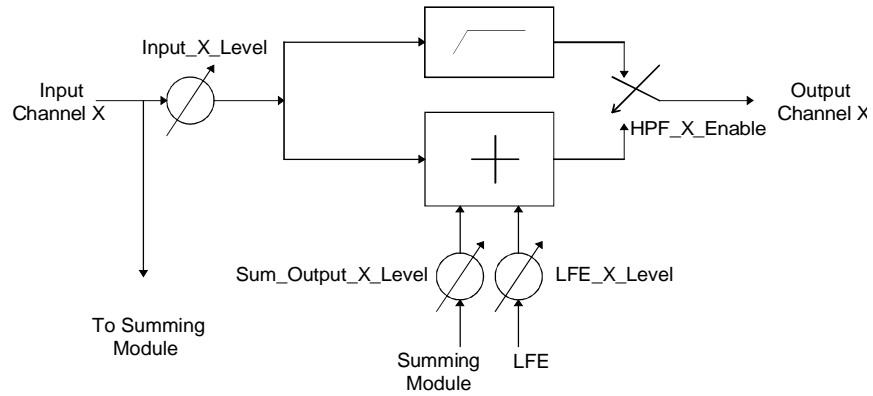

Figure 3. Bass Manager Processing Unit

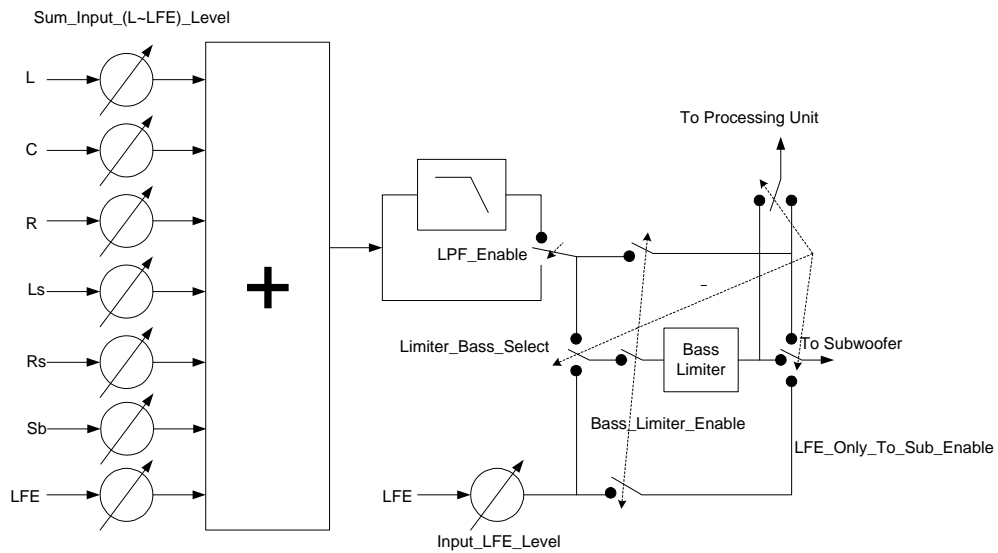

Figure 4. Subwoofer Summing Module

3.4 Tone Control and 3-Band Parametric Equalization Manger

Write Opcode = 0x9A; Read Opcode = 0x1B; Read Response Opcode = 0x9B

Write Message = 0x9A00HH 0xhhhhh

Read Request Message = 0x1B00HH;

Read Response Message = 0x9B00HH 0xhhhhh

0xHH = index, 0xhhhhh = data value

Index	Variable	Dataword Content
0x00	EQ_TONE_CONTROL	<p>Bit 4 = LCRLsRs_EQ_Enable = 0/1 = Disable/Enable 3-band Parametric EQ (pre-tone control) on L, C, R, Ls, and Rs output channels. †</p> <p>Bit 0 = LCRLsRs_Tone_Control_Enable = 0/1 = Disable/Enable Tone Control (Bass/Treble) just before Bass Manager on L, C, R, Ls, and Rs output channels. †</p> <p>Default = 0x000000</p>
0x01	PRE_TONE_ATTENUATION	<p>-1.0 to 1.0 in 1.23 format = Pre-Tone Control attenuation scale factor to setup desired headroom for Tone control for all channels. †</p> <p>Default* = 0.25 (0x200000)</p>
0x02	L_BASS_LEVEL	<p>-4.0 to 4.0 in 3.21 format = L Channel Bass level setting = $10^{(dB/20)}$ - 1.0. †</p> <p>Default* = 0.0</p>
0x03	L_TREBLE_LEVEL	<p>-4.0 to 4.0 in 3.21 format = L Channel Treble level setting = $10^{(dB/20)}$ - 1.0. †</p> <p>Default* = 0.0</p>
0x04	C_BASS_LEVEL	<p>-4.0 to 4.0 in 3.21 format = C Channel Bass level setting = $10^{(dB/20)}$ - 1.0. †</p> <p>Default* = 0.0</p>
0x05	C_TREBLE_LEVEL	<p>-4.0 to 4.0 in 3.21 format = C Channel Treble level setting = $10^{(dB/20)}$ - 1.0. †</p> <p>Default* = 0.0</p>
0x06	R_BASS_LEVEL	<p>-4.0 to 4.0 in 3.21 format = R Channel Bass level setting = $10^{(dB/20)}$ - 1.0. †</p> <p>Default* = 0.0</p>
0x07	R_TREBLE_LEVEL	<p>-4.0 to 4.0 in 3.21 format = R Channel Treble level setting = $10^{(dB/20)}$ - 1.0. †</p> <p>Default* = 0.0</p>
0x08	LS_BASS_LEVEL	<p>-4.0 to 4.0 in 3.21 format = Ls Channel Bass level setting = $10^{(dB/20)}$ - 1.0. †</p> <p>Default* = 0.0</p>

Table 8. Tone Control + 3-Band Parametric EQ Manager

Index	Variable	Dataword Content
0x09	LS_TREBLE_LEVEL	-4.0 to 4.0 in 3.21 format = Ls Channel Treble level setting = $10^{(dB/20)} - 1.0$. † <i>Default* = 0.0</i>
0x0a	RS_BASS_LEVEL	-4.0 to 4.0 in 3.21 format = Rs Channel Bass level setting = $10^{(dB/20)} - 1.0$. † <i>Default* = 0.0</i>
0x0b	RS_TREBLE_LEVEL	-4.0 to 4.0 in 3.21 format = Rs Channel Treble level setting = $10^{(dB/20)} - 1.0$. † <i>Default* = 0.0</i>
0x0c	RESERVED	Reserved.
0x0d	RESERVED	Reserved.
0x0e	BASS_LPF_B0	-1.0 to 1.0 in 1.23 format = I order b0 filter coefficient for LPF (default corner=200 Hz at Fs=48 KHz). Note: b1 = b0 assumed for LPF. <i>Default* = 0.01292157 (0x01a76a).</i>
0x0f	BASS_LPF_A1	-1.0 to 1.0 in 1.23 format = I order a1 filter coefficient for LPF (default corner=200 Hz at Fs=48 KHz). <i>Default* = 0.9741567 (0x7cb12b)</i>
0x10	TREBLE_HPF_B0	-1.0 to 1.0 in 1.23 format = I order b0 filter coefficient for HPF (default corner=6000 Hz at Fs=48 KHz). Note: b1 = - b0 assumed for HPF. <i>Default* = 0.7071067 (0x5a8279).</i>
0x11	TREBLE_HPF_A1	-1.0 to 1.0 in 1.23 format = I order a1 filter coefficient for HPF (default corner=6000 Hz at Fs=48 KHz). <i>Default* = 0.41421353 (0x3504f3).</i>
0x12	PRE_L_EQ_ATTENUATION	-1.0 to 1.0 in 1.23 format = Pre-L_EQ attenuation scale factor to setup desired headroom for L_EQ filtering. † <i>Default* = 1.0</i>
0x13	L_EQ0_B2	-4.0 to 4.0 in 3.21 format = Biquad coefficient for L_EQ Filter 0. <i>Default* = 0.0</i>
0x14	L_EQ0_B1	-4.0 to 4.0 in 3.21 format = Biquad coefficient for L_EQ Filter 0. <i>Default* = 0.0</i>
0x15	L_EQ0_B0	-4.0 to 4.0 in 3.21 format = Biquad coefficient for L_EQ Filter 0. <i>Default* = 1.0 (0x200000)</i>
0x16	L_EQ0_A2	-4.0 to 4.0 in 3.21 format = Biquad coefficient for L_EQ Filter 0. <i>Default* = 0.0</i>
0x17	L_EQ0_A1	-4.0 to 4.0 in 3.21 format = Biquad coefficient for L_EQ Filter 0. <i>Default* = 0.0</i>

Table 8. Tone Control + 3-Band Parametric EQ Manager (Continued)

Index	Variable	Dataword Content
0x18	L_EQ1_B2	-4.0 to 4.0 in 3.21 format = Biquad coefficient for L_EQ Filter 1. <i>Default* = 0.0</i>
0x19	L_EQ1_B1	-4.0 to 4.0 in 3.21 format = Biquad coefficient for L_EQ Filter 1. <i>Default* = 0.0</i>
0x1a	L_EQ1_B0	-4.0 to 4.0 in 3.21 format = Biquad coefficient for L_EQ Filter 1. <i>Default* = 1.0 (0x200000)</i>
0x1b	L_EQ1_A2	-4.0 to 4.0 in 3.21 format = Biquad coefficient for L_EQ Filter 1. <i>Default* = 0.0</i>
0x1c	L_EQ1_A1	-4.0 to 4.0 in 3.21 format = Biquad coefficient for L_EQ Filter 1. <i>Default* = 0.0</i>
0x1d	L_EQ2_B2	-4.0 to 4.0 in 3.21 format = Biquad coefficient for L_EQ Filter 2. <i>Default* = 0.0</i>
0x1e	L_EQ2_B1	-4.0 to 4.0 in 3.21 format = Biquad coefficient for L_EQ Filter 2. <i>Default* = 0.0</i>
0x1f	L_EQ2_B0	-4.0 to 4.0 in 3.21 format = Biquad coefficient for L_EQ Filter 2. <i>Default* = 1.0 (0x200000)</i>
0x20	L_EQ2_A2	-4.0 to 4.0 in 3.21 format = Biquad coefficient for L_EQ Filter 2. <i>Default* = 0.0</i>
0x21	L_EQ2_A1	-4.0 to 4.0 in 3.21 format = Biquad coefficient for L_EQ Filter 2. <i>Default* = 0.0</i>
0x22	POST_L_EQ_GAIN	-32.0 to 32.0 in 6.18 format = Post-L_EQ gain scale factor to compensate for Pre-L_EQ attenuation and L_EQ filter gains. † <i>Default* = 1.0 (0x040000)</i>
0x23	PRE_C_EQ_ATTENUATION	-1.0 to 1.0 in 1.23 format = Pre-C_EQ attenuation scale factor to setup desired headroom for C_EQ filtering. † <i>Default* = 1.0</i>
0x24	C_EQ0_B2	-4.0 to 4.0 in 3.21 format = Biquad coefficient for C_EQ Filter 0. <i>Default* = 0.0</i>
0x25	C_EQ0_B1	-4.0 to 4.0 in 3.21 format = Biquad coefficient for C_EQ Filter 0. <i>Default* = 0.0</i>
0x26	C_EQ0_B0	-4.0 to 4.0 in 3.21 format = Biquad coefficient for C_EQ Filter 0. <i>Default* = 1.0 (0x200000)</i>
0x27	C_EQ0_A2	-4.0 to 4.0 in 3.21 format = Biquad coefficient for C_EQ Filter 0. <i>Default* = 0.0</i>
0x28	C_EQ0_A1	-4.0 to 4.0 in 3.21 format = Biquad coefficient for C_EQ Filter 0. <i>Default* = 0.0</i>

Table 8. Tone Control + 3-Band Parametric EQ Manager (Continued)

Index	Variable	Dataword Content
0x29	C_EQ1_B2	-4.0 to 4.0 in 3.21 format = Biquad coefficient for C_EQ Filter 1. <i>Default* = 0.0</i>
0x2a	C_EQ1_B1	-4.0 to 4.0 in 3.21 format = Biquad coefficient for C_EQ Filter 1. <i>Default* = 0.0</i>
0x2b	C_EQ1_B0	-4.0 to 4.0 in 3.21 format = Biquad coefficient for C_EQ Filter 1. <i>Default* = 1.0 (0x200000)</i>
0x2c	C_EQ1_A2	-4.0 to 4.0 in 3.21 format = Biquad coefficient for C_EQ Filter 1. <i>Default* = 0.0</i>
0x2d	C_EQ1_A1	-4.0 to 4.0 in 3.21 format = Biquad coefficient for C_EQ Filter 1. <i>Default* = 0.0</i>
0x2e	C_EQ2_B2	-4.0 to 4.0 in 3.21 format = Biquad coefficient for C_EQ Filter 2. <i>Default* = 0.0</i>
0x2f	C_EQ2_B1	-4.0 to 4.0 in 3.21 format = Biquad coefficient for C_EQ Filter 2. <i>Default* = 0.0</i>
0x30	C_EQ2_B0	-4.0 to 4.0 in 3.21 format = Biquad coefficient for C_EQ Filter 2. <i>Default* = 1.0 (0x200000)</i>
0x31	C_EQ2_A2	-4.0 to 4.0 in 3.21 format = Biquad coefficient for C_EQ Filter 2. <i>Default* = 0.0</i>
0x32	C_EQ2_A1	-4.0 to 4.0 in 3.21 format = Biquad coefficient for C_EQ Filter 2. <i>Default* = 0.0</i>
0x33	POST_C_EQ_GAIN	-32.0 to 32.0 in 6.18 format = Post-C_EQ gain scale factor to compensate for Pre-C_EQ attenuation and C_EQ filter gains. † <i>Default* = 1.0 (0x040000)</i>
0x34	PRE_R_EQ_ATTENUATION	-1.0 to 1.0 in 1.23 format = Pre-R_EQ attenuation scale factor to setup desired headroom for R_EQ filtering. † <i>Default* = 1.0</i>
0x35	R_EQ0_B2	-4.0 to 4.0 in 3.21 format = Biquad coefficient for R_EQ Filter 0. <i>Default* = 0.0</i>
0x36	R_EQ0_B1	-4.0 to 4.0 in 3.21 format = Biquad coefficient for R_EQ Filter 0. <i>Default* = 0.0</i>
0x37	R_EQ0_B0	-4.0 to 4.0 in 3.21 format = Biquad coefficient for R_EQ Filter 0. <i>Default* = 1.0 (0x200000)</i>
0x38	R_EQ0_A2	-4.0 to 4.0 in 3.21 format = Biquad coefficient for R_EQ Filter 0. <i>Default* = 0.0</i>
0x39	R_EQ0_A1	-4.0 to 4.0 in 3.21 format = Biquad coefficient for R_EQ Filter 0. <i>Default* = 0.0</i>

Table 8. Tone Control + 3-Band Parametric EQ Manager (Continued)

Index	Variable	Dataword Content
0x3a	R_EQ1_B2	-4.0 to 4.0 in 3.21 format = Biquad coefficient for R_EQ Filter 1. <i>Default* = 0.0</i>
0x3b	R_EQ1_B1	-4.0 to 4.0 in 3.21 format = Biquad coefficient for R_EQ Filter 1. <i>Default* = 0.0</i>
0x3c	R_EQ1_B0	-4.0 to 4.0 in 3.21 format = Biquad coefficient for R_EQ Filter 1. <i>Default* = 1.0 (0x200000)</i>
0x3d	R_EQ1_A2	-4.0 to 4.0 in 3.21 format = Biquad coefficient for R_EQ Filter 1. <i>Default* = 0.0</i>
0x3e	R_EQ1_A1	-4.0 to 4.0 in 3.21 format = Biquad coefficient for R_EQ Filter 1. <i>Default* = 0.0</i>
0x3f	R_EQ2_B2	-4.0 to 4.0 in 3.21 format = Biquad coefficient for R_EQ Filter 2. <i>Default* = 0.0</i>
0x40	R_EQ2_B1	-4.0 to 4.0 in 3.21 format = Biquad coefficient for R_EQ Filter 2. <i>Default* = 0.0</i>
0x41	R_EQ2_B0	-4.0 to 4.0 in 3.21 format = Biquad coefficient for R_EQ Filter 2. <i>Default* = 1.0 (0x200000)</i>
0x42	R_EQ2_A2	-4.0 to 4.0 in 3.21 format = Biquad coefficient for R_EQ Filter 2. <i>Default* = 0.0</i>
0x43	R_EQ2_A1	-4.0 to 4.0 in 3.21 format = Biquad coefficient for R_EQ Filter 2. <i>Default* = 0.0</i>
0x44	POST_R_EQ_GAIN	-32.0 to 32.0 in 6.18 format = Post-R_EQ gain scale factor to compensate for Pre-R_EQ attenuation and R_EQ filter gains. † <i>Default* = 1.0 (0x040000)</i>
0x45	PRE_LS_EQ_ATTENUATION	-1.0 to 1.0 in 1.23 format = Pre-Ls_EQ attenuation scale factor to setup desired headroom for Ls_EQ filtering. † <i>Default* = 1.0</i>
0x46	LS_EQ0_B2	-4.0 to 4.0 in 3.21 format = Biquad coefficient for Ls_EQ Filter 0. <i>Default* = 0.0</i>
0x47	LS_EQ0_B1	-4.0 to 4.0 in 3.21 format = Biquad coefficient for Ls_EQ Filter 0. <i>Default* = 0.0</i>
0x48	LS_EQ0_B0	-4.0 to 4.0 in 3.21 format = Biquad coefficient for Ls_EQ Filter 0. <i>Default* = 1.0 (0x200000)</i>
0x49	LS_EQ0_A2	-4.0 to 4.0 in 3.21 format = Biquad coefficient for Ls_EQ Filter 0. <i>Default* = 0.0</i>
0x4a	LS_EQ0_A1	-4.0 to 4.0 in 3.21 format = Biquad coefficient for Ls_EQ Filter 0. <i>Default* = 0.0</i>

Table 8. Tone Control + 3-Band Parametric EQ Manager (Continued)

Index	Variable	Dataword Content
0x4b	LS_EQ1_B2	-4.0 to 4.0 in 3.21 format = Biquad coefficient for Ls_EQ Filter 1. <i>Default* = 0.0</i>
0x4c	LS_EQ1_B1	-4.0 to 4.0 in 3.21 format = Biquad coefficient for Ls_EQ Filter 1. <i>Default* = 0.0</i>
0x4d	LS_EQ1_B0	-4.0 to 4.0 in 3.21 format = Biquad coefficient for Ls_EQ Filter 1. <i>Default* = 1.0 (0x200000)</i>
0x4e	LS_EQ1_A2	-4.0 to 4.0 in 3.21 format = Biquad coefficient for Ls_EQ Filter 1. <i>Default* = 0.0</i>
0x4f	LS_EQ1_A1	-4.0 to 4.0 in 3.21 format = Biquad coefficient for Ls_EQ Filter 1. <i>Default* = 0.0</i>
0x50	LS_EQ2_B2	-4.0 to 4.0 in 3.21 format = Biquad coefficient for Ls_EQ Filter 2. <i>Default* = 0.0</i>
0x51	LS_EQ2_B1	-4.0 to 4.0 in 3.21 format = Biquad coefficient for Ls_EQ Filter 2. <i>Default* = 0.0</i>
0x52	LS_EQ2_B0	-4.0 to 4.0 in 3.21 format = Biquad coefficient for Ls_EQ Filter 2. <i>Default* = 1.0 (0x200000)</i>
0x53	LS_EQ2_A2	-4.0 to 4.0 in 3.21 format = Biquad coefficient for Ls_EQ Filter 2. <i>Default* = 0.0</i>
0x54	LS_EQ2_A1	-4.0 to 4.0 in 3.21 format = Biquad coefficient for Ls_EQ Filter 2. <i>Default* = 0.0</i>
0x55	POST_LS_EQ_GAIN	-32.0 to 32.0 in 6.18 format = Post-Ls_EQ gain scale factor to compensate for Pre-Ls_EQ attenuation and Ls_EQ filter gains. † <i>Default* = 1.0 (0x040000)</i>
0x56	PRE_RS_EQ_ATTENUATION	-1.0 to 1.0 in 1.23 format = Pre-Rs_EQ attenuation scale factor to setup desired headroom for Rs_EQ filtering. † <i>Default* = 1.0</i>
0x57	RS_EQ0_B2	-4.0 to 4.0 in 3.21 format = Biquad coefficient for Rs_EQ Filter 0. <i>Default* = 0.0</i>
0x58	RS_EQ0_B1	-4.0 to 4.0 in 3.21 format = Biquad coefficient for Rs_EQ Filter 0. <i>Default* = 0.0</i>
0x59	RS_EQ0_B0	-4.0 to 4.0 in 3.21 format = Biquad coefficient for Rs_EQ Filter 0. <i>Default* = 1.0 (0x200000)</i>
0x5a	RS_EQ0_A2	-4.0 to 4.0 in 3.21 format = Biquad coefficient for Rs_EQ Filter 0. <i>Default* = 0.0</i>
0x5b	RS_EQ0_A1	-4.0 to 4.0 in 3.21 format = Biquad coefficient for Rs_EQ Filter 0. <i>Default* = 0.0</i>

Table 8. Tone Control + 3-Band Parametric EQ Manager (Continued)

Index	Variable	Dataword Content
0x5c	RS_EQ1_B2	-4.0 to 4.0 in 3.21 format = Biquad coefficient for Rs_EQ Filter 1. <i>Default* = 0.0</i>
0x5d	RS_EQ1_B1	-4.0 to 4.0 in 3.21 format = Biquad coefficient for Rs_EQ Filter 1. <i>Default* = 0.0</i>
0x5e	RS_EQ1_B0	-4.0 to 4.0 in 3.21 format = Biquad coefficient for Rs_EQ Filter 1. <i>Default* = 1.0 (0x200000)</i>
0x5f	RS_EQ1_A2	-4.0 to 4.0 in 3.21 format = Biquad coefficient for Rs_EQ Filter 1. <i>Default* = 0.0</i>
0x60	RS_EQ1_A1	-4.0 to 4.0 in 3.21 format = Biquad coefficient for Rs_EQ Filter 1. <i>Default* = 0.0</i>
0x61	RS_EQ2_B2	-4.0 to 4.0 in 3.21 format = Biquad coefficient for Rs_EQ Filter 2. <i>Default* = 0.0</i>
0x62	RS_EQ2_B1	-4.0 to 4.0 in 3.21 format = Biquad coefficient for Rs_EQ Filter 2. <i>Default* = 0.0</i>
0x63	RS_EQ2_B0	-4.0 to 4.0 in 3.21 format = Biquad coefficient for Rs_EQ Filter 2. <i>Default* = 1.0 (0x200000)</i>
0x64	RS_EQ2_A2	-4.0 to 4.0 in 3.21 format = Biquad coefficient for Rs_EQ Filter 2. <i>Default* = 0.0</i>
0x65	RS_EQ2_A1	-4.0 to 4.0 in 3.21 format = Biquad coefficient for Rs_EQ Filter 2. <i>Default* = 0.0</i>
0x66	POST_RS_EQ_GAIN	-32.0 to 32.0 in 6.18 format = Post-Rs_EQ gain scale factor to compensate for Pre-Rs_EQ attenuation and Rs_EQ filter gains. † <i>Default* = 1.0 (0x040000)</i>

Table 8. Tone Control + 3-Band Parametric EQ Manager (Continued)

Notes: † See definition in AN163, page 28.

“Default” vs. “Default*” See definition in AN163, page 28.

3.4.1 Controlling the Level for Treble and Bass Boost/Cut

When tone control is enabled, the pre-Bass Manager channel PCM (for L, C, R, Ls and Rs) is attenuated by the Pre_EQ_Attenuation scale factor and passed through tone control shelving filters for bass and treble.

- Notes:
- 1) Pre_EQ_Attenuation affects L, C, R, Ls, and Rs channels and leaves the other channel LFE untouched at the full level. Thus, in order to equalize all the levels coming out of CS49330, the controller should set the volumes of LFE to be the same as Pre_EQ_Attenuation.
 - 2) Pre_EQ_Attenuation and the above matching volume setting will result in reduced level which has to be compensated by analog gain after the DACs. The controller has the knowledge of this attenuation setting at all times and can thus adjust the post-DAC analog gain accordingly. However, this increased digital headroom will result in smaller dynamic range numbers and thus it is recommended that a passthrough (disable Tone Control) mode be implemented for testing purposes.

For each channel (L, C, R, Ls, and Rs), the tone control module accepts independent parameters *Bass_Level* and *Treble_Level* to adjust the amount of cut/boost in the low and high frequency bands respectively for that channel.

The relationship of these user level settings to the amount of cut/boost in dB is given by:

$$Level = 10^{(Shelf_Gain \text{ in dB}/20)} - 1.0$$

or equivalently,

$$Shelf_Gain \text{ in dB} = 20 * \log_{10}(Level + 1.0)$$

where *Shelf_Gain* is positive dB for boost and negative dB for cut. *Level* is a positive scale factor for boost and negative for cut.

The following table lists the *Level* values in (Decimal and Hex) for each desired *Shelf_Gain* (dB). As can be seen, *Level* assumes values

ranging from approximately -0.75 to 3.0 for a *Shelf_Gain* range of -12 to +12 dB. In order to accommodate this range in 24-bit signed fixed point binary, the Hex values are all represented in 3.21 format.

The above table can be stored in the microcontroller and used to look up the dataword for each level in the CS49330 message for a given user setting. In order to conserve storage space, the lower byte of each 24-bit Hex dataword above can be forced to zero without significant loss of accuracy in the actual bass/treble cut or boost.

Shelf_Gain (dB)	Level (Decimal)	Level (Hex 3.21)
-12	-0.74881136	0xe809bd
-11	-0.71816171	0xe904d2
-10	-0.68377223	0xea1e8a
-9	-0.64518661	0xeb5aa2
-8	-0.60189283	0xecbd4b
-7	-0.55331641	0xee4b3b
-6	-0.49881277	0xf009ba
-5	-0.43765867	0xf1feb3
-4	-0.36904266	0xf430cd
-3	-0.29205422	0xf6a77e
-2	-0.20567177	0xf96b23
-1	-0.10874906	0xfc8521
0	0.0	0x000000
1	0.12201845	0x03e793
2	0.25892541	0x08491e
3	0.41253754	0x0d3382
4	0.58489319	0x12b772
5	0.77827941	0x18e7aa
6	0.99526231	0x1fd930
7	1.2387211	0x27a39a
8	1.5118864	0x306160
9	1.8183829	0x3a3031
10	2.1622777	0x453161
11	2.5481339	0x518a50
12	2.9810717	0x5f64f1

Table 9. Shelf Gain Values for Tone Control

3.4.2 Controlling the Corner Frequencies of the LPF/HPF for Bass and Treble Control

The tone control module implements shelving filters using a I order LPF and a I order HPF whose default corner frequencies are 200 Hz and 6000 Hz respectively at $F_s=48$ KHz.

Different filter coefficients can be downloaded (before kickstart only) for any desired corner frequencies or to match any change in F_s .

Only b_0 and a_1 are required to be downloaded since it is assumed that $b_1 = b_0$ for the LPF, and $b_1 = -b_0$ for the HPF. These values can be obtained using any standard filter design procedure for I order LPF and HPF with unity gain in the passband. The coefficients are all expected to be downloaded in 1.23 format before kickstart.

Note: LPF/HPF coefficients should be setup before kickstart and should not be modified on the fly during runtime.

3.4.3 Controlling the Three-band Parametric EQ

An independent 3-band Parametric EQ is available for each output full-bandwidth channel (L, C, R, Ls, and Rs) with separately controllable *Pre-EQ attenuation*, *Post-EQ gain*, and downloadable biquad coefficients for each band.

For each channel, the pre-Bass Manager output PCM is first scaled down by the *Pre-EQ attenuation* setting for the corresponding channel. The attenuated output is then processed by a cascade of three EQ biquads specified by the (b_2, b_1, b_0, a_2, a_1) coefficients downloaded by the host controller before kickstart. The output of the cascade biquad stage is then gained up by the *Post-EQ gain* setting for the corresponding channel.

Note that the coefficients are specified in 3.21 format to allow for coefficient magnitudes of up to 8.0.

For its input $x(n)$ the output $y(n)$ of each EQ biquad filter is given by:

$$y(n) = x(n)*b_0 + x(n-1)*b_1 + x(n-2)*b_2 + y(n-1)*a_1 + y(n-2)*a_2$$

The *Pre-EQ input attenuation* applied before the EQ filters is a scale factor specified in usual 1.23 format. The *Post-EQ gain* applied after the EQ filter is a scale factor specified in 6.18 format to allow for up to 30 dB of gain, i.e. scale factor of 32.

Note: All biquad coefficients should be setup before kickstart and should not be modified during runtime.

• **Notes** •

SMART
Analog™



LittleDiode supplies new, hard to find or obsolete electronic components and semiconductors all over the world.

With over two million different components listed you are sure to find the part you need.

Feel free to visit us today at our online store:

LittleDiode.com

Looking forward to providing you with the best possible service.