

Application Note

PLL FILTER OPTIMIZATION FOR THE CS8415A, CS8420, AND CS8427

by Patrick Muyschondt and Stuart Dudley Dimond III

1. INTRODUCTION

The purpose of this application note is to give users of the CS8415A, CS8420, and CS8427 the information needed to optimize the performance of the Phase-Locked Loop for their requirements. Equations are provided to determine the filter values when driving the PLL from the AES Receiver or from the Serial Input Port.

The PLL design of the CS8415A, CS8420, and CS8427 is different from that of the CS8411/12 and CS8413/14. The filter values computed by the equations in this applications note are not applicable to the older devices. The sections on capacitor choice and board layout are applicable to both the old and the new parts.

2. PLL SYSTEM PARAMETERS

Figure 1 is a simplified diagram of the PLL in these parts. When the PLL is locked to an AES3 input stream, it is updated at each preamble in the AES3 stream. This occurs at twice the sampling frequency, F_S . When the PLL is locked to ILRCK, it is updated at F_S so that the duty cycle of the input doesn't affect jitter.

The following operating parameters of the PLL system are used in the filter calculations:

VCO Gain: $K_{VCO} = 4 \text{ MHz/V}$

Charge Pump Current: $I_{CP} = 300 \mu\text{A}$

Divider for AES3: $N = 128$

Divider for ILRCK: $N = 256$

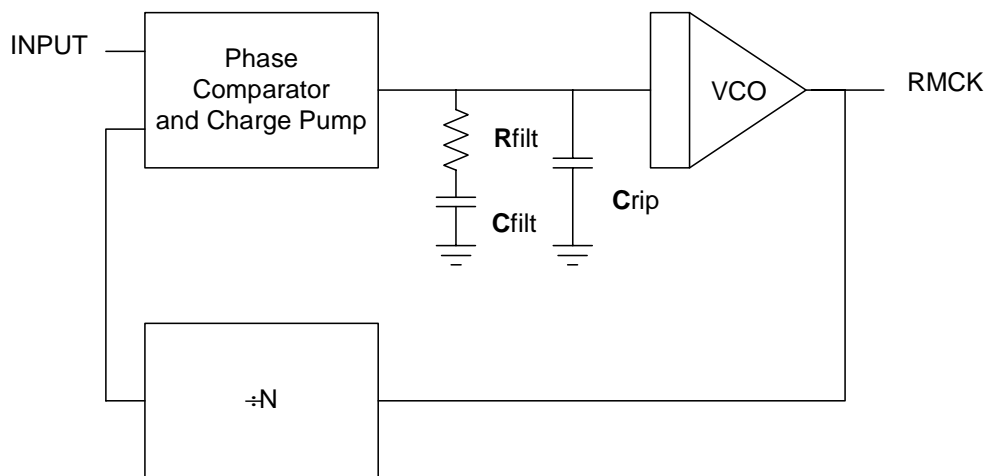

Figure 1. PLL Block Diagram

3. CAPACITOR CHOICE

Users frequently ask what capacitors to select for the PLL filter. Large or exotic film capacitors are not necessary. Their leads and the longer circuit board traces they require add undesirable inductance to the circuit. Surface mount ceramic capacitors are a good choice because their own inductance is low, and they can be mounted close to the FILT pin to minimize trace inductance. For C_{RIP} , a C0G or NPO dielectric is recommended, and for C_{FILT} , an X7R dielectric is preferred. Avoid capacitors with large temperature coefficients, or capacitors with high dielectric constants, that are sensitive to shock and vibration. These include the Z5U and Y5V dielectrics.

4. BOARD LAYOUT

Board layout and capacitor choice affect each other and determine the performance of the PLL. Figure 2 contains a suggested layout for the PLL filter components and for bypassing the analog supply voltage. The 0.1 μF bypass capacitor is in a 1206 form factor. R_{FILT} and the other three capacitors are in an 0805 form factor. The traces are on the top surface of the board with the IC so that there is no via inductance. The traces themselves are short to

minimize the inductance in the filter path. The VA+ and AGND traces extend back to their origin and are shown only in truncated form in the drawing.

5. PLL DESIGN EQUATIONS

The following equations provide a loop phase margin of 60°. This has been tested in the lab and found to be optimum. It gives the best performance in tolerating jitter on the incoming signal and maximizes DAC THD+N performance. Jitter transfer function peaking is 0.74 dB with the given equations (EQ1, EQ2, EQ3, EQ4, EQ6, and EQ8). The AES3 standard permits a maximum jitter peaking of 2 dB. The IEC60958 consumer specification allows a maximum of 3 dB of jitter peaking.

To use the design equations, first determine the minimum sample frequency that the PLL will have to lock to.

If you are using only the AES receiver use the equations in the AES3 design example.

If you are using the Input Serial Port or the Input Serial Port and the AES Receiver, use the equations in the Serial Input Port design example.

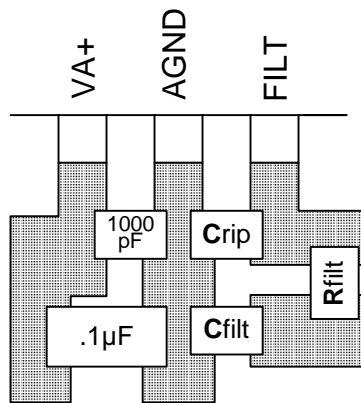

Figure 2. Recommended Layout Example

5.1 AES3 Design Example

Assume an application in which the incoming AES3 stream may have a sample rate from 32 kHz to 96 kHz. Using the minimum F_S of 32 kHz, the following can be computed:

$$f_{pole} = \frac{f_s}{2} = \frac{32000}{2} = 16000 \quad \text{EQ 1}$$

$$f_{lpbw} = \frac{f_s}{4} = \frac{32000}{4} = 8000 \quad \text{EQ 2}$$

$$f_{zero} = \frac{f_s}{80} = \frac{32000}{80} = 400 \quad \text{EQ 3}$$

With these values the filter components can then be determined.

$$\frac{2\pi \cdot N \cdot f_{lpbw}}{I_{CP} \cdot K_{VCO}} = R_{FILT} \quad \text{EQ 4}$$

$$\frac{2\pi \cdot 128 \cdot 8000}{300 \times 10^{-6} \cdot 4 \times 10^6} = 5362 \quad \text{EQ 5}$$

Select $R_{FILT} = 5100$ Ohms, the nearest standard 5% value.

$$\frac{1}{2\pi \cdot R_{FILT} \cdot f_{zero}} = C_{FILT} \quad \text{EQ 6}$$

$$\frac{1}{2\pi \cdot 5100 \cdot 400} = 0.078 \times 10^{-6} \quad \text{EQ 7}$$

Select $C_{FILT} = 0.082$ μF , the nearest standard value.

$$\frac{1}{2\pi \cdot R_{FILT} \cdot f_{pole}} = C_{RIP} \quad \text{EQ 8}$$

$$\frac{1}{2\pi \cdot 5100 \cdot 16000} = 1.95 \times 10^{-9} \quad \text{EQ 9}$$

Select $C_{RIP} = 2.2$ nF, the nearest standard value.

F_S	R_{FILT}	C_{FILT}	C_{RIP}
96 kHz	16k Ω	8.2 nF	220 pF
88.2 kHz	15k Ω	.01 F	270 pF
48 kHz	8.2k Ω	.033 μF	820 pF
44.1 kHz	7.5k Ω	.039 μF	1000 pF
32 kHz	5.1k Ω	.082 μF	2200 pF
24 kHz	3.9k Ω	.15 μF	3900 pF
16 kHz	2.7k Ω	.33 μF	8200 pF
8 kHz	1.3k Ω	1.2 μF	.033 μF

Table 1. Pre-computed values for operation from an AES3 input

5.2 Serial Input Port Design Example

Assume an application in which the Input Serial Port is driven at a sample rate of 32 kHz. The following can be computed:

$$f_{pole} = \frac{f_s}{4} = \frac{32000}{4} = 8000 \quad \text{EQ 10}$$

$$f_{lpbw} = \frac{f_s}{8} = \frac{32000}{8} = 4000 \quad \text{EQ 11}$$

$$f_{zero} = \frac{f_s}{160} = \frac{32000}{160} = 200 \quad \text{EQ 12}$$

With these values the filter components can then be determined.

$$\frac{2\pi \cdot N \cdot f_{lpbw}}{I_{CP} \cdot K_{VCO}} = R_{FILT} \quad \text{EQ 13}$$

$$\frac{2\pi \cdot 256 \cdot 4000}{300 \times 10^{-6} \cdot 4 \times 10^6} = 5362 \quad \text{EQ 14}$$

Select $R_{FILT} = 5100$ Ohms, the nearest standard 5% value.

$$\frac{1}{2\pi \cdot R_{FILT} \cdot f_{zero}} = C_{FILT} \quad \text{EQ 15}$$

$$\frac{1}{2\pi \cdot 5100 \cdot 200} = 0.156 \times 10^{-6} \quad \text{EQ 16}$$

Select $C_{FILT} = 0.15$ μ F, the nearest standard value.

$$\frac{1}{2\pi \cdot R_{FILT} \cdot f_{pole}} = C_{RIP} \quad \text{EQ 17}$$

$$\frac{1}{2\pi \cdot 5100 \cdot 8000} = 3.90 \times 10^{-9} \quad \text{EQ 18}$$

Select $C_{RIP} = 3.9$ nF, the nearest standard value.

F_s	R_{FILT}	C_{FILT}	C_{RIP}
96 kHz	16k Ω	.018 μ F	390 pF
88.2 kHz	15k Ω	.022 μ F	560 pF
48 kHz	8.2k Ω	.068 μ F	1800 pF
44.1 kHz	7.5k Ω	.082 μ F	2200 pF
32 kHz	5.1k Ω	.15 μ F	3900 pF
24 kHz	3.9k Ω	.27 μ F	6800 pF
16 kHz	2.7k Ω	.68 μ F	.015 μ F
8 kHz	1.3k Ω	2.7 μ F	.062 μ F

Table 2. Pre-computed values for operation from ILRCK or from ILRCK and AES3

• **Notes** •

SMART
Analog™



LittleDiode supplies new, hard to find or obsolete electronic components and semiconductors all over the world.

With over two million different components listed you are sure to find the part you need.

Feel free to visit us today at our online store:

LittleDiode.com

Looking forward to providing you with the best possible service.