

# DATA SHEET

Part No.	AN15866A
Package Code No.	QFH080-P-1420H

Maintenance/Discontinued includes following lifecycle stage.  
planned maintenance type  
maintenance type  
planned discontinued type  
discontinued type  
Please visit following URL about latest information.  
<http://www.semicon.panasonic.co.jp/en/>

## Contents

■ Features .....	3
■ Applications .....	3
■ Package .....	3
■ Application Circuit Example .....	4
■ Block Diagram .....	5
■ Pin Description .....	6
■ Absolute Maximum Ratings .....	7
■ Operating Supply Voltage Range .....	7

Maintenance/Discontinued includes four Product lifecycle stage.  
Discontinued  
planned maintenance type  
maintenance type  
planned discontinued type  
discontinued type  
Please visit following URL about latest information.  
<http://www.semicon.panasonic.co.jp/en/>

# AN15866A

## AV Switch IC

### ■ Features

- Video switch with I<sup>2</sup>C bus

### ■ Application

- Color TV

### ■ Package

- Quad 80-pin plastic package (QFH type)

Maintenance/Discontinued

Maintenance/Discontinued includes following four Product lifecycle stage.  
planned maintenance type  
maintenance type  
planned discontinued type  
discontinued type  
Please visit following URL about latest information.  
<http://www.semicon.panasonic.co.jp/en/>

Application Circuit Example

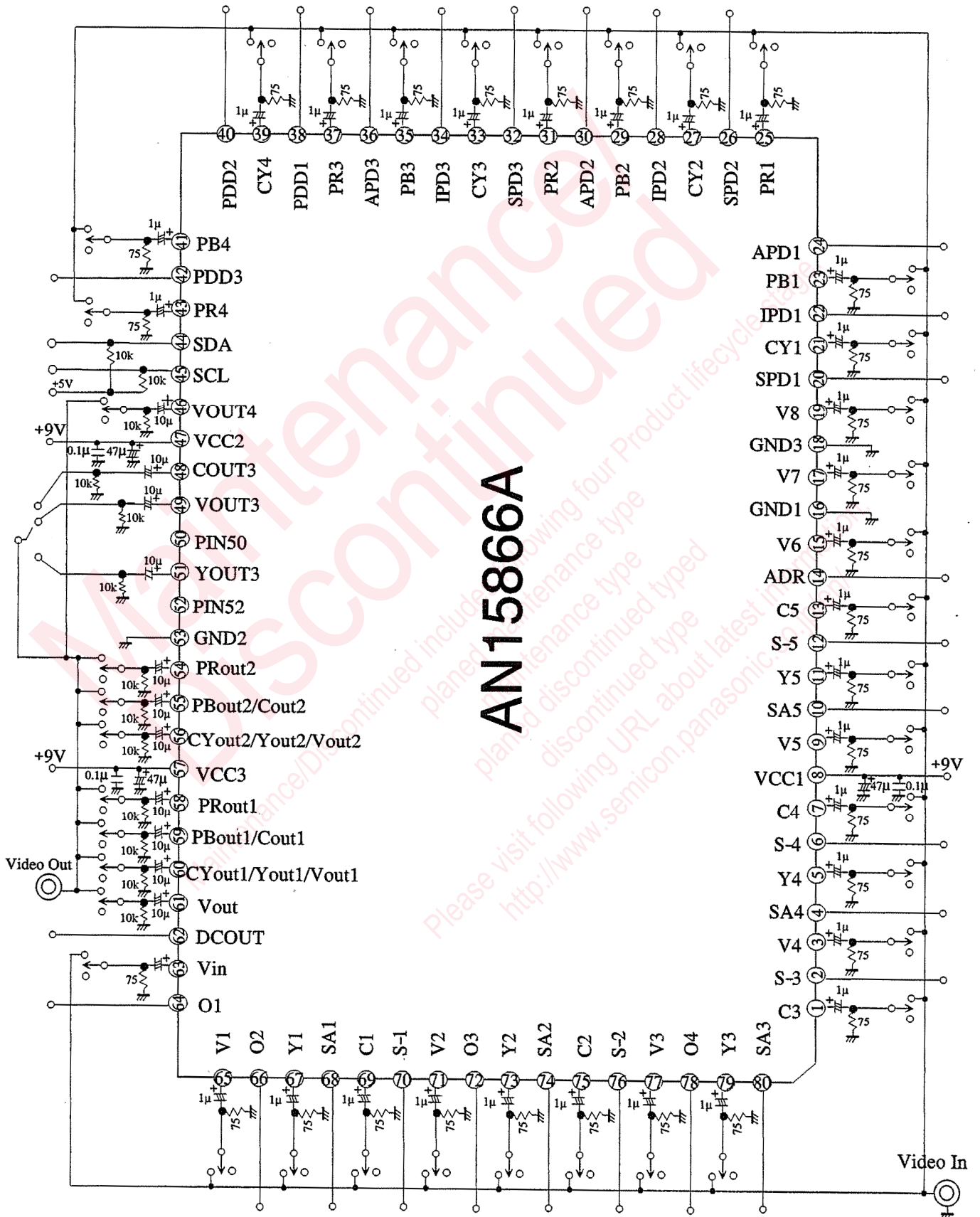

■ Block Diagram

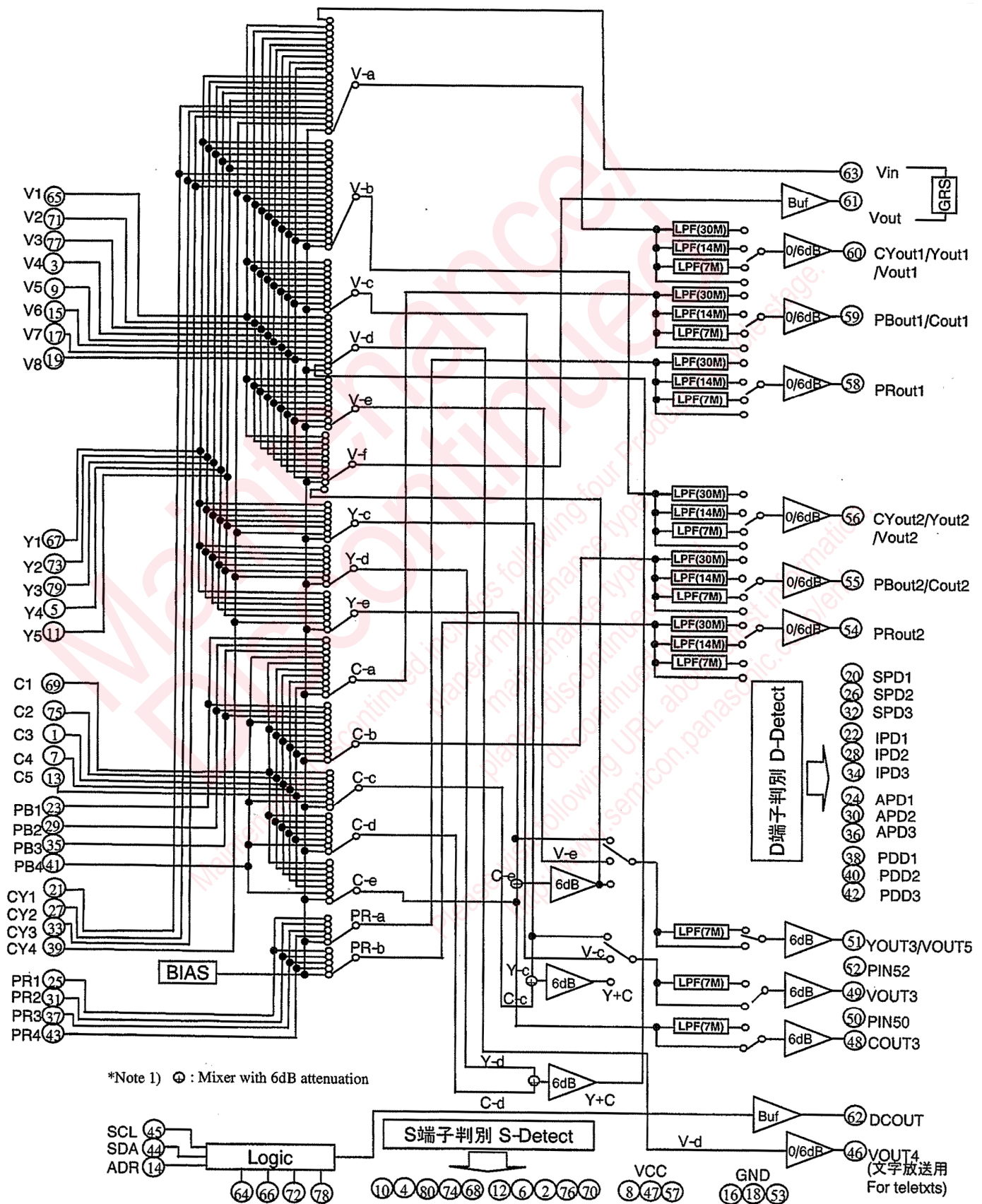

## ■ Pin Descriptions

Pin No.	Description	Pin No.	Description	Pin No.	Description
1	C3	28	IPD2	55	PB-out2 / C-out2
2	S3	29	PB2	56	CY-out2 / Y-out2 / V-out2
3	V4	30	APD2	57	V <sub>CC3</sub>
4	SA4	31	PR2	58	PR-out1
5	Y4	32	SPD3	59	PB-out1 / C-out1
6	S4	33	CY3	60	CY-out1 / Y-out1 / V-out1
7	C4	34	IPD3	61	V <sub>OUT</sub>
8	V <sub>CC1</sub>	35	PB3	62	DC-out
9	V5	36	APD3	63	V <sub>IN</sub>
10	SA5	37	PR3	64	O1
11	Y5	38	PDD1	65	V1
12	S5	39	CY4	66	O2
13	C5	40	PDD2	67	Y1
14	ADR	41	PB4	68	SA1
15	V6	42	PDD3	69	C1
16	GND1	43	PR4	70	S1
17	V7	44	SDA	71	V2
18	GND3	45	SCL	72	O3
19	V8	46	V-out4	73	Y2
20	SPD1	47	V <sub>CC2</sub>	74	SA2
21	CY1	48	C-out3	75	C2
22	IPD1	49	V-out3	76	S2
23	PB1	50	Pin 50	77	V3
24	APD1	51	Y-out3	78	O4
25	PR1	52	Pin 52	79	Y3
26	SPD2	53	GND2	80	SA3
27	CY2	54	PR-out2		

### ■ Absolute Maximum Ratings

No.	Parameter	Symbol	Rating	Unit	Note
1	Supply voltage	$V_{CC}$	12	V	—
2	Supply current	$I_{CC}$	—	mA	—
3	Power dissipation	$P_D$	725	mW	*1
4	Storage temperature	$T_{stg}$	-55 to +125	°C	*2
5	Operating ambient temperature	$T_{opr}$	-20 to +75	°C	*2
6	Operating ambient atmospheric pressure	$P_{opr}$	$1.013 \times 10^5 \pm 0.61 \times 10^5$	Pa	—
7	Operating constant gravity	$G_{opr}$	9 810	m/s <sup>2</sup>	—
8	Operating shock	$S_{opr}$	4 900	m/s <sup>2</sup>	—

Note) \*1: The above power dissipation shows the package power dissipation for this IC mounted on PCB at  $T_a = 75^\circ\text{C}$ .

\*2: Except for the storage temperature and operating ambient temperature, all ratings are for  $T_a = 25^\circ\text{C}$ .

### ■ Operating Supply Voltage Range

Parameter	Symbol	Range	Unit	Note
Operating Supply Voltage Range	$V_{CC}$	8.5 to 9.5	V	—

## Request for your special attention and precautions in using the technical information and semiconductors described in this book

- (1) If any of the products or technical information described in this book is to be exported or provided to non-residents, the laws and regulations of the exporting country, especially, those with regard to security export control, must be observed.
- (2) The technical information described in this book is intended only to show the main characteristics and application circuit examples of the products, and no license is granted under any intellectual property right or other right owned by our company or any other company. Therefore, no responsibility is assumed by our company as to the infringement upon any such right owned by any other company which may arise as a result of the use of technical information described in this book.
- (3) The products described in this book are intended to be used for standard applications or general electronic equipment (such as office equipment, communications equipment, measuring instruments and household appliances).  
Consult our sales staff in advance for information on the following applications:
  - Special applications (such as for airplanes, aerospace, automobiles, traffic control equipment, combustion equipment, life support systems and safety devices) in which exceptional quality and reliability are required, or if the failure or malfunction of the products may directly jeopardize life or harm the human body.
  - Any applications other than the standard applications intended.
- (4) The products and product specifications described in this book are subject to change without notice for modification and/or improvement. At the final stage of your design, purchasing, or use of the products, therefore, ask for the most up-to-date Product Standards in advance to make sure that the latest specifications satisfy your requirements.
- (5) When designing your equipment, comply with the range of absolute maximum rating and the guaranteed operating conditions (operating power supply voltage and operating environment etc.). Especially, please be careful not to exceed the range of absolute maximum rating on the transient state, such as power-on, power-off and mode-switching. Otherwise, we will not be liable for any defect which may arise later in your equipment.
  - Even when the products are used within the guaranteed values, take into the consideration of incidence of break down and failure mode, possible to occur to semiconductor products. Measures on the systems such as redundant design, arresting the spread of fire or preventing glitch are recommended in order to prevent physical injury, fire, social damages, for example, by using the products.
- (6) Comply with the instructions for use in order to prevent breakdown and characteristics change due to external factors (ESD, EOS, thermal stress and mechanical stress) at the time of handling, mounting or at customer's process. When using products for which damp-proof packing is required, satisfy the conditions, such as shelf life and the elapsed time since first opening the packages.
- (7) This book may be not reprinted or reproduced whether wholly or partially, without the prior written permission of Matsushita Electric Industrial Co., Ltd.



LittleDiode supplies new, hard to find or obsolete electronic components and semiconductors all over the world.

With over two million different components listed you are sure to find the part you need.

Feel free to visit us today at our online store:

[LittleDiode.com](http://LittleDiode.com)

Looking forward to providing you with the best possible service.