

AN1555N, AN1555NS

General-use Precision Timers

Overview

The AN1555N, and the AN1555NS are the integrated circuits designed for generating an accurate and stable timing pulse and timer time. They are widely applicable a monostable or unstable multivibrator, etc.

Features

- Timing control microseconds to hours
- Max frequency in oscillation mode 100kHz
- High stability vs. ambient temperature and supply voltage
- TTL compatible output
- 200mA sink or source output current capability
- Reset voltage : 1.4V typ

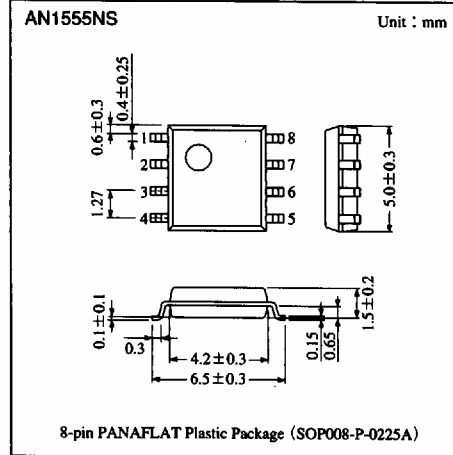
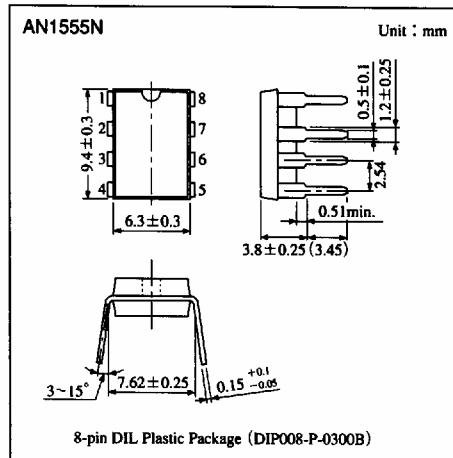

Block Diagram

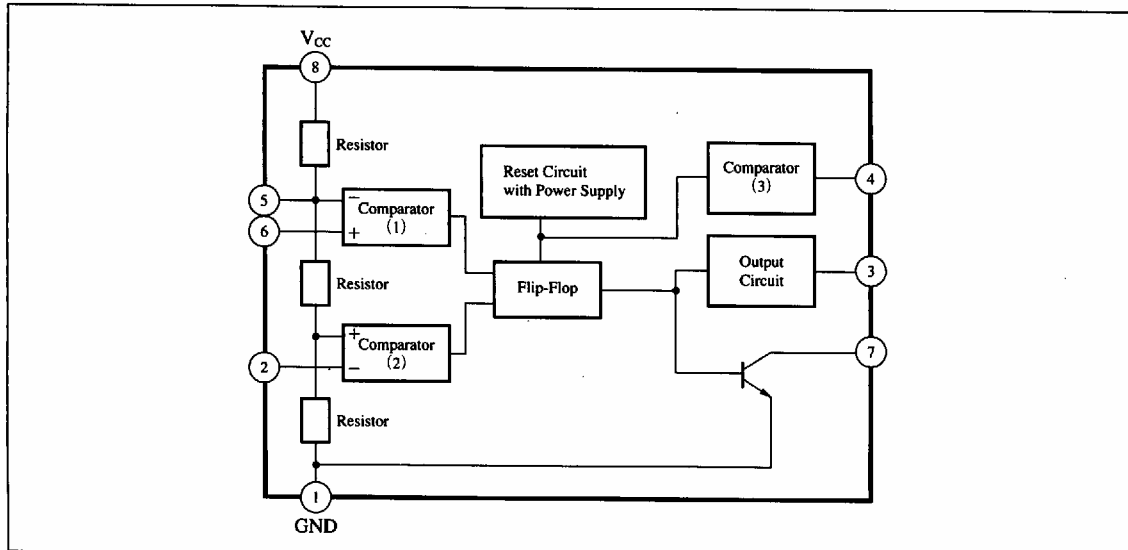

Pin Descriptions

Pin No.	Pin name
1	GND
2	Trigger
3	Output
4	Reset
5	Control voltage
6	Threshold
7	Discharge
8	V _{CC}

Absolute Maximum Ratings (Ta=25°C)

Parameter	Symbol	Rating	Unit
Supply voltage	V _{CC}	18	V
Power dissipation	AN1555N	625	mW
	AN1555NS	361	
Operating ambient temperature	T _{opr}	-20 to +75	°C
Storage temperature	T _{stg}	-55 to +125	°C

Electrical Characteristics (Ta=25°C)

Parameter	Symbol	Condition	min	typ	max	Unit
Circuit current	I _{tot}	V _{CC} =5V, R _L =∞, Output : L	—	5	7	mA
		V _{CC} =15V, R _L =∞, Output : L	—	8	12	mA
Threshold voltage	V _t	V _{CC} =5 to 15V	—	$\frac{2}{3}V_{CC}$	—	V
Threshold current	I _t	V _{CC} =5 to 15V	—	0.03	0.3	μA
Trigger voltage	V _(Trigger)	V _{CC} =5 to 15V	—	$\frac{1}{3}V_{CC}$	—	V
Trigger current	I _(Trigger)	V _{CC} =5 to 15V	—	0.1	0.5	μA
Reset voltage	V _(Reset)	V _{CC} =5 to 15V	—	1.4	2.0	V
Reset current	I _(Reset)	V _{CC} =5 to 15V	—	0.05	0.2	μA
Control voltage	V _(Cont.)	V _{CC} =5V	2.6	3.33	4.0	V
		V _{CC} =15V	9.0	10.0	11.0	V
Output voltage "L" level	V _{OL}	V _{CC} =5V, I _{SINK} : 5mA	—	0.05	0.2	V
		V _{CC} =5V, I _{SINK} : 8mA	—	0.08	0.25	V
		V _{CC} =15V, I _{SINK} : 10mA	—	0.05	0.2	V
		V _{CC} =15V, I _{SINK} : 50mA	—	0.2	0.5	V
		V _{CC} =15V, I _{SINK} : 100mA	—	0.5	2	V
		V _{CC} =15V, I _{SINK} : 200mA	—	2.5	—	V
Output voltage "H" level	V _{OH}	V _{CC} =5V, I _{SOURCE} : 100mA	2.8	3.3	—	V
		V _{CC} =15V, I _{SOURCE} : 100mA	12.8	13.3	—	V
Initial time interval error	Δt _E	Unstable oscillation R _A , R _B =1 to 100kΩ C=0.1μF	—	1.0	—	%
Time interval temperature regulation	Δt _T		—	50	—	ppm/°C
Time interval supply voltage regulation	Δt _V		—	0.1	—	%/V
Rise time	t _r	V _{CC} =5 to 15V	—	100	—	ns
Fall time	t _f		—	100	—	ns

Note) Operating Supply Voltage Range : V_{CC(opr)} = 4.5 to 16V

■ Characteristics Curve

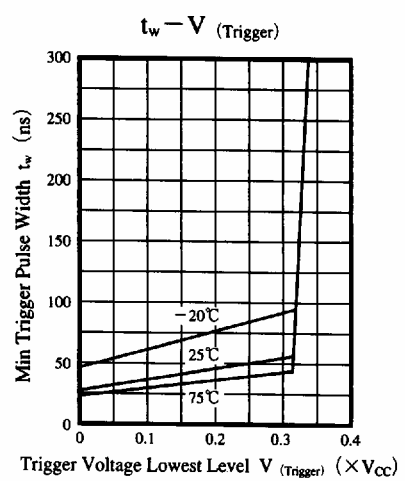
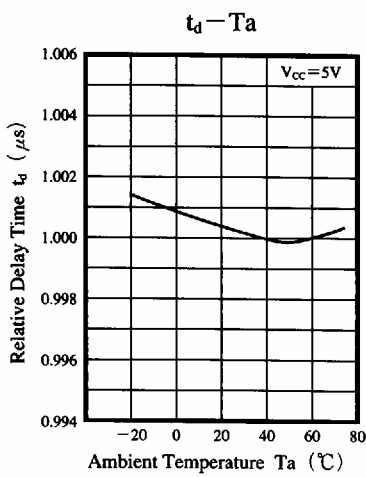
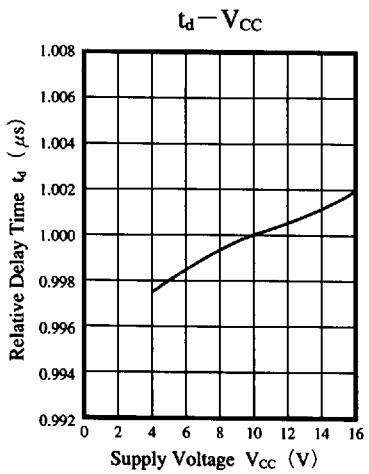
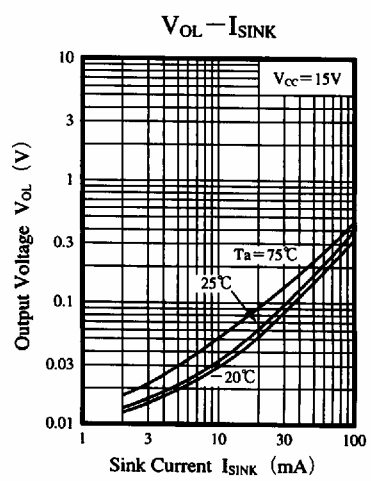
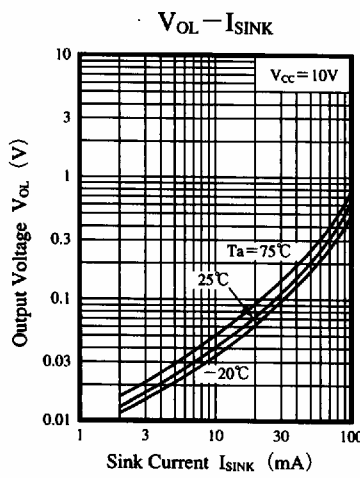
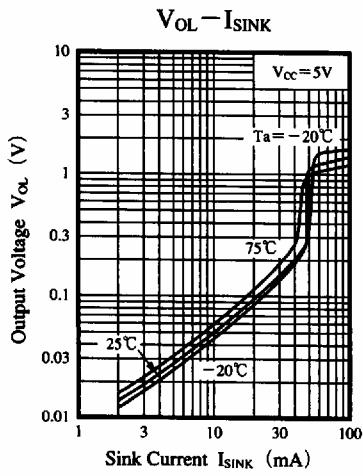
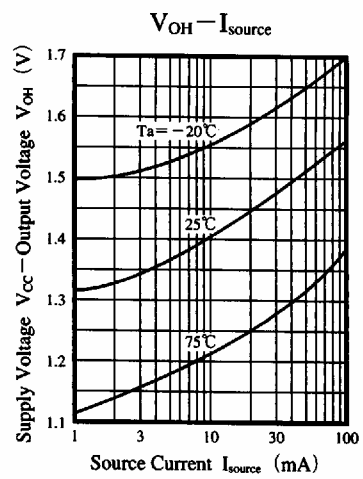
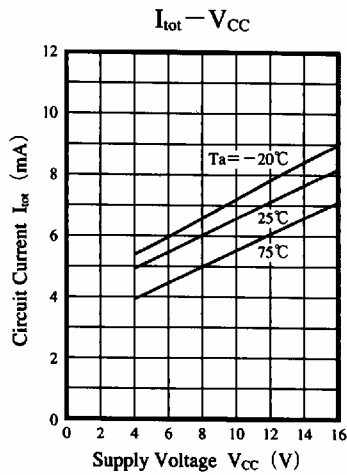
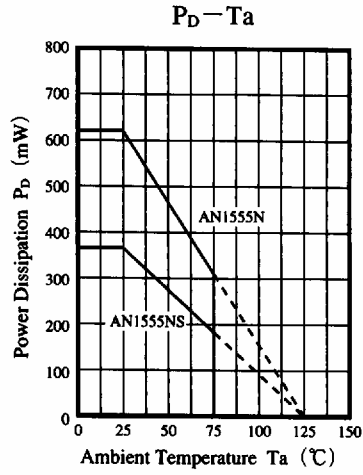

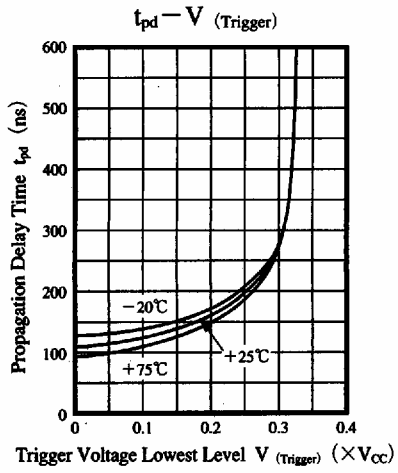

■ Application Circuit

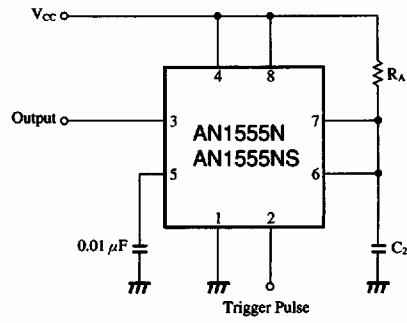

- Parts and measuring apparatus
- R_A : Metal film resistor
- C₂ : Polyester capacitor
- Output : Universal counter load 1kΩ

This datasheet has been downloaded from:

www.DatasheetCatalog.com

Datasheets for electronic components.



LittleDiode supplies new, hard to find or obsolete electronic components and semiconductors all over the world.

With over two million different components listed you are sure to find the part you need.

Feel free to visit us today at our online store:

LittleDiode.com

Looking forward to providing you with the best possible service.