

Advanced Mixed-Signal-Approach for Modern HVAC Systems

Introduction: The increasing complexity of modern HVAC-Control-Systems (Heating, Ventilating, Air-conditioning), requires more and more the capability of precise and quick System-Calibration during production. The following article will demonstrate a cost effective **Advanced Mixed-Signal Approach**.

include **Heater, AC, Inside Air, Outside Air** and **multiple Seat Temperature Inputs**. However, other criteria such as **Sunlight-Intensity** as well as the **Inside Humidity** will be additional parameters based on which the HVAC will be controlling the compartment's climate as well. This sensor matrix leads to the following generic block diagram:

The General HVAC Concept

The amount of analog inputs that need to be sensed by a modern HVAC feedback control system usually will

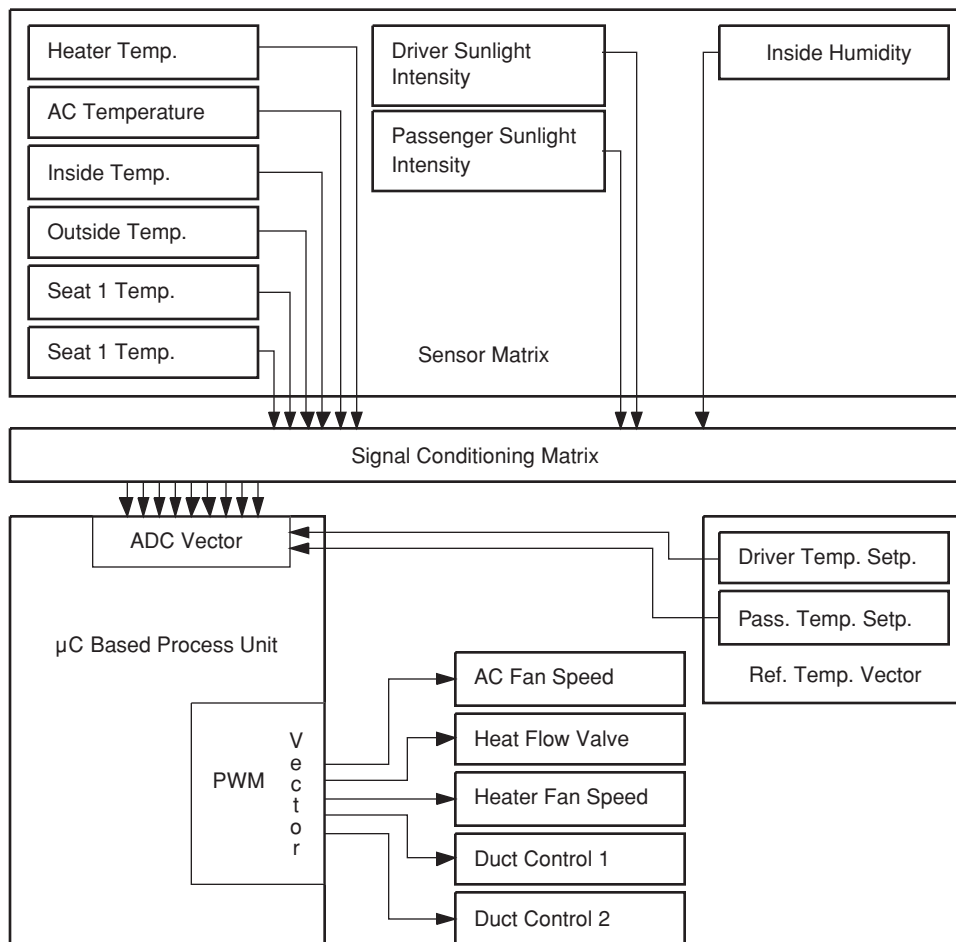

Figure 1. HVAC Block Diagram

Modern HVAC-Control-Systems need to sense several Analog Parameters in order to achieve a high level of passenger comfort

As pointed out in the above Block Diagram, the average compartment temperature is not any longer the **only physical** quantity to be monitored, but also **humidity** as well as the **sunlight intensity**. In case of this last one, what usually is being measured will be the **local light intensity** generated by the sun and therefore the amount of IR-Energy (**e.g. heat**) locally provided. This becomes especially an issue, when the individual comfort of driver and passengers deviate from each other depending whom is seated in the shadow or in the sun. Based on this difference of heat, the duct controls for driver and passenger need to be individually controlled.

On the other hand humidity becomes especially a key parameter in terms of safety when the passenger compartment air is almost saturated and it might condense at the inner surface of the windscreen. The HVAC's target will therefore be to cool down the compartment air **and** to make sure to condense the moisture **inside** of the AC **before** being supplied to the compartment.

Based on the above comments, figure 1 can be transformed into the following feedback control system block diagram:

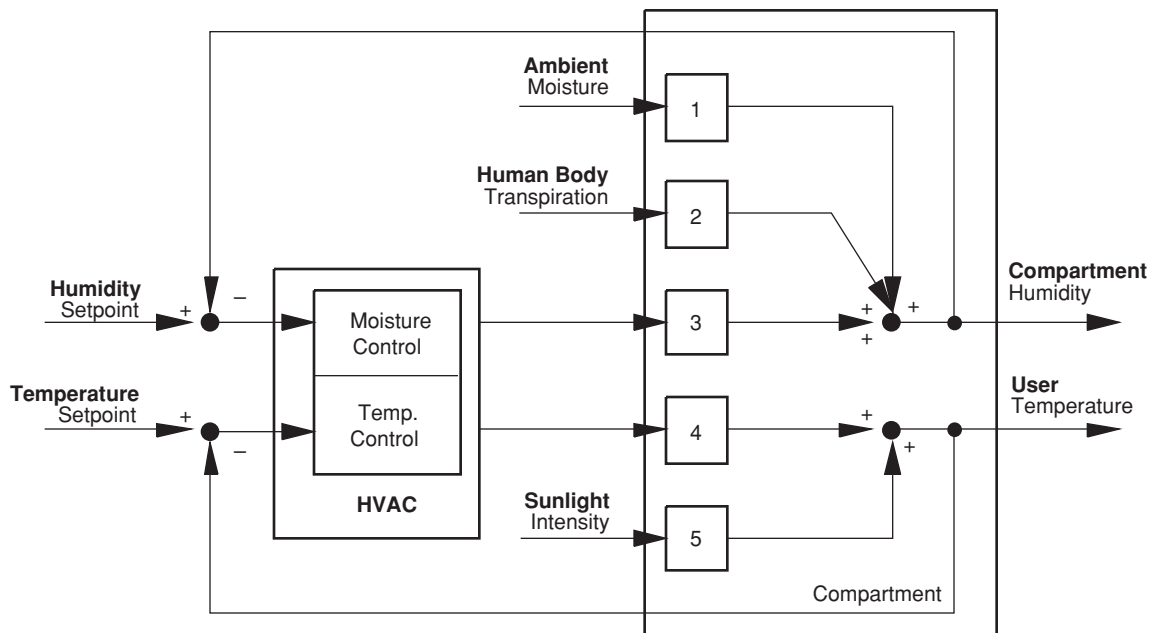

Figure 2. HVAC Feedback Control System

While Moisture and Temperature are the Physical Quantities that need to be dynamically controlled, the Sunlight Intensity becomes a **Distortion Parameter** within the Temperature Closed Loop that will be **additionally monitored**.

The System Level Challenge

With the above comments it becomes evident, that the whole Sensor Matrix needs to be calibrated properly in order to ensure a high level of comfort for any individual passenger. This will either mean to perform an **analog** signal conditioning of all matrix values (e.g. high precision) before providing them to the MCU or leave the

sensor's outputs as they are and perform a digital signal conditioning (e.g. high SW overhead). However, due to this high level of **complexity** as well as due to the **thermal behavior** of the Sensor Matrix itself, at least some of the Sensor Vector Outputs need to experience analog signal conditioning.

This indicates the following are needed as a minimum to make sure that:

- The complete **Temperature Sensor Vector** shows the same absolute values for a given reference temperature (e.g. **rel. temp. offset** = 0!)
- The **Photo Detector Vector** provides the same values for a determined light intensity (e.g. **relative sunlight intensity offset** = 0!) and that
- The **Humidity Sensor** shows a specific wanted value for a given moisture level (e.g. **absol. humidity offset** = 0!)

It is evident that the challenge will therefore be to perform the calibration of the **complete sensor matrix** within a **reasonable time**, no matter whether this is done in the analog or in the digital domain. The following concept will be based on a mixed-signal-approach that is meant to deal with the following targets:

- Implementation of a **high precision analog signal conditioning** solution that will keep the error vector generated by the sensor matrix (noise, offset, non-linearity, etc.) within an acceptable tolerance.
- Introduction of **programmability** in order to keep the required time for a whole calibration cycle (e.g. costs) as low as possible.

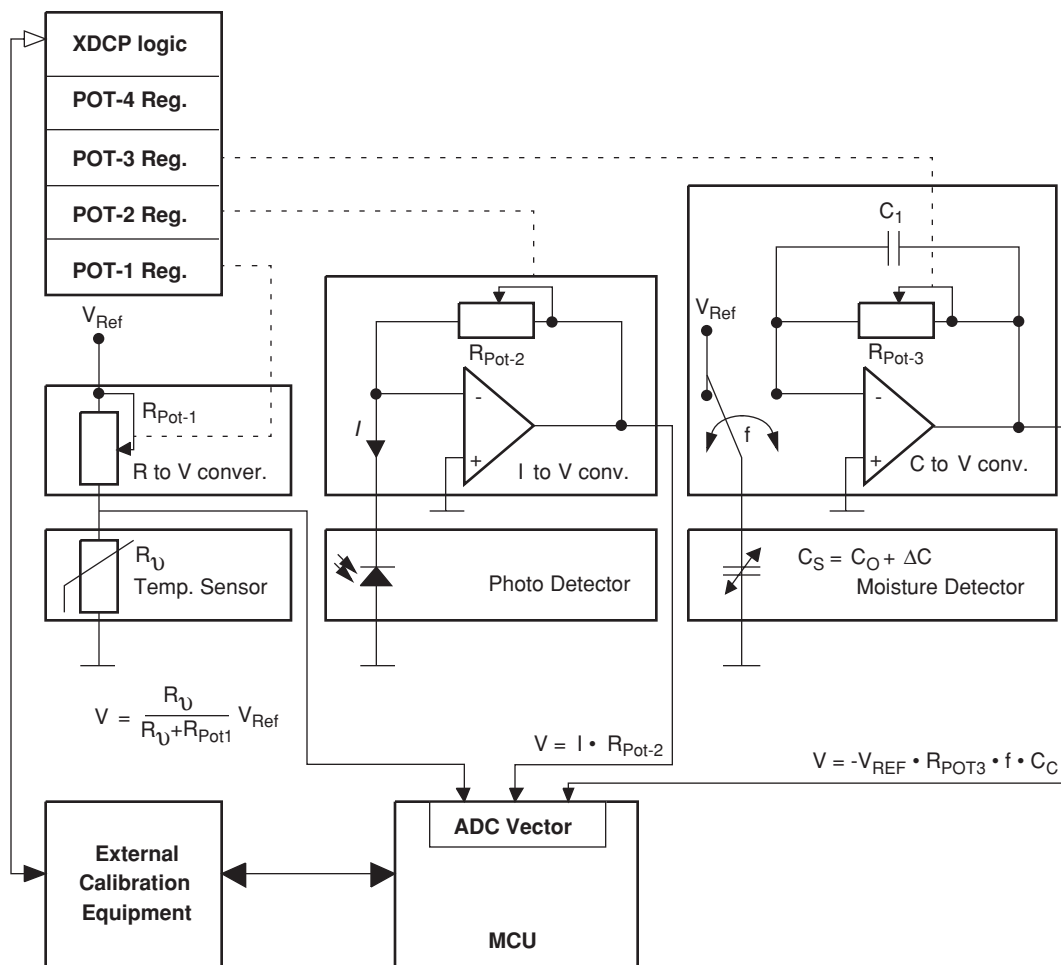

Figure 3. Mixed Signal Approach for a Generic HVAC System

Analog Signals of Temperature, Light and Moisture Detectors are conditioned in the analog domain, while their calibration will be MCU supported.

The first XDCP (Xicor Digitally Controlled Potentiometer) **Pot-1** acts as a resistor-to-voltage converter within a voltage divider circuit. Its output might be passed through an additional amplifier circuit, which will require another variable resistor in order to tune the gain.

The second XDCP **Pot-2** acts as a current-to-voltage converter in combination with an operational amplifier circuit. Using a DC-Voltage-source between the photodiode and ground might expand the bandwidth of this circuit.

The last circuit with the moisture sensitivity sensor is based on the so-called **Switched-Capacitor-Technique**. In that case “**f**” represents the frequency, which the switch will be driven with. This might either be generated by a switch-mode logic or directly coming from the MCU. C_C represents an average value between C_S and C_1 . As the moisture to be sensed starts to change, the capacitor’s dielectric constant and therefore its capacitance will change as well. Based on the very well known effect “ $C_S = Q/V$ ”, **Pot-3** will act – similar as Pot-2 – within the amplifier circuit as a Capacitance to Voltage converter.

The Benefits

Although the above circuit had been built up with standard blocks that need further accommodation within a real HVAC system, it evidently points out the necessity of **Relative-Offset** compensation when talking about a specific Sensor-Vector. Each sensor bears – depending on the way it is being used – an Absolute and a Relative Offset. The above used Photo Detector might, for example, exhibit an absolute offset if used (not in the above circuit) with an additional voltage source.

However, if the number of photo detectors within a matrix becomes bigger than one, each light sensor will also exhibit an additional relative offset as compared to the other once. In such a case the main concern will be at least to reduce the relative offset within the analog domain, before the individual vector values are being applied to the ADC-Vector.

Since these principles are applicable to all other sensor vectors (in this case the temp. and moisture sensor

vector), it is very clear that a pure analog signal conditioning approach will require an extensive amount of time for the complete system’s calibration. On the other hand, a pure digital approach will most probably require the use of:

- Additional digital peripherals like an extensive memory array (in order to store all sensor characteristic data)
- A bigger and faster MCU (in order to administrate all activities in the fastest possible way)
- A DSP (in order to calculate all required values)

This amount of overhead might not be justified in terms of the return on investment within these types of applications. Using this advanced mixed-signal approach will help to keep the direct (high-end components, SW) and indirect costs (system calibration, assembly) at an acceptable level. With the above-presented advanced mixed-signal solution, all sensor vectors can be tuned to a predetermined value **at a high precision analog level** through a serial interface in an **automated way**.

The Xicor Approach

The key to successful cost reduction will be the use of Xicor’s XDCPs. For the above circuit two quad XDCPs and one single XDPC will be enough to cover all variable analog parameters. The above mentioned application could be built up with two **X9259-XDCPs** (= 2 x 4 x 256 Steps/Pot) and one **X9279-XDCP** (= 1 x 256 Steps/Pot). Both are fully I²C-addressable (400 kHz), and include an additional on-chip E²PROM register set.

Since Xicor’s XDCPs will automatically recall during power-up the stored wiper positions in these registers, there will be no further need for digital communication between any XDCP and a MCU, as soon as the calibration had been successfully completed. Cost reduction will therefore be achieved by eliminating any manual adjustment performed up-to now and by keeping the costs for additional peripheral devices within a reasonable range, with the highest possible level of analog accuracy.



LittleDiode supplies new, hard to find or obsolete electronic components and semiconductors all over the world.

With over two million different components listed you are sure to find the part you need.

Feel free to visit us today at our online store:

LittleDiode.com

Looking forward to providing you with the best possible service.