



**VIPower: LOW COST UNIVERSAL INPUT SMPS  
FOR DIGITAL SET-TOP BOX BASED ON VIPer50**

---

F. Gennaro

**ABSTRACT**

In this paper the design of a low cost power supply for digital Set Top Box (STB) is introduced. The converter uses VIPower VIPer50 in Flyback configuration with secondary isolated output regulation and provides 6 isolated outputs. The power supply is suitable for universal input range as required by such a consumer application.

**INTRODUCTION**

Set-top boxes (STB) are commonly used for connecting to satellite and cable TV providers and to play TV video games. These consumer devices, typically placed on top of TV sets, interact with the signal processing circuits of television and VCR. It represents an optimal integration between information and entertainment, also providing in-home Internet access, interactive information, streaming video and electronic programming through a traditional television set and a cable or a telephone line.

Thanks to such features, worldwide digital set-top box sales, including cable, satellite and terrestrial platforms, are projected to grow from 28 million units in 2000, to 45 million units in 2004.

Several circuits make up a STB, such as digital circuitry, SCART port, LNB regulator and tuner supply. Single on-board power supply is required to feed all these circuits, providing low cost and worldwide mains usage. The major concern is cost since STB is going to become a widespread consumer product. In this paper the design of a low cost power supply for digital Set Top Box is introduced. The converter uses VIPower VIPer50 in Flyback configuration with output regulation by means of optocoupler and TL431. It has been designed for wide range input voltage, i.e.  $85\text{-}265V_{ac}$ , to supply 20W output power on six outputs.

The VIPer is a family of monolithic smart power that makes easier size and cost savings for multi output power supplies, providing integrated start-up and protection circuits such as current limiting, thermal shutdown and over/under voltage detection.

**1. APPLICATION DESCRIPTION AND DESIGN**

The proposed power supply has been designed referenced to the specifications listed in Table 1. The switching frequency has been selected considering both transformer size and EMI behavior; in fact the harmonics to be evaluated will start from the third one since the frequency range is 150kHz-30MHz for conducted emissions according to EN55022 standard.

The target efficiency is 70% higher with a maximum duty cycle of 45% at minimum input voltage in discontinuous conduction mode.

## AN1539 - APPLICATION NOTE

---

The regulation is performed on the lowest voltage output, i.e. 2.5V, and cross regulation is achieved by means of a simple circuit and optimized transformer coupling. All the outputs are directly connected to the load, except for the 3.3V. In fact, this output is provided using a standard linear voltage regulator on the 5V output in order to assure high accuracy.

The input EMI filter consists in a Pi-filter for both differential and common mode emissions. In order to improve the efficiency, a Transil clamper is used instead of a standard RCD clamper that would dissipate power at any operating condition.

The VIPer makes power supply design easier considering start-up, sensing and no-load issues, improving the overall efficiency and simplifying the circuit. The short circuit protection is provided with hiccup mode for every output with the exception of 2.5V and 5V outputs that need a simple auxiliary circuit. A leading edge blanking circuit (Q1, C16, R14) that masks voltage spikes at turn off is also used to improve short circuit behavior. A zener diode can be connected on COMP pin in order to clamp the voltage on such a pin and thus limiting the maximum output power. However an input 5\*20 fuse is used to protect the system against catastrophic failures. The input section also has an NTC to limit the inrush current of the bulk capacitor during the start-up of the power supply.

The switching frequency is set by R3 and C4 according to the diagram given in the datasheet. C3 is the VIPer supply capacitor connected on  $V_{DD}$  pin and an RC network (R4, C6) is also connected on  $V_{DD}$  giving extra protection against lightning and surge spikes.

Moreover, the VIPer has a built-in burst mode circuit that allows cycle skipping under low load condition, improving stand-by performance.

**Table 1:** SMPS specifications

<b>Input voltage</b>	85-265 $V_{ac}$
<b>Output power</b>	16W
<b>Outputs</b>	6
<b>Out<sub>1</sub></b>	2.5V at 800mA, $P_1=2W$ , 2%
<b>Out<sub>2</sub></b>	3.3V at 600mA, $P_2=1.98W$ , 2%
<b>Out<sub>3</sub></b>	5V at 350mA, $P_3=1.75W$ , 2%
<b>Out<sub>4</sub></b>	12V at 100mA, $P_4=1.2W$ , 5%
<b>Out<sub>5</sub></b>	22V at 400mA, $P_5=8.8W$ , 5%
<b>Out<sub>6</sub></b>	30V at 10mA, $P_6=0.06W$ , 10%
<b>Switching frequency</b>	70 kHz

### 1.1 TRANSFORMER CONSIDERATIONS

In multi-output isolated converters the transformer is of primary concern since output voltage regulation and cross regulation are based on winding coupling.

In the considered application the Flyback transformer has 7 windings, since one winding is dedicated to supply the VIPer, as listed in Table 2. Winding arrangement is shown in Figure 1, while transformer pin-

out is shown in Figure 2. The reflected voltage has been set to 70V, in order to have room for leakage inductance spike. The transformer is a slot type manufactured by OREGA. In this demo board an ETD29 core has been used, allowing further increase of the output power, but a smaller core, e.g. ETD20, is suitable for the considered power level.

Table 2: Transformer features

Core	ETD29	Thomson B2
AI	180 nH	
Primary inductance	832uH $\pm$ 10%	68 turns
Leakage inductance	16uH (typical)	
<b>Windings specs</b>		
Output 2.5V		2 turns
Output 5V		4 turns
Output 12V		8 turns
Output 22V		7 turns
Output 30V		20 turns
Aux		9 turns

Figure 1: Transformer layout

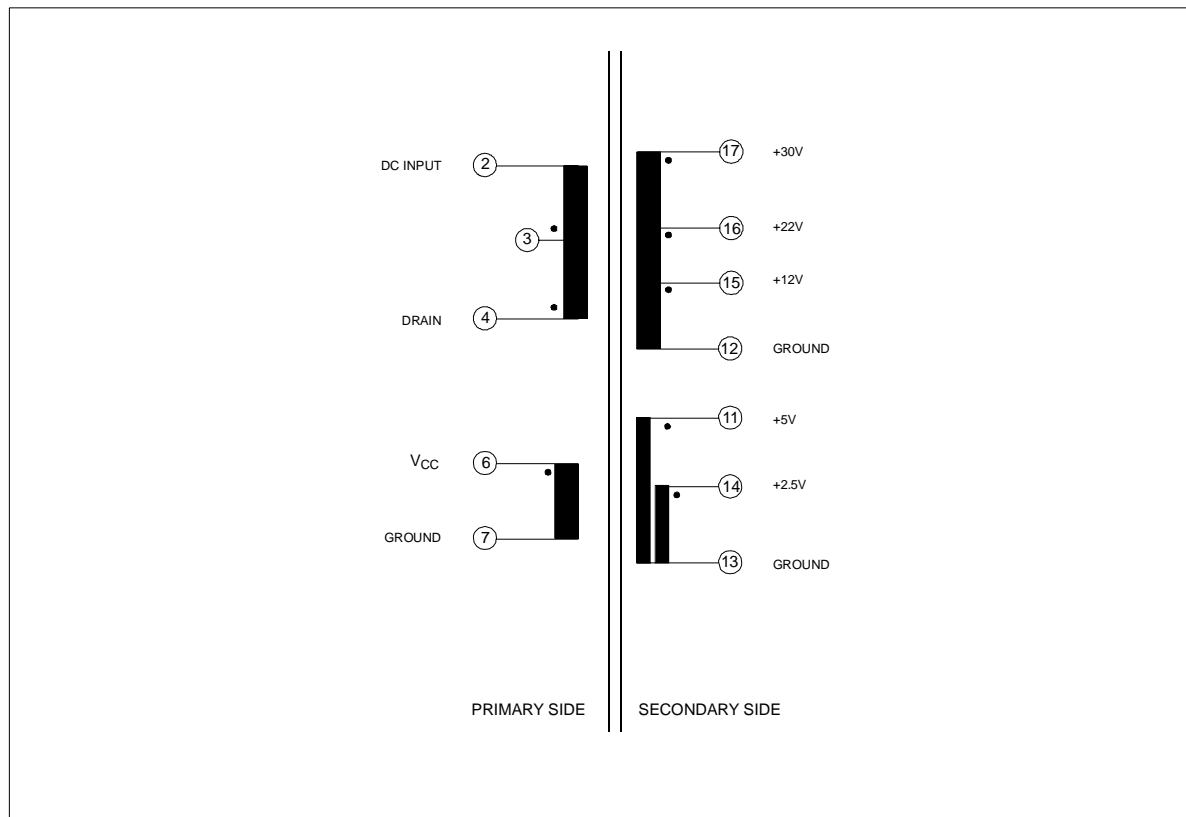
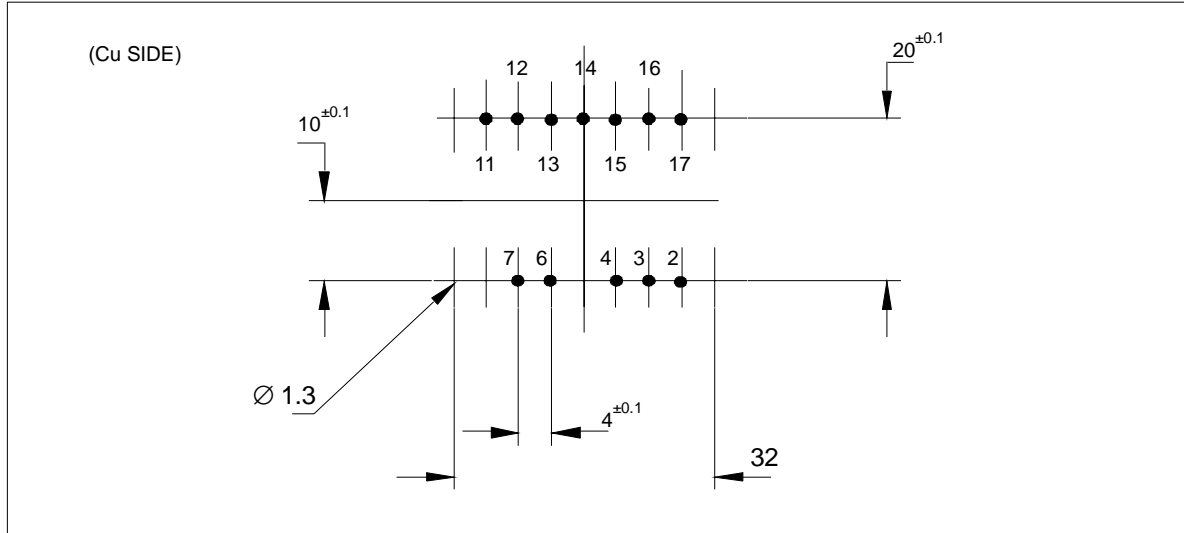

Figure 2: Transformer pin out



The design of the transformer windings has been done according to (1). Once the primary inductance value and turns ratio  $N_p/N_{OL}$ , between primary and lowest voltage output, is selected,  $V_t$  parameter, volt-per-turn value, can be calculated. Then, all the other turn values are given by (2).

$$V_t = \frac{V_{OL} + V_D}{N_{OL}} \quad (1)$$

$$N_{Ok} = \frac{V_{Ok} + V_D}{V_t} \quad (2)$$

WHERE  $V_D$  is the diode forward voltage drop, i.e. 0.7V for PN diodes and 0.4V for Schottky diodes, k is related to the  $k^{th}$  output. Either kind of diodes, fast recovery PN or Schottky barrier, are used in order to adjust the related output voltage.

### 1.2 OUTPUT RECTIFIER DIODES SELECTION

The selection of the output rectifier diodes has been done considering reverse voltage and forward current rating, as defined in (3) and (4).

$$V_{kmax} = V_{Ok} + \left( V_{DCmax} \cdot \frac{N_{Ok}}{N_p} \right) \quad (3)$$

$$I_{kmax} = \frac{2 \cdot I_{Okmax}}{1 - D_{max}} \quad (4)$$

where  $V_o$  is the considered output voltage,  $V_{DCmax}$  is maximum input DC voltage,  $N_o$  is the number of turns and  $N_p$  is the primary turns.

### 1.3 OUTPUT FILTER CAPACITORS

Output capacitors values depend on the output current, voltage ripple and switching frequency according to (5).

$$C_{Ok} = \frac{I_{Ok\ max}}{f_{sw} \cdot V_{Ok\_ripple}} \quad (5)$$

### 1.4 VOLTAGE FEEDBACK

The voltage feedback is provided using a TL431 on the 2.5V output and an optocoupler. The voltage at the collector of the optocoupler sets the peak drain current of the VIPer device. Feedback compensation circuit is connected across TL431 cathode and reference pin.

For a given current sunk from COMP pin of the VIPer in order to perform proper voltage regulation, the LED current is calculated considering the optocoupler transfer ratio  $C_{trr}$  of 200%, then the limiting resistor of the LED current  $R_{lim}$  can be calculated according to (6).

$$R_{lim} = \frac{[5V - (V + V_{LED})]}{I_{LED}} \quad (6)$$

In order to improve the regulation of 5V output, the output voltage sensing is split using two resistors, as shown in Figure 3. In fact, this output is usually connected to voltage sensitive circuits such as microprocessors and other low voltage logic devices.

Figure 3: Circuit schematic

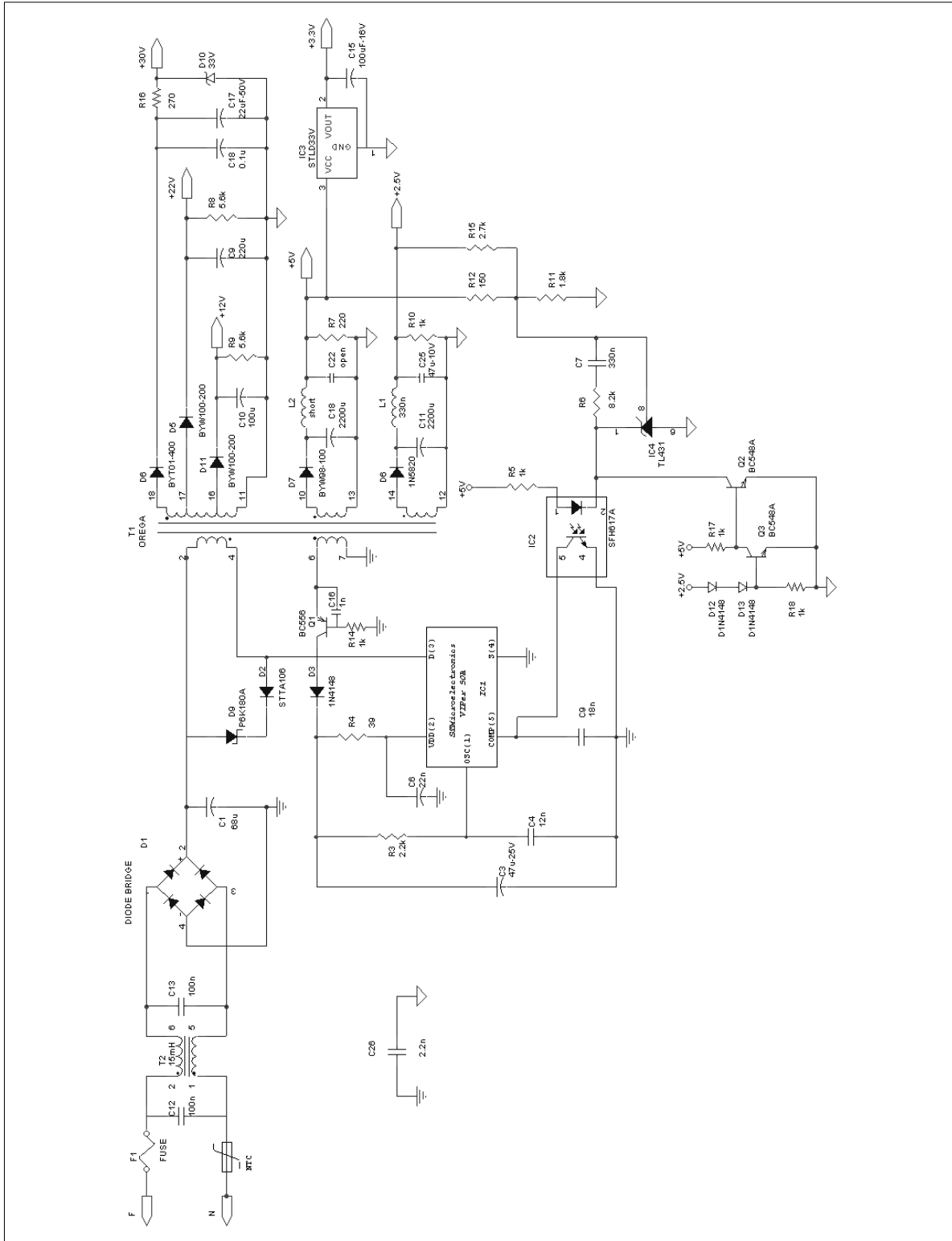

**Table 3:** Component list

Symbol	Value	Note
F <sub>1</sub>	T2AL250V	Fuse 5x20
R <sub>3</sub>	2.2 kΩ	
R <sub>4</sub>	39 kΩ	
R <sub>5</sub>	1 kΩ	
R <sub>6</sub>	8.2 kΩ	
R <sub>7</sub>	220 Ω	
R <sub>8</sub>	5.6 kΩ	
R <sub>9</sub>	5.6 kΩ	
R <sub>10</sub>	1 kΩ	
R <sub>11</sub>	1.8 kΩ	
R <sub>12</sub>	150 Ω	
R <sub>14</sub>	1 kΩ	
R <sub>15</sub>	2.7 kΩ	
R <sub>16</sub>	270 Ω	
R <sub>17</sub>	1 kΩ	
R <sub>18</sub>	1 kΩ	
C <sub>1</sub>	68uF – 400V	
C <sub>3</sub>	47uF – 25V	
C <sub>4</sub>	12 nF – 25V	
C <sub>6</sub>	22 nF – 25V	
C <sub>7</sub>	330 nF – 25V	
C <sub>8</sub>	2200 uF – 25V	
C <sub>9</sub>	220 uF – 50V	
C <sub>10</sub>	100 uF – 25V	
C <sub>11</sub>	2200 uF – 25V	
C <sub>12</sub>	100 nF – 250V	X2 capacitor

## AN1539 - APPLICATION NOTE

C <sub>13</sub>	100 nF – 250V	X2 capacitor
C <sub>15</sub>	100 uF – 10V	
C <sub>16</sub>	1 nF – 25V	
C <sub>17</sub>	22 uF – 50V	
C <sub>18</sub>	100nF	
C <sub>25</sub>	47 uF – 10V	
C <sub>26</sub>	2.2nF	
D <sub>1</sub>	DF06M	1A – 600V
D <sub>2</sub>	STTH106	
D <sub>3</sub>	1N4148	<b>STMicroelectronics</b>
D <sub>4</sub>	BYT01-400	<b>STMicroelectronics</b>
D <sub>5</sub>	BYW100-200	<b>STMicroelectronics</b>
D <sub>6</sub>	1N5820	<b>STMicroelectronics</b>
D <sub>7</sub>	BYW98-100	<b>STMicroelectronics</b>
D <sub>9</sub>	P6K180A	<b>STMicroelectronics</b>
D <sub>10</sub>	1N4752A - 33V	
D <sub>11</sub>	BYW100-200	
D <sub>12</sub>	1N4148	
D <sub>13</sub>	1N4148	
Q <sub>1</sub>	BC556	
Q <sub>2</sub>	BC548A	
Q <sub>3</sub>	BC548A	
L <sub>1</sub>	330 nH	
T <sub>1</sub>	OREGA	
T <sub>2</sub>	15 mH	S+M B82732
IC <sub>1</sub>	VIPer50(022Y)	<b>STMicroelectronics</b>
IC <sub>2</sub>	SFH617A	
IC <sub>3</sub>	STLD33V	<b>STMicroelectronics</b>
IC <sub>4</sub>	TL431	<b>STMicroelectronics</b>

Figure 4: PCB layout (not in scale)

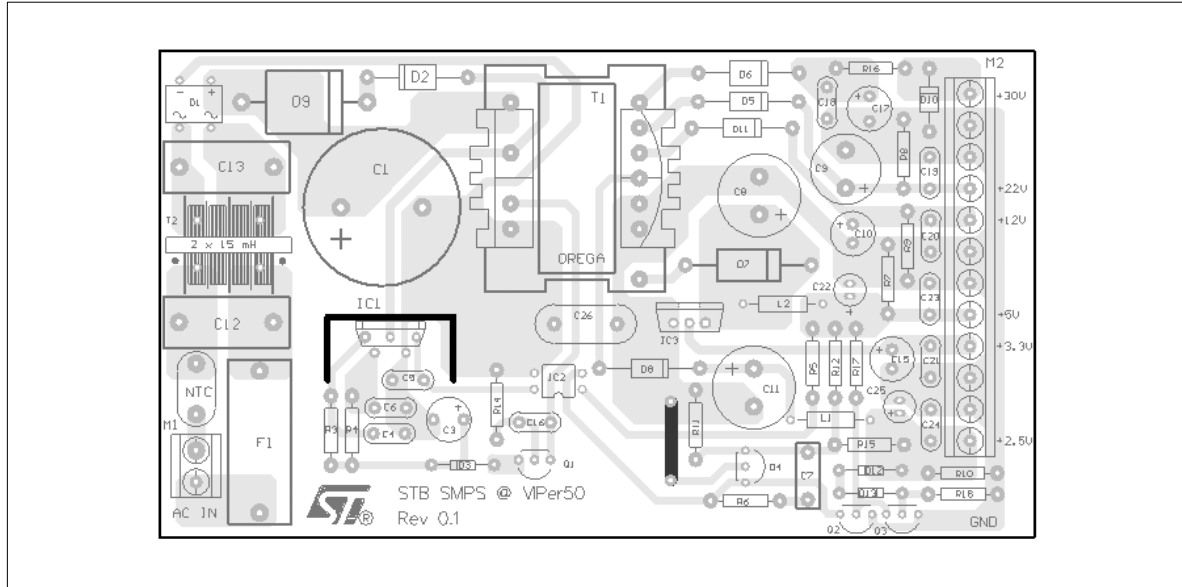

The board has been developed on a 135X75 Cu single side 70mm FR-4 frame.

## 2. LAYOUT RECOMMENDATION

Since EMI issues are strongly related to layout, a basic rule has to be taken into account in high current path routing, i.e. the current loop area has to be minimized.

If a heatsink is used it has to be connected to ground too, in order to reduce common mode emissions since it is close to the floating drain tab.

One more consideration has to be done regarding the control ground connection: in fact in order to avoid any noise interference on VIPer logic pin the control ground has to be separated from power ground. This results in a dedicated track for ground connection of C3, C4, C6, C9 and IC2 collector.

## 3. EXPERIMENTAL RESULTS

### 3.1 PERFORMANCE AND TYPICAL WAVEFORMS

In this section the performances of the power supply in terms of voltage regulation, power consumption as well as typical waveforms are given.

In Table 4 and 5 the main experimental results are listed. The converter features an excellent voltage regulation as the input voltage changes, with low power consumption at no load and efficiency 70% higher at full load. In Figure 5 and 6 the drain voltage  $V_{DS}$  at 110V<sub>ac</sub> and 220V<sub>ac</sub> at no-load and full load is shown, respectively. In Figure 7  $V_{DS}$  during the first cycles at start up is shown: the voltage never goes higher than 600V, below the breakdown voltage. Start up transient is shown in Figure 8 at 110V<sub>ac</sub> and 220V<sub>ac</sub> respectively. Thanks to the internal current generator, that provides constant 2mA current, the

## AN1539 - APPLICATION NOTE

start up time is independent of the input voltage and depends only on the  $V_{DD}$  capacitor.

The voltage ripple at full load in the main outputs, i.e. 2.5V, 5V, 12V and 22V, is shown in Figure 9.

**Table 4:** Voltage regulation and power dissipation at no-load,  $T_{amb}=30^{\circ}\text{C}$

$V_{inac}$ ( $V_{rms}$ )	$P_{in}$ (W)	$V_{out1}$ (V)	$V_{out2}$ (V)	$V_{out3}$ (V)	$V_{out4}$ (V)	$V_{out5}$ (V)	$V_{out6}$ (V)
85	1	2.53	3.28	5.41	12.91	24.6	32.5
115	1.1	2.53	3.28	5.41	12.92	24.7	32.5
230	1.4	2.53	3.28	5.40	12.90	24.6	32.5
265	1.45	2.53	3.28	5.40	12.89	24.6	32.5

**Table 5:** Voltage regulation and efficiency at full-load,  $T_{amb}=30^{\circ}\text{C}$ .

$V_{inac}$ ( $V_{rms}$ )	$\eta$	$V_{out1}$ (V)	$V_{out2}$ (V)	$V_{out3}$ (V)	$V_{out4}$ (V)	$V_{out5}$ (V)	$V_{out6}$ (V)
85	71%	2.49	3.24	5.18	12.05	22.2	32.9
115	73%	2.49	3.24	5.19	12.05	22.2	32.8
230	74%	2.50	3.24	5.18	12.05	22.1	32.8
265	73%	2.49	3.24	5.19	12.05	22.1	32.9

**Figure 5:**  $V_{DS}$  at no load at  $110V_{ac}$  and  $220V_{ac}$

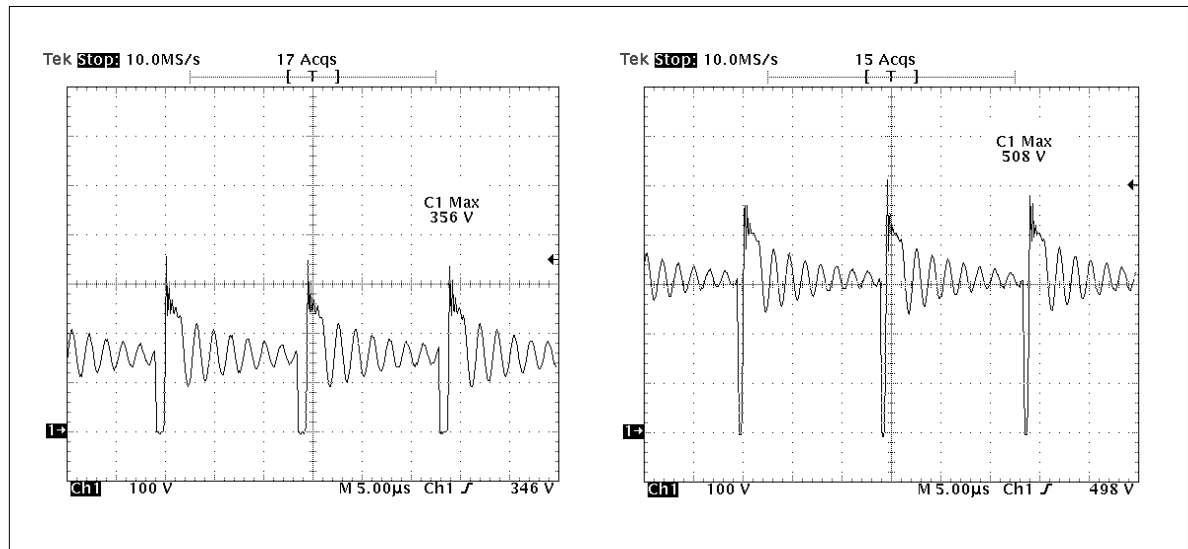

Figure 6:  $V_{DS}$  at full load at 110V<sub>ac</sub> and 220V<sub>ac</sub>

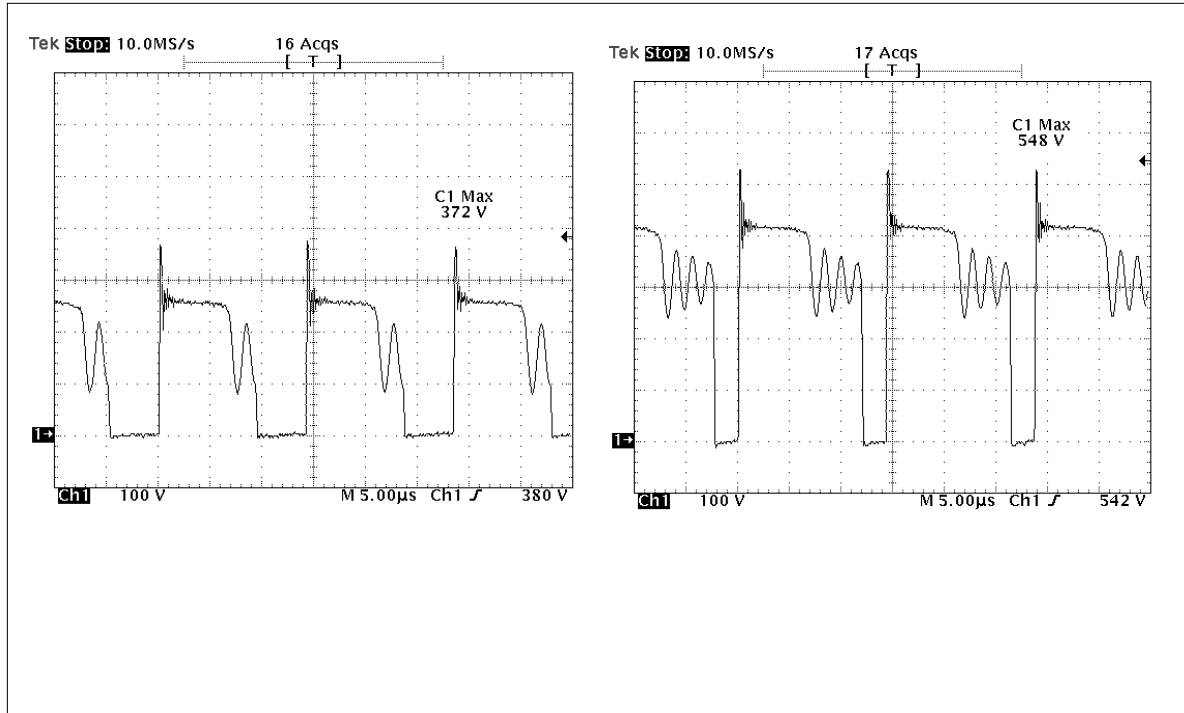

Figure 7:  $V_{DS}$  during start-up at 110V<sub>ac</sub> and 220V<sub>ac</sub>

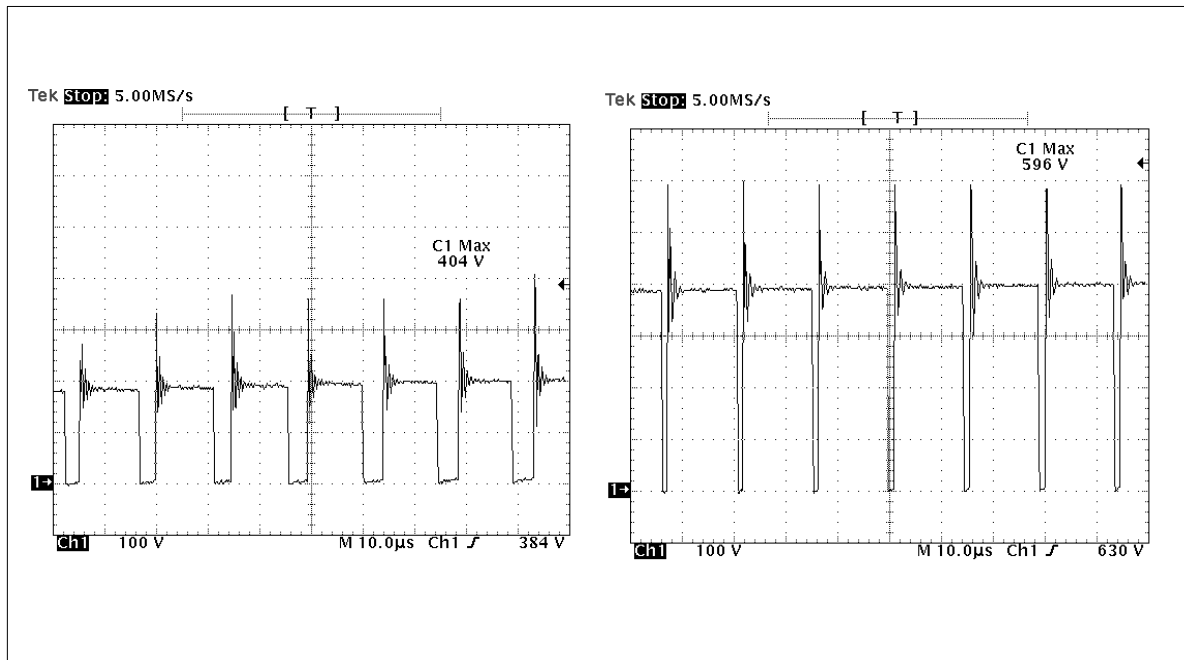

Figure 8: Start-up time at 110V<sub>ac</sub> and 220V<sub>ac</sub>

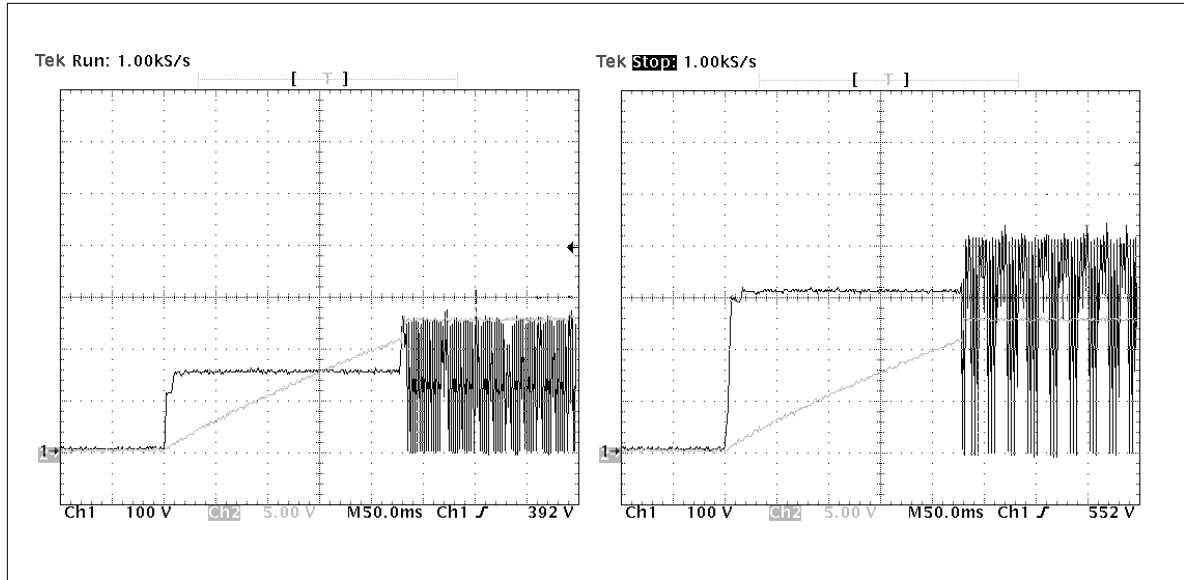
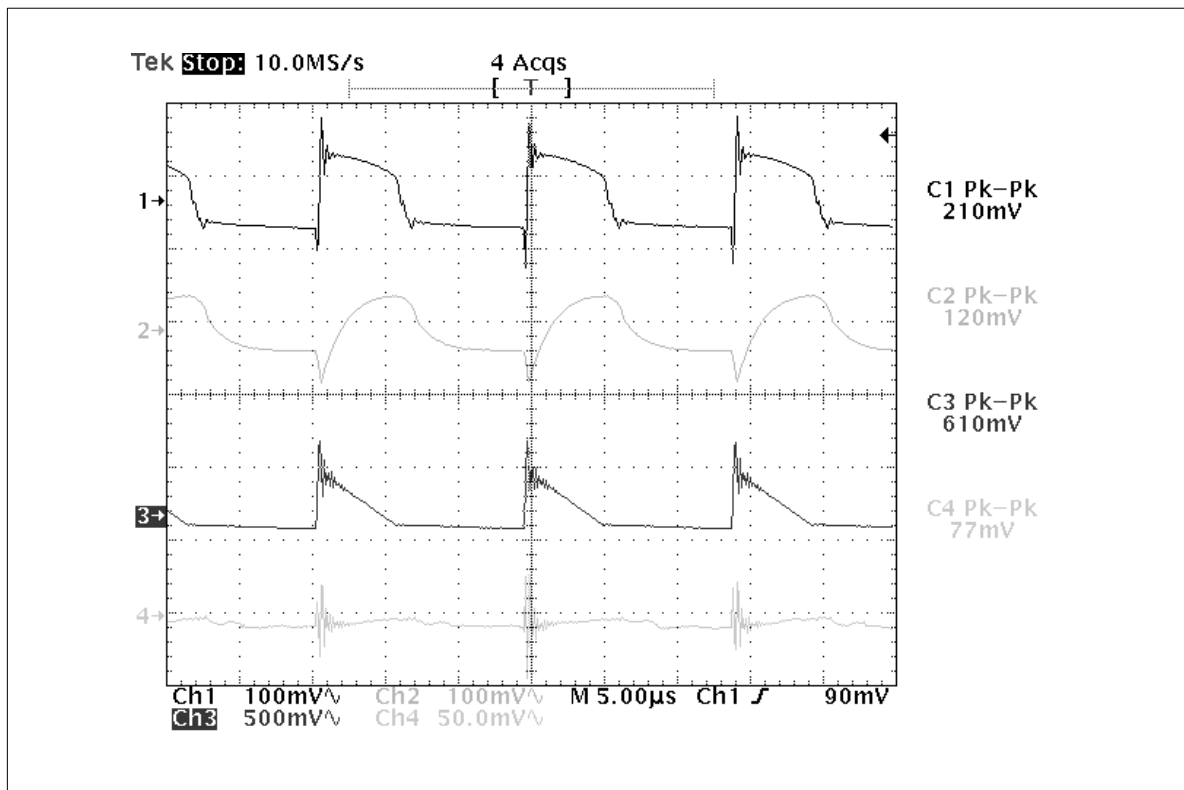

Figure 9: Output voltage ripple at V<sub>in</sub>=220V<sub>ac</sub>: 1) 2.5V, 2) 5V, 3) 12V, 4) 22V



### 3.2 SHORT CIRCUIT BEHAVIOUR

Short circuit protection is provided on any output by means of winding coupling for higher voltage outputs and by means of an auxiliary circuit for 2.5V and 5V outputs (Q1 and Q3 and Figure 3). In the first case the power supply works in hiccup mode while in the second case the output power is limited driving the COMP pin through the optocoupler. In Figure 10 drain and  $V_{DD}$  voltages are shown as the 22V output is short-circuited at  $V_{in}=110V_{ac}$  and  $V_{in}=220V_{ac}$ . In both cases the power dissipation is limited since the power supply works only for some ms. In Figure 11 start-up voltages are shown under short circuit condition on 22V output at  $V_{in}=110V_{ac}$  and  $V_{in}=220V_{ac}$ .

**Figure 10:** Short circuit at  $P_{out,max}$  on 22V output ( $V_{in}=110V_{ac}$  and  $V_{in}=220V_{ac}$ )

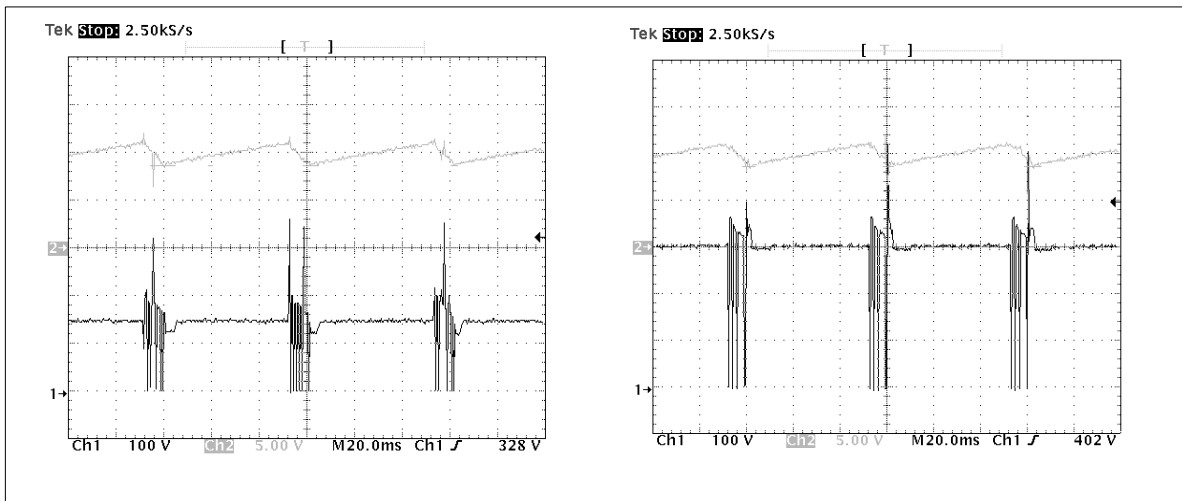

**Figure 11:** Short circuit at  $P_{out,max}$  on 22V output ( $V_{in}=110V_{ac}$  and  $V_{in}=220V_{ac}$ )

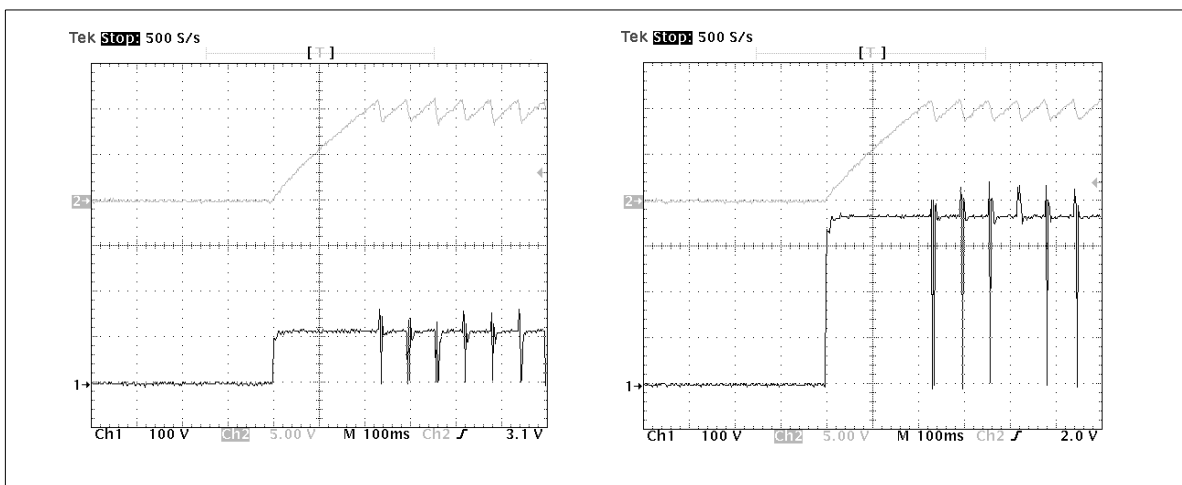

### 3.3 EMI MEASUREMENTS

Conducted EMI measurements have been performed according to EN55022 Class B standard, using a 50W LISN and a spectrum analyzer. In Figure 12 and Figure 13 measurement results are shown under full load condition at nominal  $115V_{ac}$  and  $230V_{ac}$  input voltage, respectively. Although peak detector has been used, the measured emission levels are below the AV (average) limit, passing the pre-compliance test.

**Figure 12:** Conducted emissions at  $110V_{ac}$  (limits EN55022B)

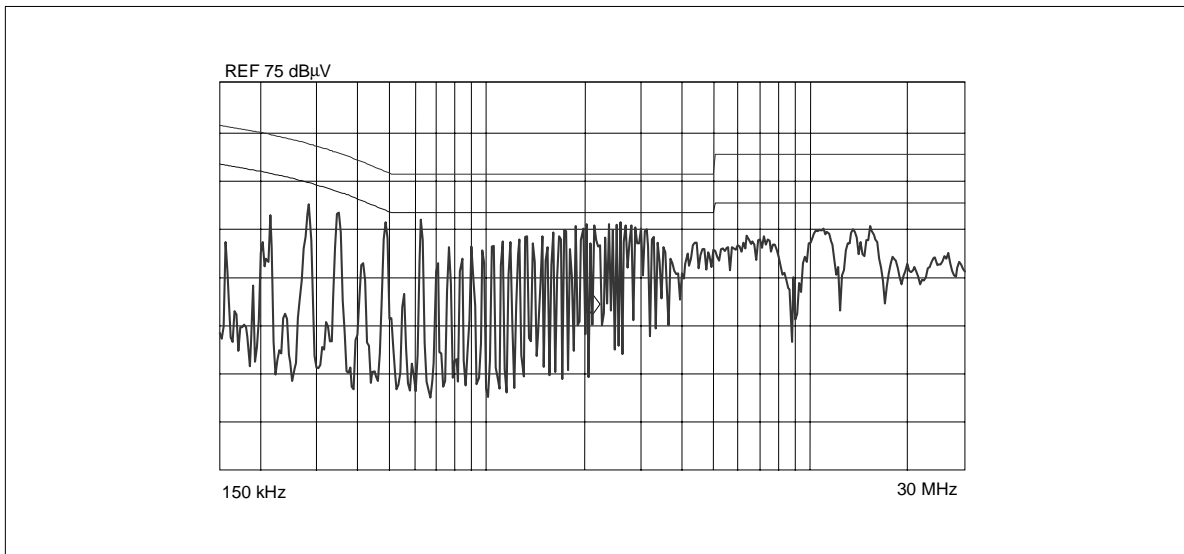

**Figure 13:** Conducted emissions at  $220V_{ac}$  (limits EN55022B)

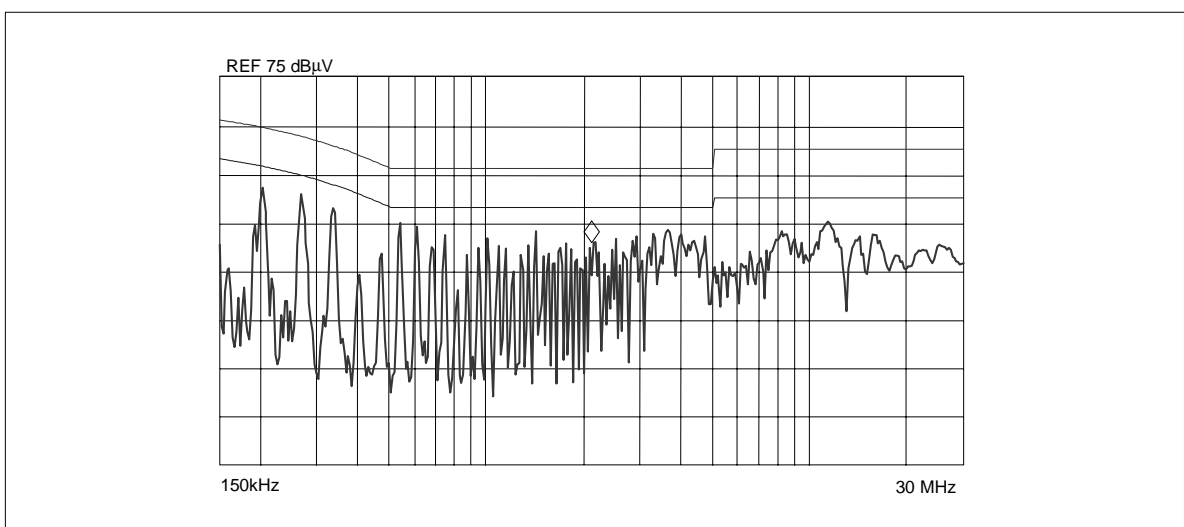

### 3.4 THERMAL MEASUREMENTS

Temperature measurements have been performed in order to provide reliable operation conditions for all the circuit components. In Table 6 the measured values with  $T_{amb}=23^{\circ}\text{C}$ . Only one heatsink has been used in the board, mounted on the VIPer50.

**Table 6:** Temperature characterization

Device	T at 110V <sub>ac</sub>	T at 220V <sub>ac</sub>
VIPer50	66	64
Transil	97	103
D6 (22V)	66	67
D8 (5V)	75	78
D9 (2.5V)	55	58
Transformer	44	43
Bridge	54	46

### 4. CONCLUSIONS

In this paper a low cost SMPS for Set-Top-Box has been introduced and analyzed. Thanks to VIPer features the design and development of the power supply are really straightforward, yielding to a cost effective solution. The built-in functions and protections of the VIPer reduce the external component count, simplifying the circuit. Moreover, EMI behavior and thermal performance allow to use standard components and materials for the PCB, keeping low the cost of the whole system.

The voltage regulation performance confirms the VIPer as the device of choice for low cost high performance power supplies as required by the consumer market.

For further information please contact STMicroelectronics VIPower web site: [www.st.com/vipower](http://www.st.com/vipower).

Information furnished is believed to be accurate and reliable. However, STMicroelectronics assumes no responsibility for the consequences of use of such information nor for any infringement of patents or other rights of third parties which may result from its use. No license is granted by implication or otherwise under any patent or patent rights of STMicroelectronics. Specifications mentioned in this publication are subject to change without notice. This publication supersedes and replaces all information previously supplied. STMicroelectronics products are not authorized for use as critical components in life support devices or systems without express written approval of STMicroelectronics.

The ST logo is a trademark of STMicroelectronics

© 2002 STMicroelectronics - Printed in ITALY- All Rights Reserved.

STMicroelectronics GROUP OF COMPANIES

Australia - Brazil - Canada - China - Finland - France - Germany - Hong Kong - India - Israel - Italy - Japan - Malaysia - Malta - Morocco - Singapore - Spain - Sweden - Switzerland - United Kingdom - U.S.A.

<http://www.st.com>



LittleDiode supplies new, hard to find or obsolete electronic components and semiconductors all over the world.

With over two million different components listed you are sure to find the part you need.

Feel free to visit us today at our online store:

[LittleDiode.com](http://LittleDiode.com)

Looking forward to providing you with the best possible service.