Compatibility Between CS4299 and AD1881

INTRODUCTION

This application note will discuss the problems and possible solutions that are associated with populating a CS4299 into a socket designed for the AD1881. Although the AC '97 spec recommends a standard pinout for all AC '97 compliant codecs, there are subtle differences in the value and hookup of external components that can cause non-interoperability between AC '97 codecs from different manufacturers. The following concerns are of particular interest for customers considering using a CS4299 instead of an AD1881.

1. Reference Capacitors

AD1881 requires 10 μF + 0.1 μF caps on pin 27 (called Vref) while the CS4299 requires 1 μF + 0.1 μF caps on pin 27 (called REFFLT). If a CS4299 is populated into an AD1881 socket, the Crystal part's reference would charge ten times slower than intended and the part might fail calibration or finish calibration with considerable offsets remaining in the analog path and converters.

Depending on layout it may be possible to exchange the 10 μF cap for a 1 μF cap with similar footprint. In particular, if the original design uses a 10 μF surface mount tantalum cap (Panasonic[®] TE series, size code Y) it is easily replaced with a 1206 surface mount ceramic cap (PHILIPS[®] 12062F105M8BB0 or KEMET C1206C105M8VAC).

2. Vrefout Buffering

The AD1881 is designed to source up to 5 mA from Vrefout. Some systems use this feature to supply the microphone bias directly from Vrefout. The CS4299 on the other hand can only source about 100 nA from Vrefout. This is sufficient to bias external op-amps, but running the mic bias off of

Vrefout on a CS4299 will drain the internal reference and prevent the reference from charging to its nominal level. Consequently, the REF bit in register 26h will not be set which in turn will signal an error condition to the controller. Any external loading on Vrefout must be buffered on the CS4299. There's no easy workaround for designs that load Vrefout.

3. AFLT Capacitors

The AFLT caps are spec'ed at 270 pF/NPO for the AD1881 and at 1000 pF/NPO for the CS4299. Running the CS4299 with the 270 pF/NPO caps on AFLT will result in somewhat higher distortion and lower dynamic range on the ADC's, but probably still be acceptable.

These caps are easily interchangeable since the larger cap is available in the same footprint as the smaller one and a replacement is recommended. If a surface mount ceramic cap (any manufacturer, size code 0805) was used originally, replace with KEMET[®] C0805C102J5GAC.

4. 3D Capacitors

To complete the 3D circuitry, the AD1881 requires a 100 nF cap between pins 33 (called CX3D) and 34 (called RX3D). In addition, the AD1881 requires a 47 nF cap between pin 34 and AGND. Furthermore, the AD1881 requires 1 μF /ELEC caps from pins 32 (called FILT_L) and 31 (called FILT_R) to AGND. The CS4299 on the other hand requires a 1000 pF cap between pins 33 (called FLTI) and 34 (called FLTO), as well as a 0.01 μF cap from pin 32 (called FLT3D) to AGND. Because of the vastly different cap values and connectivity, dropping a CS4299 into an AD1881 socket will almost certainly render the 3D feature on the

CS4299 useless. It should however be possible to change an existing socket to accept a CS4299 by:

- replacing the 100 nF cap between pins 33 and 34 with a 1000 pF cap, if a surface mount ceramic cap (any manufacturer, size code 0805) was used originally, replace with KEMET C0805C102J5GAC
- removing the 47 nF cap between pin 34 and AGND,
- replacing the 1 μ F cap between pin 32 and AGND with a 0.01 μ F cap, if a surface mount tantalum cap (Panasonic TE series, size code Y) was used originally, replace with KEMET C1206C103K5RAC
- removing the 1 μ F cap between pin 31 and AGND.

5. Output Filtering Capacitors

Finally, the AD1881 doesn't require external filter caps on the analog outputs. The CS4299 spec's 680 pF to 1000 pF caps from all used analog outputs to AGND. Since the corresponding pads do not exist on an AD1881 socket it will be hard to add these caps after the fact. The CS4299 will still function properly without these caps, but out of band energy from the DAC modulators will increase on the analog outputs. This could cause distortion on the amplifiers of the following stage if they cannot slew fast enough to keep up with the high frequency components in the analog output. This may or may not be acceptable and requires tests on the part of the vendor.

ADDENDUM

A schematic as well as gerber drawings have been included that show how to accommodate both devices in a single layout. They may be used as a guideline for designs that wish to be compatible with both, the CS4299 and the AD1881.

Contacting Cirrus Logic Support

For a complete listing of Direct Sales, Distributor, and Sales Representative contacts, visit the Cirrus Logic web site at: <http://www.cirrus.com/corporate/contacts/>

PANASONIC is a registered trademark of Matsushita Electric Industrial Company, Ltd.

PHILIPS is a registered trademark of Philips Electronics

KEMET is a registered trademark KEMET Electronics Corporation

Preliminary product information describes products which are in production, but for which full characterization data is not yet available. Advance product information describes products which are in development and subject to development changes. Cirrus Logic, Inc. has made best efforts to ensure that the information contained in this document is accurate and reliable. However, the information is subject to change without notice and is provided "AS IS" without warranty of any kind (express or implied). No responsibility is assumed by Cirrus Logic, Inc. for the use of this information, nor for infringements of patents or other rights of third parties. This document is the property of Cirrus Logic, Inc. and implies no license under patents, copyrights, trademarks, or trade secrets. No part of this publication may be copied, reproduced, stored in a retrieval system, or transmitted, in any form or by any means (electronic, mechanical, photographic, or otherwise) without the prior written consent of Cirrus Logic, Inc. Items from any Cirrus Logic website or disk may be printed for use by the user. However, no part of the printout or electronic files may be copied, reproduced, stored in a retrieval system, or transmitted, in any form or by any means (electronic, mechanical, photographic, or otherwise) without the prior written consent of Cirrus Logic, Inc. Furthermore, no part of this publication may be used as a basis for manufacture or sale of any items without the prior written consent of Cirrus Logic, Inc. The names of products of Cirrus Logic, Inc. or other vendors and suppliers appearing in this document may be trademarks or service marks of their respective owners which may be registered in some jurisdictions. A list of Cirrus Logic, Inc. trademarks and service marks can be found at <http://www.cirrus.com>.

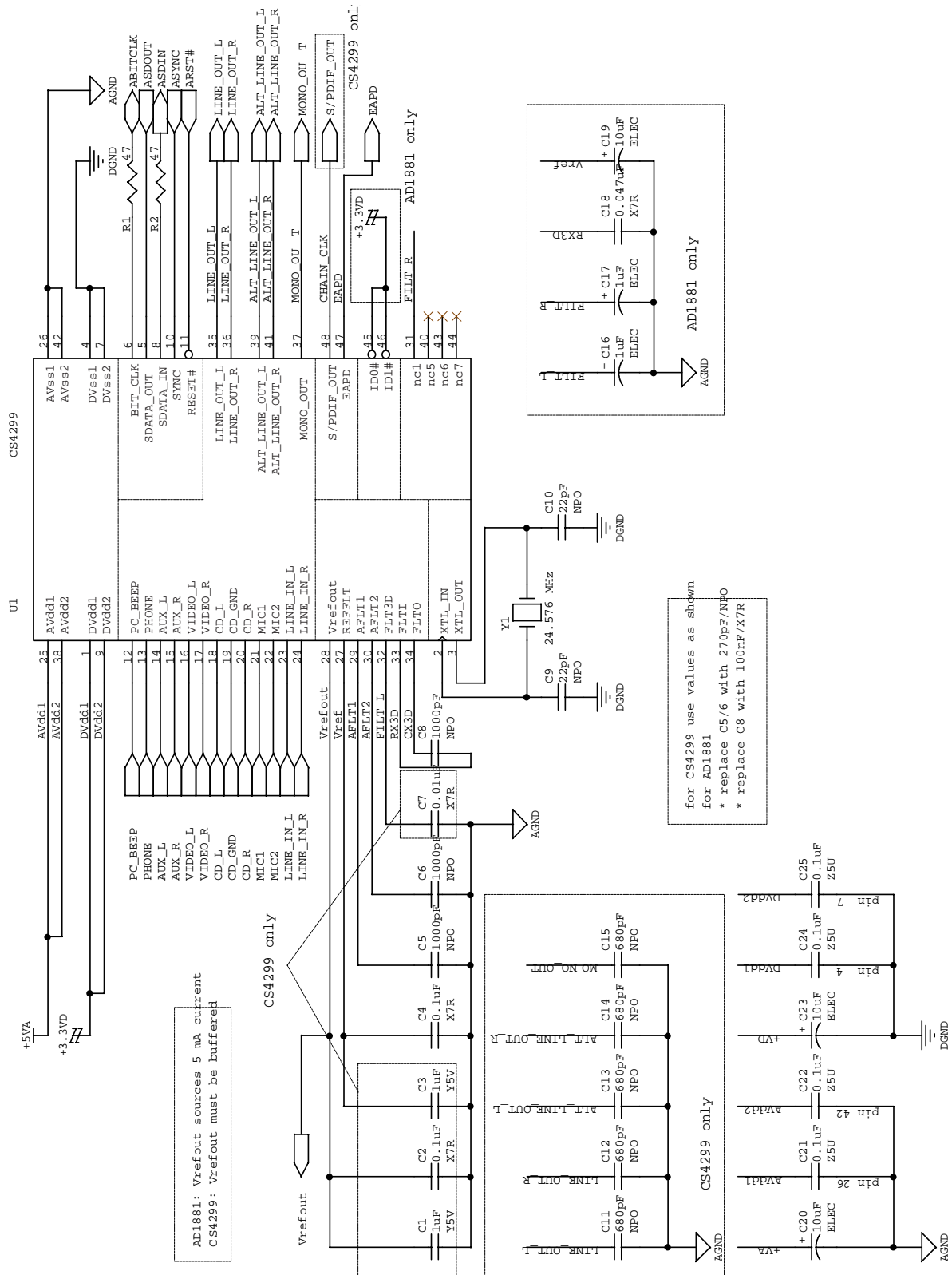

Figure 1. Schematics

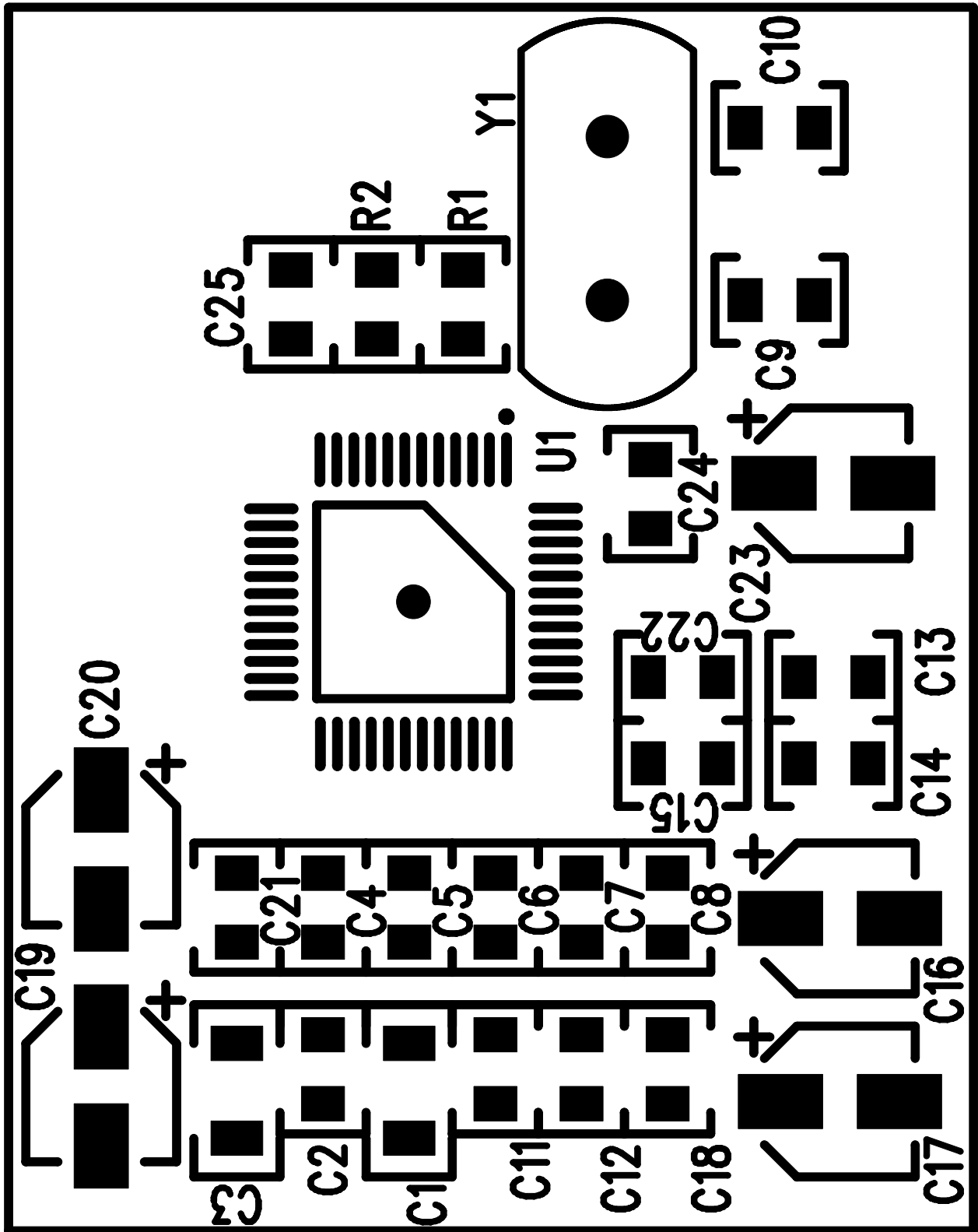

Figure 2. Assembly

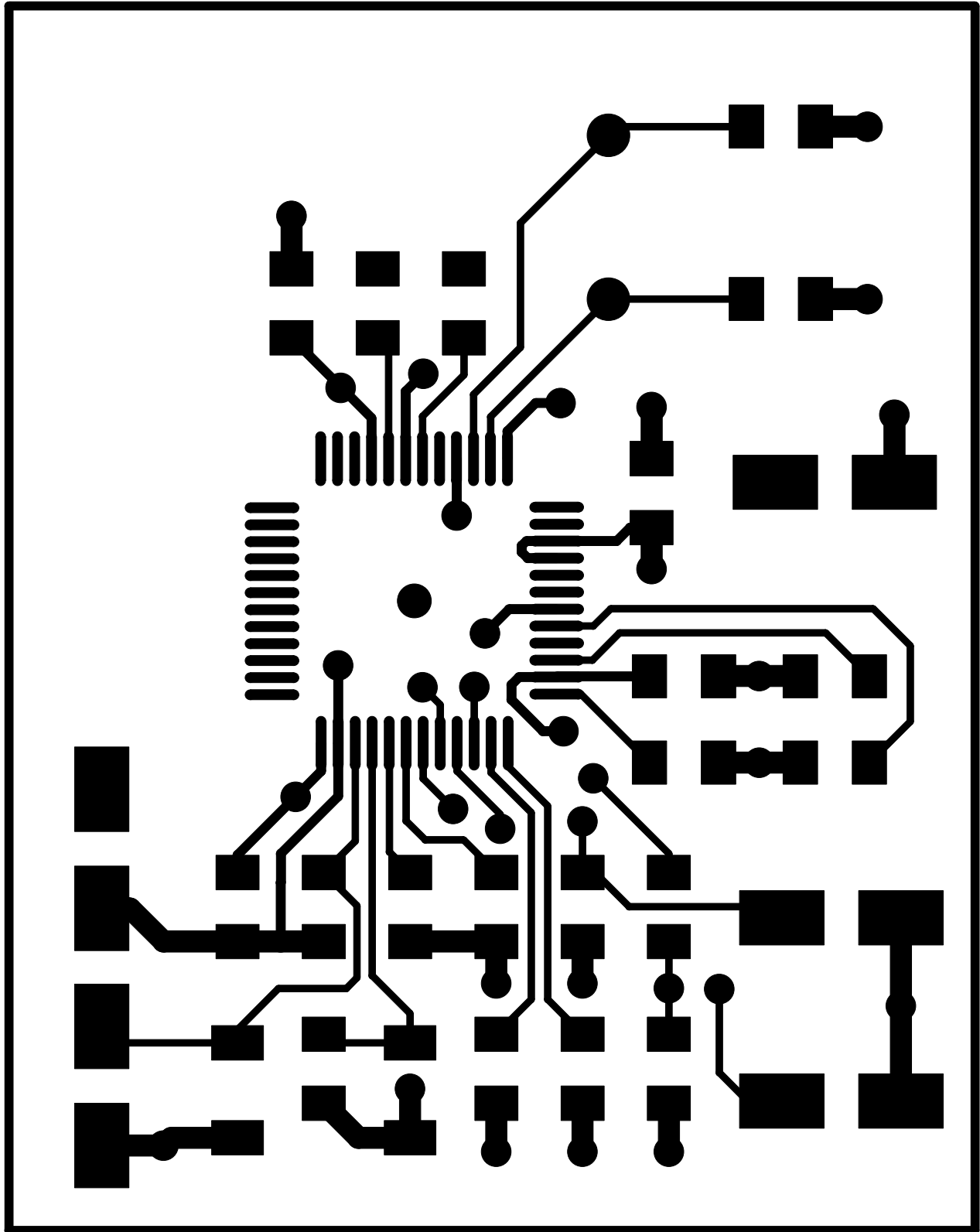

Figure 3. Top Layer

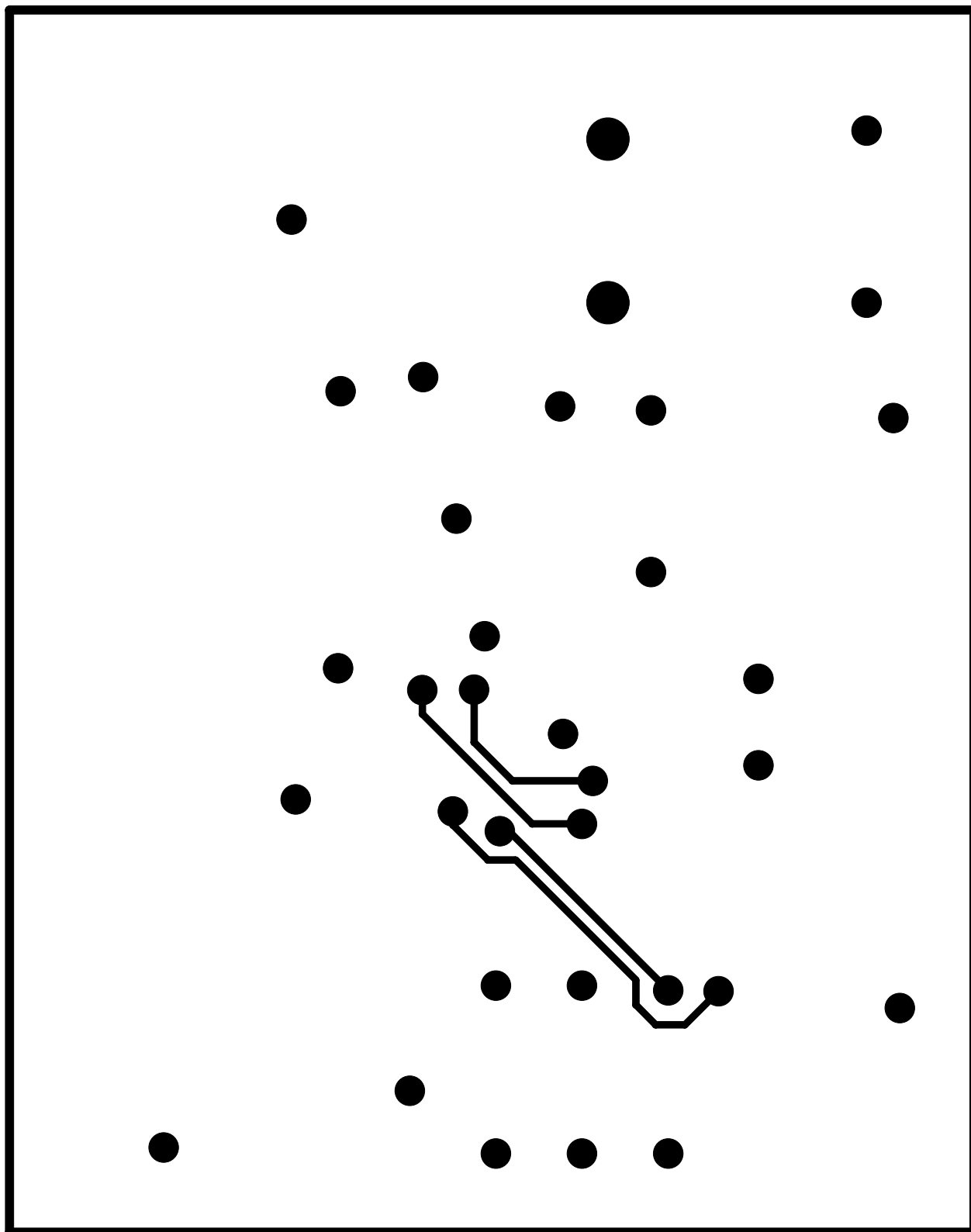

Figure 4. Bottom Layer

• **Notes** •

SMART
Analog™



LittleDiode supplies new, hard to find or obsolete electronic components and semiconductors all over the world.

With over two million different components listed you are sure to find the part you need.

Feel free to visit us today at our online store:

LittleDiode.com

Looking forward to providing you with the best possible service.