



AN1524 APPLICATION NOTE

74ACT1284 STANDARD LOGIC: A HIGH SPEED IEEE 1284 TRANCEIVER

M. Porto

1. INTRODUCTION.

The communication standard IEEE 1284 was created to supply the need for an existing defined standard for bi-directional parallel communication between the PC and printing peripherals. Being backward compatible with the old specification Parallel Centronics, this standard offers more functionality and performance for new PC and peripheral products. 74ACT1284 is designed to be compliant with both the IEEE1284 and Parallel Centronics Standards.

2. DEVICE DESCRIPTION.

74ACT1284 can be used in EPP, ECP and Byte modes.

- The ECP (Extended Capabilities Port) mode provides an asynchronous, bi-directional, parallel peripheral interface for personal computers.
- The EPP (Enhanced Parallel Port) mode allows high-speed transfers in either direction. This mode is ideal for real-time-controlled peripherals, such as network adapters, data acquisition and other devices.
- The Byte mode allows the transfer of data in the reverse direction if the data lines are bi-directional.

These devices allow data transmission in the A-to-B direction or B- to-A direction, depending on the logic level of the direction-control pin (DIR).

Figure 1: Pin Layout

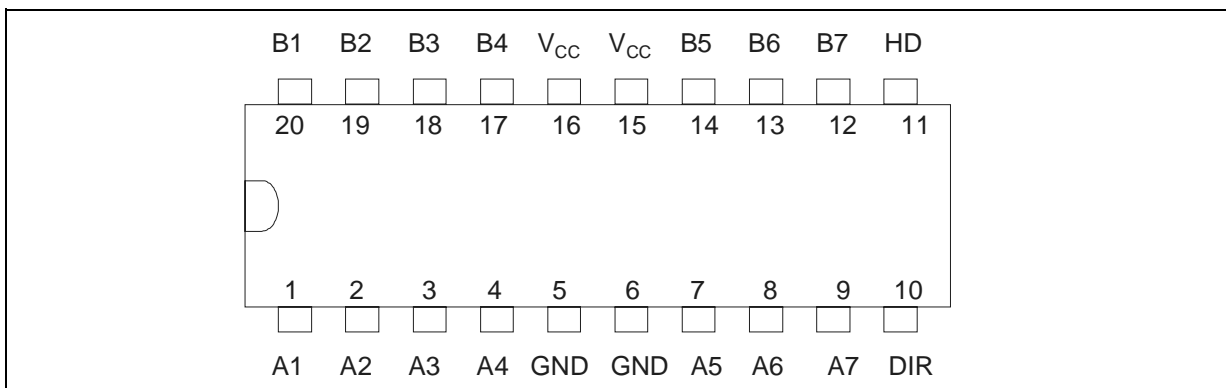

The output drive mode is determined by the high-drive control pin (HD). HD enables the outputs B to switch from open collector to totem pole. The A side outputs have totem-pole outputs only.

Table 1 shows the pin outs and function of this device:

Table 1: Pin Outs And Functions

PIN NUMBER	SYMBOL	NAME & FUNCTION
11	HD	High Drive Enable Inputs
10	DIR	Direction Control Inputs
1 - 4	A1 - A4	Side A Inputs or Outputs
17 - 20	B4 - B1	Side B Inputs and Outputs
7 - 9	A5 - A7	Side A Input
12 - 14	B7 - B5	Side B Output
15 - 16	V _{CC}	Power Supply
5 - 6	GND	Ground

The features and benefits of IEEE 1284 STD are summarized in the table below.

Table 2: Features And Benefits Of IEEE 1284 Standard

FEATURES	BENEFITS
5V ± 10% V _{CC}	
TTL-compatible inputs	
Flow-through architecture	Optimizes printed circuit board layout
Center pin V _{CC} and GND configuration	Minimizes high speed switching noise
A to B and B to A transmission for bits 1, 2, 3 and 4	Configurable data flow
14mA B port output currents	
Guarenteed 350mV minimum hysteresis	
Fastest device on the market	Maximum tpd 6.5ns @ V _{CC} = 4.5V
SO and TSSOP packaging	

The device is designed with 300mV of hysteresis in order to filter input noise and to prevent false commutation when a slow input edge is applied to the input.

Figure 2: Static Thresholds Typical Value

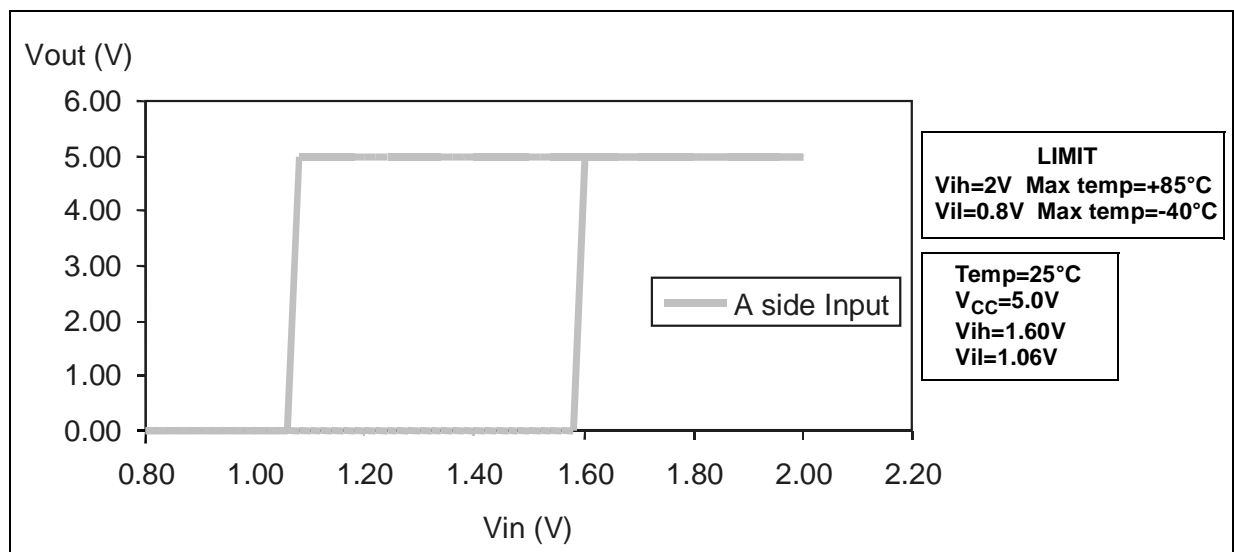

3. OUTPUT IMPEDANCE MEASUREMENT TECHNIQUE.

For these measurements we have to prepare the testing bench as seen in the following figure.

Figure 3: Output Impedance Testing Bench

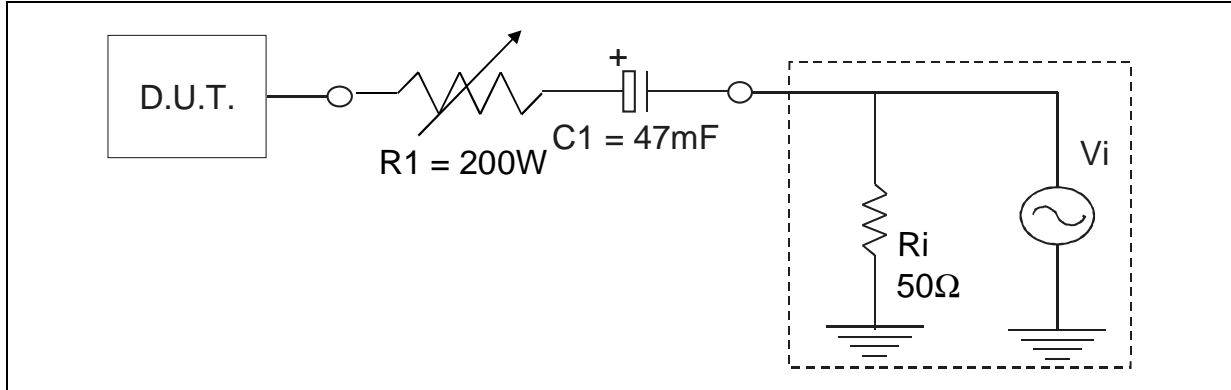

By means of waveform generator a sine wave signal is applied, with amplitude of 1Vpp and frequency of 100Khz in order to avoid parasitic Jig capacitances that could affect the measurement accuracy.

Then the generator is connected to circuit made by a 47μF capacitor, that uncouples the DC voltage between the generator and the D.U.T., and a 200Ω trimmer is used as a voltage divider in combination with the D.U.T. output impedance.

Figure 4: Output Impedance Block Diagram

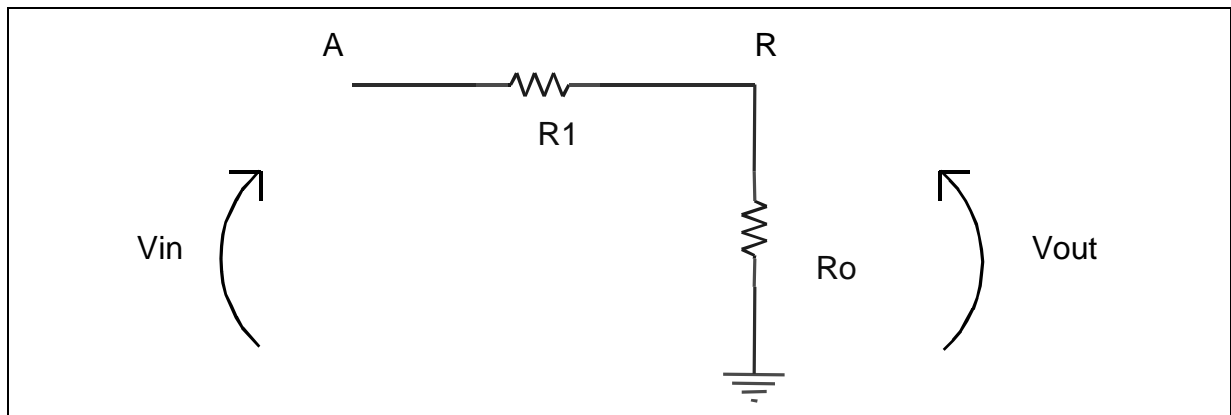

$$V_{out} = \frac{V_{in} \times R_o}{R_o + R_1} \quad (1)$$

$$R_o = \frac{V_{out} \times R}{V_{in} - V_{out}} = \frac{\frac{V_{out}}{V_{in}} \times R}{\frac{V_{in}}{V_{in}} - \frac{V_{out}}{V_{in}}} = \frac{X \times R}{1 - X} \quad (2)$$

When

$$X = \frac{V_{out}}{V_{in}}$$

AN1524 - APPLICATION NOTE

When we inject a signal on point A and we measure the transfer characteristic over R1, (R as output), the following comparison is in force:

$$\frac{A}{R} = 20\log \frac{V_{out}}{V_{in}} = 20\log X \quad (3)$$

We can measure A / R => Out of formula (3) we can calculate X => by filling in X in formula (2), we find Ro.

If we look at these calculations we see that we only need a certain resistance value for R1. If we know this resistance, we only need to measure A / R and then make the calculation.

We do these measurements in function with the following parameters:

- Supply voltage: 4.5V - 5.5V
- Temperature: 25°C - 45°C
- Batch: Almost impossible

Using this measurement technique, the ST1284 output impedance measures at 27Ω (typ).

4. APPLICATION INFORMATION.

Before IEEE 1284 STD, there was no defined electrical specification for the driver, receiver, termination, and capacitance requirements that require compatibility between devices. Host adapters and peripherals were built with different pull-up values on the control lines, open-collectors or open-drain, and totem-pole drivers for the data and control lines. Frequently 10nF capacitors were used on the data and strobe lines.

A typical application circuit before IEEE1284 STD is show below.

Figure 5: A Typical Application Circuit Before IEEE 1284 STD

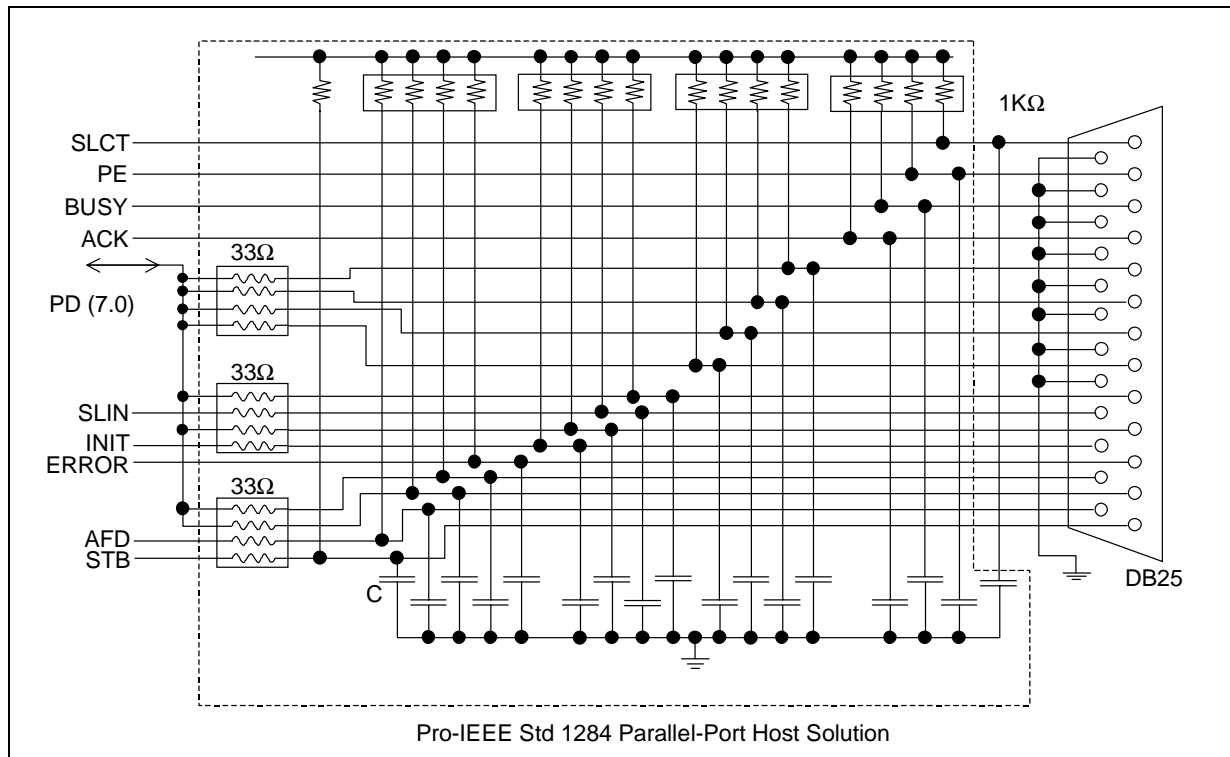

The next figure shows the same application using the IEEE 1284 STD device

Figure 6: A Typical Application Circuit Using The IEEE 1284 STD

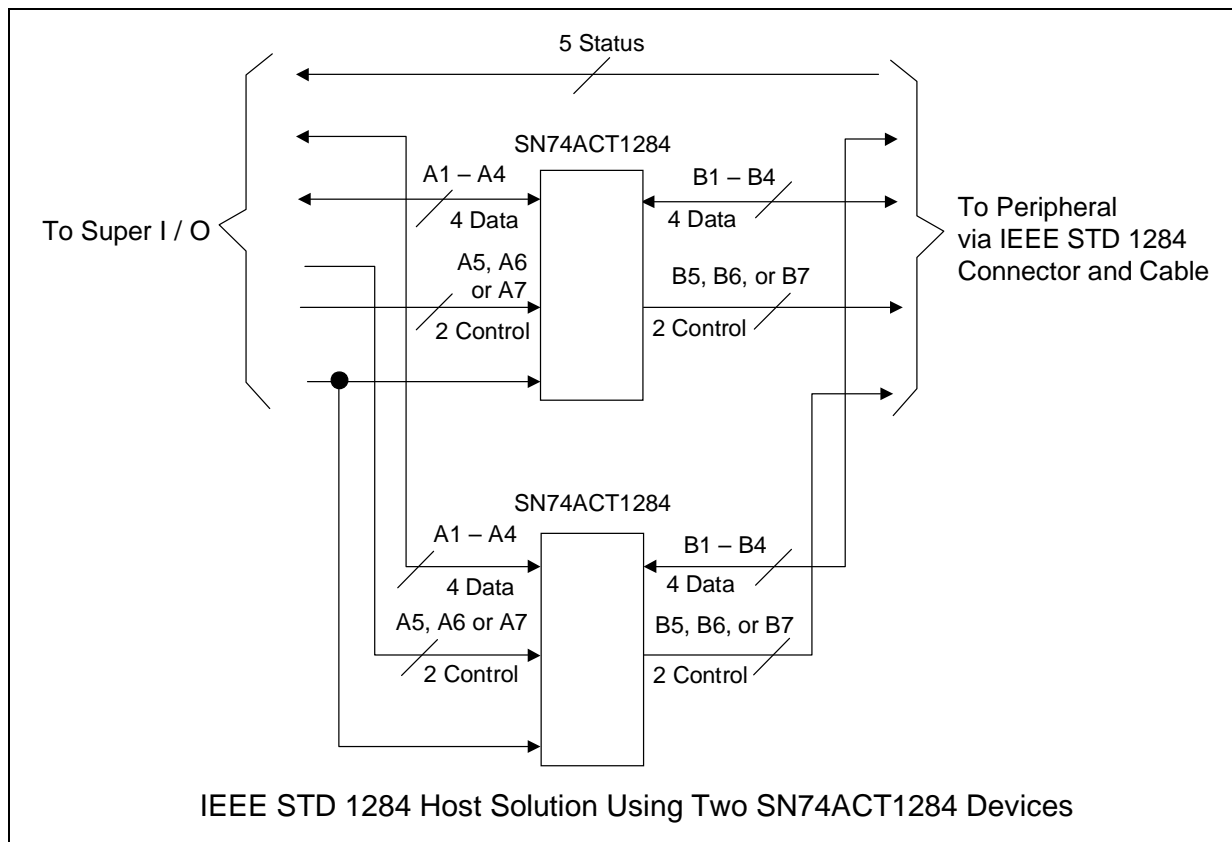

5. CONCLUSION.

This report gives a brief description on STMicroelectronics' STD IEEE1284 device, which offers superior performance when compared with competition. Furthermore, this report was designed to help choose the correct bus interface device in STD IEEE1284 applications.

Information furnished is believed to be accurate and reliable. However, STMicroelectronics assumes no responsibility for the consequences of use of such information nor for any infringement of patents or other rights of third parties which may result from its use. No license is granted by implication or otherwise under any patent or patent rights of STMicroelectronics. Specification mentioned in this publication are subject to change without notice. This publication supersedes and replaces all information previously supplied. STMicroelectronics products are not authorized for use as critical components in life support devices or systems without express written approval of STMicroelectronics.

The ST logo is a registered trademark of STMicroelectronics

© 2002 STMicroelectronics - Printed in Italy - All rights reserved

STMicroelectronics GROUP OF COMPANIES

Australia - Brazil - Canada - China - Finland - France - Germany - Hong Kong - India - Israel - Italy - Japan - Malaysia - Malta - Morocco - Singapore - Spain - Sweden - Switzerland - United Kingdom - U.S.A.

<http://www.st.com>



LittleDiode supplies new, hard to find or obsolete electronic components and semiconductors all over the world.

With over two million different components listed you are sure to find the part you need.

Feel free to visit us today at our online store:

LittleDiode.com

Looking forward to providing you with the best possible service.