

Application Note

USING THE CS5521/23, CS5522/24/28, AND CS5525/26 CHARGE PUMP DRIVE FOR EXTERNAL LOADS

By Bill Durbin and Jerome Johnston

INTRODUCTION

The CS5521/23, CS5522/24/28, and CS5525/26¹ series of A/D converters include on-chip circuitry to drive and regulate a diode charge pump. The purpose of this application note is to explain the charge pump circuitry and how it can be used in a system design.

CS552X Overview

The CS5521/23, CS5522/24/28, and CS5525/26 series of A/D converters include a chopper-stabilized instrumentation amplifier for measurement of low level dc signals (± 100 mV or less). This amplifier is designed to produce very low input sampling

current ($I_{CVF} < 300$ pA over -40 to $+85$ C). A low input current minimizes the errors that can occur in thermocouple measurements when high impedance circuitry is used for input protection as shown in Figure 1.

The charge pump circuitry, illustrated in Figure 1, is used to generate a negative supply (approximately -2.1 V) to power the on-chip instrumentation amplifier. This enables the amplifier to measure low level input signals that are negative relative to ground while maintaining low input current. Within certain constraints, which are described in this document, the charge pump can be used to power some additional circuitry outside the converter, such as an amplifier or a multiplexer.

1. The CS5529 is not included in this Application Note because it does not contain a charge pump.

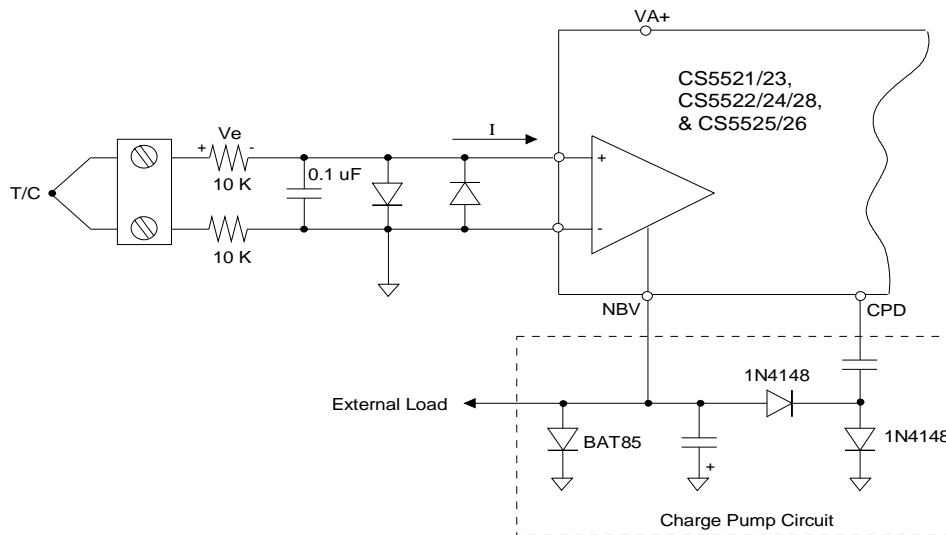

Figure 1. Input Amplifier inside CS552x ADCs.

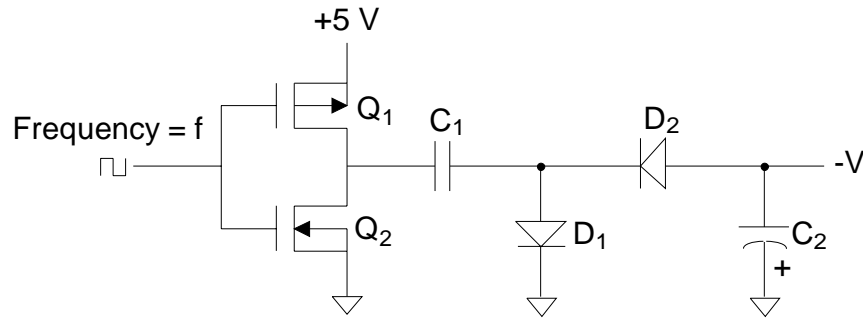

Figure 2. Charge Pump Components

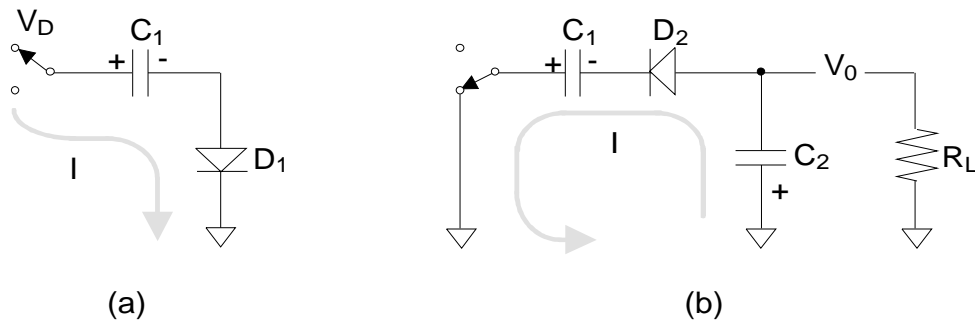

Figure 3. Charge Pump Cycle Sequence

Charge Pump Basics

Figure 2 illustrates a basic diode charge pump. Transistors Q1 and Q2 represent the output transistors of a CMOS inverter. When the input to the inverter causes transistor Q1 to be turned on (Q2 is off) C1 is charged through diode D1 to a voltage of approximately 5 V minus the forward voltage of the diode. When the output of inverter switches to Q1 off, Q2 on, the positively charged lead of C1 will be connected to ground. Since the voltage across a capacitor cannot change instantaneously, the lead of C1 which is connected to diode D2 will go negative, turning on diode D2. The charge on C1 will then flow onto C2 and produce a negative output voltage. Capacitor C2 acts as a reservoir for charge and is much larger than the charge pump capacitor C1. After many charge pump cycles, capacitor C2 will be charged to a voltage that is about two diode drops below 5 V.

Figure 3 illustrates each of the two charge pump se-

quences. Capacitor C2 acts as a reservoir for charge and is much larger than the charge pump capacitor C1.

The CS552X’s Charge Pump

Figure 4 illustrates a simplified version of the basic charge pump regulation loop that is inside the A/D converters listed in this application note. The charge pump drive pin (CPD) is driven from a clock (CPCLK) derived from the XIN frequency. In the CS5525 and CS5526 the XIN frequency is used directly. The CS5521/22/23/24/28 devices use a clock that is XIN/2. A regulator loop compares the magnitude of the voltage generated on the charge reservoir capacitor to a proportion of the VA+ supply magnitude. The loop is designed to regulate the voltage at NBV to be $-[VA+/2.38]$ V. Note that if the VA+ supply voltage to the chip is above +5 V, the voltage that results out of the charge pump on NBV will be proportionally more negative. When the voltage on the NBV pin reach-

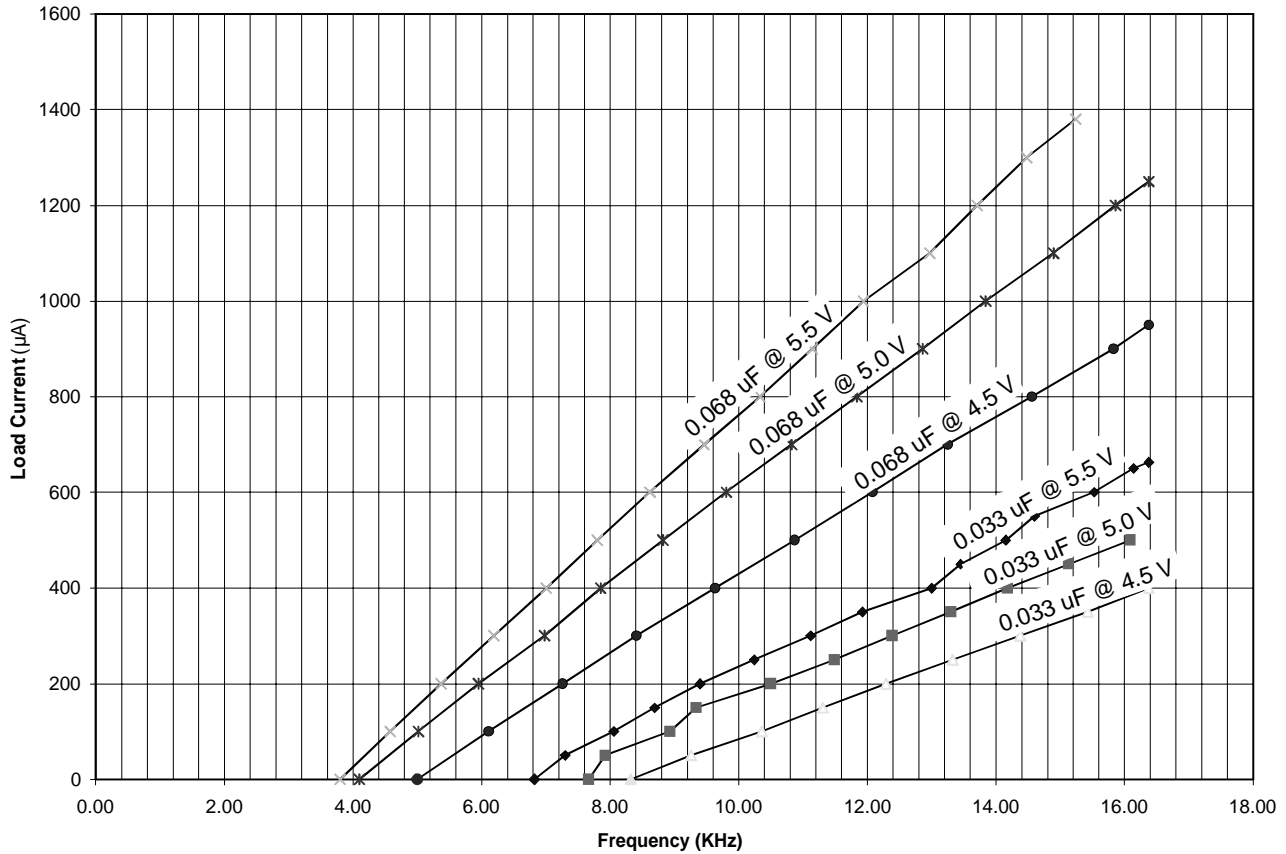

Figure 6. Load Current vs. Frequency for the CS5521/23 and CS5522/24/28; VA+ = VD+

plot shows that if the charge pump output has no external load, its average output frequency (VA+ = 5 V, C = 0.033 µF) is approximately 8 kHz which is about ½ the maximum possible output frequency. The charge pump runs at this average frequency to support the load of the on-chip instrumentation amplifier.

Figure 7 illustrates load current vs. CPD frequency for the CS5525/26 devices. The charge pump clock (CPCLK) is derived from XIN (set to 32.768 kHz), therefore the maximum frequency which can be output from CPD is equal to XIN.

The plots show data similar to that in figure 6. Because the charge pump frequency in the CS5525/26 devices is twice as fast as that used in the CS5521/22/23/24/28 devices, the charge pump capacitor is ½ the size (for the same XIN clock frequency).

Figure 8 illustrates the CS5521/22/23/24/28 with the charge pump capacitor increased to 0.15 µF. This charge pump capacitor is about 4.5 times larger than the nominal capacitor. Under this condition the charge pump could readily supply 2 mA to an external load. While the plot indicates that 3 mA can be supplied, it is not recommended that the external load exceed 2 mA. This allows for some margin in the design. The actual maximum output load capability is affected by the tolerances of VA+, VD+, and the tolerance limits of the charge pump capacitor.

Figures 9 and 10 illustrate the CS5521/22/23/24/28 running with a VD+ supply of 3 V. Figure 9 indicates the variation in load current capability when VA+ varies from 4.5 to 5.5 V (VD+ = 3.0 V). Figure 10 illustrates the variation in load capability when VA+ is a constant 5.0 V, but VD+ is varied

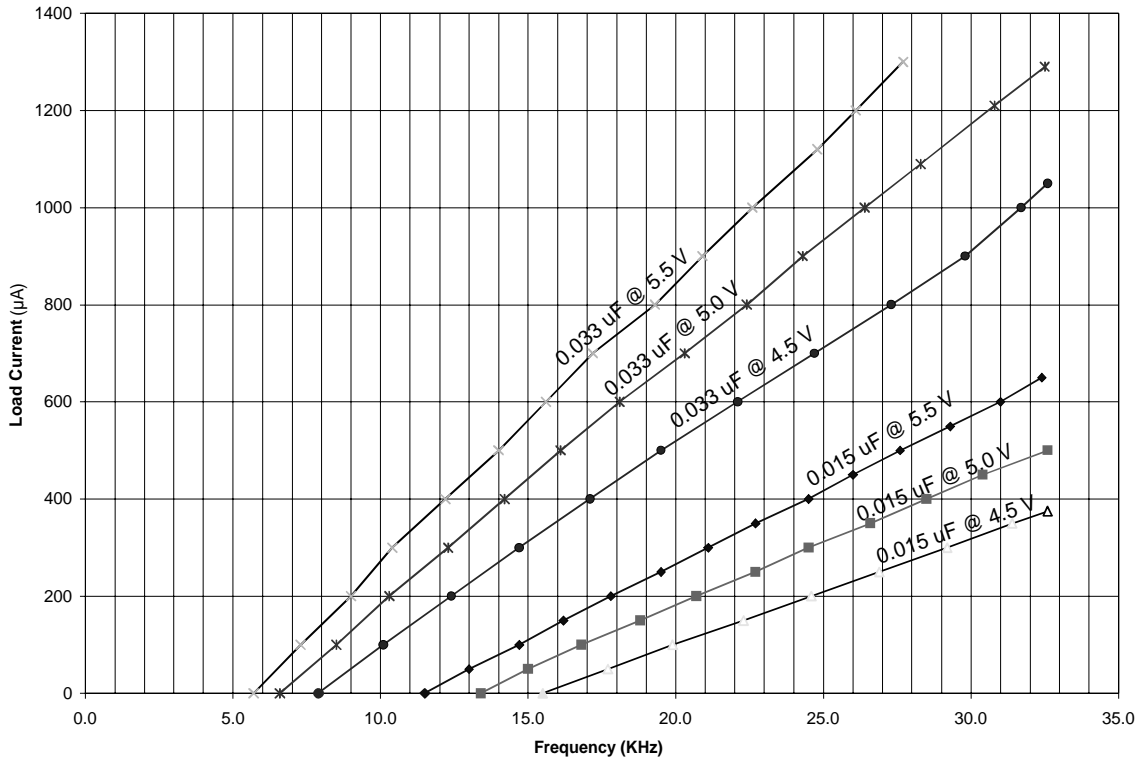

Figure 7. Load Current vs. Frequency for the CS5525/26; VA+ = VD+

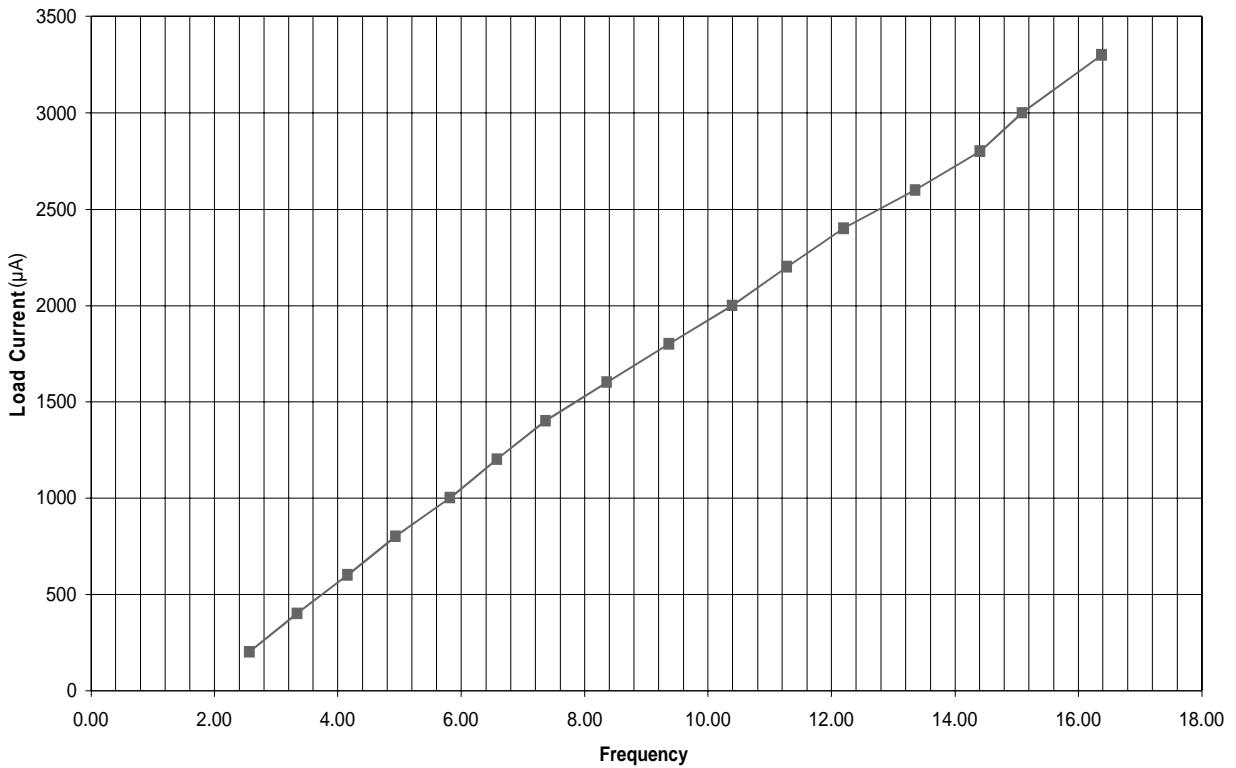
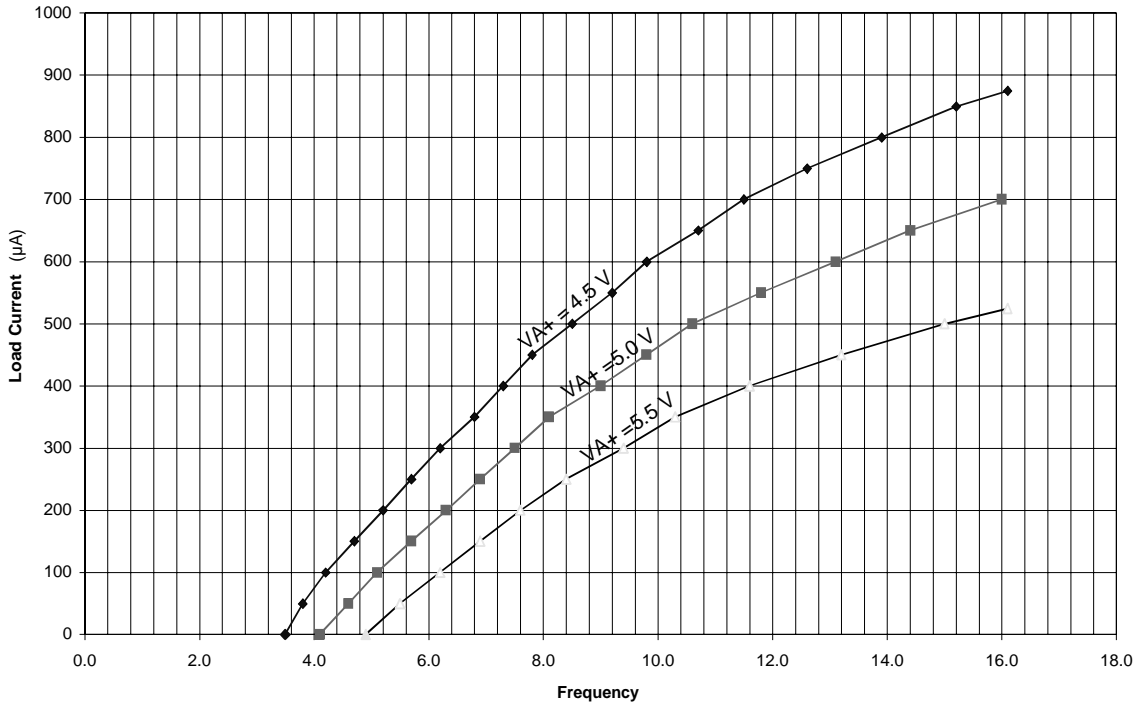
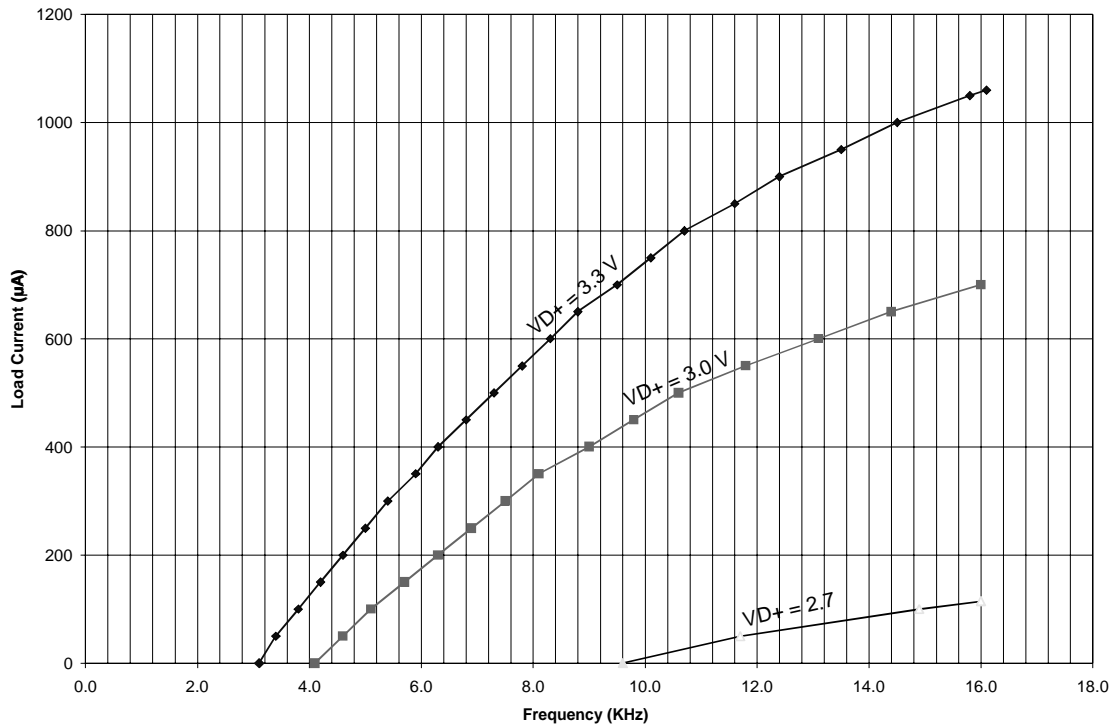

Figure 8. Load Current vs. Frequency; VA+ = VD+ = 5 V, Capacitor Size = 0.15 uF; CS5521/22/23/24/28



**Figure 9. Load Current vs. Frequency for VD+ = 3.0 V, Capacitor Sizes = 0.47 uF
CS5521/22/23/24/28**



**Figure 10. Load Current vs. Frequency for VA+ = 5.0 V, Capacitor Sizes = 0.47 uF
CS5521/22/23/24/28**

from +3.3 down to 2.7 V. The external load capability of the charge pump is limited when VD+ gets to 2.7 V.

Running the CS552X at Frequencies other than 32.768 kHz

The XIN frequency into the converters is used to derive the charge pump clock frequency. The XIN frequency is nominally 32.768 kHz. If this fre-

quency is changed to some other frequency, the charge pump capacitor should be scaled inversely. For example, if XIN is scaled from 32.768 kHz to 100 kHz, the charge pump capacitor should be reduced to about 1/3 of the value used at 32.768 kHz. See the appendix for more exact equations which can help determine the value of the charge pump capacitor.

APPENDIX

Equation for charge pump as depicted in figure 4.

$$I = vfc$$

Current = Voltage x Frequency x Capacitor

$$I_{NBV} + I_{EXT} = [(VD+) - (2 \times V_D) - (2.1 V)] [\eta \text{ CPCLK}] [C_C]$$

I_{NBV} = Current via NBV pin. Nominally 450µA for CS5525/26; 375 µA for CS5521/23; and 700 µA for CS5522/24/28.

I_{EXT} = Current via External Load

VD+ = VD+ supply Voltage; typically 5 V.

V_D = Forward Diode Voltage; typically 0.65 V.

-2.1 V = Regulated value of NBV (could use VA+/2.38 if VA+ is other than 5.0 V).

CPCLK = Charge Pump Clock. Nominally 32.768 kHz for CS5525 and CS5526; 16.384 kHz for CS5521/22/23/24/28.

η = Duty cycle of CPCLK (average CPCLK frequency / maximum CPCLK frequency) to regulate NBV, typically 0.3 to 0.7.

Choose C_C to give the proper $I_{NBV} + I_{EXT}$ with the lowest VD+ and η set to some value between 0.3 and 0.7.

Note: **I_{EXT} should never exceed 2 mA.**

SMART
Analog™



LittleDiode supplies new, hard to find or obsolete electronic components and semiconductors all over the world.

With over two million different components listed you are sure to find the part you need.

Feel free to visit us today at our online store:

LittleDiode.com

Looking forward to providing you with the best possible service.