



White balance adjustment procedure with ST video solutions in DC coupling mode

In a monitor, the 3 electron guns do not provide the same power. Also on the screen, red green and blue phosphors do not have the same sensibility to the electrons. More, there are gain and DC level dispersions between different amplifiers, inside the amplifier and between the 3 channels. For example, if in a monitor, blue guns are more powerful than red and green guns, the white box normally displayed with equal white and black levels finally looks a bit blue.

A white balance tracking consists in:

- Adjusting the R, G, B Infra-Black level register of the pre-amplifier with a black screen, this is the color adjustment in low luminance.
- Adjusting the R, G, B drive registers of the pre-amplifier with a white box on screen, this is the color adjustment in high luminance.

With white balance tracking, the color temperature of the displayed white box is unchanged whatever the brightness and contrast.

This application note describes 3 methods to perform the white balance tracking with the **ST video kit STV9211 (preamplifier) + STV955x (amplifier)** (DC coupling mode):

Method 1 ([Chapter 3](#)): Brightness after drive in preamplifier.

Method 2 ([Chapter 4](#)): Brightness before drive in preamplifier.

Method 3 ([Chapter 5](#)): Brightness control by G1.

The control of G1- DC level is mandatory with the ST video kit STV9211 + STV955x ([Chapter 2](#))

The method choice is related to what adjustment quality and duration the customer requires.

[Chapter 6](#) is a summary of the 3 methods particularities.

Table of Contents

Chapter 1	Definitions	4
Chapter 2	G1 level control	5
2.1	Sub-brightness control by G1, brightness control by preamplifier	5
2.2	Sub-brightness and brightness control by G1 (method #3)	6
2.3	G1 level control	7
Chapter 3	Method 1- Brightness after drive, in preamplifier	8
3.1	Background	8
3.2	Adjustment duration and performance	8
3.2.1	Tracking duration	8
3.2.2	Tracking performance	9
3.3	Black level area calculation	11
3.4	G1 DAC setting	11
3.5	STV9211 preamplifier software settings	12
3.5.1	Brightness is controlled by preamplifier (register 02)	12
3.5.2	Brightness is after drive (Register 13)	12
3.5.3	Infra-black offset setting (Register 14)	12
3.5.4	Infra-black range setting (register 14)	13
3.5.5	Infra-black level settings (registers 10,11,12)	13
3.5.6	Drive setting (registers 3,4,5)	13
3.6	G2 setting	13
3.7	White balance adjustment procedure	13
Chapter 4	Method 2 - Brightness before drive, in preamplifier	16
4.1	Background	16
4.2	Adjustment duration and performance	16
4.2.1	Tracking performance	16
4.2.2	Tracking duration	18
4.3	Black level area calculation	19
4.4	G1 DAC setting	19
4.5	Preamplifier STV9211 software settings	20

4.5.1	Brightness is controlled by preamplifier (register 02)	20
4.5.2	Brightness is before drive (register 13)	20
4.5.3	Infra-black offset setting (register 14)	20
4.5.4	Infra-black range setting (register 14)	21
4.5.5	Infra-black level settings (register 10,11,12)	21
4.5.6	Drive setting (registers 3,4,5)	21
4.6	G2 setting	21
4.7	White Balance Adjustment procedure	22
Chapter 5	Method 3 - Brightness control by G1	25
5.1	Background	25
5.2	Adjustment duration and performance	25
5.2.1	Tracking duration	25
5.2.2	Tracking performance	26
5.3	Black level area calculation	28
5.4	G1 DAC setting	28
5.5	Preamplifier STV9211 software settings	29
5.5.1	Brightness control by G1	29
5.5.2	Brightness (in preamplifier) after drive (register 13)	29
5.5.3	Infra Black Offset setting (Register 14)	30
5.5.4	Infra-black range setting (register 14)	30
5.5.5	Infra-black level settings (registers 10,11,12)	31
5.5.6	Drives setting (registers 3,4,5)	31
5.6	G2 setting	31
5.7	White balance adjustment procedure	31
Chapter 6	Comparison of the three methods	34

1 Definitions

White balance adjustment target

Y_low_lum	low luminance target
Y_low_lum_tol	tolerance of the low luminance target
Y_high_lum	high luminance target
Y_high_lum_tol	tolerance of the high luminance target
Y_ABL	high luminance target with a full white pattern (for ABL adjustment)
Y_ABL_tol	tolerance of the high luminance target
(x_target, y_target)	color temperature target
(x_target_tol, y_target_tol)	tolerance of the color temperature target.

Video level requirements

V_Contrast	video range requirement (generally 40V)
V_Brightness	brightness range requirement

Others

VDD	video amplifier high voltage power
Sub-Brightness luminance	luminance when the screen is full black with maximum brightness Sub-Brightness is controlled by G1 in each method. Sub-Brightness adjusts the low luminance target.

2 G1 level control

Control G1 level to perform a good white balance tracking with the ST video kit STV9211 + STV955x.

The use of G1 varies with the white balance adjustment method:

- In methods 1 and 2, G1 controls only the sub-brightness.
- In method 3, G1 controls sub-brightness and brightness.

2.1 Sub-brightness control by G1, brightness control by preamplifier

This is achieved in methods 1 and 2. In this case, G1 level is adjusted during the white balance tracking to reach the low luminance target. G1 remains unchanged afterwards.

The sub-brightness level is G1 fixed level.

Figure 1: Brightness control by preamplifier, fixed G1

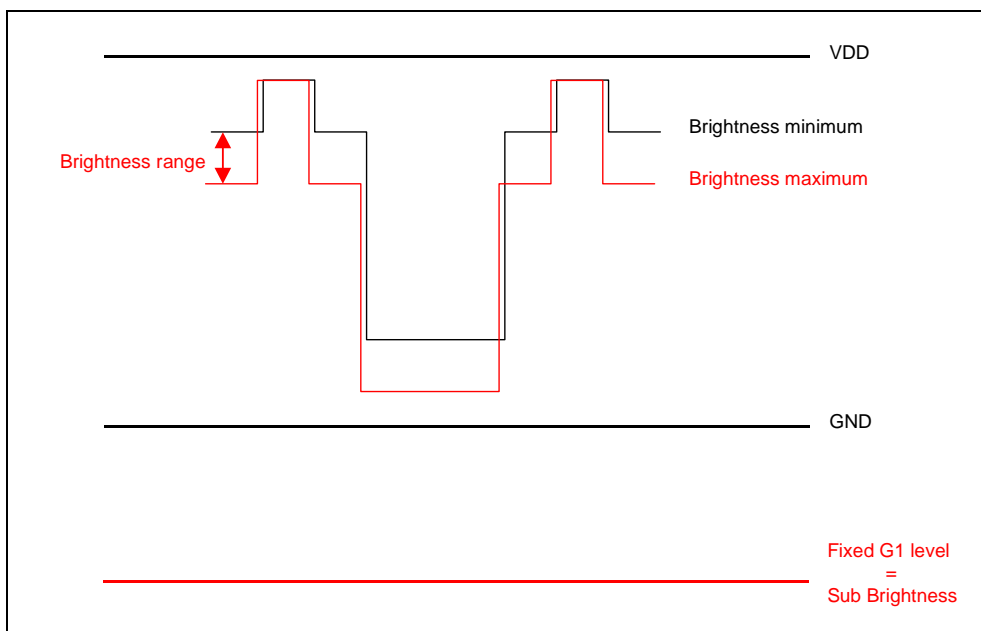

Note: When controlling the brightness by preamp, $V_{G2}-V_{G1}$ remains the same whatever the brightness.

2.2 Sub-brightness and brightness control by G1 (method #3)

In this case, G1 level is adjusted during the white balance tracking to reach the low luminance target. This level is related to the maximum brightness, this is also the sub-brightness level.

When G1 level decreases, the brightness also decreases.

The sub-brightness level corresponds to G1 level with maximum brightness.

Figure 2: Brightness control by G1, variable G1

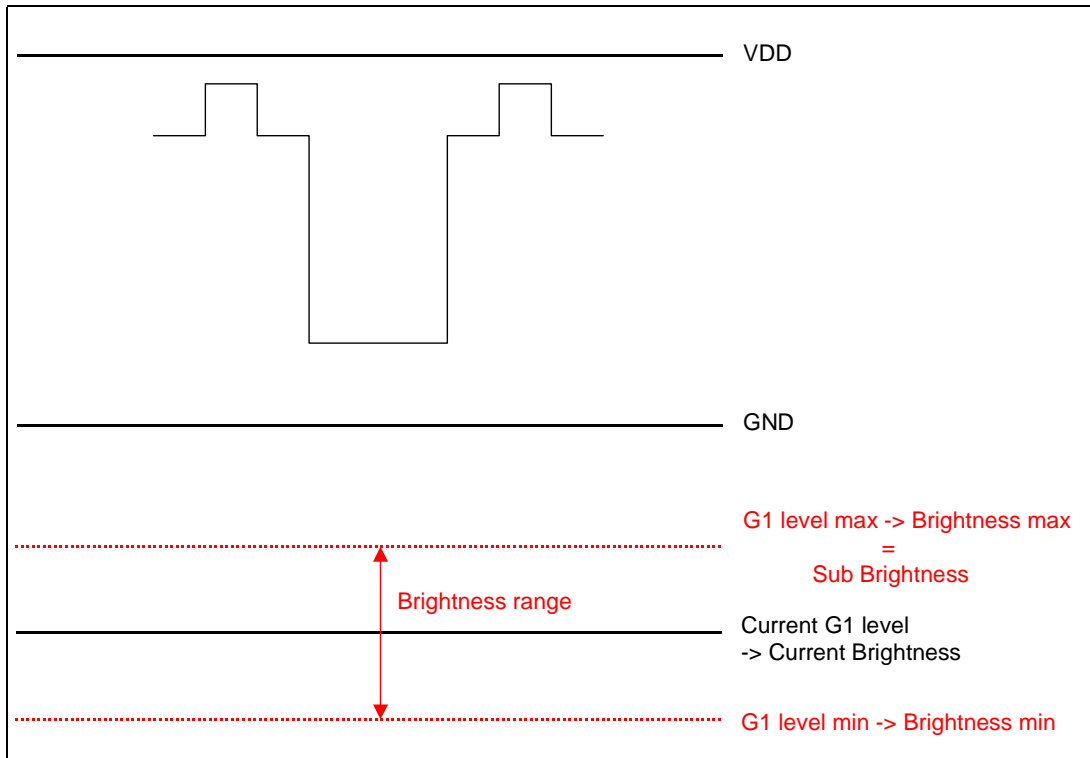

Note: When G1 controls brightness, $V_{G2}-V_{G1}$ decreases (respectively increases) when G1 increases (respectively decreases). Consequently, $V_{G2}-V_{G1}$ decreases (respectively increases) when brightness increases (respectively decreases).

Conclusion

For the same brightness level (for example 10V), the screen is brighter when preamplifiers control the brightness.

2.3 G1 level control

G1 level must be DAC-controlled.

Generally, G1 level is adjusted by DAC from the MCU (it can be any other I²C controlled DAC).

The DAC signal (from 0V to 5V typical) is amplified to reach the required G1 DC.

G1 frame blanking is coupled to G1 level by a capacitor (100nF typically)

Figure 3: G1 circuit schematic

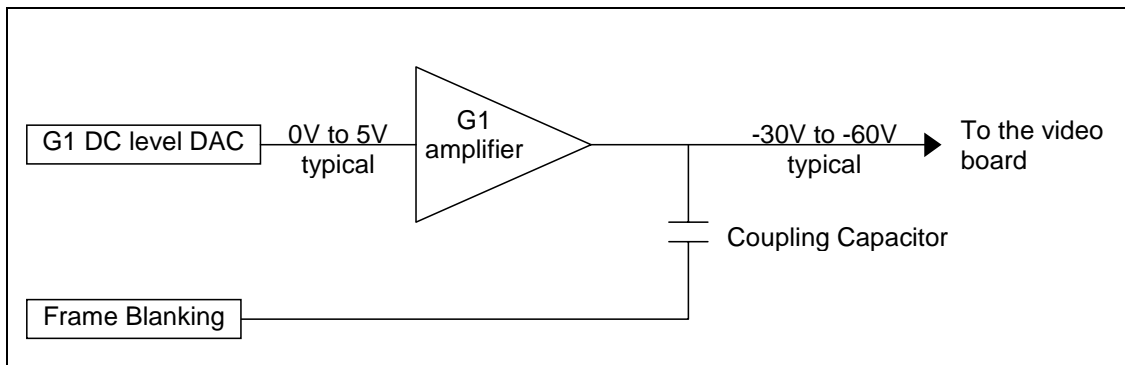

G1 amplifier is generally a network of resistors and one transistor.

3 Method 1- Brightness after drive, in preamplifier

3.1 Background

G1 is only used to adjust the sub-brightness (low luminance).

Brightness is controlled by preamplifier and is adjusted after drive.

With this method, tracking duration is short. After the tracking, the balance color changes with brightness.

3.2 Adjustment duration and performance

In the preamplifier, brightness is adjusted after drive, it does not depend on the drive.

Figure 4: Brightness after drive in preamplifier

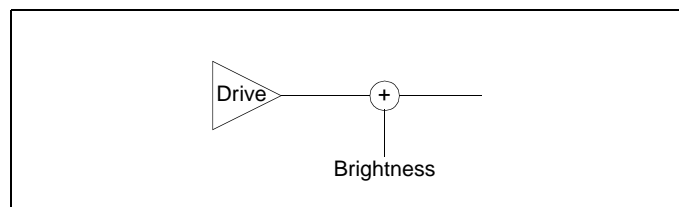

Changing the drive on a channel does not affect its black level: low luminance is unchanged when adjusting the color temperature in high luminance.

On the other hand, after the white balance tracking, the color temperature changes with brightness adjustment.

3.2.1 Tracking duration

Figure 5 shows the red cathode signal before and after color tracking in low luminance:

Figure 5: White balance tracking of black level

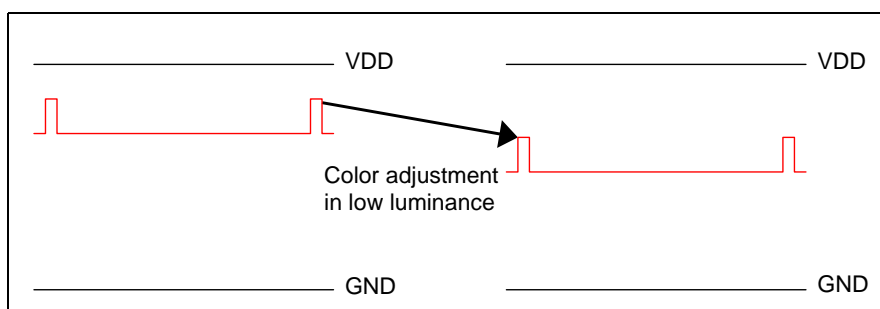
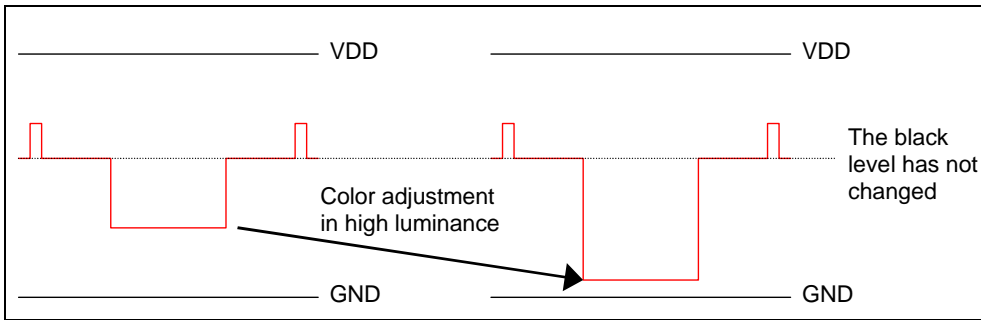

Figure 6 shows the red cathode signal before and after color tracking in high luminance.

Figure 6: White balance tracking of black level



Black level is unchanged: only one tracking in high and low luminance is necessary.

When brightness is after drive and controlled by the preamplifier, white balance tracking is short.

3.2.2 Tracking performance

Assuming that the white balance is reached with the following drive values: red drive = 25% and green drive = 50%, Figure 7 shows the red and green cathode signals with minimum brightness and 50% contrast.

Figure 7: Red and green cathode signals - 0% brightness, 50% contrast

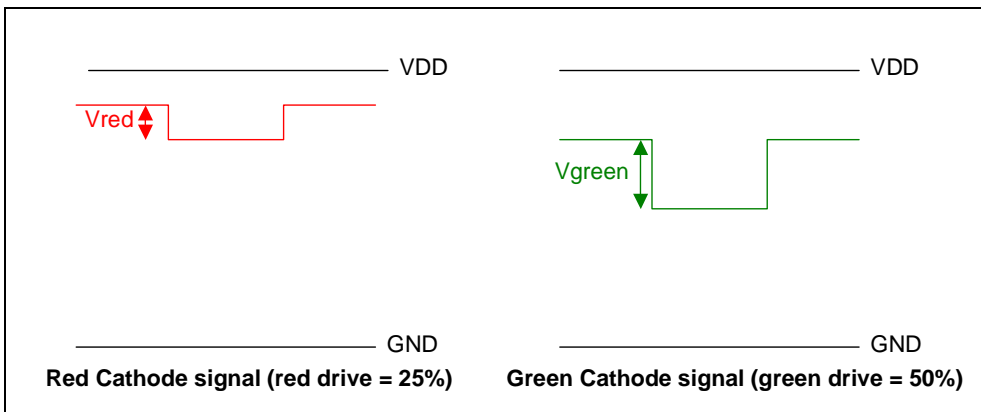

Assuming that $V_{red} = 10V$ (contrast • red drive) and $V_{green} = 20V$ (contrast green drive), the mathematical criteria for white balance is the ratio $V_{green}/V_{red} = 2$. *Figure 8* represents the setting with 100% contrast.

Figure 8: Red and green cathode signals - 0% brightness, 100% contrast

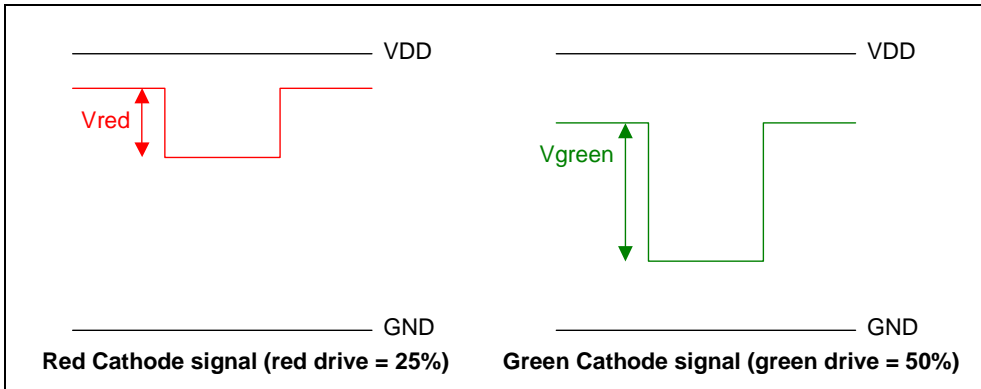

Contrast is proportional to the drive.

When $V_{red} = 20V$ (contrast • red drive) and $V_{green} = 40V$ (contrast • green drive), the ratio $V_{green}/V_{red} = 2$ is unchanged.

The white balance is reached for the contrast part of the video signal.

When brightness is after drive and controlled by the preamplifier, the color temperature does not change when changing the contrast.

Figure 9 shows the signals with 10V of brightness.

Figure 9: Red and green cathode signals with 10V brightness and 100% contrast

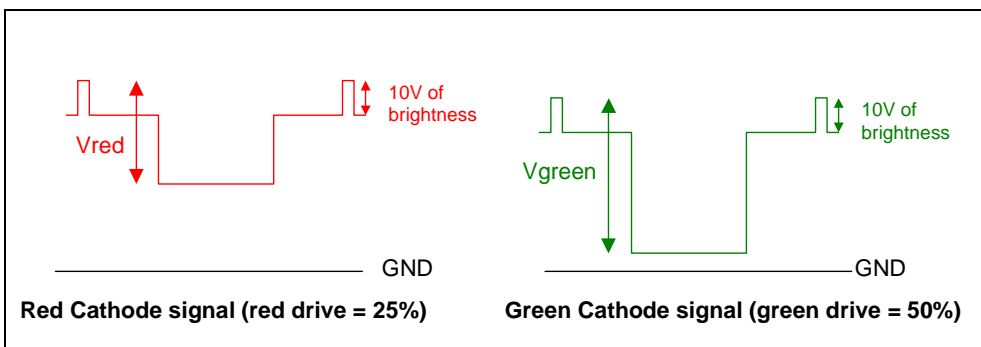

Brightness does not depend on the drive.

With $V_{red} = 30V$ (brightness + contrast • red drive) and $V_{green} = 50V$ (brightness + contrast • green drive), $V_{green}/V_{red} = 1.6$, the ratio has changed

The white balance is not reached for the brightness part of the video signal.

When brightness is after drive and controlled by the preamplifier, the color temperature changes when changing the brightness.

Conclusion

When brightness is after drive and controlled by the preamplifier, the color temperature remains unchanged with contrast adjustment but it is sensitive to brightness.

3.3 Black level area calculation

Each channel black level is set within the black level area:

- Black level above black level area: signal into the top non-linear area.
- Black level under black level area: signal into the bottom non-linear area.

Figure 10: Cathode signal areas (brightness by preamplifier)

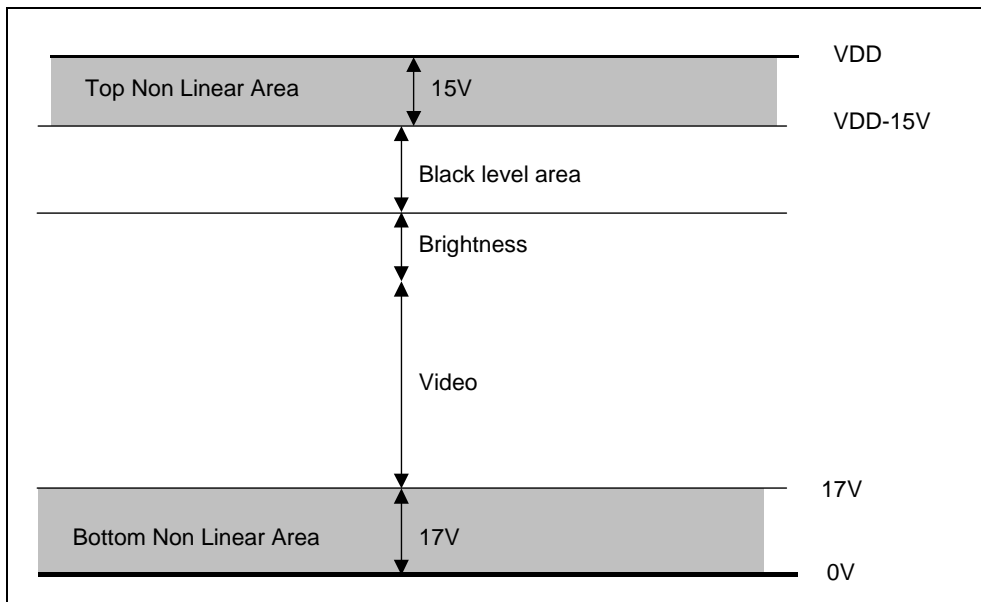

Black level area =

VDD – top non linear area (15V) – brightness – video – bottom non linear area (17V)

For instance, with the following requirements: VDD =100V, V_Brightness = 10V, V_Contrast = 40V

Black level area = 100 – 15 – 10 – 40 – 17 = 18V

The black area stands between 67V and 85V.

3.4 G1 DAC setting

Brightness is controlled by preamplifier, so the full range of G1 DAC is used to adjust the sub-brightness.

Figure 11: G1 DAC format, Brightness by preamplifier

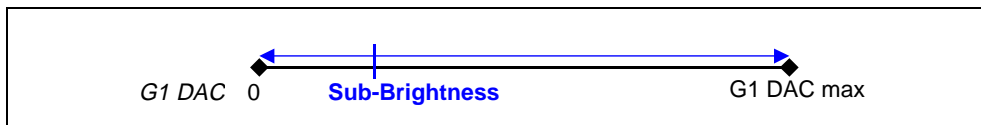

Set G1 DAC to its middle range as initial value.

3.5 STV9211 preamplifier software settings

3.5.1 Brightness is controlled by preamplifier (register 02)

The brightness DAC resolution is 8mV and the amplifier gain = 20.

Brightness DAC maximum value is $V_Brightness / (8mV * 20)$ which also corresponds to brightness DAC initial value.

For example, if $V_Brightness$ is 10V, brightness DAC maximum value is 63.

3.5.2 Brightness is after drive (Register 13)

Register 13 (bandwidth adjustment) bit 6 is set to 1: brightness after drive.

3.5.3 Infra-black offset setting (Register 14)

The infra black offset (register 14, Bit 1,2,3) value is set to avoid the video signal from going in the top non-linear zone, it is related to VDD value.

Table 1: Infrablack offset selection

VDD (+/- 5%)	Infra-black offset	
	Binary	Decimal
112 to 115V	001	1
107 to 111V	010	2
102 to 106V	011	3
97 to 101V	100	4
92 to 96V	101	5
88 to 91V	110	6
87 and below	111	7

Table 1 is indicative. For more efficient infra-black offset setting, the infra-black offset is adjusted with the cathode signals:

- Set the 3 infra-black level registers to 0 (register 10, 11, 12).
- Set brightness register to 0 (register 2).
- Put a probe on each amplifier output.
- Set infra black offset so that each video black level is at least at $VDD - 15V$ (top non linear area range).

3.5.4 Infra-black range setting (register 14)

Register 14 (bit 0) fixes R, G, B infra black level range and also the step of the R, G, B infra-black level DACs.

Table 2: Infra-black range selection

Infra black range	R, G, B infra-black level step at the cathode	R, G, B infra-black level range max at the cathode
0	140 mV	35.7 V
1	100 mV	25.5 V

Note: Do not set the infra black level registers with too high values otherwise the black level is below the black level area.

For instance, with the previous requirements ([Section 3.3](#)), and with infra-black range =1 (step=100mV), the infra-black level maximum value is:

$$\text{black level area/step} = 18\text{V}/100\text{mV} = 180.$$

3.5.5 Infra-black level settings (registers 10,11,12)

Set every infra-black level registers to 0 as initial values.

3.5.6 Drive setting (registers 3,4,5)

Drive register initial values must be as close as possible to *Y_high_lum* and (*x_target, y_target*) values for the fastest tracking. These values are determined during a manual white balance tracking in a reference monitor. Generally, initial drive values are equal and only related to *Y_high_lum*.

3.6 G2 setting

G2 is set by hardware on a reference monitor to reach $Y = Y_{low_lum}$ with the following conditions:

- Brightness in preamplifier = brightness initial value ([Section 3.5.1](#))
- No video (contrast = 1)
- R, G, B Infrablack level = 0 (minimum)
- Infra Black Offset = Infra Black Offset setting ([Section 3.5.3](#))
- G1 DAC = middle range

Note: check that the levels of G2, G1, and Video signal match the tube specification (especially the spot cut-off design chart).

3.7 White balance adjustment procedure

Initial condition:

- Initial G1 (G1 DAC) = middle range
- Initial contrast (preamp) = 1
- Initial brightness (preamplifier) = brightness initial value ([Section 3.5.1](#))
- Infra black-offset (preamplifier) = Infra black offset setting ([Section 3.5.3](#))
- Infra black-range (preamplifier) = infra black range setting ([Section 3.5.4](#))
- Initial Infra-black level (preamplifier) = 0
- Initial drive (preamplifier) = initial value of drive ([Section 3.5.6](#))

Table 3: Summary table and instructions - method 1

Step 1		Waveforms
Description	Preliminary adjustment: low luminance adjustment	
Pattern	full black	
Luminance	Y_{low_lum}	
Instructions	set contrast to 1 set brightness to initial value adjust sub brightness (G1) so that $Y=Y_{low_lum} \pm Y_{low_lum_tol}$	
Step 2		Waveforms
Description	Color adjustment in low luminance	
Pattern	full black	
Luminance	Y_{low_lum}	
Instructions	Adjust R, G, B Infra Black level to reach $x=x_{target} \pm x_{target_tol}$ and $y=y_{target} \pm y_{target_tol}$ Find the dominant color. The Infra Black level of this dominant color will be fixed. Increase the 2 others Infra Black levels to reach $x=x_{target} \pm x_{target_tol}$ and $y=y_{target} \pm y_{target_tol}$.	
Step 3		Waveforms
Description	Low luminance checking	
Pattern	full black	
Luminance	Y_{low_lum}	
Instructions	If Y is different from $Y_{low_lum} \pm Y_{low_lum_tol}$, adjust G1 (sub-brightness) to reach $Y=Y_{low_lum} \pm Y_{low_lum_tol}$	
Step 4		Waveforms
Description	Color checking in low luminance	
Pattern	full black	
Luminance	Y_{low_lum}	
Instructions	Go to step 2 if $x \neq x_{target} \pm x_{target_tol}$ and $y \neq y_{target} \pm y_{target_tol}$	
Step 5		Waveforms
Description	Brightness adjustment for high luminance (optional)	
Pattern	full black	
Luminance	0.06FL	
Instructions	Adjust brightness (Preamplifier) to reach $Y=0.06FL$	

Table 3: Summary table and instructions - method 1

Step 6		
Description	Color adjustment in high luminance	
Pattern	White box	
Luminance	Y_{high_lum}	
Instructions	<p>Set contrast to 255</p> <p>Adjust R, G, B Drive to reach $x=x_{target} \pm x_{target_tol}$ and $y=y_{target} \pm y_{target_tol}$:</p> <p>Find the dominant color. The Drive of this dominant color will be fixed.</p> <p>Increase the 2 others Drives to reach $x=x_{target} \pm x_{target_tol}$ and $y=y_{target} \pm y_{target_tol}$.</p>	
Step 7		
Description	High luminance checking	
Pattern	White box	
Luminance	Y_{high_lum}	
Instructions	<p>If Y is different from $Y_{high_lum} \pm Y_{high_lum_tol}$,</p> <p>adjust simultaneously R, G, B Drives to reach $Y = Y_{high_lum} \pm Y_{high_lum_tol}$.</p>	
Step 8		
Description	Color checking in high luminance	
Pattern	White box	
Luminance	Y_{high_lum}	
Instructions	Go to step 6 if $x \neq x_{target} \pm x_{target_tol}$ and $y \neq y_{target} \pm y_{target_tol}$	
Step 9		
Description	ABL setting	
Pattern	Full white	
Luminance	Y_{ABL}	
Instructions	Adjust ABL to reach $Y = Y_{ABL} \pm Y_{ABL_tol}$	

4 Method 2 - Brightness before drive, in preamplifier

4.1 Background

G1 only adjusts the sub-brightness (low luminance).

Brightness is controlled by preamplifier and brightness is before drive.

Tracking performances are very good: the color temperature is unchanged whatever the brightness or contrast. However, tracking duration is long.

4.2 Adjustment duration and performance

As brightness is before drive in the preamplifier, it is proportional to the drive.

Figure 12: Brightness before drive in preamplifier

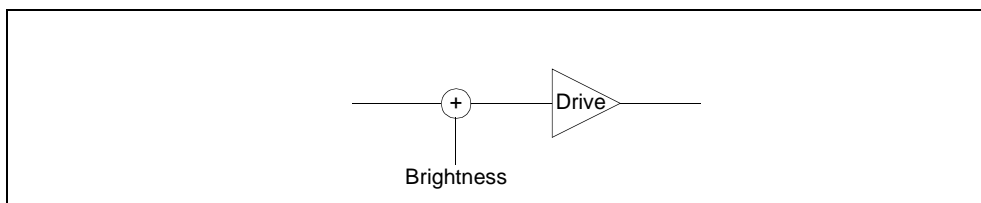

Following the white balance tracking, the color temperature is unchanged whatever the brightness or contrast. Especially, the color temperature in high luminance (white) does not change with brightness.

On the other hand, changing the drive on a channel affects its black level: the low luminance and color temperature in low luminance change when adjusting the color temperature in high luminance.

4.2.1 Tracking performance

Assuming that white balance is reached with the following drive values: red drive = 25% and green drive = 50%, [Figure 13](#) shows red and green cathode signals with minimum brightness.

Figure 13: red and green cathode signals with brightness minimum and contrast = 50%

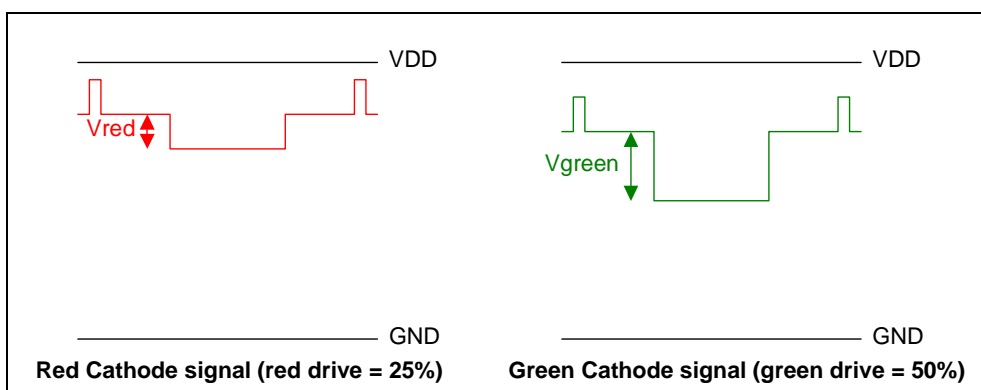

Assuming that $V_{red} = 10V$ (contrast • red drive) and $V_{green} = 20V$ (contrast • green drive), the mathematical criteria of white balance is the ratio $V_{green}/V_{red} = 2$.

Figure 14 shows the signals while setting the contrast to maximum.

Figure 14: red and green cathode signals with brightness = 0V and contrast = 100%

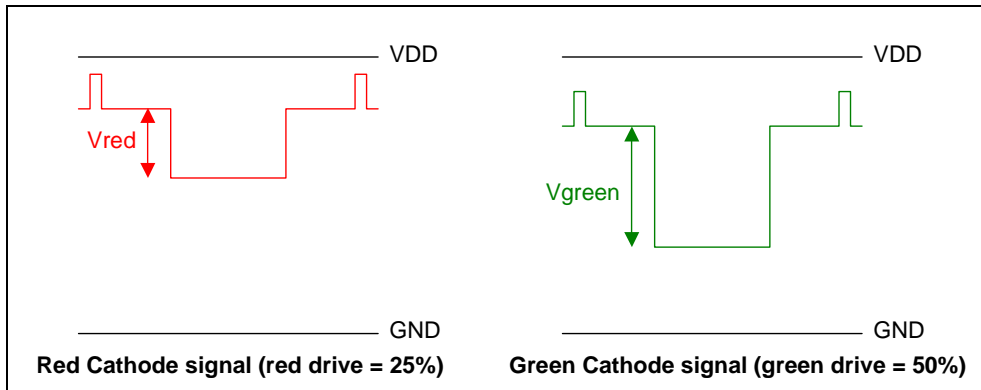

Contrast is proportional to the drive. $V_{red} = 20V$ (contrast • red drive) and $V_{green} = 40V$ (contrast • green drive), the ratio $V_{green}/V_{red} = 2$ has not changed.

The white balance is reached for the contrast part of the video signal.

When brightness is before drive and controlled by the preamplifier, the color temperature does not change with the contrast.

Figure 15 shows the resulting signals when adding 5V of brightness in red signal. Brightness being proportional to the drive, 10V of brightness has been added to the green signal ($10V \cdot 50\%/25\%$)

Figure 15: red and green cathode signals with 5V brightness and 100% contrast

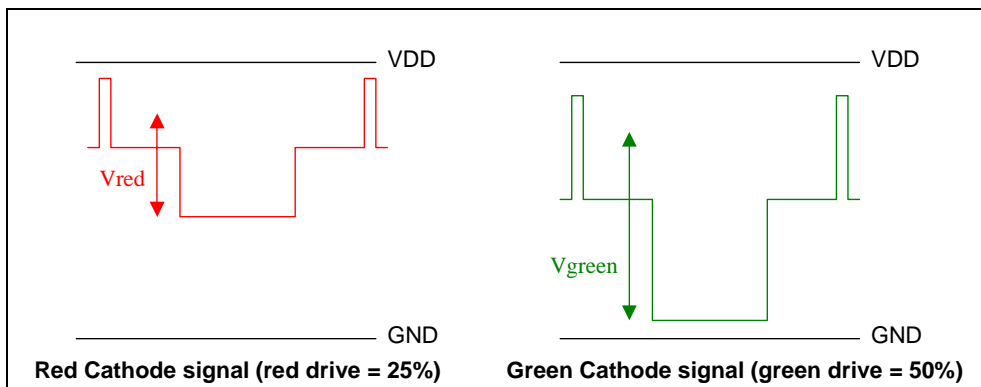

Brightness is proportional to the drive. $V_{red} = 30$ [(brightness + contrast) • red drive] and $V_{green} = 60$ [(brightness + contrast) • red drive], the ratio $V_{green}/V_{red} = 2$ has not changed.

The white balance is reached for the brightness part of the video signal.

When brightness is before drive and controlled by the preamplifier, the color temperature does not vary with brightness.

Conclusion

When brightness is before drive and controlled by the preamplifier, the color temperature does not change with brightness and contrast.

4.2.2 Tracking duration

Figure 16 shows the red cathode signal before and after color tracking in low luminance.

Figure 16: White balance tracking of black level

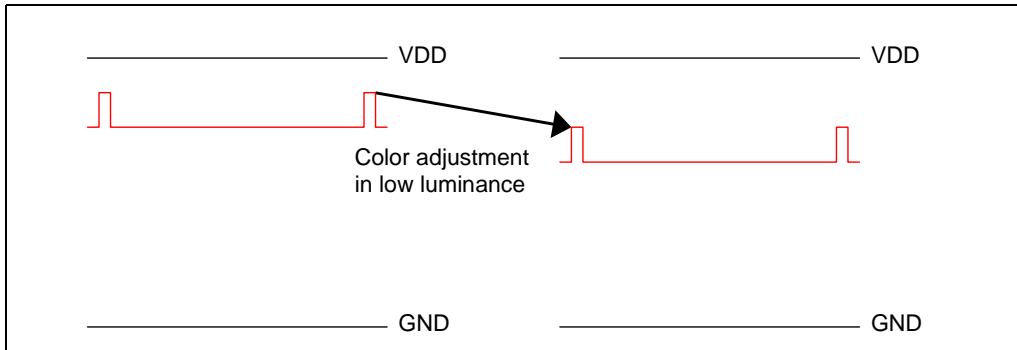
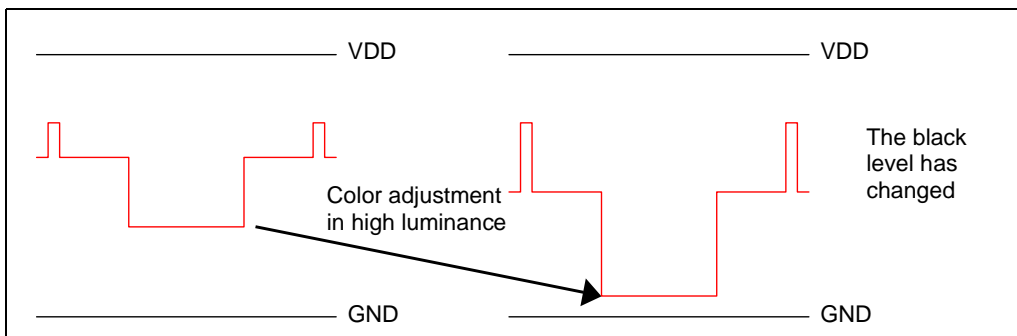

Figure 17 shows the red cathode signal before and after color tracking in high luminance.

Figure 17: White balance tracking of white level



Note: The black level has changed: a second tracking in low and high luminance is necessary. During the second high luminance adjustment, the black level does not change significantly.

Conclusion

When brightness is before drive and controlled by preamplifier, white balance tracking is long.

4.3 Black level area calculation

Each channel black level is set within the black level area:

- Black level above black level area: signal into the top non-linear area.
- Black level under black level area: signal into the bottom non-linear area.

Figure 18: Cathode signal areas (brightness by preamplifier)

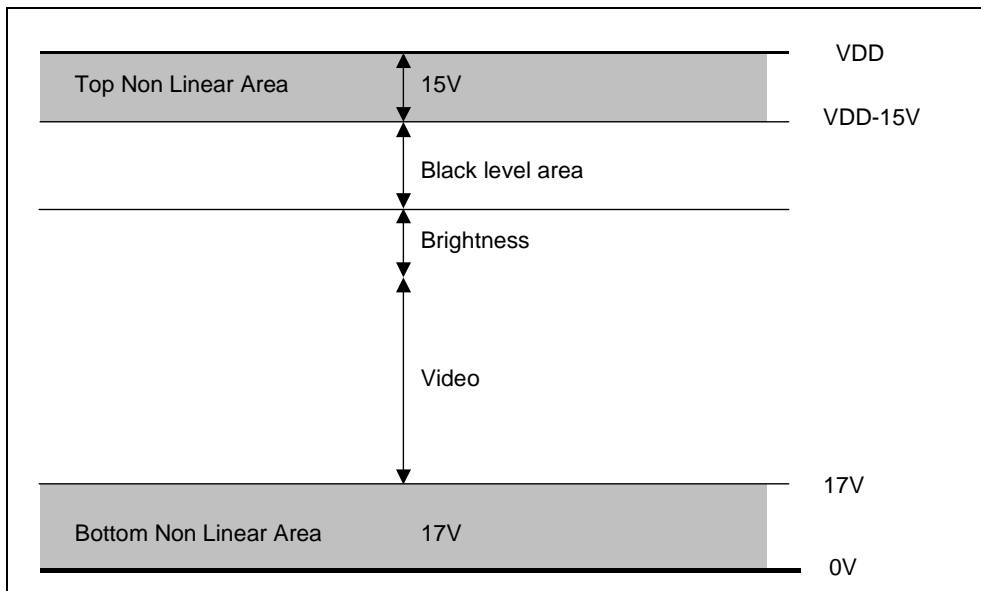

Black level area =

$$VDD - \text{top non linear area (15V)} - \text{brightness} - \text{video} - \text{bottom non linear area (17V)}$$

For instance, with the following requirements: $VDD = 100V$, $V_Brightness = 10V$, $V_Contrast = 40V$

$$\text{Black level area} = 100 - 15 - 10 - 40 - 17 = 18V$$

The black area stands between 67V and 85V.

4.4 G1 DAC setting

Brightness is controlled by preamplifier, G1 DAC full range is used to adjust the sub-brightness.

Figure 19: G1 DAC format, brightness by preamplifier

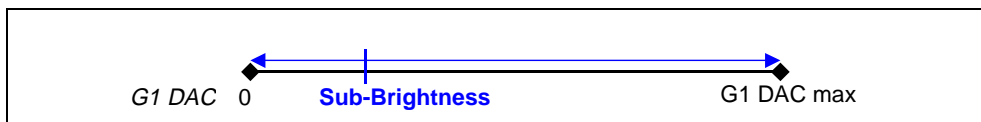

Set G1 DAC to its middle range as initial value.

4.5 Preamplifier STV9211 software settings

4.5.1 Brightness is controlled by preamplifier (register 02)

Brightness being proportional to the drive, brightness DAC resolution in a channel depends on this channel drive value.

The amplifier gain is 20.

The brightness maximum step (for drive =254) is $8\text{mV} \times 20 = 160\text{mV}$.

Brightness step = $160 \times (\text{drive value}/254)$ mV.

Brightness DAC maximum value is $V_Brightness / \text{brightness step}$.

For example, if $V_Brightness$ is 10V and drive = 127, the maximum value of brightness DAC is 125.

4.5.2 Brightness is before drive (register 13)

Set bit 6 of register 13 (bandwidth adjustment) to 0: brightness before drive.

4.5.3 Infra-black offset setting (register 14)

Set the infra-black offset (register 14 - bits 1,2,3) so that video signal does not go into the top non-linear zone.

This value depends on the VDD value:

Table 4: Infrablack offset selection

VDD (+/- 5%)	Infra-black offset	
	Binary	Decimal
112 to 115V	011	3
107 to 111V	100	4
102 to 106V	101	5
97 to 101V	110	6
92 to 96V	111	7
88 to 91V	111	7
87 and below	111	7

[Table 4](#) is indicative table. For more efficient infra-black offset setting, adjust the infra-black offset by checking the cathode signals:

- Set the 3 infra-black level registers to 0 (register 10, 11, 12).
- Set brightness register to 0 (register 2).
- Put a probe on each amplifier outputs.
- Set infra black offset so that each video black level is at least equal to $VDD - 15\text{V}$ (top non linear area range).

4.5.4 Infra-black range setting (register 14)

Bit 0 of register 14 fixes the range of the R, G, B infra-black level and also the step of the R, G, B infra-black level DACs.

Table 5: Infra Black range selection

Infra Black Range	R, G, B Infra Black level step at the cathode	R, G, B Infra Black level range max at the cathode
0	140mV	35.7V
1	100mV	25.5V

Remark

Make sure infra-black level registers values are not too high so that black level is not below the black level area ([Section 4.3](#)).

For instance, with the previous requirements from [Section 4.3](#) and with infra-black range =1 (step=100mV), the infra-black level maximum value is black level area/step = 18V/100mV = 180.

4.5.5 Infra-black level settings (register 10,11,12)

Set every infra-black level registers to 0 as initial values.

4.5.6 Drive setting (registers 3,4,5)

Set the drive register initial values as close as possible to Y_{high_lum} and (x_target, y_target) values for the fastest tracking.

These values are determined during a manual white balance tracking in a reference monitor.

Generally, the drive initial values are equal and determined to match only Y_{high_lum} .

4.6 G2 setting

G2 is set by hardware on a reference monitor to reach $Y = Y_{low_lum}$ with the following conditions:

- Brightness in preamplifier = brightness initial value ([Section 4.5.1](#))
- No video (contrast = 1)
- R, G, B infrablack level = 0 (minimum)
- Infra-black offset = Infra-black offset setting ([Section 4.5.3](#))
- G1 DAC = middle range

Note: check that G2, G1 levels and Video signal match the tube specification (especially the spot cut-off design chart).

4.7 White Balance Adjustment procedure

Initial condition:

- Initial G1 (G1 DAC) = middle range
- Initial contrast (preamp) = 1
- Initial brightness (preamplifier) = brightness initial value ([Section 4.5.1](#))
- Infra-black range (preamplifier) = infra-black range setting ([Section 4.5.4](#))
- Infra-black offset (preamplifier) = infra-black offset setting ([Section 4.5.3](#))
- Initial infra-black level (preamplifier) = 0
- Initial drive (preamp) = drive initial value ([Section 4.5.6](#))

Table 6: Summary table and instructions - method 2

Step 1		Waveforms
Description	Preliminary adjustment: low luminance adjustment	
Pattern	full black	
Luminance	Y_{low_lum}	
Instructions	set contrast to 1 set brightness to initial value adjust sub brightness (G1) so that $Y = Y_{low_lum} \pm Y_{low_lum_tol}$	
Step 2		Waveforms
Description	Color adjustment in low luminance	
Pattern	full black	
Luminance	Y_{low_lum}	
Instructions	Adjust R, G, B Infra Black level to reach $x = x_{target} \pm x_{target_tol}$ and $y = y_{target} \pm y_{target_tol}$ Find the dominant color. The Infra Black level of this dominant color will be fixed. Increase the 2 others Infra Black levels to reach $x = x_{target} \pm x_{target_tol}$ and $y = y_{target} \pm y_{target_tol}$.	
Step 3		Waveforms
Description	Low luminance checking	
Pattern	full black	
Luminance	Y_{low_lum}	
Instructions	If Y is different from $Y_{low_lum} \pm Y_{low_lum_tol}$, adjust G1 (sub-brightness) to reach $Y = Y_{low_lum} \pm Y_{low_lum_tol}$	
Step 4		Waveforms
Description	Color checking in low luminance	
Pattern	full black	
Luminance	Y_{low_lum}	
Instructions	Go to step 2 if $x \neq x_{target} \pm x_{target_tol}$ and $y \neq y_{target} \pm y_{target_tol}$	
Step 5		Waveforms
Description:	Brightness adjustment for high luminance (optional)	
Pattern	full black	
Luminance	0.06FL	
Instructions	Adjust brightness (Preamplifier) to reach $Y = 0.06FL$	

Table 6: Summary table and instructions - method 2

Step 6		
Description	Color adjustment in high luminance	
Pattern	White box	
Luminance	Y_high_lum	
Instructions	<p>Set contrast to 255</p> <p>Adjust R, G, B Drive to reach $x=x_{target} \pm x_{target_tol}$ and $y=y_{target} \pm y_{target_tol}$:</p> <p>Find the dominant color. The Drive of this dominant color will be fixed.</p> <p>Increase the 2 others Drives to reach $x=x_{target} \pm x_{target_tol}$ and $y=y_{target} \pm y_{target_tol}$.</p>	
Step 7		
Description	Luminance checking in high luminance	
Pattern	White box	
Luminance	Y_high_lum	
Instructions	<p>If Y is different from $Y_{high_lum} \pm Y_{high_lum_tol}$,</p> <p>adjust simultaneously R, G, B Drives to reach $Y = Y_{high_lum} \pm Y_{high_lum_tol}$.</p>	
Step 8		
Description	Color checking in high luminance	
Pattern	White box	
Luminance	Y_high_lum	
Instructions	Go to step 6 if $x \neq x_{target} \pm x_{target_tol}$ and $y \neq y_{target} \pm y_{target_tol}$	
Step 9		
Description	Second low and high luminance adjustment	
Instructions	Go to step 1 : one extra adjustment	
Step 10		
Description:	ABL setting	
Pattern	Full white	
Luminance	Y_ABL	
Instructions	Adjust ABL to reach $Y = Y_{ABL} \pm Y_{ABL_tol}$	

5 Method 3 - Brightness control by G1

5.1 Background

G1 is used to adjust sub-brightness and brightness.

Tracking duration is short however, the balance color changes with brightness after the tracking.

5.2 Adjustment duration and performance

Brightness is controlled by G1: the brightness versus drive behavior is the same as in [Chapter 3: method 1 - Brightness control by preamplifier and after drive](#).

As explained in [Chapter 3](#), the low luminance (and the color temperature) does not change when adjusting the color temperature in high luminance.

On the other hand, color temperature changes with the brightness after the white balance tracking.

5.2.1 Tracking duration

[Figure 20](#) shows the red cathode signal before and after the color tracking in low luminance.

Figure 20: White balance tracking of black level

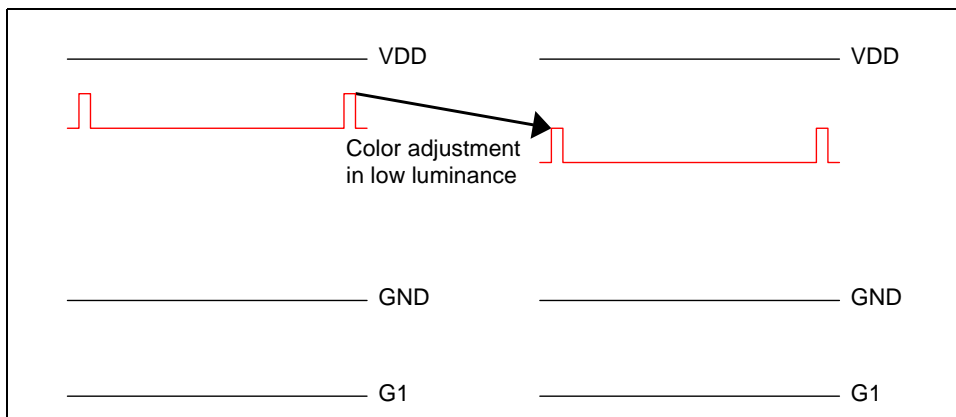
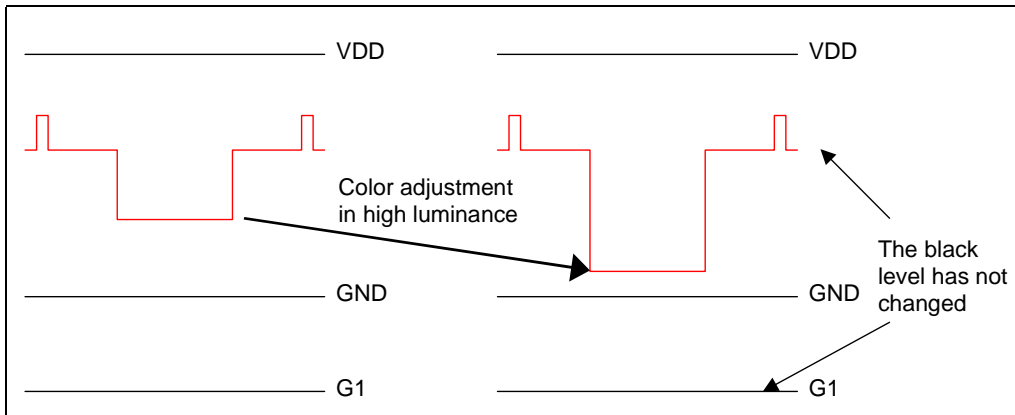

Figure 21 shows the red cathode signal before and after the color tracking in high luminance.

Figure 21: White balance tracking of white level



The black level does not change, only one tracking in high and low luminance is necessary.

When G1 controls the brightness, the white balance tracking is fast.

5.2.2 Tracking performance

We assume that the white balance is reached with the following drive values: red drive = 25% and green drive = 50%.

Figure 22 shows the red and green cathode signals with minimum brightness and 50% contrast.

Figure 22: red and green cathode signals with minimum brightness and 50% contrast

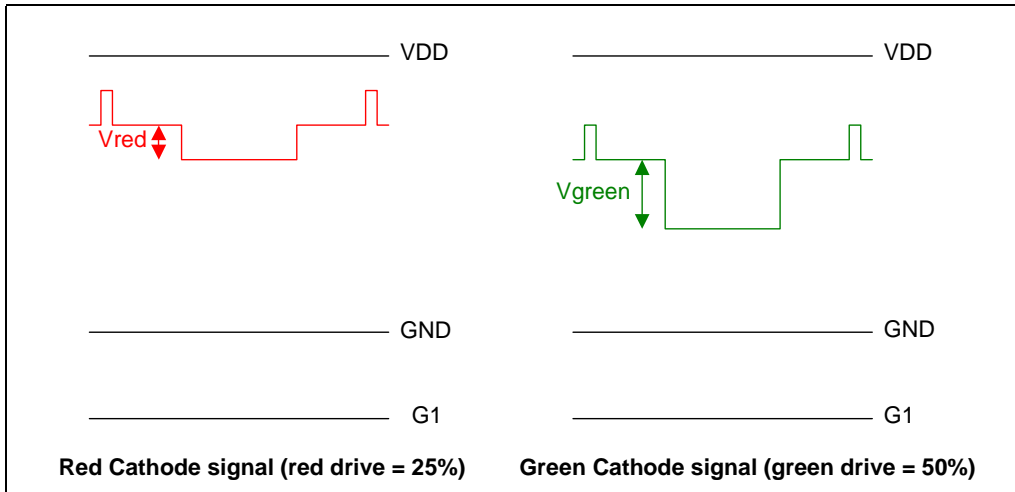

In the case where $V_{red} = 10V$ (contrast • red drive) and $V_{green} = 20V$ (contrast green drive), the mathematical criteria of white balance for the brightness part of the video signal is the ratio $V_{green}/V_{red} = 2$

Figure 23 shows the signals with 100% contrast.

Figure 23: red and green cathode signals with no brightness and 100% contrast

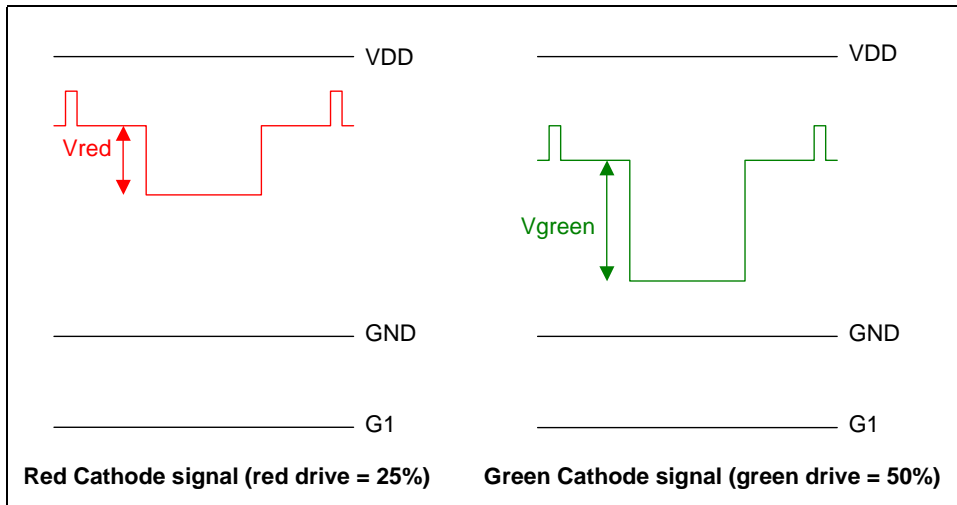

Contrast is proportional to drive.

$V_{red} = 20V$ (contrast • red drive) and $V_{green} = 40V$ (contrast • green drive), $V_{green}/V_{red} = 2$, the ratio has not changed.

The white balance is reached in the contrast part of the video signal.

When G1 controls the brightness, the color temperature does not change with contrast.

Figure 24 shows the signals resulting from the addition of 10V to brightness.

Figure 24: red and green cathode signals with 10V brightness and 100% contrast

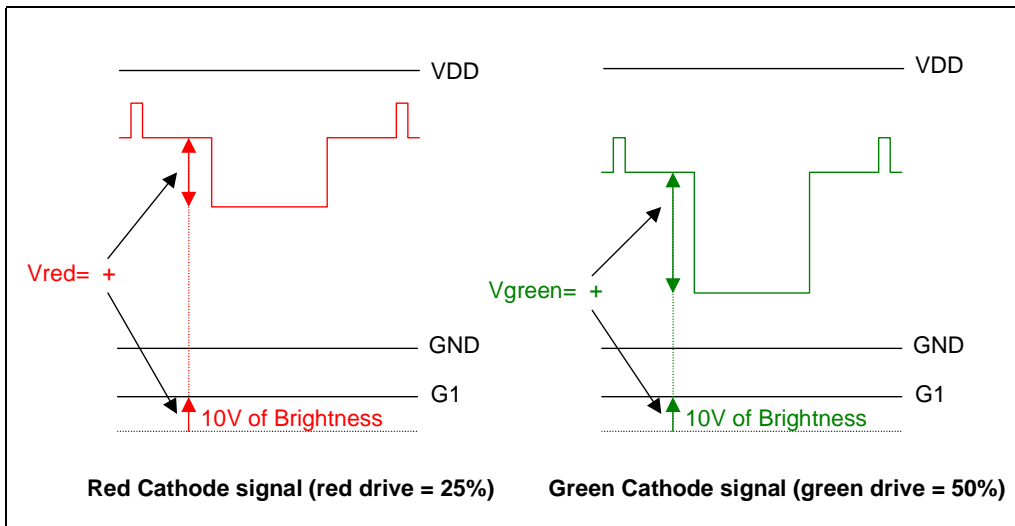

Then $V_{red} = 30V$ (brightness + contrast • red drive) and $V_{green} = 50V$ (brightness + contrast • green drive), $V_{green}/V_{red} = 1.6$, the ratio has changed.

The white balance is not reached in the brightness part of the video signal.

When G1 controls brightness, the color temperature varies with brightness adjustments.

Conclusion

When G1 controls the brightness, the color temperature does not change with contrast but it is sensitive to brightness adjustment.

5.3 Black level area calculation

Each channel black level is set within the black level area:

- Black level above black level area: signal into the top non-linear area.
- Black level under black level area: signal into the bottom non-linear area.

Figure 25: Cathode signal areas (brightness by preamplifier)

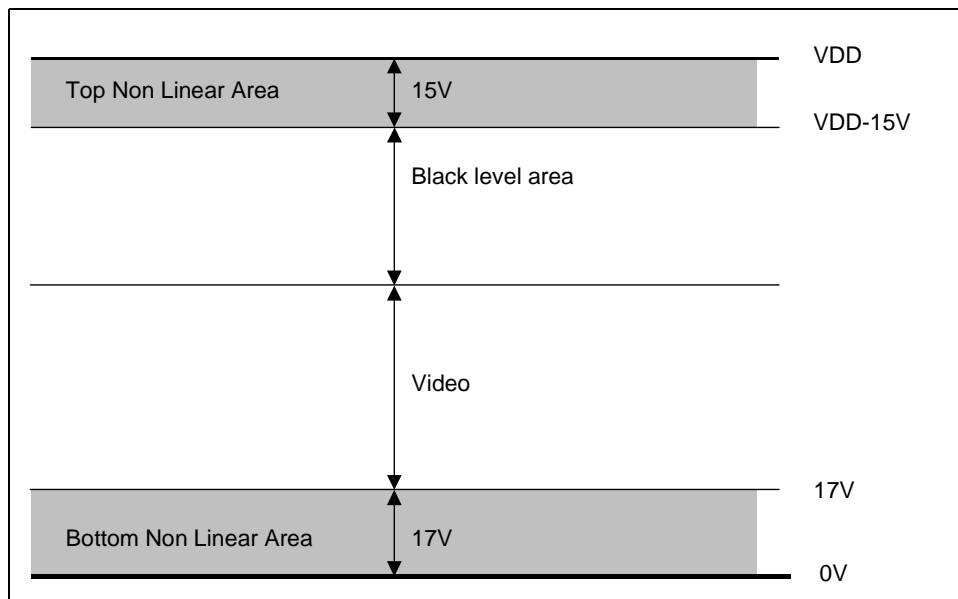

$Black\ level\ area = VDD - top\ non\ linear\ area\ (15V) - video - bottom\ non\ linear\ area\ (17V)$

For instance, with the following requirements: $VDD = 100V$, $V_Contrast = 40V$

$Black\ level\ area = 100 - 15 - 40 - 17 = 28V$

The black area stands between 57V and 85V.

5.4 G1 DAC setting

G1 controls brightness and sub-brightness.

One part of G1 DAC range is used for the brightness, the rest is used for sub-brightness.

Figure 26: G1 DAC format, brightness by G1

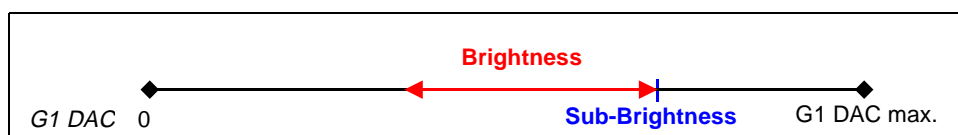

G1 DAC initial value calculation

Calculate the G1 DAC initial value by taking into account the brightness range.

The following example shows G1 DAC initial value calculation with typical values of brightness and sub-brightness ranges. We assume that G1 level increases with G1 DAC (the luminance increases with G1 DAC).

Table 7: G1 DAC setting values

G1 DAC length	G1 sub-brightness range	G1 brightness range	G1 min.	G1 max
255 bits	20V	10V	-40V	-10V

G1 total range is $20+10 = 30V$

G1 step is: $30V/255 = 118mV$.

The DAC range for brightness is then: $10/0.118 = 84$

So sub-brightness stands between 84 and 255:

Figure 27: G1 DAC format, brightness control by G1

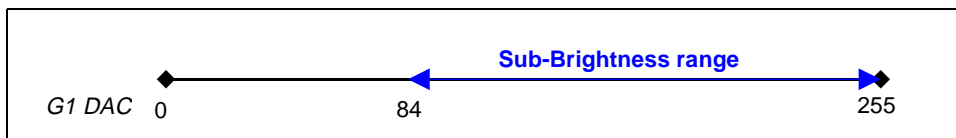

Then we have:

Table 8: Brightness range

DAC brightness range	min. DAC sub-brightness	max DAC Sub-brightness
84	84	255

The white balance adjustment determines the maximum brightness setting.

The low luminance adjustment initial value is set with the medium value of sub-brightness range:
 $255 - (171/2) = 171$

Set G1 DAC to 171 as initial value.

5.5 Preamplifier STV9211 software settings

5.5.1 Brightness control by G1

Set the preamplifier brightness DAC (register 2) to 0 and never change it.

5.5.2 Brightness (in preamplifier) after drive (register 13)

Set bit 6 of register 13 (Bandwidth adjustment) to 1: brightness after drive.

5.5.3 Infra Black Offset setting (Register 14)

Set the infra-black offset (register 14, bits 1,2,3) to the correct value so that the video signal is not in the top non-linear zone.

This value depends on *VDD* value.

Table 9: Infrablack offset selection

VDD (+/- 5%)	Infra-black offset	
	Binary	Decimal
112 to 115V	011	3
107 to 111V	100	4
102 to 106V	101	5
97 to 101V	110	6
92 to 96V	111	7
88 to 91V	111	7
87 and below	111	7

Table 9 is indicative. For more efficient infra-black offset setting, adjust the infra-black offset by checking the cathode signals:

- Set the 3 infra-black level registers to 0 (register 10, 11, 12).
- Put a probe on each amplifier outputs.
- Set the infra-black offset so that each video black level is at least equal to *VDD* – 15V (top non linear area range).

5.5.4 Infra-black range setting (register 14)

Infra-black range (register 14, bit 0) fixes the R, G, B infra-black level range, and also the step of the R, G, B infra black level DACs.

Table 10: Infrablack range selection

Infra-black range	R, G, B infra-black level step at the cathode	max R, G, B infra-black level range at the cathode
0	140mV	35.7V
1	100mV	25.5V

Avoid setting the infra-black level registers with too high values so that the black level is not below the black level area (*Section 5.3*).

For instance, with the previous requirements (*Section 5.3*), and with Infra-black range =1 (step=100mV), the maximum value of infra-black level will be:
black level area/step = 18V/100mV = 180.

5.5.5 Infra-black level settings (registers 10,11,12)

Set every infra-black level registers to 0 as initial values.

5.5.6 Drives setting (registers 3,4,5)

Set the drive register initial values as close as possible to Y_{high_lum} and (x_target, y_target) values for the fastest tracking.

Those values are determined during a manual white balance tracking in a reference monitor.

Generally, the initial drive values are equal and determined to match only Y_{high_lum} value.

5.6 G2 setting

G2 is set by hardware on a reference monitor to reach $Y = Y_{low_lum}$ with the following conditions:

- No video (contrast = 1)
- R, G, B Infrablack level = 0 (minimum)
- Infra Black Offset = Infra-black offset setting ([Section 5.5.3](#))
- G1 DAC = G1 DAC initial value ([Section 5.4](#))

Note: Check that the levels of G2, G1 and video signal match the tube specification (especially the spot cut-off design chart).

5.7 White balance adjustment procedure

Initial condition

- Initial G1 (G1 DAC) = G1 DAC initial value ([Section 5.4](#))
- Initial contrast (preamplifier) = 1
- Brightness (preamplifier) = 0
- Infra-black range (preamplifier) = infra-black range setting ([Section 5.5.4](#))
- Infra-black offset (preamplifier) = infra-black offset setting ([Section 5.5.3](#))
- Initial Infra-black level (preamplifier) = 0
- Initial drive (preamplifier) = drive initial value ([Section 5.5.6](#))

Table 11: Summary table and instructions - method 3

Step 1		<p style="text-align: center;">Waveforms</p>
Description	Preliminary adjustment: low luminance adjustment	
Pattern	full black	
Luminance	Y_low_lum	
Instructions	set contrast to 1 set brightness to initial value adjust sub brightness (G1) so that $Y=Y_{low_lum} \pm Y_{low_lum_tol}$	
Step 2		
Description	Color adjustment in low luminance	
Pattern	full black	
Luminance	Y_low_lum	
Instructions	Adjust R, G, B Infra Black level to reach $x=x_{target} \pm x_{target_tol}$ and $y=y_{target} \pm y_{target_tol}$ Find the dominant color. The Infra Black level of this dominant color will be fixed. Increase the 2 others Infra Black levels to reach $x=x_{target} \pm x_{target_tol}$ and $y=y_{target} \pm y_{target_tol}$.	
Step 3		
Description	Low luminance checking	
Pattern	full black	
Luminance	Y_low_lum	
Instructions	If Y is different from $Y_{low_lum} \pm Y_{low_lum_tol}$, adjust G1 (sub-brightness) to reach $Y = Y_{low_lum} \pm Y_{low_lum_tol}$	
Step 4		
Description	Color checking in low luminance	
Pattern	full black	
Luminance	Y_low_lum	
Instructions	Go to step 2 if $x \neq x_{target} \pm x_{target_tol}$ and $y \neq y_{target} \pm y_{target_tol}$	
Step 5		
Description	Brightness adjustment for high luminance (optional)	
Pattern	full black	
Luminance	0.06FL	
Instructions	Adjust brightness (Pre-amplifier) to reach $Y=0.06FL$	

Table 11: Summary table and instructions - method 3

Step 6		
Description	Color adjustment in high luminance	
Pattern	White box	
Luminance	Y_{high_lum}	
Instructions	<p>Set contrast to 255</p> <p>Adjust R, G, B Drive to reach $x=x_{target} \pm x_{target_tol}$ and $y=y_{target} \pm y_{target_tol}$:</p> <p>Find the dominant color. The Drive of this dominant color will be fixed.</p> <p>Increase the 2 others Drives to reach $x=x_{target} \pm x_{target_tol}$ and $y=y_{target} \pm y_{target_tol}$.</p>	
Step 7		
Description	High luminance checking	
Pattern	White box	
Luminance	Y_{high_lum}	
Instructions	<p>If Y is different from $Y_{high_lum} \pm Y_{high_lum_tol}$,</p> <p>adjust simultaneously R, G, B Drives to reach $Y=Y_{high_lum} \pm Y_{high_lum_tol}$.</p>	
Step 8		
Description	Color checking in high luminance	
Pattern	White box	
Luminance	Y_{high_lum}	
Instructions	Go to step 6 if $x \neq x_{target} \pm x_{target_tol}$ and $y \neq y_{target} \pm y_{target_tol}$	
Step 9		
Description	ABL setting	
Pattern	Full white	
Luminance	Y_{ABL}	
Instructions	Adjust ABL to reach $Y=Y_{ABL} \pm Y_{ABL_tol}$	

6 Comparison of the three methods

We assume the same sub-brightness range (20V) and G1 DAC size for the 3 methods.

Table 12: Advantages and drawbacks of the 3 methods

Method	Advantages	Drawbacks
Method 1		
Brightness after drive, controlled by preamplifier	Short tracking (Section 3.2.1) Small step of sub-brightness and brightness	Color temperature changes with brightness (Section 3.5.1) Small black level area (Section 3.3)
Method 2		
Brightness before drive, controlled by preamplifier	Same color temperature whatever the contrast or brightness (Section 4.2.1) Small step of sub-brightness and brightness	Long tracking (Section 4.2.2) Small black level area (Section 4.3)
Method 3		
Brightness controlled by G1	Short tracking (Section 5.2.1) Large black level area (Section 5.3)	Color temperature changes with brightness (Section 5.5.1) Large step of sub-brightness and brightness

Information furnished is believed to be accurate and reliable. However, STMicroelectronics assumes no responsibility for the consequences of use of such information nor for any infringement of patents or other rights of third parties which may result from its use. No license is granted by implication or otherwise under any patent or patent rights of STMicroelectronics. Specifications mentioned in this publication are subject to change without notice. This publication supersedes and replaces all information previously supplied. STMicroelectronics products are not authorized for use as critical components in life support devices or systems without express written approval of STMicroelectronics.

The ST logo is a registered trademark of STMicroelectronics

© 2002 STMicroelectronics - All Rights Reserved

STMicroelectronics GROUP OF COMPANIES

Australia - Brazil - Canada - China - Finland - France - Germany - Hong Kong - India - Israel - Italy - Japan - Malaysia - Malta - Morocco - Singapore - Spain - Sweden - Switzerland - United Kingdom - United States

www.st.com



LittleDiode supplies new, hard to find or obsolete electronic components and semiconductors all over the world.

With over two million different components listed you are sure to find the part you need.

Feel free to visit us today at our online store:

LittleDiode.com

Looking forward to providing you with the best possible service.