



---

**LOW-COST DOUBLE LI-ION BATTERY CHARGER  
USING ST6255C/ST6265C MCU**

---

by Microcontroller Division Applications

**DESCRIPTION**

In everyday life, more and more portable electronic appliances, such as mobile phones, are powered by rechargeable batteries with a requirement for high capacity, small size and low weight. Li-ion batteries have been widely used to support these kind of devices due to their superior capacity for a given size and weight.

This Application Note explains how to use the ST6255C 8-bit Microcontroller in a cost-effective battery charger for Li-ion batteries, as implemented in the Li-ion Battery Charger Demonstration Board. The design implemented on this Board is easily scaleable to other types of Li-ion batteries simply by changing the software parameters and primary input voltage/current.

The charger has two slots. The front one can be used to plug in a simple battery or a mobile phone with an internal battery. The rear slot is for plugging in a stand-alone battery. A pair of LEDs (green/red) are assigned to each slot to indicate the charge status.

The main target MCU is the ST6255C. Among other features, this microcontroller embeds an A/D converter, a PWM signal generator and 4K bytes of program memory, which is enough to embed the algorithm. The board also supports the ST6265C MCU, which adds 128 bytes of internal EEPROM to the features of the ST6255C.

The evaluation board is intended to be equipped with two mobile phone batteries and an ST6255C OTP sample to execute the demonstration software. The software parameters are adapted to a fixed battery capacity of 600 mAh. With minor modifications to the system, it is possible to make the charger read the battery capacity and change its parameters accordingly (feature not implemented on the evaluation board).

The board must be powered by an external low-voltage DC supply (6 V, 800 mA).

---

## Table of Contents

---

<b>DESCRIPTION</b> .....	<b>1</b>
<b>1 THEORY OF OPERATION</b> .....	<b>3</b>
<b>1.1 BATTERY CHARGING</b> .....	<b>3</b>
<b>1.2 SLOT PRIORITY</b> .....	<b>4</b>
<b>1.3 MAN-MACHINE INTERFACE</b> .....	<b>5</b>
<b>2 EVALUATION BOARD IMPLEMENTATION</b> .....	<b>6</b>
<b>2.1 CHARGING CIRCUITRY</b> .....	<b>6</b>
2.1.1 Charging Current Control .....	6
<b>2.2 PWM SIGNAL SWITCHING GENERATION</b> .....	<b>7</b>
2.2.1 Measurement Circuitry .....	9
2.2.2 Battery Discharge Protection .....	9
2.2.3 Power Supply Restrictions .....	9
<b>2.3 TEMPERATURE SENSING AND BATTERY DETECTION</b> .....	<b>10</b>
<b>2.4 MCU SOFTWARE</b> .....	<b>11</b>
2.4.1 Architecture .....	11
2.4.2 On-chip peripherals usage .....	13
2.4.3 State Diagrams .....	14
2.4.4 Slot Monitor Flowchart .....	17
2.4.5 Source File Organisation .....	23
<b>3 CONCLUSION: A LOW-COST FLEXIBLE SOLUTION</b> .....	<b>24</b>
<b>4 APPENDIX</b> .....	<b>25</b>
<b>4.1 SCHEMATIC</b> .....	<b>25</b>
<b>4.2 BILL OF MATERIAL</b> .....	<b>26</b>

## 1 THEORY OF OPERATION

### 1.1 BATTERY CHARGING

Li-ion batteries have a very different charging procedure from NiCd or NiMH batteries. Li-ion batteries should be charged using two different methods (Figure 1.), constant voltage and constant current.

**Figure 1. Li-ion Charging Method**

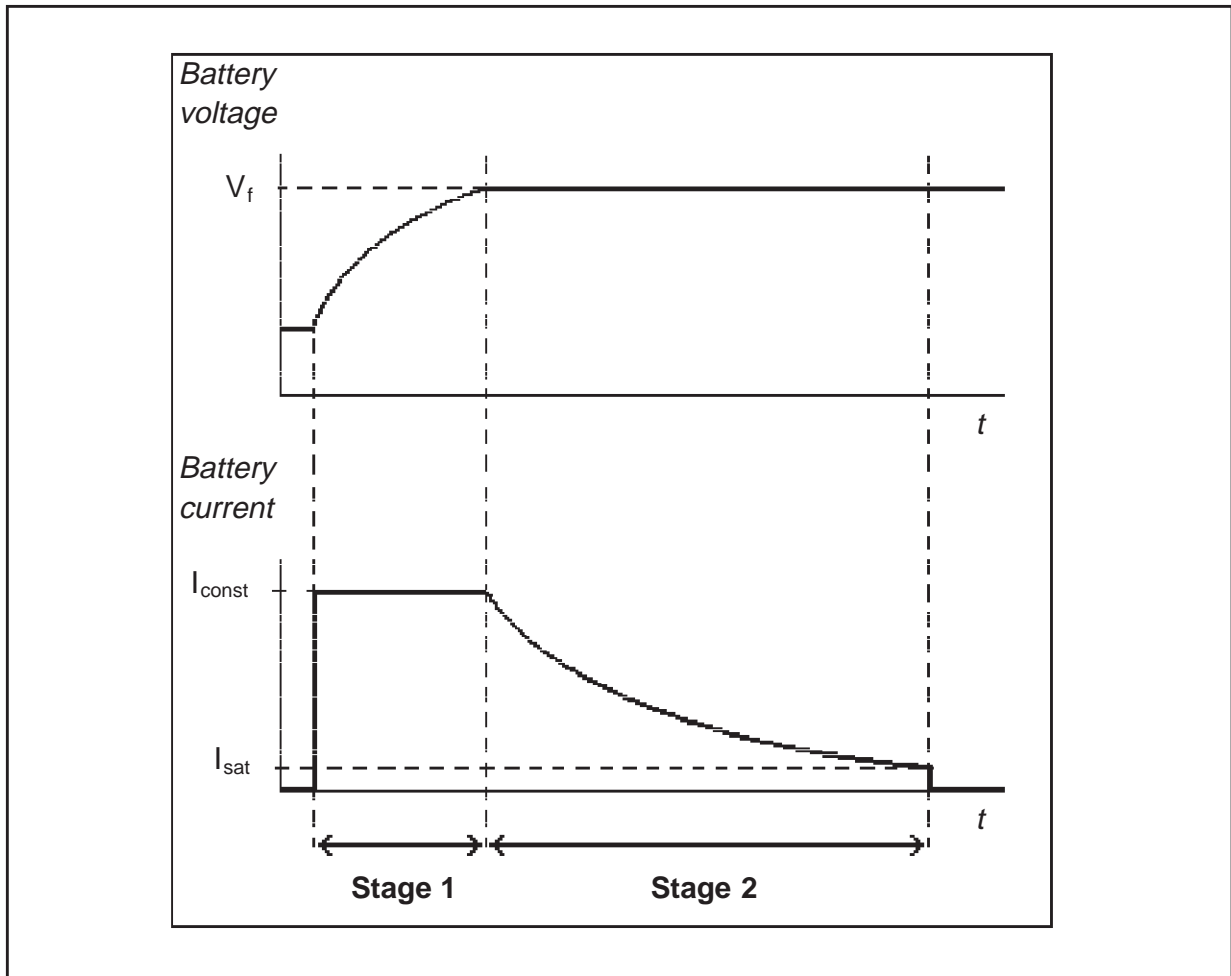

During Stage 1 (constant current charge), the charging current is kept at a constant value ( $I_{const}$ ) until the battery voltage reaches the final cell voltage ( $V_f$ ). Note that the battery could suffer significant damage if this final voltage is exceeded. Then, in Stage 2 (constant voltage charge), the voltage is kept constant within this limit by slowly decreasing the current. Charging is stopped when the current drops below the manufacturer fixed threshold value ( $I_{SAT}$ ). This current indicates that the battery is saturated.

## LOW-COST DOUBLE LI-ION BATTERY CHARGER USING ST6255C/ST6265C MCU

If the battery voltage drops below a certain threshold ( $V_{FAST}$ ), a fast charge is applied. During fast charging, the current is kept constant at  $I_{FAST} > I_{CONST}$ .

After a certain time ( $t_{FAIL}$ ) of fast charging, and if battery voltage remains particularly low (under  $V_{FAIL}$ ), the charger indicates a battery failure and stops charging. If the battery voltage is even lower (below  $V_{SC}$ ), the charger indicates a battery failure without waiting (protection against short-circuit).

If the charging time exceeds a certain expiration value ( $t_{EXP}$ ), charging is stopped even if the battery is not yet saturated. As the  $t_{EXP}$  value is greater than the  $t_{FAIL}$  value, the charger indicates that the battery is in good condition and fully charged.

The battery temperature is also monitored. If the battery overheats, charging is suspended until the battery cools down.

Once the battery is saturated, its voltage is still monitored to prevent the battery from discharging completely. If the battery voltage drops below  $V_{TRI}$ , charging restarts until  $V_F$  is reached again. Charge time is reset when trickle charging starts.

**Table 1. Charge Parameters used by the Evaluation Board**

Symbol	Meaning	Value	Unit
$V_F$	Final Battery Voltage	4.2	V
$V_{TRI}$	Trickle Charge Voltage	4.12	
$V_{FAST}$	Fast Charge Voltage	3.8	
$V_{FAIL}$	Battery Failure Voltage	2.5	
$V_{SC}$	Short-circuit Voltage	1.5	
$I_{FAST}$	Fast Charge Current	600	mA
$I_{CONST}$	Constant Charge Current	550	
$I_{SAT}$	Battery Saturation Current	15	
$t_{FAIL}$	Battery Failure Time	30	s
$t_{EXP}$	Charge Expire Time	2.5	h

### 1.2 SLOT PRIORITY

Battery presence in both slots is permanently monitored to implement the priority of the front slot over the rear slot. Whenever a battery is plugged into the front slot while the rear slot battery is being charged, rear charging is stopped and front charging begins. When front charging is terminated (battery saturated, expire time reached, battery failure or battery removed), rear charging restarts from the beginning.

If the front battery requires trickle charging, rear battery full charging has the priority. If both batteries are saturated, the first battery to meet the trickle charge condition is charged, and then the second one. If both batteries meet trickle charge conditions at the same time, front slot has the priority.

Priority rules are not changed even if charging is suspended because of overheating.

### 1.3 MAN-MACHINE INTERFACE

As the charger periodically checks battery presence, no button is needed to start or stop charging.

A reset button is included on the evaluation board for development purposes.

A pair of LEDs (green/red) are dedicated to each slot to indicate the charge status.

**Table 2. LED Slot Status Color Code**

Color	Status
Off	No battery in the slot OR Rear charge stopped by front charge
Red only	Battery under charge
Red and green	Overheat
Green only	Charge cycle completed
Flashing red	Battery failure

## 2 EVALUATION BOARD IMPLEMENTATION

### 2.1 CHARGING CIRCUITRY

The evaluation board implements a solution with an *external* low-voltage DC supply, unlike the solutions described in other Battery Charger Application Notes.

To obtain a constant voltage during one stage and a constant current during another, the ST6 measures the battery voltage ( $V_{BAT}$ ) and current ( $I_{BAT}$ ). With this feedback, it regulates the charging voltage using a buck converter circuit (Figure 2.):

**Figure 2. Schematic of PWM Control of Battery Charging**

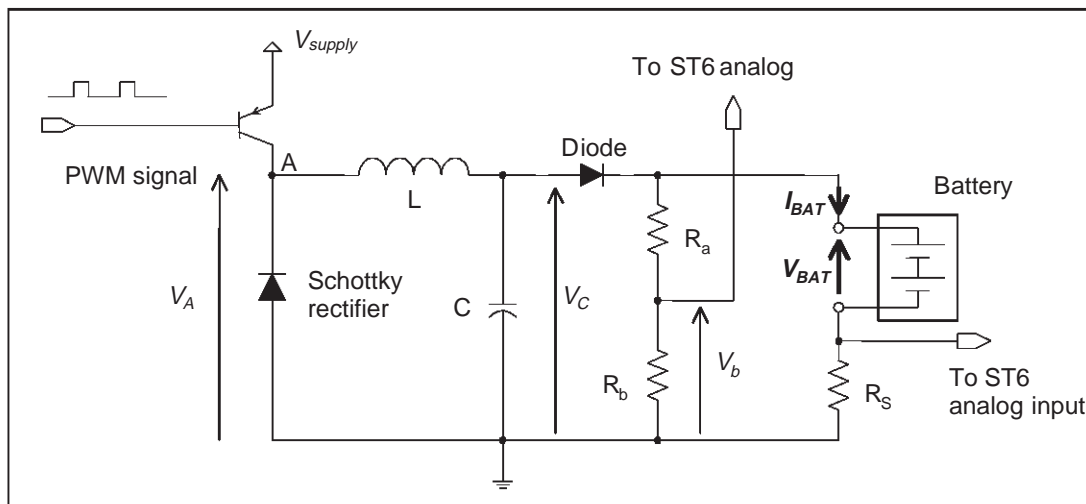

#### 2.1.1 Charging Current Control

The PWM signal generated by the ST6255C switches the PNP transistor on and off. A Schottky rectifier is needed to receive the current from the coil when the PNP transistor is off (free-wheeling mechanism). As a result, the PWM signal is transferred to the node A voltage:

- when the transistor is on,  $V_A = V_{SUPPLY} - |V_{CE}|_{SAT}$  and the rectifier is off;
- when the transistor is off, the rectifier is on and  $V_A = -V_d$ .

$|V_{CE}|_{SAT}$  is the collector-emitter voltage of the PNP transistor in saturation state.  $V_d$  is the forward voltage drop of the Schottky rectifier.

Let us first consider a small period of time, e.g. ~100 PWM cycles.

Battery voltage variations are far slower than PWM switching, so  $V_{BAT}$  can be considered as constant during this period. With this approximation,  $V_C$  can be seen as the response of the LC network to the incoming PWM signal  $V_A$ . The network acts as a low-pass filter. Therefore, if the PWM frequency is far higher than cut-off frequency,  $V_C$  is constant and equal to the mean value of  $V_A$ .

In this demo,  $L = 150 \mu\text{H}$  and  $C = 220 \mu\text{F}$  so the cut-off frequency is 876 Hz. The PWM frequency is fixed at  $\sim 30 \text{ kHz}$ . This way, charging voltage ripple is minimized.

If  $\alpha$  is the PWM positive duty cycle in A, the mean value of  $V_A$  is  $\alpha \cdot (V_{\text{SUPPLY}} - |V_{\text{CE}}|_{\text{SAT}}) + (1 - \alpha) \cdot (-V_d)$ . Accordingly, the charging current is:

$$I_{bat} = \frac{\alpha \cdot (V_{supply} - |V_{CE}|_{sat}) + (1 - \alpha) \cdot (-V_d) - V_D - V_{bat}}{R_S}$$

Where  $V_D$  is the forward voltage of the diode.

Example with the evaluation board hardware:

For the maximum current to apply (600 mA), typical values are:

$$|V_{\text{CE}}|_{\text{SAT}} = 0.5 \text{ V},$$

$$V_d = 0.4 \text{ V},$$

$$V_D = 0.9 \text{ V}.$$

In fast charge mode,  $I_{\text{BAT}} = 600 \text{ mA}$  and the maximum battery voltage is 3.8 V. This requires a duty cycle of  $\sim 92\%$ . In constant current charge mode,  $I_{\text{BAT}} = 550 \text{ mA}$  and the maximum battery voltage is 4.2 V. In this case, the required duty cycle is  $\sim 98\%$ . These values show that the range of duty cycles is fully used, which improves PWM resolution.

Let us now consider the whole charging time. At this scale,  $\alpha$ ,  $I_{\text{BAT}}$  and  $V_{\text{BAT}}$  are not constant. The above equation helps to understand how  $\alpha$  evolves during this time.

During the 1<sup>st</sup> charge stage,  $V_{\text{BAT}}$  increases, so the MCU increases  $\alpha$  in order to keep  $I_{\text{BAT}}$  constant. During the 2<sup>nd</sup> stage,  $\alpha$  decreases gradually in order to reduce  $I_{\text{BAT}}$ , but this does not decrease  $V_{\text{BAT}}$ .

### 2.2 PWM SIGNAL SWITCHING GENERATION

The ST6255C only provides one PWM signal. Switching the signal from one slot to another is done through the E\_FRONT and E\_REAR signals, generated by standard output pins. It is less expensive to implement the AND function using NPN transistors than with AND gates.

Figure 3. PWM Signal Generation Circuit

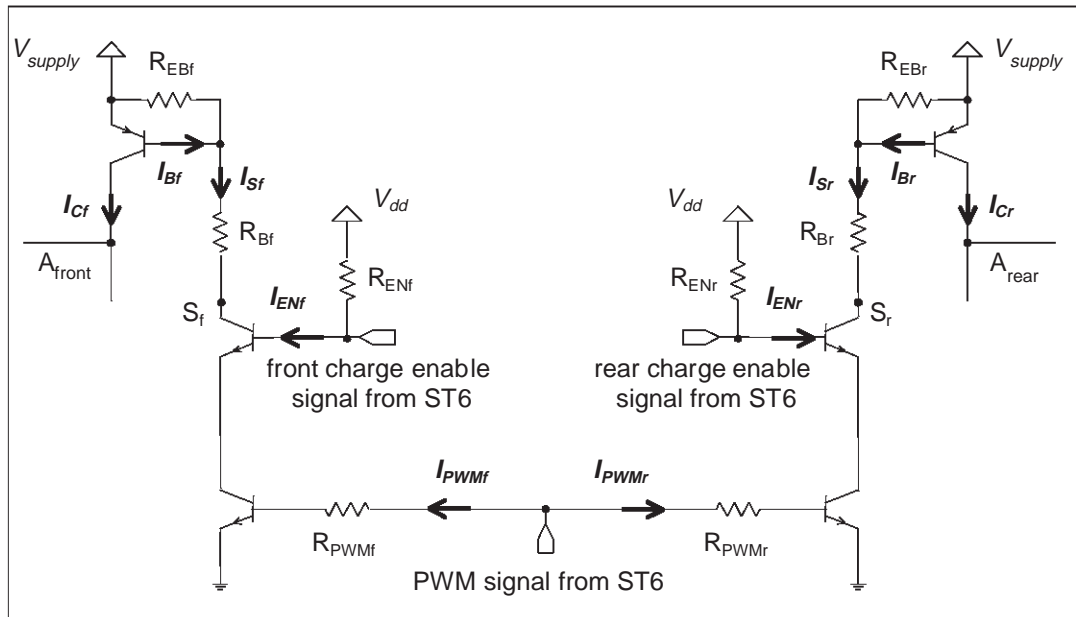

Selecting the proper power PNP transistor is not enough to make sure the buck converter can actually output the maximum current. The driving resistors ( $R_{EB}$ ,  $R_B$ ,  $R_{EN}$  and  $R_{PWM}$ ) should also be chosen accordingly.

- When the PNP is on,  $|V_{CE}|$  should be as small as possible to minimise losses. This requires to be in saturation state, with a high base current. This current is equal to:

$$I_B = \frac{V_{supply} - |V_{BE}| - V_{SON}}{R_B} - \frac{|V_{BE}|}{R_{EB}}$$

$|V_{BE}|$  is the base-emitter voltage of the PNP.  $V_{SON}$  is the node S voltage when both NPNs are on. It equals the sum of saturation collector-emitter voltages for the 2 NPNs.

$R_{BE}$  and  $R_B$  guarantee that  $I_C/I_B \leq 10$  even if  $I_C$  is at its maximum.

Example with the evaluation board hardware:

At maximum collector current ( $I_C = 600 \text{ mA}$ ),  $|V_{BE}| = 0.9 \text{ V}$  typically.

At  $I_S \sim 60 \text{ mA}$ ,  $V_{SON} = 0.2 \text{ V}$ .

$R_{EB} = 270 \Omega$  and  $R_B = 75 \Omega$  meet the requirements (and then  $I_S = 65 \text{ mA}$ ).

- When on, the NPN transistors must also be in saturation state.

$R_{EN}$  makes sure that  $I_S/I_{EN} \leq 10$  even for the maximum value of  $I_S$ . E\_FRONT and E\_REAR

ST6 pins are open-drain outputs, so

$$I_{EN} = \frac{V_{dd} - (V_{BE})_{sat} - (V_{CE})_{sat}}{R_{EN}}$$

Here, unlike previous equations,  $(V_{BE})_{SAT}$  and  $(V_{CE})_{SAT}$  refer to the NPN transistor values.  $R_{PWM}$  guarantees that  $(I_S + I_{EN})/I_{PWM} \leq 10$  even if  $(I_S + I_{EN})$  is maximum.

$$I_{PWM} = \frac{V_{oh} - (V_{BE})_{sat}}{R_{PWM}}$$

$V_{oh}$  is the output high voltage of the ST6 pin emitting the PWM signal.

Example with the evaluation board hardware:

At maximum current ( $I_S = 65$  mA), typical values are  $(V_{BE})_{SAT} = 0.9$  V and  $(V_{CE})_{SAT} = 0.1$  V. For  $I_{PWM} = 7$  mA,  $V_{OH} = 4$  V typically (cf. ST6 datasheet).

$R_{EN} = 620 \Omega$  and  $R_{PWM} = 430$  meet the requirements.

### 2.2.1 Measurement Circuitry

A shunt ( $R_S$ ) is connected to the battery in order to measure the charging current. The MCU reads the  $V_S$  voltage with its on-chip A/D converter. The converter has a voltage range between ground and  $V_{DD}$ . When  $V_S$  is too low, like in this case, an amplification circuit is needed, e.g. with an OpAmp.

In our case,  $V_{supply} = 6$  V and the microcontroller is supplied with  $V_{DD} = 5$  V. Therefore, it is safer not to read  $V_{bat}$  directly, but to attenuate this voltage by using a resistor bridge ( $R_a$ ,  $R_b$ ). However, this attenuation must not be too strong to take maximum profit of the whole ADC input range (0 to  $V_{DD}$ ). This must be taken into account when choosing a proper  $R_a/R_b$  ratio.

Note that the ST6 does not measure  $V_{BAT}$  but  $V_B$ , which is proportional to  $(V_{BAT} + R_S \cdot I_{BAT})$ . Some calculation must be performed on the conversion results to access the real battery voltage.

### 2.2.2 Battery Discharge Protection

If the charger is not powered on or if the battery is already fully charged, the PNP transistor is kept permanently off. The diode prevents the battery from discharging into the capacitor. Therefore, the battery discharges into  $R_A$ ,  $R_B$  and  $R_S$ , which requires less current.

### 2.2.3 Power Supply Restrictions

The battery characteristics have a direct influence on the choice of the DC power supply:

- The supply must be able to drive enough current to charge the battery, even in fast charge mode.

## LOW-COST DOUBLE LI-ION BATTERY CHARGER USING ST6255C/ST6265C MCU

–  $V_{\text{SUPPLY}}$  must be larger than  $(|V_{\text{CE|SAT}} + V_{\text{D}} + V_{\text{FAST}} + R_{\text{S}} \cdot I_{\text{FAST}})$  and larger than  $(|V_{\text{CE|SAT}} + V_{\text{D}} + V_{\text{F}} + R_{\text{S}} \cdot I_{\text{CONST}})$ , but does not need to be significantly larger.

MCU, LED and OpAmp consumption must be taken into account as well.

The board is designed to work with a DC supply providing 6 V and 800 mA.  $V_{\text{DD}} = 5 \text{ V}$  is generated from  $V_{\text{SUPPLY}}$  by a voltage regulation circuit. If you intend to increase  $V_{\text{SUPPLY}}$ , make sure you adapt this regulation circuit.

### 2.3 TEMPERATURE SENSING AND BATTERY DETECTION

The Li-Ion battery used in this demo contains a thermistor connected to the negative pole, as described in Figure 4.

**Figure 4. Temperature Sensing Circuitry**

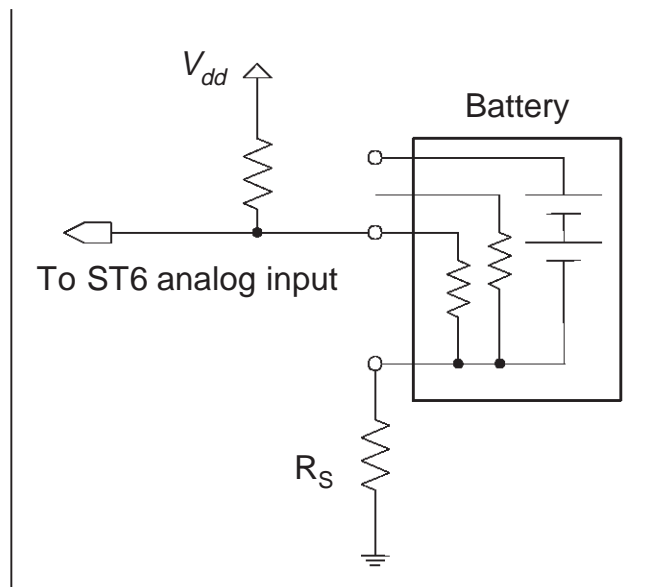

When the slot is empty (no battery plugged in), the ST6 reads  $V_{\text{DD}}$  on the analog input. Thus, a low value of the voltage indicates that a battery is present.

The thermistor resistance decreases with temperature, and so does the thermistor voltage. Therefore, an anomalously low value of this voltage indicates overheating.

Figure 5. Thermistor Voltage Indication

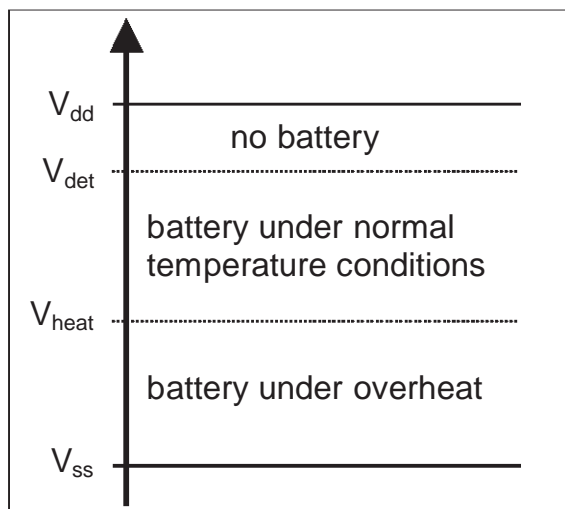

Table 3. Thermistor Voltage Thresholds used by the Evaluation Board

Symbol	Meaning	Value	Unit
$V_{DET}$	Battery Detection Voltage	4.7	V
$V_{HEAT}$	Overheat Voltage	2.0	

Note: Because the exact characteristics of the thermistor were unknown to us, the  $V_{HEAT}$  value given in the table above is only an example. Note that, generally, for this kind of batteries, the temperature limit is set to 45°C.

## 2.4 MCU SOFTWARE

### 2.4.1 Architecture

The software provided with the evaluation board has a state machine architecture. As explained further, 10 charging states can be defined for each slot. Each slot is driven by its state machine, with some interactions to implement front slot priority.

In order to measure the charge time, a timekeeper is implemented and counters are incremented periodically.

Most of the time, slot states are unchanged. This implies that the PWM duty cycle, charge enable signals and LED on/off states are constant. Periodically, the ST6 measures battery current, battery voltage and thermistor voltage for both slots. Using the measurements and the timekeeper values, it updates slot states and the output configuration. If necessary, it resets the timekeeper.

Figure 6. ST6255C Software Flowchart

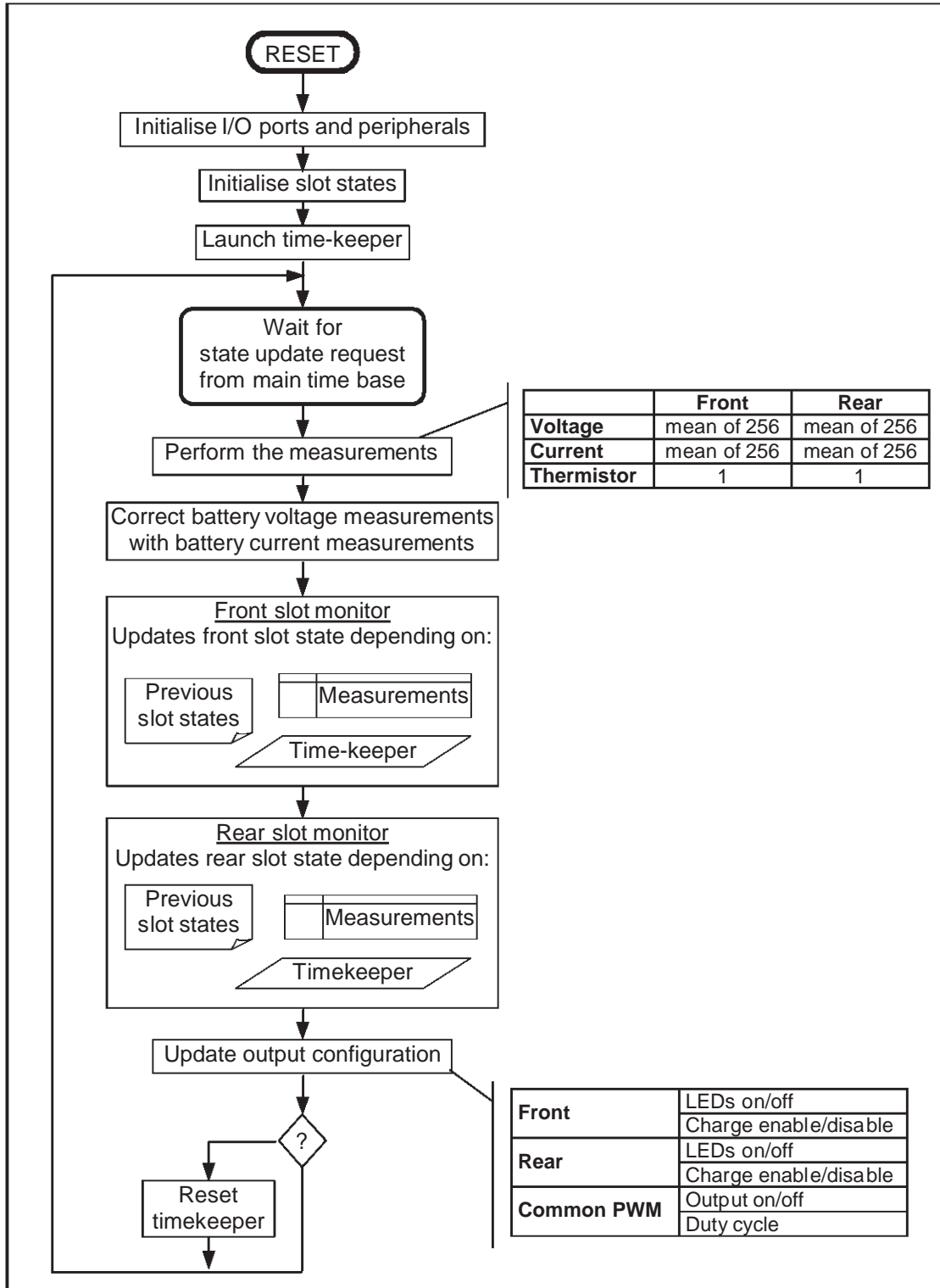

### 2.4.2 On-chip peripherals usage

The time base is given by the **standard timer** in output mode. When the timer counter reaches zero, the interrupt routine generates a state update request. In addition, it reloads the timer counter to start a new cycle.

In order to minimise supply current, the ST6 core puts itself into WAIT mode between two state updates.

In this example, this same interrupt routine (Timer Zero) also increments the timekeeper counters. This means the timekeeper is synchronised with the state updates.

The slot state update frequency is an important parameter. It must be high to maximise charging efficiency. On the other hand, if the output configuration has changed, it is useless to perform the next measurements before the system has stabilised. Therefore, an excessive update frequency could prove harmful. Thirdly, a low update frequency reduces overall power consumption.

The timekeeper divides the standard timer frequency. To do so, it contains three counters: `tick`, `chrono_lo` and `chrono_hi`.

**Table 4. Charge Timekeeper Counters**

		<b>tick</b>	<b>chrono_lo</b>	<b>chrono_hi</b>
Increment Condition		Timer Zero IT	<code>tick = 0</code>	<code>chrono_lo = 0</code>
<b>Period</b>	General	$T_{TMZ}$	$256 * T_{TMZ}$	$65536 * T_{TMZ}$
	Eval Board	6.1 ms	1.6 s	6 min 43 s
<b>Compared with</b>	General		$T_{fail}$	$T_{exp}$
	Eval Board		30 s	2.5 h

The PWM is generated by the **auto-reload timer** because a high frequency is required. In addition, this significantly reduces the CPU load, allowing the core to stay in WAIT mode most of the time. If no charge is under way on either slot, the PWM output is switched off in order to reduce consumption and increase A/D converter accuracy.

The **analog to digital converter** (ADC) is used intensively before each slot state update. In most cases, the PWM output cannot be disabled, so ADC accuracy is not optimal. To reduce errors, the ADC measures battery voltage and battery current 256 times in a row. The slot state monitoring software works with the mean values. The 256 measurements are added into a 16-bit word. The mean value is equal to the most significant byte of the word (rounded if the least significant byte is greater than 128).

As explained in Section 2.2, battery voltage measurements must be corrected with battery current measurements. These corrections require some arithmetical computing, performed on the 16-bit words.

**LOW-COST DOUBLE LI-ION BATTERY CHARGER USING ST6255C/ST6265C MCU**

The core puts itself into WAIT mode during each conversion in order to gain accuracy. Precision is improved even more by using the ADC SYNC option bit.

**2.4.3 State Diagrams**

A slot can be in one of the ten states described in the Slot States Definitions table, where *text in italic is valid only for the rear slot.*

**Table 5. Slot States Definitions**

Name	Meaning	Output configuration	Front priority request
		Slot Outputs	PWM Duty Cycle
IDLE	Slot empty <i>OR</i> <i>Charge suspended by front charge priority</i>	Charge disabled, Both LEDs off	Unchanged
CI	Constant current charge	Charge enabled, Green LED off, Red LED on	updated periodically to have $I_{bat} = I_{const}$
CV_D	Constant voltage charge, duty cycle down		Incremented periodically
CV_U	Constant voltage charge, duty cycle up		Decrementd periodically
FAST	Fast charge		Updated periodically to have $I_{BAT} = I_{FAST}$
TRI	Trickle charge		
SAT	Battery saturated	Charge disabled, Green LED on, Red LED off	Unchanged
EXP	Charge time expired		
FAIL	Battery failure	Charge disabled, Green LED off, Red LED flashing (toggled periodically)	
HEAT	Charge suspended by overheat	Charge disabled, Both LEDs on	
			Same as original state

Note that this choice of states is only one solution - among many - of implementing the required behaviour of the charger.

Here, “periodically” means “at every state update”. Therefore, the state update frequency is equal to the PWM duty cycle increase or decrease rate in the CI, CV\_D, CV\_U and FAST states. In FAIL state, the red LED flashing frequency is half of the state update frequency.

The diagram of state transitions is too complex to be described by only one figure. Hence the three figures in Figure 7. 't' stands for the timekeeper value. The rectangles represent actions performed once during a state transition.

The rear slot state is updated after the front slot state. As a result, a front priority request depends on the updated value of front state.

Once the slot is in a given state, conditions to move to another state are not always incompatible. Therefore, priority rules must be defined:

- 1 (Highest priority) Transition related to battery presence
- 2 Front slot priority
- 3 Temperature
- 4 Time
- 5 Battery current
- 6 Battery voltage

Figure 7. State Diagram (1) - Charging

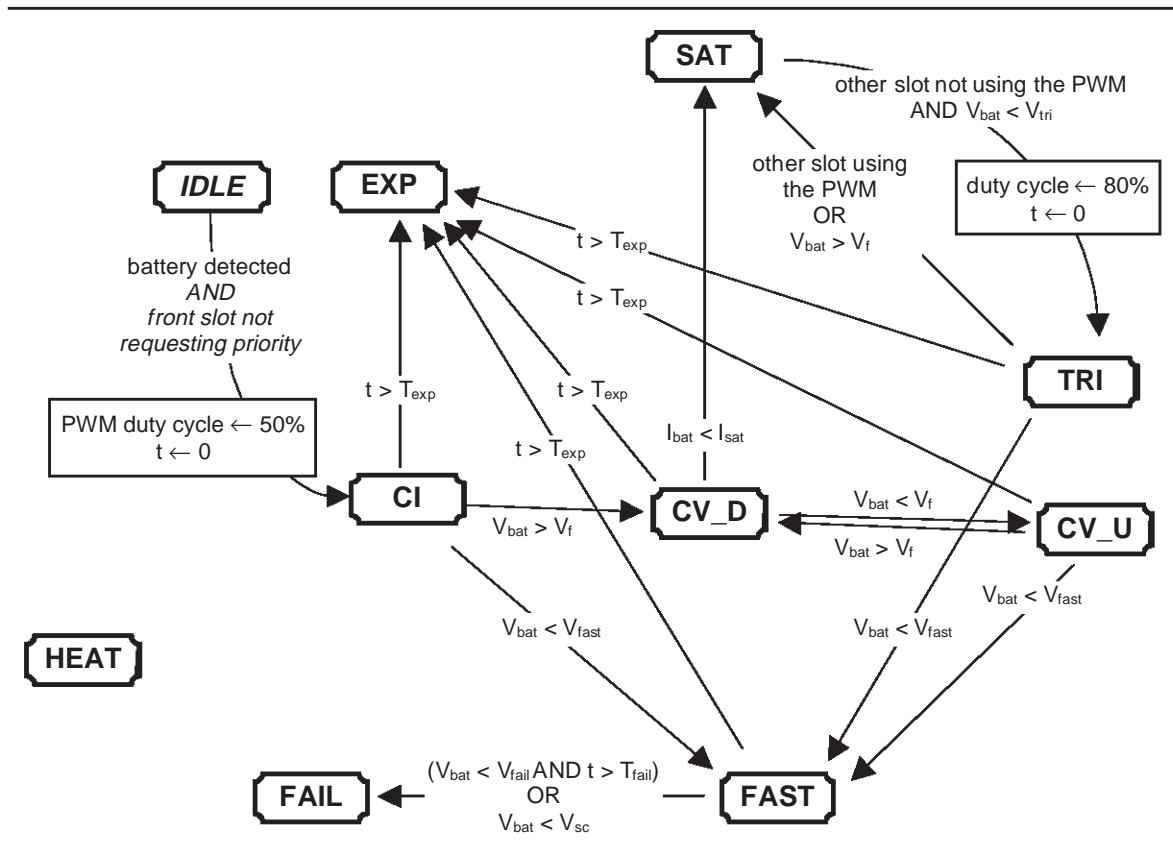

**Note:** A slot is considered to be using the PWM if it is in a charging state (CI, CV\_D, CV\_U, FAST or TRI) or if it is in HEAT state.

Figure 8. State Diagram (2) – Returning to IDLE State

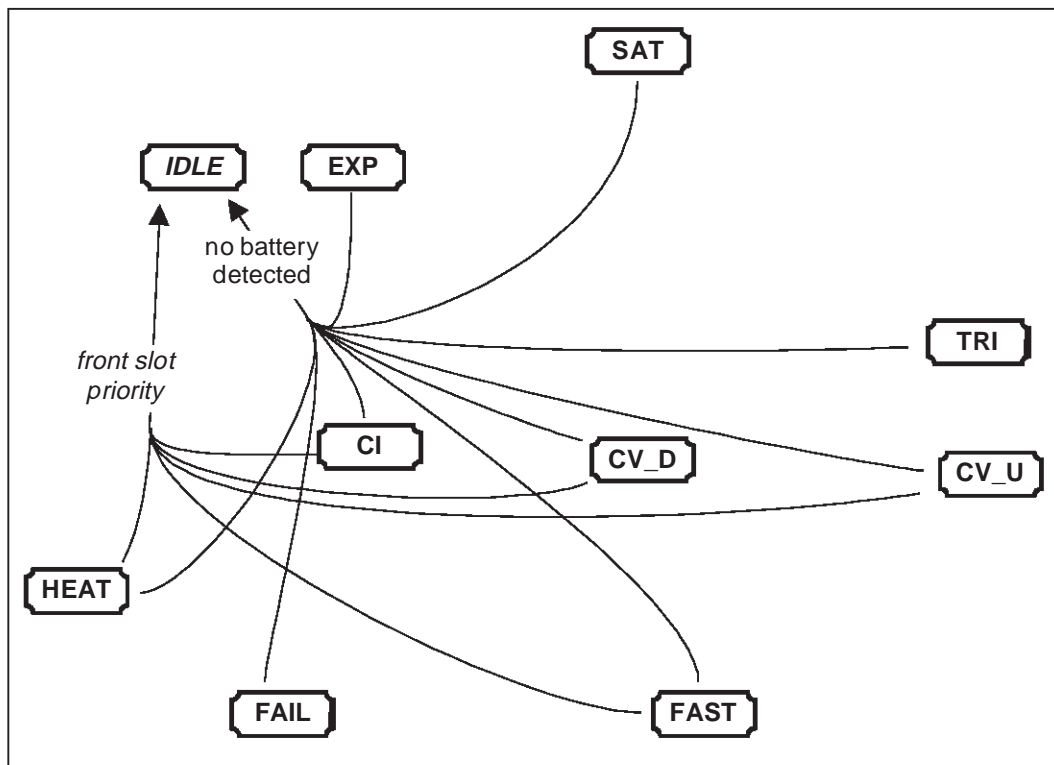
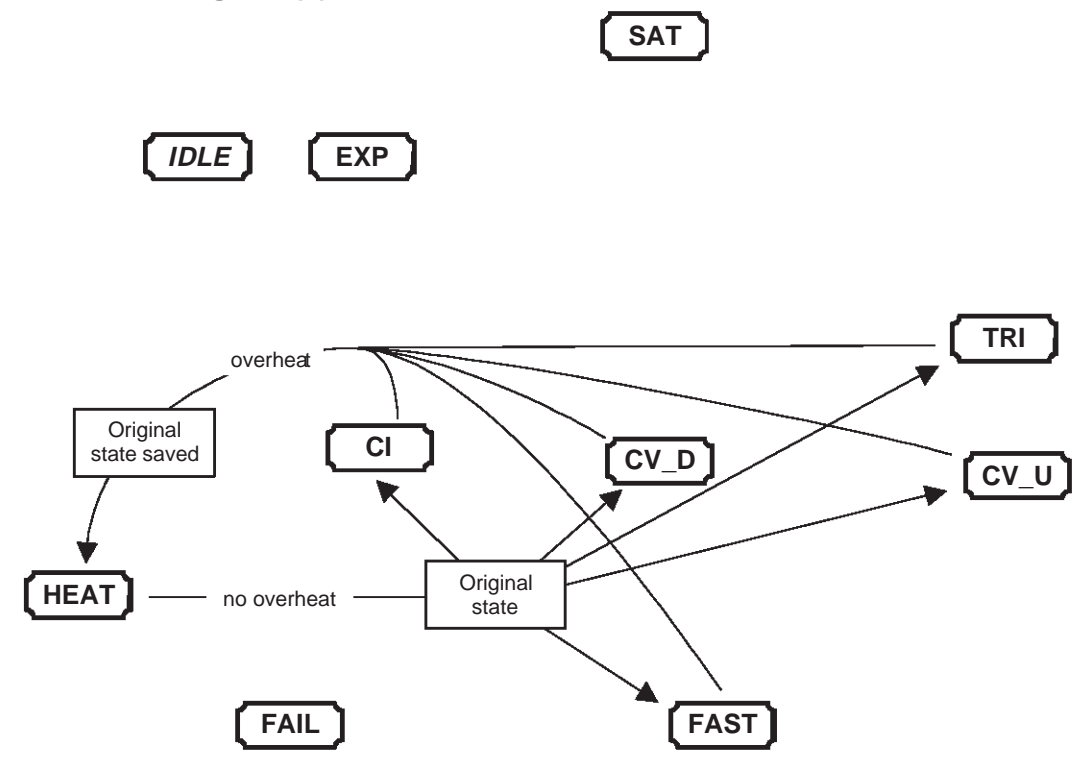

Figure 9. State Diagram (3) – Heat State Transitions



2.4.4 Slot Monitor Flowchart

In the software, slot states are updated by a subroutine called “slot monitor”. Using a subroutine is possible because the front and rear slot state diagrams are almost identical.

Slot state is stored in a one-byte variable, coded in a way that facilitates decoding the condition tree:

IDLE	EQU	00000001b
HEAT	EQU	10100000b
FAIL	EQU	11000001b
EXP	EQU	11010001b
SAT	EQU	11011001b
TRI	EQU	11100001b
FAST	EQU	11110000b
CV_D	EQU	11111000b
CI	EQU	11111100b
CV_U	EQU	11111110b

Decoding starts from the most significant bit. The least significant bit indicates front slot priority request (1 = no request). When the slot enters HEAT state, this bit is modified to be the same as in the original state. Bit  $b_5$  indicates if the slot is using the PWM ( $b_5 = 1$ ) or not ( $b_5 = 0$ ).

## **LOW-COST DOUBLE LI-ION BATTERY CHARGER USING ST6255C/ST6265C MCU**

---

The flowchart, represented in Slot Monitor Flowchart (1), Slot Monitor Flowchart (2) and Slot Monitor Flowchart (3), takes full advantage between transitions. For example, if the monitor knows that slot state is either CI, CV\_D or CV\_U, it can check the expiration time before switching to one of the three possibilities.

The order in which questions are asked (e.g. time before battery voltage) defines the priority of the state transition.

On the flowcharts, b<sub>7</sub>, b<sub>6</sub>, etc. refer to the corresponding bit in the slot state variable.

Figure 10. Slot Monitor Flowchart (1)

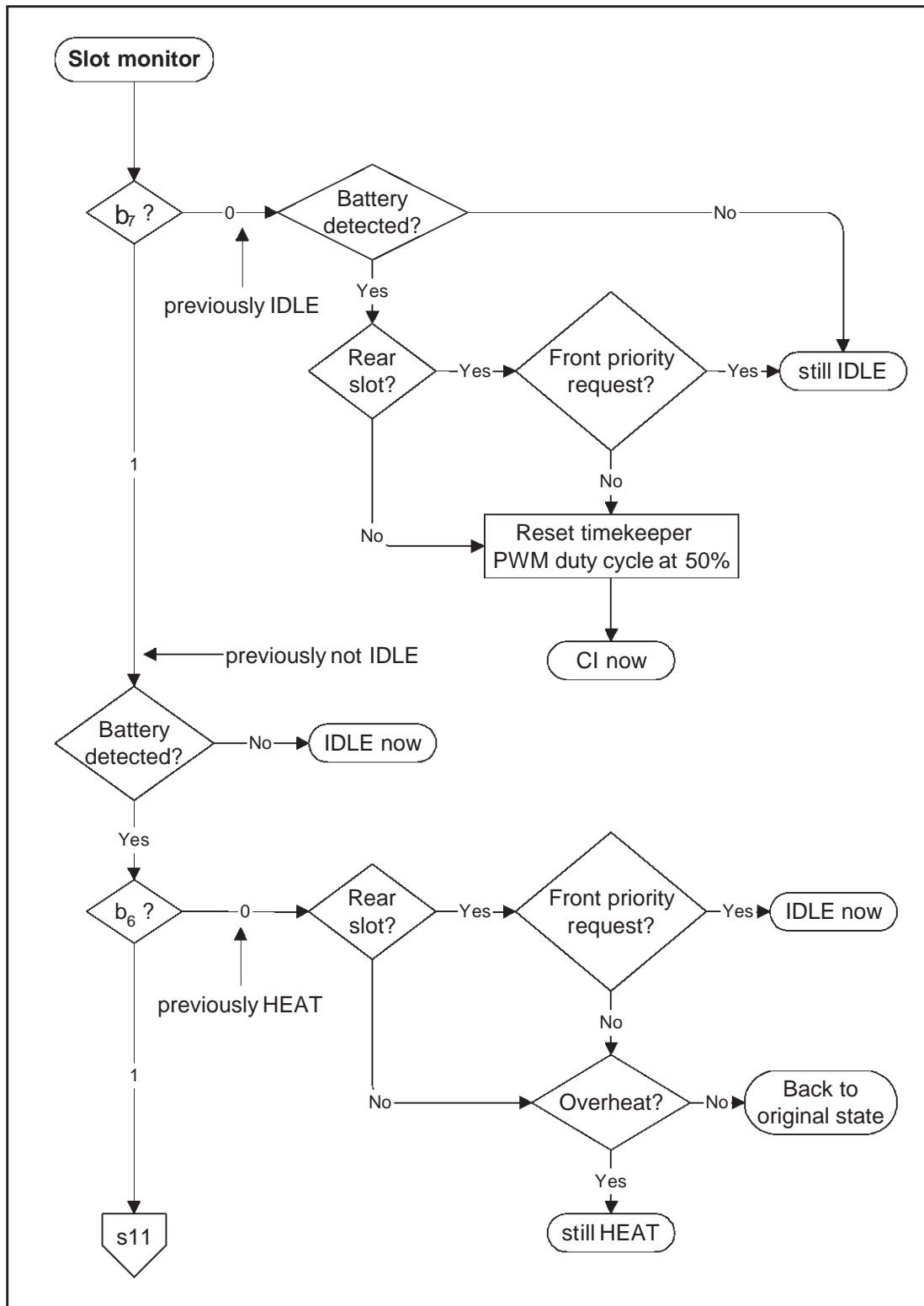

Figure 11. Slot Monitor Flowchart (2)

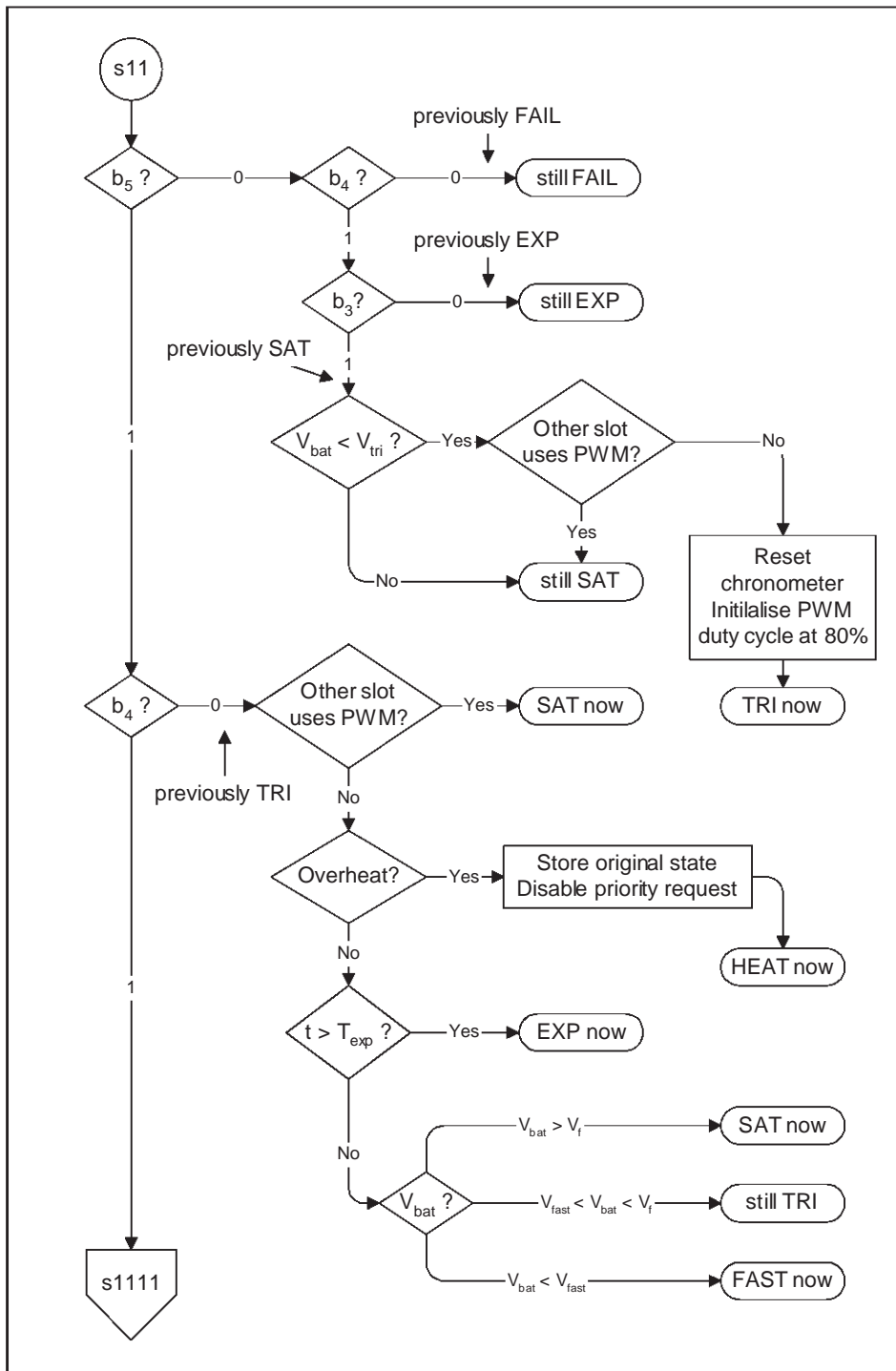

Figure 12. Slot Monitor Flowchart (3)

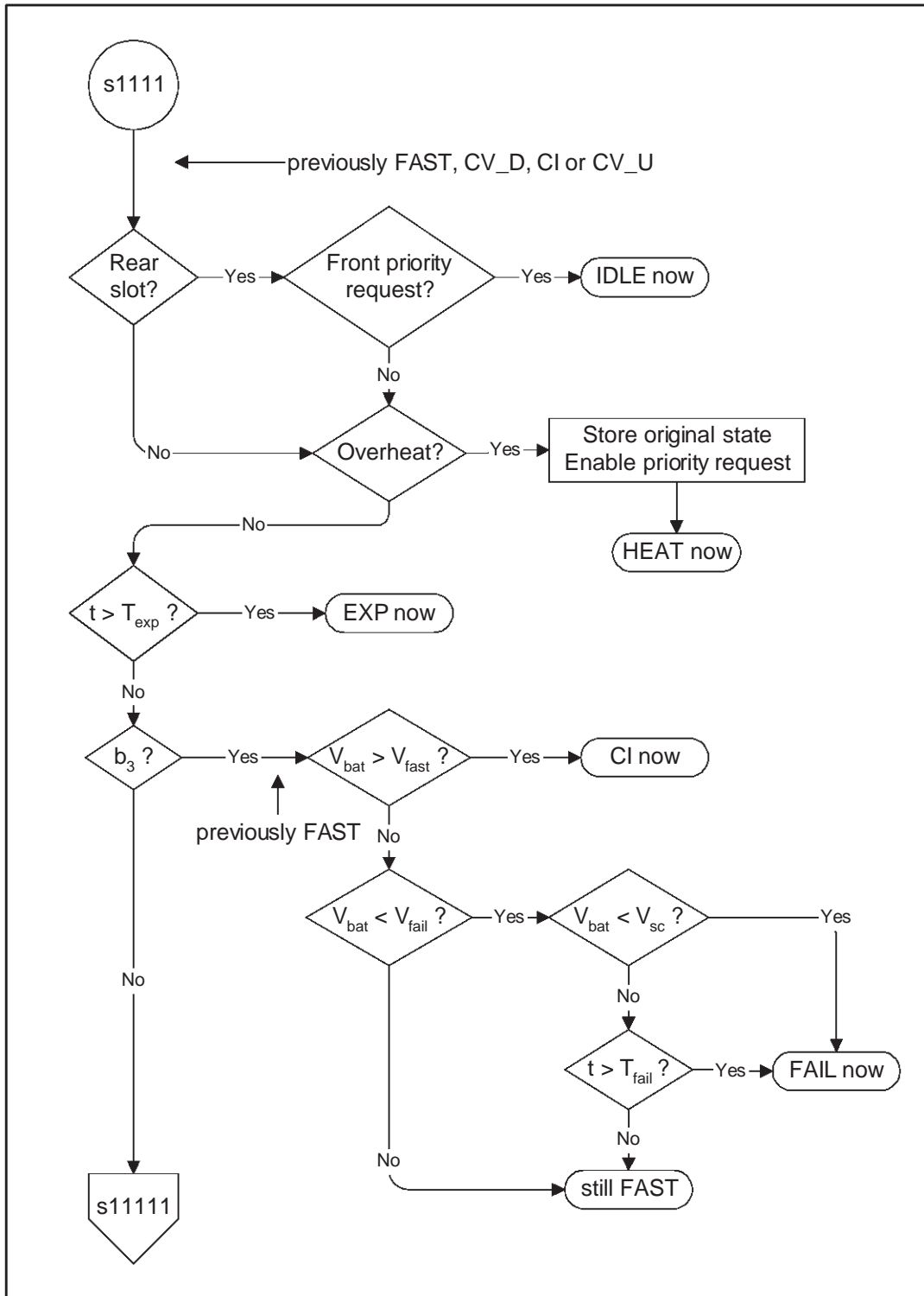
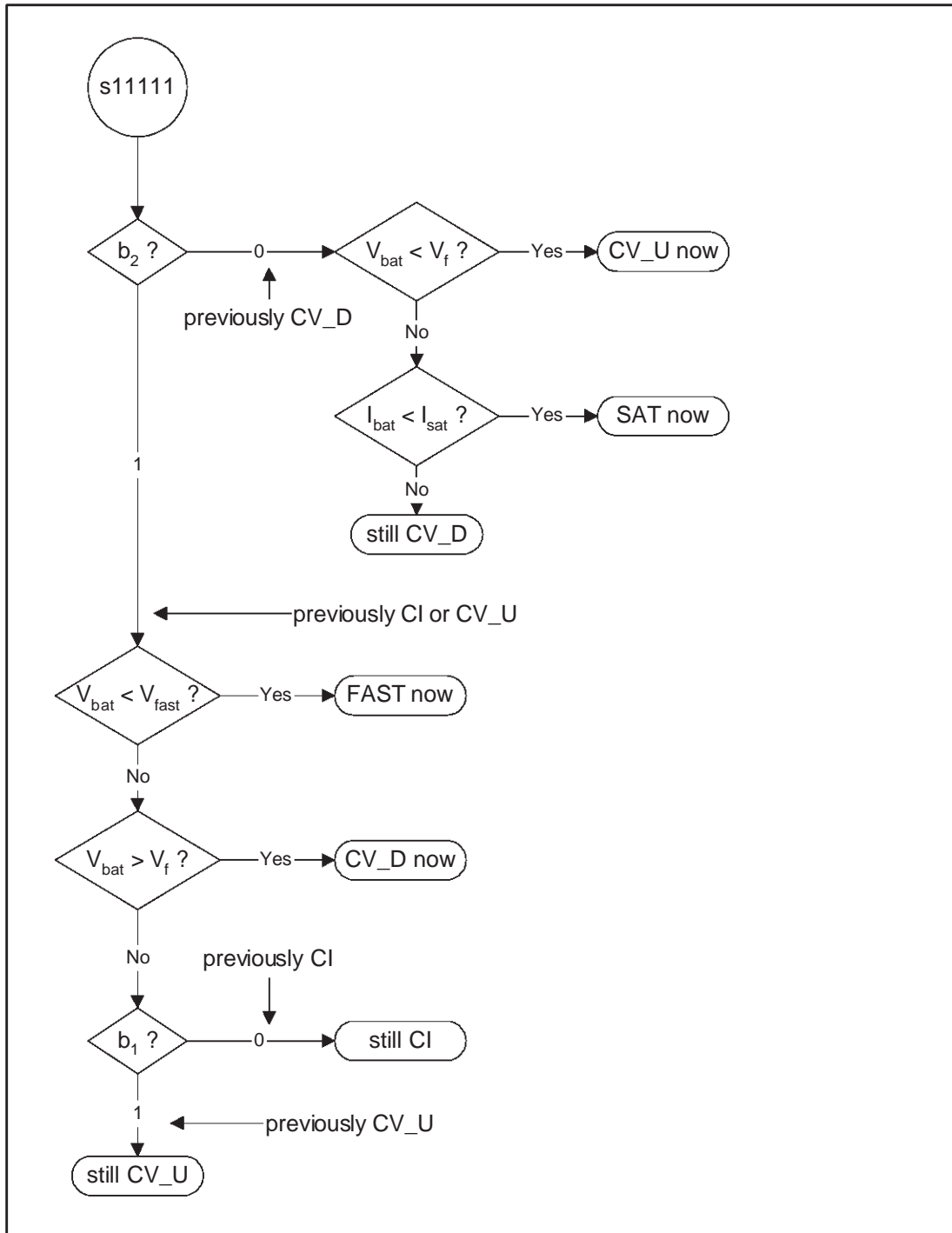

Figure 13. Slot Monitor Flowchart (4)



### 2.4.5 Source File Organisation

Code is written in RIDE MAST6 assembly language. It consists of five files:

- 1 program file `main.st6` (main routine, subroutines, interrupt service routines and interrupt vector definitions);
- 1 variable definition file `vars.st6`
- 3 header files:
  - `IOs.inc` (definitions of I/O configuration constants),
  - `vars.inc` (declarations of variables),
  - `params.inc` (definitions of application parameter constants).

This division makes it easier to perform minor modifications to the software, as shown in Table 6. Example of Minor Software Modifications.

**Table 6. Example of Minor Software Modifications**

If you want to change...	...only modify...
Voltage thresholds	params.inc
PWM frequency	
State update frequency	
Timing thresholds	
I/O configuration	IOs.inc
State diagram	state constant definitions and <code>monitor</code> subroutine in <code>main.st6</code>
State definitions	
Transition conditions	
Transition priority	

### 3 CONCLUSION: A LOW-COST FLEXIBLE SOLUTION

Everything on the evaluation board has been designed to make it easy to adapt in any way (other type of battery, new behaviour specifications, additional design constraints, etc.).

- The number of components needed for each slot (charging and feedback) is minimal, so replacing them is inexpensive. Besides, the circuit has a simple and predictable behaviour. This avoids costly and time-consuming trial-and-error procedures.
- The system has an inner self-adaptation capability thanks to its many closed loop regulations (voltage, current, temperature). For example, no software change is needed if  $V_{SUPPLY}$  changes – provided  $V_{DD}$  remains at 5 V.
- As explained in Section 2.4, parameter modifications in the software are easy to perform.
- The software only occupies a fourth of the total MCU program memory. Port C is not used at all; neither is the SPI (nor the EEPROM on the ST6265C). Subsequently, many improvements and/or new features can still be added without changing the MCU.
- Analog inputs available on Port C can read the identification resistor included in the batteries to determine their capacity and adapt the charging parameters accordingly.
- The EEPROM can be used for ADC calibration.

# LOW-COST DOUBLE LI-ION BATTERY CHARGER USING ST6255C/ST6265C MCU

## 4 APPENDIX

### 4.1 SCHEMATIC

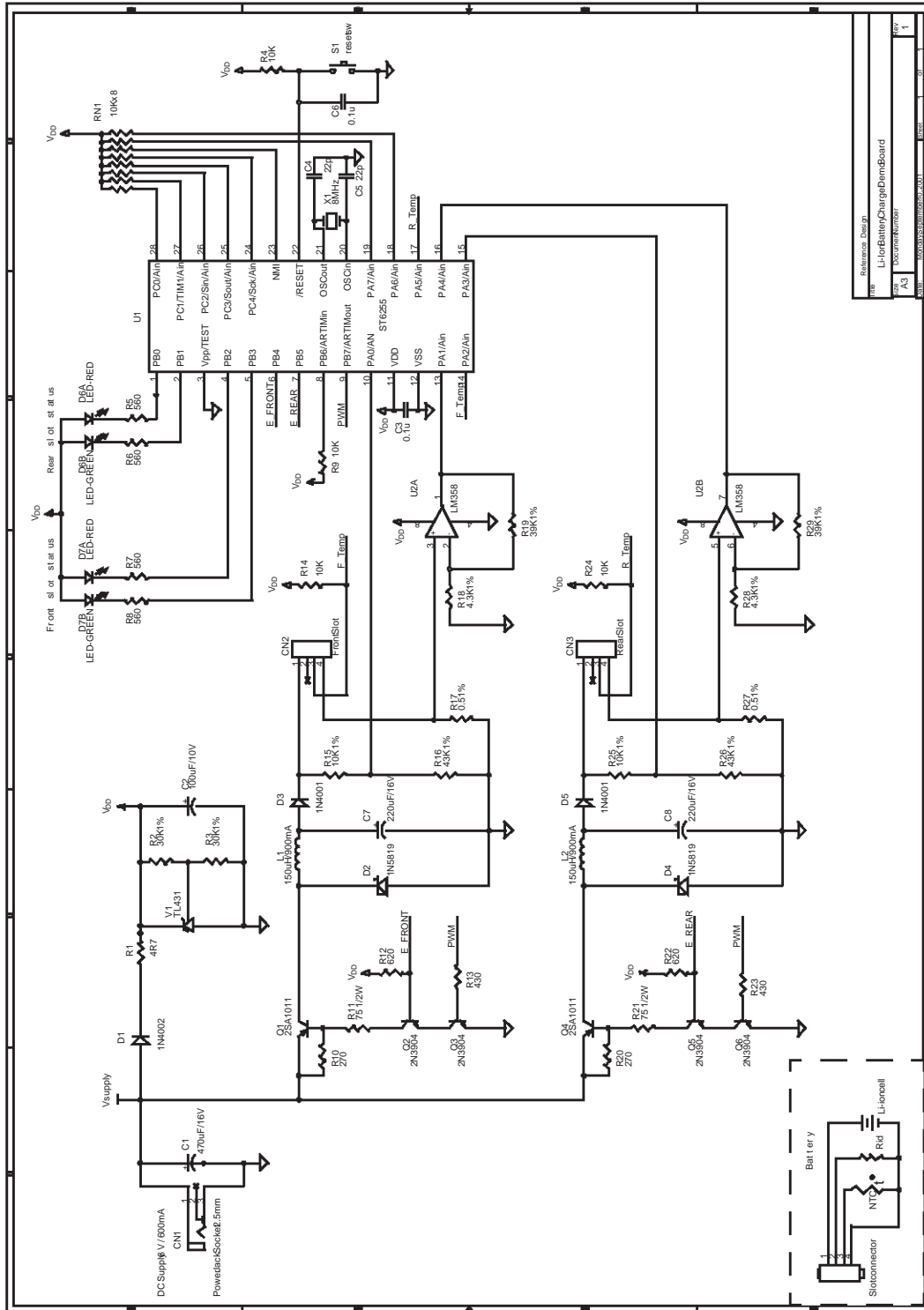

## LOW-COST DOUBLE LI-ION BATTERY CHARGER USING ST6255C/ST6265C MCU

### 4.2 BILL OF MATERIAL

Item	Quantity	Reference	Part
1	1	BT1	Li-ion cell
2	1	CN1	Power Jack Socket 2.5 mm
3	1	CN2	Front Slot
4	1	CN3	Rear Slot
5	1	C1	470uF/16V
6	1	C2	100uF/10V
7	2	C3,C6	0.1u
8	2	C5,C4	22p
9	2	C7,C8	220uF/16V
10	1	D1	1N4002
11	2	D2,D4	1N5819
12	2	D3,D5	1N4001
13	2	D6A,D7A	LED-RED
14	2	D6B,D7B	LED-GREEN
15	1	J4	Slot connector
16	2	L1,L2	150uH/900mA
17	2	Q1,Q4	2SA1011
18	4	Q2,Q3,Q5,Q6	2N3904
19	1	RN1	10K x 8
20	1	RT1	NTC
21	1	Rid	R
22	1	R1	4R7
23	2	R2,R3	30K 1%
24	4	R4,R9,R14,R24	10K
25	4	R5,R6,R7,R8	560
26	2	R10,R20	270
27	2	R11,R21	75 1/2W
28	2	R12,R22	620
29	2	R23,R13	430
30	2	R15,R25	10K 1%
31	2	R16,R26	43K 1%
32	2	R17,R27	0.5 1%
33	2	R18,R28	4.3K 1%
34	2	R19,R29	39K 1%
35	1	S1	reset sw
36	1	U1	ST6255
37	1	U2	LM358
38	1	V1	TL431
39	1	X1	8MHz

## LOW-COST DOUBLE LI-ION BATTERY CHARGER USING ST6255C/ST6265C MCU

---

“THE PRESENT NOTE WHICH IS FOR GUIDANCE ONLY AIMS AT PROVIDING CUSTOMERS WITH INFORMATION REGARDING THEIR PRODUCTS IN ORDER FOR THEM TO SAVE TIME. AS A RESULT, STMICROELECTRONICS SHALL NOT BE HELD LIABLE FOR ANY DIRECT, INDIRECT OR CONSEQUENTIAL DAMAGES WITH RESPECT TO ANY CLAIMS ARISING FROM THE CONTENT OF SUCH A NOTE AND/OR THE USE MADE BY CUSTOMERS OF THE INFORMATION CONTAINED HEREIN IN CONNEXION WITH THEIR PRODUCTS.”

Information furnished is believed to be accurate and reliable. However, STMicroelectronics assumes no responsibility for the consequences of use of such information nor for any infringement of patents or other rights of third parties which may result from its use. No license is granted by implication or otherwise under any patent or patent rights of STMicroelectronics. Specifications mentioned in this publication are subject to change without notice. This publication supersedes and replaces all information previously supplied. STMicroelectronics products are not authorized for use as critical components in life support devices or systems without the express written approval of STMicroelectronics.

The ST logo is a registered trademark of STMicroelectronics

©2001 STMicroelectronics - All Rights Reserved.

Purchase of I<sup>2</sup>C Components by STMicroelectronics conveys a license under the Philips I<sup>2</sup>C Patent. Rights to use these components in an I<sup>2</sup>C system is granted provided that the system conforms to the I<sup>2</sup>C Standard Specification as defined by Philips.

STMicroelectronics Group of Companies

Australia - Brazil - Canada - China - Finland - France - Germany - Hong Kong - India - Israel - Italy - Japan  
Malaysia - Malta - Morocco - Singapore - Spain - Sweden - Switzerland - United Kingdom - U.S.A.

<http://www.st.com>



LittleDiode supplies new, hard to find or obsolete electronic components and semiconductors all over the world.

With over two million different components listed you are sure to find the part you need.

Feel free to visit us today at our online store:

[LittleDiode.com](http://LittleDiode.com)

Looking forward to providing you with the best possible service.