

CL-PS7111 Evaluation Kit

User Manual

**Portable Systems
Cirrus Logic Inc.**

Scope and Applicability

The CL-PS7111 evaluation kit (Order no. CL-PSK7111DM01) is offered by Cirrus Logic to assist system designers in building CL-PS7111-based systems and developing and debugging drivers and application programs for this highly integrated microcontroller.

The evaluation kit provides software and hardware support to evaluate performance and measure power consumption under various conditions.

This kit contains a reference board to be used as the starting point for new designs. A system designer can elect to use the board as the 'motherboard' and simply add application-specific I/O modules to the board. For example, the designer of a two-way pager can incorporate the pager functionality as an I/O module attached to the basic board.

All engineering design collateral is provided in this kit.

System Requirements

The preloaded debug monitor requires a PC running the symbolic debug monitor PC (DOS or Windows® 95). Contact ARM at www.arm.com or Cirrus Logic to order the ARM toolkit containing a C-compiler, linker, and assembler. Familiarity with the ARM tools, such as ARMSD and/or Tool 200, is required to use the evaluation board.

Copyright © 1997 — Cirrus Logic Inc. All rights reserved.

This document describes a potential application of Cirrus Logic Inc. integrated circuits. No warranty is given for the suitability of the circuitry or program code described herein for any purpose other than demonstrating functional operation. The information contained in this document is subject to change without notice.

Table of Contents

List of Figures	3
List of Tables	3
1. INTRODUCTION	4
1.1 Ordering Information	4
2. EVALUATION KIT CONTENTS	5
2.1 Options	5
3. EVALUATION BOARD	6
3.1 Main Feature Set	7
3.2 Board Revisions	8
3.2.1 Software Revision	8
3.2.2 Endian Operation	8
3.2.3 Stuffing Options	8
3.3 Board Setup	9
3.3.1 Power	9
3.3.2 LCD	9
3.4 Boot Sequence	9
3.4.1 Boot Program Resize to 2 Kbytes	10
3.4.2 Boot Program File Format	11
3.4.3 Booting with Start Up Sequence from the Serial Port	11
3.4.4 Start Up Sequence Using Preinstalled Debug Monitor (DEMON)	12
3.4.5 Configure the ARM Debugger for Windows® (Tool v2.1)	13
3.5 Board Layout	14
3.6 Memory Architecture	18
3.6.1 Memory Map in Operating Mode	19
3.6.2 Memory Map in Boot Mode	19
3.7 I/O Port Allocation	20
3.8 Analog-to-Digital Converter	21
3.9 LCD Interface	21
3.10 J1 Connector Pinout	22
3.11 J24 Connector Pinout	23
3.12 Codec	23
4. DESIGN FILES	24
4.1 System Board	24
4.2 Key Board	24
5. BOOT CODE AND DEMON FILES	24
6. POWER SUPPLY DESIGN	25
6.1 Step-up Converter	25
6.2 Step-Down Converter	26
7. MEASURING CL-PS7111 POWER CONSUMPTION	27

8. DC-DC CONVERTER	28
8.1 Setup Procedure	28
8.1.1 Negative V_{EE}	31
8.1.2 V_{PP} Control	32
9. PC Card (PCMCIA) Interface	33
9.1 PC Card Power Switches at Multiple Points	33
9.1.1 PC Card Power	33
9.2 CL-PS7111-to-CL-PS6700 Interconnect Diagram	34
9.3 Interrupts	34
9.4 DMA Support	34
9.5 Power Down	34
9.6 Clocks	35
A. Source Address Locator	36
B. Bill of Materials	37
C. Schematics	46

List of Figures

<i>Figure</i>	<i>Page</i>
3-1 CL-PS7111 Evaluation Board Block Diagram	6
3-2 Null-Modem Cable	9
8-1 CL-PS7111 DC-DC Converter for Positive V_{EE}	29
8-2 CL-PS7111 DC-DC Converter for Negative V_{EE}	31
9-1 CL-PS7111-to-CL-PS6700 Interconnect Diagram	34

List of Tables

<i>Table</i>	<i>Page</i>
3-1 Assembly Instruction	8
3-2 Boot Software Programs	10
3-3 Port Allocation Pin Configuration	20
3-4 J2 Connector Pins	21
3-5 Compatible Panels	22
3-6 J1 Connector Pins	22
3-7 J24 Pin Connections	23
7-1 Typical Current Values at Various Conditions	27
8-1 V_{EE} Control Circuitry	28
8-2 Duty Ratio = 5	29
8-3 Duty Ratio = 2	30
8-4 Negative V_{EE} Control Circuitry	31
8-5 DC-DC Pump Ratio = 5	32
9-1 Switch Settings	33

1. INTRODUCTION

The CL-PS7111 evaluation kit is targeted for system designers who are developing CL-PS7111–based platforms. This kit is also for software developers who plan to port operating systems and applications to the CL-PS7111. To use the CL-PS7111 evaluation kit, the ARM toolkit containing the C-compiler, linker and assembler, debugger, and ARM instruction set emulators is required.

The CL-PS7111 evaluation kit is intended to be used with the ARM toolkit running on a PC with DOS, Windows 3.1 or Windows 95 installed.

1.1 Ordering Information

The following presents part numbering ordering information:

- CL-PS7111 Evaluation Kit: CL-PS7111-DMBD01
- ARM toolkit: PSKARMT00L-01

2. EVALUATION KIT CONTENTS

The evaluation kit contains:

- CL-PS7111 evaluation board
- Keyboard
 - X/Y key matrices
- LCD Panel
 - 240 × 100 pixels, 3.3-V Cirrus Logic, or
 - 320 × 240 pixels, 3.3-V Alps®
- Maxim® data sheets
 - Step-up/down converter
 - A/D converter
- Oki America®, Inc. data sheets
 - Telephone codec, MSM7702
 - Speaker amplifier, MSC1192
- ARM710 core data book
- 9-V AC/DC adapter
- CL-PS7111 demonstration program disk
- Schematic layout disk
- CL-PS7111 data book
- 2 null-modem cables
- ARM® debug monitor preloaded in flash memory

2.1 Options

One of the following panels can be made available upon request:

- Sharp® LM48014F
 - 480 × 320 pixels +28 V VEE
- Alps® KHABAA902A
 - 320 × 240 pixels +20 V V_{EE}

3. EVALUATION BOARD

The evaluation board is designed as a prototype with some debugging capabilities, such as test headers for logic analyzer trace, optional memory, and I/O configurations. Figure 3-1 shows the block diagram of the evaluation board.

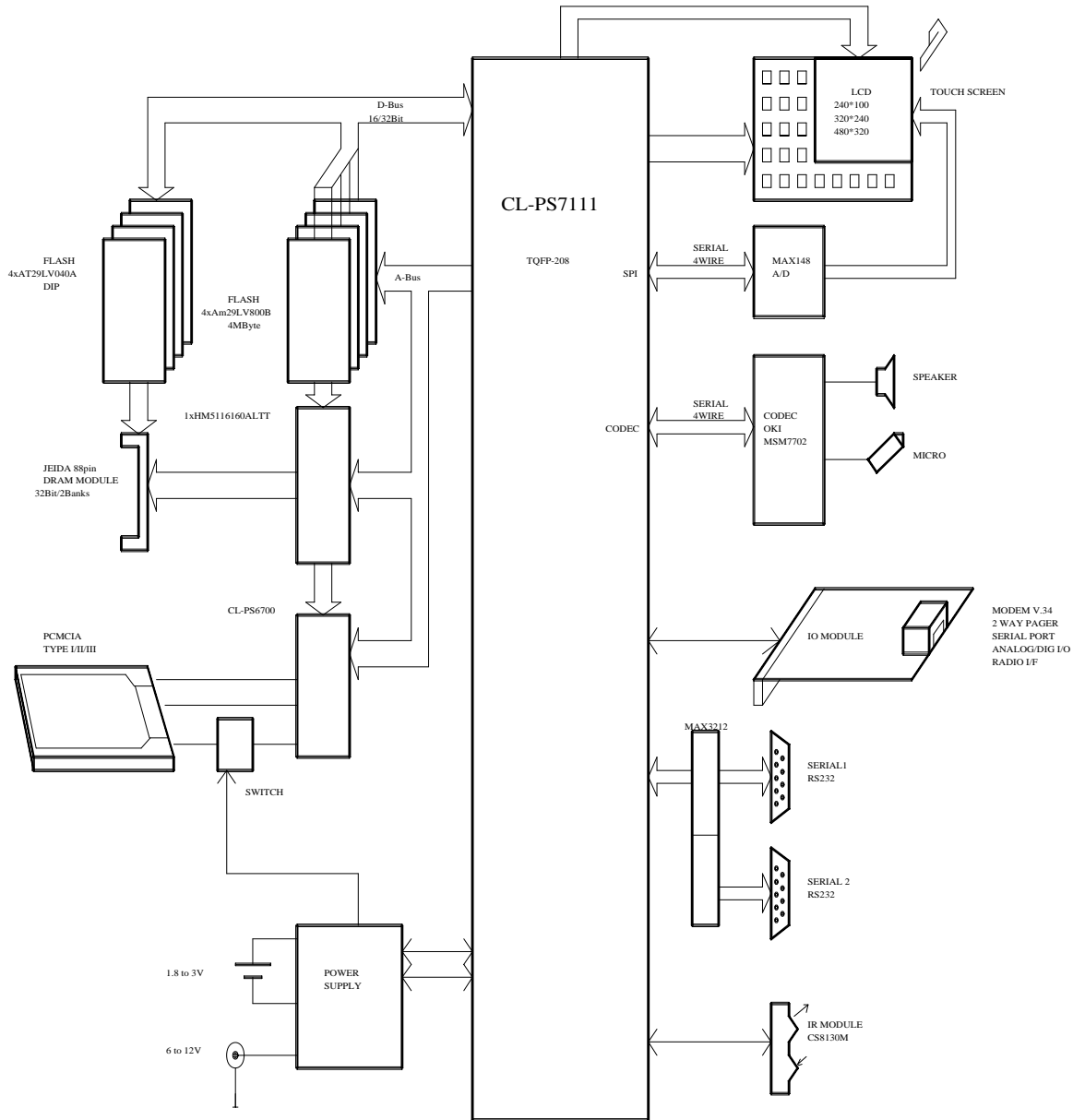

Figure 3-1. CL-PS7111 Evaluation Board Block Diagram

3.1 Main Feature Set

The evaluation board has the following features:

- Processing speed
 - 18.432 MHz
 - 13 MHz when using an optional oscillator
- Flash memory
 - 1 or 2 banks of 512K × 32 bits (2 Mbyte); reprogrammable at 3 V
- DRAM
 - 1 bank of 1 Mbit × 16 bit (2 Mbyte)
- JEIDA connector
 - DRAM expansion to two banks of 32-bit DRAMs are possible with this connector
- Power
 - Step-up converter from 1.8 to 4.0 to 3.3 V
 - Step-down converter from 6.0 to 14 to 3.3 V
 - PC card 3.3 or 5 V from V_{DD}
 - LCD bias V_{DD} to 35 V from 3.3 V (positive or negative bias selectable)
 - V_{PP} for PC card from V_{DD}
- Asynchronous serial port (two)
 - Ports programmable up to 115 kbaud
- Infrared
 - IrDA-compliant 115 kbaud (port multiplexed with asynchronous serial port 1)
- Keyboard
 - Keyboard matrix on daughter card (optional)
- PC Card
 - 68-pin card connector, fully isolated, 3.3 V or 5 V cards are supported
 - Supported by single-chip controller, CL-PS6700
- A/D
 - 10-bit A/D converter, 8 channels, MAX 148
- Codec
 - Telephone codec, OKI MSM7702
- Speaker
 - With amplifier, OKI MSC1192
- LCD
 - Three optional LCD connectors
- Expansion Connector
 - 50-pin expansion connector for add-on peripherals 8-bits wide, such as UART- and SPI-compatible peripherals
- Boot from serial port with 32-bit wide flash

The debug monitor that is preprogrammed into the flash memory requires that a PC be connected through a serial cable on serial port 2, and that the PC run the ARM symbolic debugger. Other operating systems are downloadable as described in Section 3.4 on page 9.

3.2 Board Revisions

The board described in Rev 0.2 of the Evaluation Kit User's Manual is Revision A. The CL-PS7111 is on a socket and can be replaced with the current revision. A separate errata sheet is also available. Please contact Cirrus Logic for the latest silicon status.

3.2.1 Software Revision

There has been a change in the ARM compiler in Toolkit v2.0 and later. Please note that assembly instruction ADR is no longer supported when addresses are defined using equates. Use the LDR instruction as shown in Table 3-1.

Table 3-1. Assembly Instruction

Old		New	
ADR	R4, LCD address	LDR	R4, = LCD address

3.2.2 Endian Operation

The CL-PS7111 is a bi-endian processor however, all supplied programs operate in Little Endian mode. No hardware change is required for Big Endian mode. The byte-lane switch is performed inside the memory controller.

3.2.3 Stuffing Options

A number of stuffing options are available:

- Clock source
 - 18 MHz from 3.6864 MHz crystal
 - 13 MHz from oscillator
- V_{EE} control
 - Positive or negative
- LCD panel
 - 3.3-V panel 240 × 100
 - Other panels can be connected on jumpers J2 and J15
- Buzzer
 - Use loud speaker instead of buzzer
- DRAM
 - Use 32-bit wide banks as supported on the JEIDA connector

Though the board could also be stuffed with one bank of 16-bit flash memory in Bank 0, the reprogramming of AMD flash must be unlocked by a proper address/data sequence cannot be performed. Use 32- or 8-bit wide banks of AMD flash memory. If 16-bit wide flash must be used, then use devices that require a programming voltage, V_{PP} .

3.3 Board Setup

This serial port connection is through the supplied null-modem cable to the port marked *SERIAL 2* and to the PC host port COM1 or COM2.

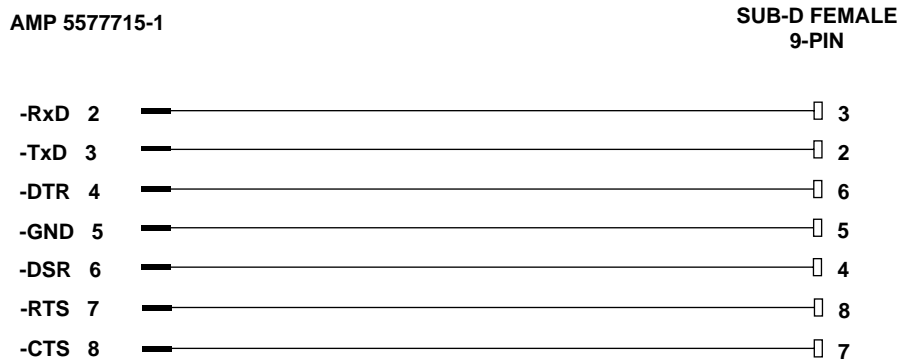

Figure 3-2. Null-Modem Cable

3.3.1 Power

Two AA batteries connected to J3 or a 9-V AC/DC adapter connected to J9 can provide power through a 1.3 mm circular connector. GND is on the center pin. When using a battery connected to J3, ensure the polarity is correct.

3.3.2 LCD

Connect the provided LCD module to the 17-pin flat cable on J1. Other panels can be connected to the 11-pin connector, J3, and the 17-pin connector, J15. The pinout of these connectors are compatible with some Sharp and Alps panels, respectively. Ensure that the polarity for V_{EE} is properly set for panels that require V_{EE} for contrast control. Solder bridges W1, W2, W7, and W8 *must* be properly set, and some resistors must be properly stuffed (refer to legend included in the schematics in Section 3.5 on page 14).

3.4 Boot Sequence

The on-chip boot program can be activated by pulling MEDCHG/–BOOTEN low at power up. This allows code to be easily loaded into the flash memory. Use UART Port 1 of the CL-PS7111 to boot up. The standard setting is 9600 baud, 1 start bit, 1 stop bit, and no parity. The evaluation kit includes a modified version of the ARM debug monitor (ROMU2L) preloaded into the flash memory.

The debug monitor operates from UART2. An optional add-on board can be connected to the 50-pin connector, J10. If it is necessary to operate the debug monitor from the serial port on this module to free UART2, then the program ROMDBL must be loaded into the flash memory.

The on-chip boot code executes at power up when the boot is enabled. The MEDCHG/–BOOTEN pin must be low at the rising edge of –POR. An on-chip boot program code is executed as discussed in the *CL-PS7111 Data Book*. This code loads a 2-Kbyte file into the on-chip SRAM of the CL-PS7111, jumps to

the beginning of the 2k block, and executes the loaded program that in turn loads a debug monitor (such as DEMONU2L) or an operating system.

The loaded code is referred to as the *secondary boot code*. This code actually boots the operating system and programs the flash. The file size of BOOTAMD0 is exactly 2048 bytes, and it always uses UART1. This program can be customized if another interface is selected (such as the IrDA port or a PCMCIA flash card). The code is stored into the on-board flash memory beginning at memory address space 0. Once the code is successfully loaded, the system *must* be powered down and the boot switch (jumper) removed (the MEDCHG/–BOOTEN signal must be high). On the next power up, the program executes from memory address space 0 out of Flash Bank 0.

Two separate programs are provided for Bank 0 and Bank 1. The operating system normally provides the ‘flashing’, other than the mandatory boot block. If the DEMON is running, use the supplied program, FLASH, to erase and program individual sectors.

Table 3-2. Boot Software Programs

Program	Function
BOOTAMD0	Initial program that downloads to SRAM, must be exactly 2 Kbytes; downloads code into Bank 0.
BOOTAMD1	Initial program that downloads to SRAM, must be exactly 2 Kbytes; downloads code into Bank 1.
ROMU2L	DEMON uses UART2; little endian.
ROMDBL	DEMON uses add-on module; little endian.
FLASH	Program executes under DEMON; erases and programs flash memory.

3.4.1 Boot Program Resize to 2 Kbytes

The initial boot program that is loaded into the on-chip SRAM must be exactly 2 Kbytes. If the BOOTAMD0 program is compiled and linked, the size must be adjusted to meet this parameter. To do this, simply load the program with DEBUG into memory, adjust CRX to 800, and write back the file. The following example code shows this sequence:

```
DEBUG BOOTAMD0
-RCX < 800
-W
```

NOTE: The memory map of all memory selected by CS0 through CS5 (and internal CS6 and CS7 areas) is reversed: Bank 0 (CS0) is located at 0x7000 0000 during boot.

3.4.2 Boot Program File Format

Once BOOTAMD0 has been loaded into SRAM and given control by the boot loader. The program prompts for the file name containing the binary. The format for this file is:

- 4 bytes - first address (Little Endian)
- 4 bytes - length of data in bytes (Little Endian)

The following example code is a script for adding header and length information to the top of the file using DOS debug commands:

```
e f8
00 00 00 00 00 c0 00 00
rcx
c008
nrom1.bin
wcs:f8
q
```

3.4.3 Booting with Start Up Sequence from the Serial Port

In this mode, the on-chip boot program loads the boot code into the on-chip SRAM from serial port 1, then loads a program (such as the debug monitor) into flash. The following is a procedure to load the boot program.

1. **Install the ARM software development toolkit.**
2. **(DOS only) Run RECONFIG from the ARMPC386 directory.**
 - a) Select the ARMSD setup and the little endian serial port at 9600 baud.
 - b) Exit and save this configuration.
3. **Set the BOOTEN jumper, W15.**
4. **Connect the PC from which to download the boot code to the serial port 1.**
5. **Select 9600 baud.**
6. **Run a terminal program, such as Winterm.**
7. **Power down.**
8. **Power up.**
9. **Press the WAKEUP button, S1.**

At this point the '<' character will have been received from serial port 1.

10. **Send the file BOOTAMD0 after receiving '<'.**

After 2 Kbytes are sent, '>' appears on screen. The downloaded program begins executing at address 0000 0000 from the on-chip SRAM.

The program also prompts that it is ready to receive data. Send the code to download (such as ROMU2L) or any other program (for example, the operating system). The binary file must contain a header, the length, the binary file, and the destination start address to be loaded. See Section 3.4.2 on page 11.

11. Switch W15 to N (normal boot).
12. Power down.
13. Power up.
14. Press the WAKEUP button, S1.

At this point a banner message appears followed by the ARMSD: prompt.

3.4.4 Start Up Sequence Using Preinstalled Debug Monitor (DEMON)

Use the following procedure to load the start up sequence using the preinstalled debug monitor, DEMON.

1. Install the ARM software development toolkit.
2. (DOS only) Run RECONFIG from the ARM\PC386 directory.
 - a) Select ARMSD setup and the little endian serial port at 9600 baud.
A higher baud rate can be used, but ARMSD is not reliable above 9600 baud on certain host systems.
 - b) Exit and save the configuration.
3. Connect the serial port labeled SERIAL 2 with the supplied null-modem cable to one of the PCs serial ports.
4. Connect the power supply.
5. Launch ARMSD on the PC.
 - a) If connected to Port 1 (COM1) type: ARMSD
 - b) If connected to Port 2 (COM2) type: ARMSD -p 2
6. Press the RESET button, S2.
7. Press the WAKEUP button, S1

If system does not wake up, press the RESET button followed by WAKEUP. Wait a few moments for the debug monitor to complete memory test and initialization. Then the initial message reporting the DRAM size (0x20 0000) and the debug monitor version appears.

Ensure that the memory size is correct. If the sign-on message does not appear, but instead there is an <ARMSD> prompt, the parameters in RECONFIG to the serial port are not properly set.

3.4.5 Configure the ARM Debugger for Windows® (Tool v2.1)

The ARM debugger for Windows (ADW) must be configured for remote target. Use the following procedure.

1. **Choose** `Configure Debugger` **from the** `Option` **menu.**

The `Configure Debugger` `Option` menu opens.

2. **Click the** `Target` **button to move to the** `Remote Debug Interface` **window.**
3. **Click** `Add`.
4. **Select** `remote_d` **from the** `Target Environment` **window.**
5. **Click** `Configure`.
6. **Select the desired baud rate in the** `Configure` **window.**

3.5 Board Layout

The following two schematic diagrams present board layout recommendations.

Please contact Cirrus Logic for the latest schematic diagrams.

The following lists the reference designators used in the schematics:

Designator	Part
W	Permanent selectors, normally the solder bridges
J	Jumper or connectors
S	Switches
TP	Test points

The following lists the reference designators for jumpers and solder bridges:

Designator	Function
W1	V _{EE} voltage selection
W2	V _{EE} voltage selection
W3	aLAW/uLAW selection
W4	PC Card data bus power selector
W6	Bank 0 select 16/32 bit
W7	V _{EE} voltage selection
W8	V _{EE} voltage selection
W11	Boot ROM enable for 32-pin DIP option
W12	Interrupt selection for PC Card
W13	–CAS0
W14	–CAS1
W15	Boot select

The following lists the reference designators for connectors:

Designator	Function
J1	17-pin LCD connector
J2	11-pin LCD connector
J3	Battery connector
J4	Keyboard connector
J5	Optional speaker
J6	Ear phone connector
J7	Microphone connector
J8	IR module
J9	1.3 mm external supply connector
J10	Expansion connector
J11	68-pin PC Card connector
J12	Serial Port 1, RS-232 levels
J13	Expansion ROM connector (not populated)
J14	Serial Port 2, TTL
J15	LCD ZIF connector for Alps panels
J16	Touch panel
J17	88-pin JEIDA, DRAM module

Designator (<i>cont.</i>)	Function
J19	L/A control signals
J20	L/A Data[15:0]
J21	L/A Address[15:0]
J22	L/A Address[27:16]
J23	L/A Data[31:16]
J24	LCD signals header
J25	Serial Port 2, RS-232 levels

The following lists the reference designators for the switches:

Designator	Function
S1	Manual wake-up
S2	User reset

3.6 Memory Architecture

The memory consists of two banks of flash and one bank of 16-bit wide DRAM (each 2 Mbytes). Additional DRAM can be added on a JEIDA memory module.

The boot flash can be 16-bits wide; however, 16-bit flash memory cannot be written to because of the way the AMD flash is reprogrammed by applying a sequence of memory addresses and data. An optimal configuration uses 8-bit wide memory. If 16-bit wide memory is required, use memory with V_{PP} -enabled programming.

The standby current of the complete system is determined by the DRAM current in self-refresh mode. This is why a low refresh current is important.

Additional RAM can be placed on the add-on debug module using a serial EEPROM.

3.6.1 Memory Map in Operating Mode

Physical Address Space	Description
0000 0000	Starting address of debug monitor
0000 0000–001F FFFF	2-Mbyte flash; 3 V Bank 0
1000 0000–101F FFFF	2-Mbyte flash; 3 V Bank 1
0000 3000	Location of the character set
0000 4000	Page tables
3000 0000–300F FFFF	External serial port (expansion space)
4000 0000–43FF FFFF	PC Card attribute space; 8-bits wide
4400 0000–47FF FFFF	PC Card memory space; 8/16 bits (byte/word addressable)
4800 0000–4BFF FFFF	PC Card I/O space; 8/16 bits
6000 0000–6000 07FF	On-chip SRAM; 2 Kbytes
7000 0000–6000 007F	On-chip boot code; 128 bytes
8000 0000–8000 1800	CL-PS7111 registers ^a
C000 0000–C001F FFFF	2-Mbyte DRAM
C000 0000–C001 FFFF	LCD buffer – default address ^b
C002 0000–C002 7FFF	Work area for debug monitor
C002 8008	Applications program start address
C002 8000–C01F FFFF	DRAM used by software ^b

^a Refer to the *CL-PS7111 Data Book* for complete register descriptions.

^b The DRAM is a 16-Mbit DRAM organized as 12 row addresses and 8 column addresses. In this non-square configuration, the memory controller splits the memory into eight 256-Kbyte segments with equal size gaps between the segments. To get a contiguous memory segment, use the MMU to map pages of physical memory into the virtual address space of the CPU. The page tables starting at location 0x4000 describe page addresses, protection status, and cacheability of individual pages.

3.6.2 Memory Map in Boot Mode

The memory map is different if the system is booted when the MEDCHG signal is low. All memory spaces are selected through CS0..CS5; the on-chip memory space in address space CS7 and the SRAM at CS6 are reversed. Therefore, the boot code appears at location 0x0000 0000, while the on-chip SRAM appears at 0x1000 0000. The DRAM and on-chip registers are not remapped.

3.7 I/O Port Allocation

Table 3-3 shows allocation, pin configuration, and function for the I/O port.

Table 3-3. Port Allocation Pin Configuration

Port	Reset State	Drive	Direction	Signal	Description
PA[7:0]	Input	Standard	I	ROW[7:0]	Keyboard row input pulled down by R81 resistor network.
PB0	Input	Standard	I/O	PB0	PRDY of PC Card controller CL-PS6700.
PB1	Input	Standard	I/O	PB1	TSMY drive.
PB2	Input	Standard	O	PB2	Volume control: 0 = high volume 1 = low volume
PB3	Input	Standard	O	PB3	PC Card V _{PP} : 0 = enable 12 V 1 = enable 5 V
PB4	Input	Standard	O	PB4	PC Card power shutdown converter: 0 = turn off PC Card power 1 = turn on PC Card power
PB5	Input	Standard	O	PB5	Power telephone codec MSM7702: 0 = turn off codec 1 = turn on codec
PB6	Input	Standard	O	PB6	Power speaker amplifier: 0 = turn off amplifier; digital input on 1 = turn on amplifier; digital input off
PB7	Input	Standard	O	PB7	Power A/D converter: 0 = turn off A/D converter 1 = turn on A/D converter
PD0	Output-low	Standard	O	RTS	Request to send output — active-high.
PD1	Output-low	Standard	O	DTR	PC Card voltage select: 0 = enable 5 V 1 = enable 3.3 V
PD2 ^a	Output-low	Standard	O	PD2	Serial port off — active-low: 0 = disable RS-232 driver 1 = enable RS-232 driver
PD3	Output-low	Standard	I/O	PD3	Expansion connector.
PD[7:4]]	Output-low	Standard	O	PD4..7	LCD contrast control.
PE0	Input	Standard	O	PE0	LCD Display Signal: 0 = disable; LCD off 1 = enable; LCD on

Table 3-3. Port Allocation Pin Configuration (cont.)

Port	Reset Sate	Drive	Direction	Signal	Description
PE1	Input	Standard	O	PE1	IR transmit enable: 0 = enable 1 = disable
PE2	Input	Standard	O	PE2	TSPX drive panel.

^a Since the on-chip boot program expects data on serial Port 1, the RS-232 driver must be enabled. U20 is enabled by port PD2, which is an output after power up. The optimal solution is to use PB2 with a pull-up resistor so that the RS-232 driver is enabled, and use PD2 as volume control port.

3.8 Analog-to-Digital Converter

A 10-bit A/D converter, MAX148, is used in the board design. This is actually a 12-bit converter and must be set up for 128-kHz ADCCLK, a frame length of 24, and unipolar input. Connect a potentiometer or a waveform generator on R47 with a maximum amplitude of 1.5 V. For further information, refer to the MAX148 data sheet.

3.9 LCD Interface

There is no industry standard for an LCD panel pinout. Operating voltages, as well as interface connectors, vary from supplier to supplier. One of the more common pinouts is J2 with pin assignments, as shown in Table 3-4.

Table 3-4. J2 Connector Pins

Pin#	Symbol	Signal Name
1	FRM	Frame Signal
2	CL1	Line Clock
3	CL2	Shift Clock
4	PE0	LCD (on signal if high)
5	V _{DD}	3.3 V
6	GND	Frame Signal
7	V _{EE}	Selectable from approximately +30 V to -30 V
8	D0	Data 0
9	D1	Data 1
10	D2	Data 2
11	D3	Data 3

The panels shown in Table 3-5 can be connected and are available from Cirrus Logic upon request. These two panels are 5 V and are for evaluation only. Contact your supplier for availability of 3.3-V panels.

Table 3-5. Compatible Panels

Supplier	Type	Size	V _{DD}	V _{EE}
Sharp	LM48014F	480 × 320	5 V	+28 V
Sharp (minor cable adjustment required)	LM320081	320 × 240	5 V	-18 V

V_{EE} can be selected and the voltage can be adjusted under software control, as described in Section 3.8.

3.10 J1 Connector Pinout

A second interface connector, J1, is provided for a custom panel from Cirrus Logic. This panel is 240 × 100 pixels and operates on a single 3.3-V supply. This panel uses the M signal (AC modulation).

Connect the Cirrus Logic LCD panel (240 × 100) on J1 as shown in Table 3-6.

Table 3-6. J1 Connector Pins

Pin Number	Symbol	Signal Name
1	V _{DD}	3.3V
2	D0	Data 0
3	D1	Data 1
4	D2	Data 2
5	D3	Data 3
6	GND	Ground
7	FRM	Frame
8	GND	Ground
9	CL1	Line Clock
10	GND	Ground
11	CL2	Shift Clock
12	GND	Ground
13	M	Modulation
14	PE0	LCD On
15	n/c ^a	–
16	n/c	–
17	n/c	–

^a 'n/c' indicates a pin that is a no connect.

3.11 J24 Connector Pinout

The J24 connector is compatible with following Alps panels:

- KHABAA902A, 320 × 240
- KHABAA901A, 320 × 240
- KHABFC901A, 160 × 240
- KHABFA901A, 240 × 160
- KHABBB904A, 480 × 320

Table 3-7. J24 Pin Connections

Pin Number	Symbol	Signal Name
1	V5	Bias Supply Voltage
2	V2	Bias Supply Voltage
3	V _{EE}	LCD Driver Supply Voltage
4	V _{DD}	Logic Supply 3.3 V
5	FRM	Frame Signal
6	GND	Ground
7	CL1	Line Clock
8	GND	Ground
9	M	AC Signal
10	PE0	Display on Signal (1 = on)
11	CL2	Shift Clock
12	V4	Bias Supply Voltage
13	V3	Bias Supply Voltage
14	D3	Data 3
15	D2	Data 2
16	D1	Data 1
17	D0	Data 0

3.12 Codec

The schematics and bill of materials in this document shows the part number of the codec, MSM7702. The codec interface is directly compatible without interface logic. The power amplifier, MSC1192MS, must be turned off at the end of every transmission to silence the speaker and conserve power. The gain of the microphone can be adjusted by the R6, ~100-k Ω resistor. A buzzer is optional. Since the buzzer output goes into the digital input of the power amplifier, it is not required if a speaker is present. To enable the digital input, the -STDY input of the MSC1192MS must be high.

4. DESIGN FILES

4.1 System Board

The schematics can be found in one of two OrCAD formats. The design database file is provided as an ASC file that can, if necessary, be converted into other formats. The following are the absolute paths of the zipped schematic files provided in this kit.

Path and Filename	File Type and Contents
\schematic\EVAL7111.SCH	Orcad 386+ format use library REF7110D.LIB
\schematic\EVAL7111.DSN	Orcad Capture for Windows Format
\schematic\EVAL7111.LIB	Orcad Library file
\schematic\EVAL7111.BOM	Bill of Materials
\layout\EVAL7111.ASC	PADS PERFORM v.6 ASC file
\layout\BATCHL.DAT	PADS Batch file to generate gerber files

4.2 Key Board

The following are the absolute paths of the schematic files available through the Cirrus Logic BBS.

Path and Filename	File Type and Contents
\schematic\KEYB.SCH	Orcad 386+ format use library REFDEBUG.LIB
\schematic\KEYB.DSN	Orcad Capture for Windows Format
\schematic\KEYB.LIB	Orcad Library file
\layout\KEYB.ASC	PADS PERFORM v.6 ASC file

5. BOOT CODE AND DEMON FILES

For a complete listing of files, see the README file on the BOOT floppy disk.

6. POWER SUPPLY DESIGN

The power supply design consists of a number of individual units that provide power from two AA batteries, as well as an AC/DC adapter that ranges from 6 to 12 V. Backup during sleep mode can be provided from a gold capacitor, C33, that keeps the 32-kHz oscillator active, or from a lithium battery with some minor rework required.

NOTE: All power rails *must* be supplied with power. It is not recommended to simply provide power to the realtime clock oscillator while core and I/O are turned off.

The power supply is divided into following units:

- Step-up converter
- Step-down converter
- Backup supply: gold capacitor or lithium battery
- PC Card supply
- V_{EE} for LCD
- V_{PP} for PC Card

There is also a bias generator for the Alps LCD panels. This bias generator divides V_{EE} appropriately to supply V2..V5 for the panel.

The CL-PS7111 is in any of three modes:

1) Boot mode

Internal boot ROM at location 0x0000 0000 loads 2 Kbytes of data from UART1 at 9600 baud. The memory is remapped.

2) Operating modes:

- a) Run mode: CPU on, LCD on
- b) Idle mode: CPU off, LCD refresh on
- c) Standby mode: CPU off, LCD refresh off, and DRAM in the self-refresh state

3) Test modes

NOTE: There are several test modes that are described in detail in the *CL-PS7111 Data Book*.

6.1 Step-up Converter

Connector J3, Pin Header

Pin 1	VBATT	Battery voltage between 2–3 V (target) Use FET U26 with low UGS (such as Si6426)
Pin 2	GND	

The main power should be provided from two alkaline AA batteries. The supply is in the range of 2–3 V, depending on the remaining charge. The step-up converter, U24 (MAX608), can be turned off during power down *only* when the CL-PS7111 is in the Idle mode.

In Idle mode, the power required for the entire system is largely determined by the power-down current of the DRAMs, which can be put into the self-refresh state. Typically, the leakage current of the entire system is between 50–300 μ A. An inverted RUN signal powers up the MAX608.

Note that the reference voltage is also off in Standby mode. This is because the debug UART add-on module and the associated RS-232 driver (MAX212) are still running during that time.

Since the RUN signal starts just prior to the execution of the first instruction (in 18-MHz operation), it is important that no accesses to memory or I/O devices occur until full power is restored. To do this, execute out-of-cache and set up a secondary ‘wakeup’ source after which the CPU can make memory references.

In 13-MHz operation with the PLL bypassed, the wakeup time is reduced from 10 ms instead of the 250 ms required for 18-MHz operation. This allows toggling at a fast rate in and out of the Standby state.

6.2 Step-Down Converter

Connector J9, 1.3 mm Circular Connector

Pins 1 and 3	Sleeve	VEXT	Power from AC/DC converter (6 to 12 V)
Pin 2	Center	GND	

The step-down converter, LM1651, operates from anywhere from V_{DD} to 16 V and is also referred to as the External power source. If VEXT power is on, the input, -EXTPWR, is active to the CL-PS7111. This protects the CPU from exiting the Standby state if the NPWRFL signal is active.

The following sections provide a detailed description of the four pins on the CL-PS7111 that are dedicated to battery power management.

MEDCHG/BOOTEN

This input detects to a switch that signals that a PC Card (or other I/O card) is being removed. This input is deglitched so that a mechanical switch can be used. When this input is low at power up, the CL-PS7111 boots up from the on-chip ROM and loads 2 Kbytes of data from UART 1 at 9600 baud.

BATOK

This signal is derived from a comparator that is set to switch when the main battery dies. A transition to low generates a FIQ interrupt. The O/S must ensure that the system powers down into Standby mode so as to not entirely drain the battery. Logic integrated in the CL-PS7111 prevents the system from starting up unless the power fail condition (NPWRFL not active) is removed.

NEXTPWR

This input must be driven when an external power supply, other than the main battery, is powering the system. Only when this input is high *and* NPWRFL is not active will the system exit Standby mode. This prevents the system from attempting to wake up when the main battery is dead or fatally drained.

BATCHG

This input, when asserted, will not generate an interrupt. It signals that there is no battery present. It can be generated by an external comparator that senses battery voltage.

NPWRFL

This input immediately places the system in Standby mode. It will first sense that the DRAM access is complete and placed in self-refresh mode and reset the CPU.

7. MEASURING CL-PS7111 POWER CONSUMPTION

The current supply of the CL-PS7111 is separated into I/O (pad), core, 32-kHz oscillator, and 3.6864-MHz PLL oscillator nodes. The current drawn by the CL-PS7111 can be observed by a mA-meter connected to L1, L4, and L5. These are usually bridged by solder bumps. No filters are required in the supply. Use the POWER program to cycle through the different power states.

The mA-meter can be connected to solder pads L4 and L5 to measure the oscillator and core currents, respectively. To measure the 32-kHz oscillator current, a mA-meter is required in place of D6. C33 must be removed so as not to measure the leakage current. Ensure that the meter switch is uninterrupted when changing range. The current can change by three orders of magnitude.

The current drawn depends on how individual modules are activated. Some typical values are shown in Table 7-1. The values may change depending on the programming conditions.

Table 7-1. Typical Current Values at Various Conditions

Node Name	Name	Run	Idle	Standby
I/O	V _{DDE}	<15 mA	<1 mA	<5 μ A
Core	V _{CORE}	<3 mA	<2 mA	<1 μ A
32-kHz oscillator	V _{32K}	<10 μ A	<10 μ A	<10 μ A
3.6864-MHz PLL oscillator	V _{OSC}	<1.2 mA	<1.2 mA	<1 μ A
Total approximate:		<30 mA	<15 mA	<17 μ A

8. DC-DC CONVERTER

The CL-PS7111 device provides dedicated support for DC-DC conversion through two duty-cycle-programmable 96-kHz clocks. One set of clocks can be used for keeping a constituent V_{EE} supply voltage for the LCD panel; the second set can be used to generate the programming voltage V_{PP} . These clocks can also be used for the voltage of the backlight.

The schematic in Figure 8-1 is for positive and negative V_{EE} control circuitry. V_{EE} must be closely controlled over a relatively wide range to adjust for voltage and temperature variations. The reference board is designed to select positive or negative V_{EE} through the proper setting of solder joints W1, W2, W7, and W8.

The four output ports, PD[7:4] can change V_{EE} with software control. The pump ratio duty cycle is selected so that sufficient current is provided and the inductor is not going into saturation. In the example in Table 8-1, a pump ratio of four was sufficient.

Table 8-1. V_{EE} Control Circuitry

Resistor	Function
R75	Pull-down resistor for positive V_{EE} .
R53	Pull-up resistor for LM339 open-drain output.
R54	Selects a voltage at the + terminal of the comparator where the feedback output switches off (high) and turns off the Drive output.
R55	Selects the voltage level on + input of comparator to apply to V_{REF} (1.5 V); for 28 volts, $R55 = 22 \text{ k}\Omega$. Adjust this resistor to increase/decrease the voltage range; a lower value increases the voltage range.
R62 to R65	This resistor network enables V_{EE} to be programmed under software control. All outputs low indicate that V_{EE} is at maximum. Turning on the outputs increases the voltage at the comparator, decreasing V_{EE} .

8.1 Setup Procedure

Assuming that the nominal V_{EE} voltage for a given LCD is 28 V and the range is from 27–29 V do the following to ensure sufficient contrast control range:

1. **Connect a load resistor at C2 to force application of a 2–5 mA current (or whatever the typical value for the panel is).**
2. **Program the Pump Control register to 5.**
3. **Set PD[7:4] to high.**
4. **Set R55 so that minimum V_{EE} is 27 V.**
5. **Set PD[7:4] to '1111'; V_{EE} should exceed 29 V.**

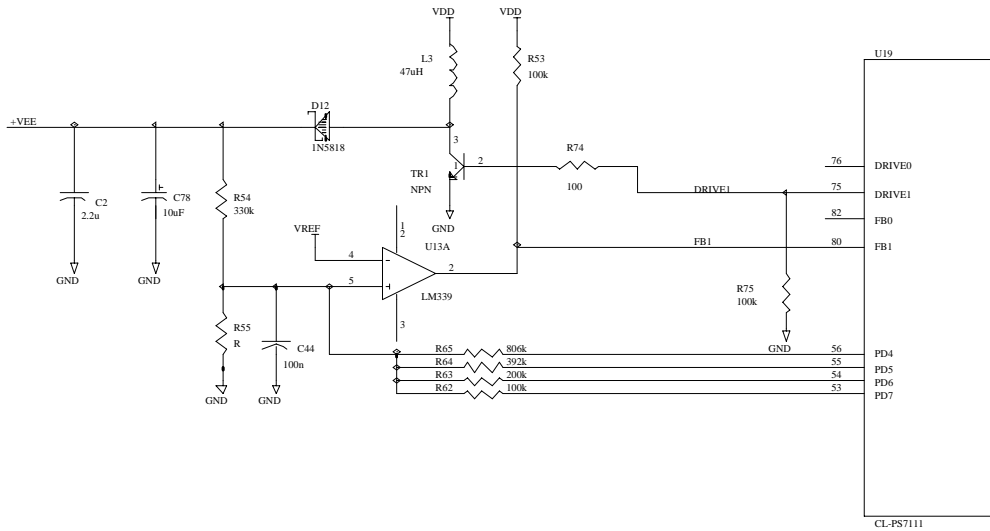

Figure 8-1. CL-PS7111 DC-DC Converter for Positive V_{EE}

Measured V_{EE} values for a duty ratio of 5 are shown in Table 8-2.

Table 8-2. Duty Ratio = 5

Port PD[7:4]	Pump Ratio 5	
	[V]	[V]
0	30.8	31.12
1	29.04	29.34
2	27.2	27.48
3	25.4	25.70
4	23.6	24.0
5	21.9	22.18
6	20.0	20.32
7	18.3	18.56

Table 8-2. Duty Ratio = 5 (cont.)

Port PD[7:4]	Pump Ratio 5	
	[V]	[V]
8	16.2	16.45
9	14.5	14.68
A	12.7	12.85
B	10.98	11.1
C	9.27	9.33
D	7.53	7.57
E	5.7	5.79
F	4.06	4.06

Measured V_{EE} values for a duty ratio of 2 are shown in Table 8-3.

Table 8-3. Duty Ratio = 2

Port PD[7:4] = 2	Pump Ratio V_{EE} [V]
0	3.74
1	18.92
2	26.18
3	26.83
4	27.06
5	27.19
6	27.28
7	27.34
8	27.39
9	27.44
A	27.48
B	27.51
C	27.53
D	27.54
E	27.58
F	27.59

8.1.1 Negative V_{EE}

Table 8-4 shows the resistors required for the control circuitry on negative V_{EE} . Figure 8-2 is a sample schematic for a DC-DC converter on negative V_{EE} .

Table 8-4. Negative V_{EE} Control Circuitry

Resistor	Function
R73	Pull-up resistor for negative V_{EE} .
R53	Pull-up resistor for the LM339 open-drain output.
R54	Selects a voltage at the terminal of the comparator where the feedback output switches off (high) and turns off the Drive output.
R56	Selects the voltage level on the input of comparator to apply to VREF (1.5 V).
R62..65	This resistor network allows V_{EE} to be programmed under software control. All outputs low indicate that V_{EE} is at maximum. Turning on the outputs increases the voltage and therefore decreases V_{EE} .

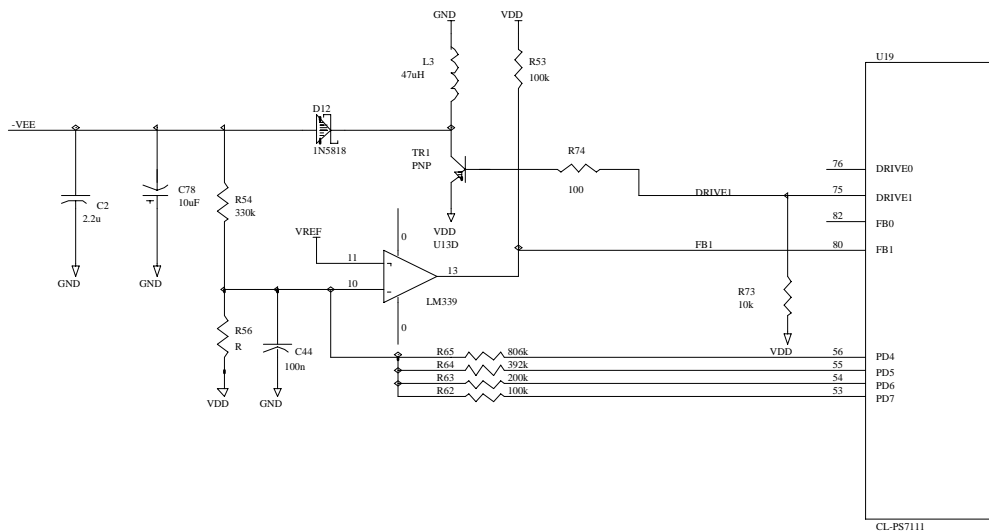

Figure 8-2. CL-PS7111 DC-DC Converter for Negative V_{EE}

8.1.2 V_{PP} Control

V_{PP} is controlled by DRIVE0. The circuitry is designed to turn on with 5 or 12 V. If PD6 is high, the transistor, TR4, turns on. This determines V_{PP} for 12 V by switching R57 in parallel to R59. If TR4 is turned off, V_{PP} is set to 5 V. Turning the pump ratio to 0 turns off the U21 switch, and V_{PP} is effectively turned off. The DC-to-DC pump ratio (PR), if set to 5, yields adequate power.

Table 8-5. DC-DC Pump Ratio = 5

V_{DD}	PR	PB3 = 0	PB3 = 1	Load Resistor
3.6 V	4	5.6 V	12.78 V	1.2 k Ω
3.6 V	5	5.78 V	12.98 V	1.2 k Ω
3.6 V	A	6.8 V	14.22 V	1.2 k Ω

9. PC Card (PCMCIA) Interface

The PC Card interface consists of the single-chip controller, CL-PS6700, that provides a fully v2.1-compliant PC Card interface, including software-controlled DMA and mixed-voltage operation on a small-footprint package. During Sleep mode, this controller is not drawing any measurable current, while still signaling a card change condition. Two interrupts could be used going to the CL-PS7111, but for all examples in this application, only PIRQ_L is connected to –EINT1.

9.1 PC Card Power Switches at Multiple Points

First, turn the power on for converter U1 and set for 5-V operation (see PB4 and PD1). Next, V_{PP} must be set to 5 V, as controlled by the on-chip DC-DC converter. Finally, to turn on the appropriate switch or switches, the MOSFET switch, U28, must be controlled by writing the Power Management register of the CL-PS6700.

Table 9-1. Switch Settings

V_{PP}	V_{PC}	S4	S3	S2	S1
5 V	5 V	0	1	V_{PC}	0
5 V	3 V	1	0	V_{PC}	0
12 V	5 V	0	1	V_{PC}	1
12 V	3 V	1	0	V_{PC}	1

The CL-PS6700 operates on split power planes to isolate the PC Card slot from the system. There are a number of internal pull-up resistors and logic that must operate if power to the CL-PS6700 is off. This also requires that the applied VDD_HI signal is higher than the card voltage or V_{DD} , respectively. A Schottky diode, D16, in the power path assures that the VDD_HI signal selects the higher of either the card voltage (3.3 or 5 V) or V_{DD} .

9.1.1 PC Card Power

In most applications, a 200-mA power source is sufficient to drive a PC Card. To optimize the requirement, the following exchangeable converters can be used:

- MAX858 — up to 50 mA at 5 V
- MAX856 — up to 100 mA at 5 V
- MAX756 — up to 200 mA at 5 V

9.2 CL-PS7111-to-CL-PS6700 Interconnect Diagram

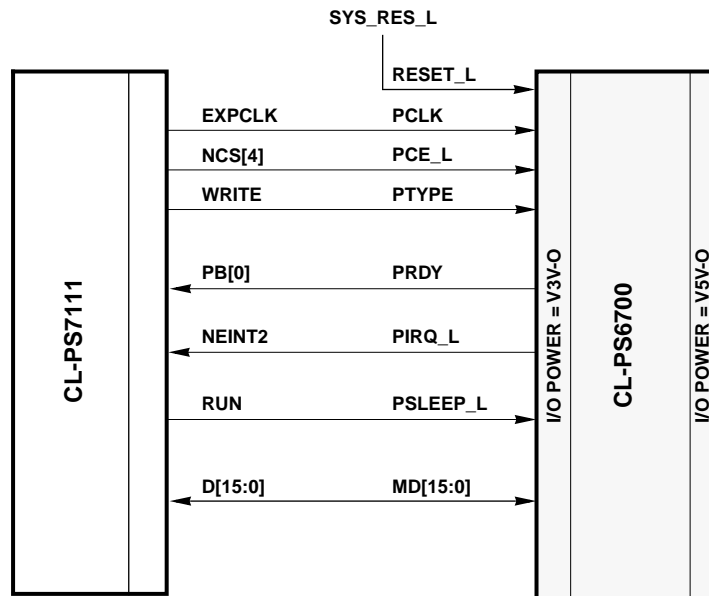

Figure 9-1. CL-PS7111-to-CL-PS6700 Interconnect Diagram

9.3 Interrupts

The two interrupt outputs of the CL-PS6700 are open-drain and must to be pulled up. An interrupt in the CL-PS6700 can be promoted to FIQ status (that is, the status change may cause a fast interrupt or one separated out for fast interrupt response). Connect W12 to wire the FIQ output on the board to the external -EXFIQ interrupt. Since -EXFIQ can also be used by the expansion board, ensure it is being driven by an open-drain output to make the wire OR connection.

9.4 DMA Support

The PDREQ_L output of the CL-PS6700 is pulled high on the board (open-drain output). If DMA is required, connect this output to an interrupt on the CL-PS7111. Then DMA can be supported by software emulation (use -EXFIQ). PDREQ_L can also be used as a GPIO.

9.5 Power Down

Whenever the CL-PS7111 enters Standby mode, the CL-PS6700 enters Power-Down mode. This is because the RUN signal is connected to the PSLEEP_L input. Ensure that there are no pending transactions before the CL-PS7111 enters Standby mode and that the transaction queue in the CL-PS6700 is empty. Use any of the GPIO ports instead of RUN.

9.6 Clocks

When the CL-PS7111 is operating at 18 MHz, EXPCLK is driven out as the clock for the CL-PS6700. The clock can be disabled through the Memory Configuration register. If the CL-PS7111 is operating at 13 MHz, an external oscillator provides the clock on EXPCLK to the CL-PS6700. Since the 13-MHz clock can be disabled (through the RUN/CLKEN output during standby mode), ensure that there are no pending transactions.

Appendix A

Source Address Locator

Data sheets and application notes can be downloaded from your board supplier web site.

Abracon Corporation®: www.abracon.com	Supplier of crystals and oscillators
Accelerated Technology, Inc.®: www.atinucleus.com	Supplier of the Nucleus O/S
Alps Electric®: www.alps.com	Supplier of LCD panels and keyboards
AMD®: www.amd.com	Supplier of flash memory
AMP®: www.amp.com	Supplier of connectors
ARM Ltd.®: www.arm.com	Supplier of CPU support tools
Cygnus®: www.cygnus.com	Supplier of development software tools
Maxim®: www.maxim-ic.com	Supplier of power ICs
Molex®: www.molex.com	Supplier of connectors
Oki America, Inc.®: www.oki.com	Supplier of codecs
Temic®: www.temic.com	Supplier of Power MOSFET

Appendix B

Bill of Materials

The bill of materials is in the DEB7111.BOM file.

CL-PS7111 EVAL Board
DEB7111.SCH
Revision: B
Bill of Materials

Revised: January 8, 1997

January 14, 1997

Item	Quantity	Reference	Part
1	1	CH1	100 pF
2	26	C1	10 nF
		C10	10 nF
		C15	10 nF
		C16	10 nF
		C17	10 nF
		C19	10 nF
		C20	10 nF
		C21	10 nF
		C29	10 nF
		C31	10 nF
		C32	10 nF
		C35	10 nF
		C40	10 nF
		C42	10 nF
		C47	10 nF
		C49	10 nF
		C58	10 nF
		C62	10 nF
		C64	10 nF
		C65	10 nF
		C67	10 nF
		C69	10 nF
		C70	10 nF
		C83	10 nF
		C84	10 nF
		C96	10 nF

CL-PS7111 EVAL Board
 DEB7111.SCH
 Revision: B
 Bill of Materials (cont.)

Revised: January 8, 1997

January 14, 1997

Item	Quantity	Reference	Part
3	4	C2	2.2 μ F
		C3	2.2 μ F
		C61	2.2 μ F
		C82	2.2 μ F
4	25	C4	100 nF
		C5	100 nF
		C6	100 nF
		C7	100 nF
		C8	100 nF
		C9	100 nF
		C11	100 nF
		C12	100 nF
		C13	100 nF
		C14	100 nF
		C22	100 nF
		C23	100 nF
		C24	100 nF
		C30	100 nF
		C38	100 nF
		C39	100 nF
		C43	100 nF
		C44	100 nF
		C45	100 nF
		C48	100 nF
5	4	C63	100 nF
		C66	100 nF
		C68	100 nF
		C73	100 nF
6	13	C79	100 nF
		C18	47 pF
		C60	47 pF
		C93	47 pF
		C94	47 pF
		C25	1 nF
		C26	1 nF
		C27	1 nF

CL-PS7111 EVAL Board
 DEB7111.SCH
 Revision: B
 Bill of Materials (cont.)

Revised: January 8, 1997

January 14, 1997

Item	Quantity	Reference	Part
6 (cont.)		C28	1 nF
		C36	1 nF
		C50	1 nF
		C51	1 nF
		C52	1 nF
		C53	1 nF
		C54	1 nF
		C55	1 nF
		C56	1 nF
		C57	1 nF
7	1	C33	0.22 F
8	2	C34	1 μ F
		C87	1 μ F
9	4	C37	47 μ F
		C41	47 μ F
		C74	47 μ F
		C75	47 μ F
		C59	15 pF
10	1	C72	0.33 μ F
		C71	0.33 μ F
11	2	C76	33 μ F
		C77	33 μ F
		C81	33 μ F
		C80	4.7 μ F
12	3	C78	4.7 μ F
		C86	0.47 μ F
13	2	C85	0.47 μ F
		C88	0.1 μ F
14	2	C89	0.1 μ F
		C90	3.3 μ F
15	2	C91	3.3 μ F
		C92	1 μ F/16 V
16	1	C97	4.7 μ F/35 V
		C98	4.7 μ F/35 V
		C99	4.7 μ F/35 V
		C100	4.7 μ F/35 V
17	4		
18	1		

CL-PS7111 EVAL Board
 DEB7111.SCH
 Revision: B
 Bill of Materials (cont.)

Revised: January 8, 1997

January 14, 1997

Item	Quantity	Reference	Part
19	1	D2	MAX809R
20	4	D3	BAV70
		D4	BAV70
		D5	BAV70
		D7	BAV70
21	5	D6	1N5817
		D10	1N5817
		D13	1N5817
		D14	1N5817
		D15	1N5817
22	2	D8	1N4148
		D9	1N4148
23	1	D11	14 V
24	1	D12	1N5818
25	1	D16	BAT54C
26	2	J1	ZIF17
		J15	ZIF17
27	1	J2	ZIF11
28	1	J3	HDR2
29	1	J4	HDR25
30	8	W3	JMP2
		J5	JMP2
		W7	JMP2
		J7	JMP2
		W8	JMP2
		W11	JMP2
		W12	JMP2
		W15	JMP2
31	1	J6	PHONOSW
32	1	J8	TFDS3000
33	1	J9	CONAC
34	1	J10	HDR25X2
35	1	J11	PCMCIA68
36	2	J12	AMP557908-1
		J25	AMP557908-1
37	1	J13	SM30

CL-PS7111 EVAL Board
 DEB7111.SCH
 Revision: B
 Bill of Materials (cont.)

Revised: January 8, 1997

January 14, 1997

Item	Quantity	Reference	Part
38	1	J14	HDR3
39	1	J16	4HEADER
40	1	J17	JEIDA88
41	1	J18	HDR2x2
42	5	J19	HPPOD20
		J20	HPPOD20
		J21	HPPOD20
		J22	HPPOD20
		J23	HPPOD20
43	1	J24	HDR17
44	1	LS1	SPEAKER
45	1	LS2	BUZZER
46	4	L1	FERRITE
		L4	FERRITE
		L5	FERRITE
		L10	FERRITE
47	3	L2	47 μ H
		L3	47 μ H
		L7	47 μ H
48	2	L8	22 μ H
		L6	22 μ H
49	1	L9	15 μ H
50	5	R1	1 k Ω
		R36	1 k Ω
		R96	1 k Ω
		R97	1 k Ω
		R98	1 k Ω
51	1	R2	5 Ω
52	24	R3	100 k Ω
		R9	100 k Ω
		R11	100 k Ω
		R12	100 k Ω
		R13	100 k Ω
		R14	100 k Ω
		R16	100 k Ω
		R25	100 k Ω

CL-PS7111 EVAL Board
 DEB7111.SCH
 Revision: B
 Bill of Materials (cont.)

Revised: January 8, 1997

January 14, 1997

Item	Quantity	Reference	Part
		R34	100 k Ω
		R35	100 k Ω
		R39	100 k Ω
		R41	100 k Ω
52 (cont.)		R48	100 k Ω
		R50	100 k Ω
		R51	100 k Ω
		R52	100 k Ω
		R53	100 k Ω
		R56	100 k Ω
		R59	100 k Ω
		R60	100 k Ω
		R62	100 k Ω
		R67	100 k Ω
		R68	100 k Ω
		R71	100 k Ω
53	16	R4	10 k Ω
		R7	10 k Ω
		R21	10 k Ω
		R24	10 k Ω
		R27	10 k Ω
		R29	10 k Ω
		R43	10 k Ω
		R44	10 k Ω
		R45	10 k Ω
		R69	10 k Ω
		R73	10 k Ω
		R75	10 k Ω
		R89	10 k Ω
		R90	10 k Ω
		R91	10 k Ω
		R95	10 k Ω
54	2	R57	47 k Ω
		R6	47 k Ω
55	4	R8	10 Ω
		R33	10 Ω

CL-PS7111 EVAL Board
 DEB7111.SCH
 Revision: B
 Bill of Materials (cont.)

Revised: January 8, 1997

January 14, 1997

Item	Quantity	Reference	Part
		R87	10 Ω
		R92	10 Ω
56	1	R10	140 k Ω
	1	R70	120 k Ω
57	4	R15	2.2 k Ω
		R28	2.2 k Ω
		R30	2.2 k Ω
		R31	2.2 k Ω
58	2	R17	144 Ω
		R19	144 Ω
59	1	R18	18 k Ω
60	1	R20	33 Ω
61	2	R22	15 k Ω
		R72	15 k Ω
62	1	R23	7.5 k Ω
63	5	R26	390 k Ω
		R32	390 k Ω
		R40	390 k Ω
		R42	390 k Ω
		R49	390 k Ω
64	4	R37	100 Ω
		R61	100 Ω
		R74	100 Ω
		R94	100 Ω
65	1	R38	470 k Ω
66	1	R47	500 k Ω
67	1	R54	270 k Ω
68	1	R55	22 k Ω
69	1	R58	240 k Ω
70	1	R63	200 k Ω
71	1	R64	392 k Ω
72	1	R65	806 k Ω
73	7	R76	100 k Ω \times 8
		R77	100 k Ω \times 8
		R78	100 k Ω \times 8
		R80	100 k Ω \times 8

CL-PS7111 EVAL Board
 DEB7111.SCH
 Revision: B
 Bill of Materials (cont.)

Revised: January 8, 1997

January 14, 1997

Item	Quantity	Reference	Part
		R81	100 k Ω \times 8
		R82	100 k Ω \times 8
		R83	100 k Ω \times 8
74	1	R84	0.1 Ω
75	1	R85	0.05 Ω
76	1	R93	150 Ω
77	2	R99	9 k Ω
		R105	9 k Ω
78	1	R104	4.7 k Ω
79	2	S2	SWSPST
		S1	SWSPST
80	51	TP1	NTP
81	4	TR1	FMMT4124
		TR2	FMMT4124
		TR3	FMMT4124
		TR4	FMMT4124
82	1	TR5	FMMT4124
83	1	U1	MAX756CSA
84	1	U2	HM51W16160ALTT-7
85	2	U5	29LV800BE
		U11	29LV800BE
86	1	U8	MSM7702-01MS
87	1	U9	MAX148BCAP
88	1	U12	MSC1192MS-K
89	1	U13	LM339MX
90	2	U14	29LV800BF
		U18	29LV800BF
91	2	U19	CL-PS7111
		U31	CL-PS7111
92	1	U20	MAX3212CAI
93	1	U21	SI4412DY
94	1	U22	SI4431DY
95	1	U23	MAX1651CSA
96	1	U24	MAX608ESA
97	1	U26	SI6426DQ
98	1	U27	CL-PS6700

CL-PS7111 EVAL Board
DEB7111.SCH
Revision: B
Bill of Materials (cont.)

Revised: January 8, 1997

January 14, 1997

Item	Quantity	Reference	Part
99	1	U28	SI9712DY
100	1	U29	13 MHz
101	1	U30	LM324
102	4	U32	AT29LV040
		U33	AT29LV040
		U34	AT29LV040
		U35	AT29LV040
103	4	W1	JMP3
		W2	JMP3
		W4	JMP3
		W6	JMP3
104	2	X1	3.6864 MHz
		X6	3.6864 MHz
105	2	X2	32.768 kHz
		X5	32.768 kHz

Appendix C

Schematics

Please contact Cirrus Logic for the latest CL-PS7111 schematic diagrams.

Notes



Direct Sales Offices

Domestic

N. CALIFORNIA

Fremont
TEL: 510/623-8300
FAX: 510/252-6020

S. CALIFORNIA

Westlake Village
TEL: 805/371-5860
FAX: 805/371-5861

NORTHWESTERN AREA

Portland, OR
TEL: 503/620-5547
FAX: 503/620-5665

SOUTH CENTRAL AREA

Austin, TX
TEL: 512/255-0080
FAX: 512/255-0733

Houston, TX
TEL: 281/257-2525
FAX: 281/257-2555

NORTHEASTERN AREA

Andover, MA
TEL: 978/794-9992
FAX: 978/794-9998

SOUTHEASTERN AREA

Raleigh, NC
TEL: 919/859-5210
FAX: 919/859-5334

Boca Raton, FL
TEL: 561/395-1613
FAX: 561/395-1373

International

CHINA

Beijing
TEL: 86/10-6428-0783
FAX: 86/10-6428-0786

FRANCE

Paris
TEL: 33/1-48-12-2812
FAX: 33/1-48-12-2810

GERMANY

Herrsching
TEL: 49/81-52-92460
FAX: 49/81-52-924699

HONG KONG

Tsimshatsui
TEL: 852/2376-0801
FAX: 852/2375-1202

JAPAN

Tokyo
TEL: 81/3-3340-9111
FAX: 81/3-3340-9120

KOREA

Seoul
TEL: 82/2-565-8561
FAX: 82/2-565-8565

SINGAPORE

TEL: 65/743-4111
FAX: 65/742-4111

TAIWAN

Taipei
TEL: 886/2-2718-4533
FAX: 886/2-2718-4526

UNITED KINGDOM

London, England
TEL: 44/01628-472211
FAX: 44/01628-486114

High-Value Systems in Silicon

Cirrus Logic is a premier supplier of advanced integrated circuits that combine mixed-signal processing, precision analog techniques, embedded processors, and application-specific algorithms into system-on-a-chip solutions for existing and emerging growth markets. Enhanced by strong systems expertise in selected markets, the company's products add high value to major brands worldwide in magnetic and optical storage, networking communications, consumer/professional audio, video, and imaging, and ultra-precision data acquisition.

Cirrus Logic's manufacturing strategy ensures maximum product quality and availability, as well as access to world-class processing technologies through joint ventures with IBM® and Lucent Technologies®.

Contact one of our systems and applications specialists to see how your company can benefit from the high value Cirrus Logic adds to its customers' products.

Copyright © 1997 Cirrus Logic, Inc. All rights reserved.

Cirrus Logic, Inc. has made best efforts to ensure that the information contained in this document is accurate and reliable. However, the information is subject to change without notice. No responsibility is assumed by Cirrus Logic, Inc. for the use of this information, nor for infringements of patents or other rights of third parties. This document is the property of Cirrus Logic, Inc. and implies no license under patents, copyrights, or trade secrets. Cirrus Logic, and Crystal are trademarks of Cirrus Logic, Inc., which may be registered in some jurisdictions. Other trademarks in this document belong to their respective companies. CRUS and Cirrus Logic International, Ltd. are trade names of Cirrus Logic, Inc.



LittleDiode supplies new, hard to find or obsolete electronic components and semiconductors all over the world.

With over two million different components listed you are sure to find the part you need.

Feel free to visit us today at our online store:

LittleDiode.com

Looking forward to providing you with the best possible service.